

# Section IV: Landscape Design Guidelines

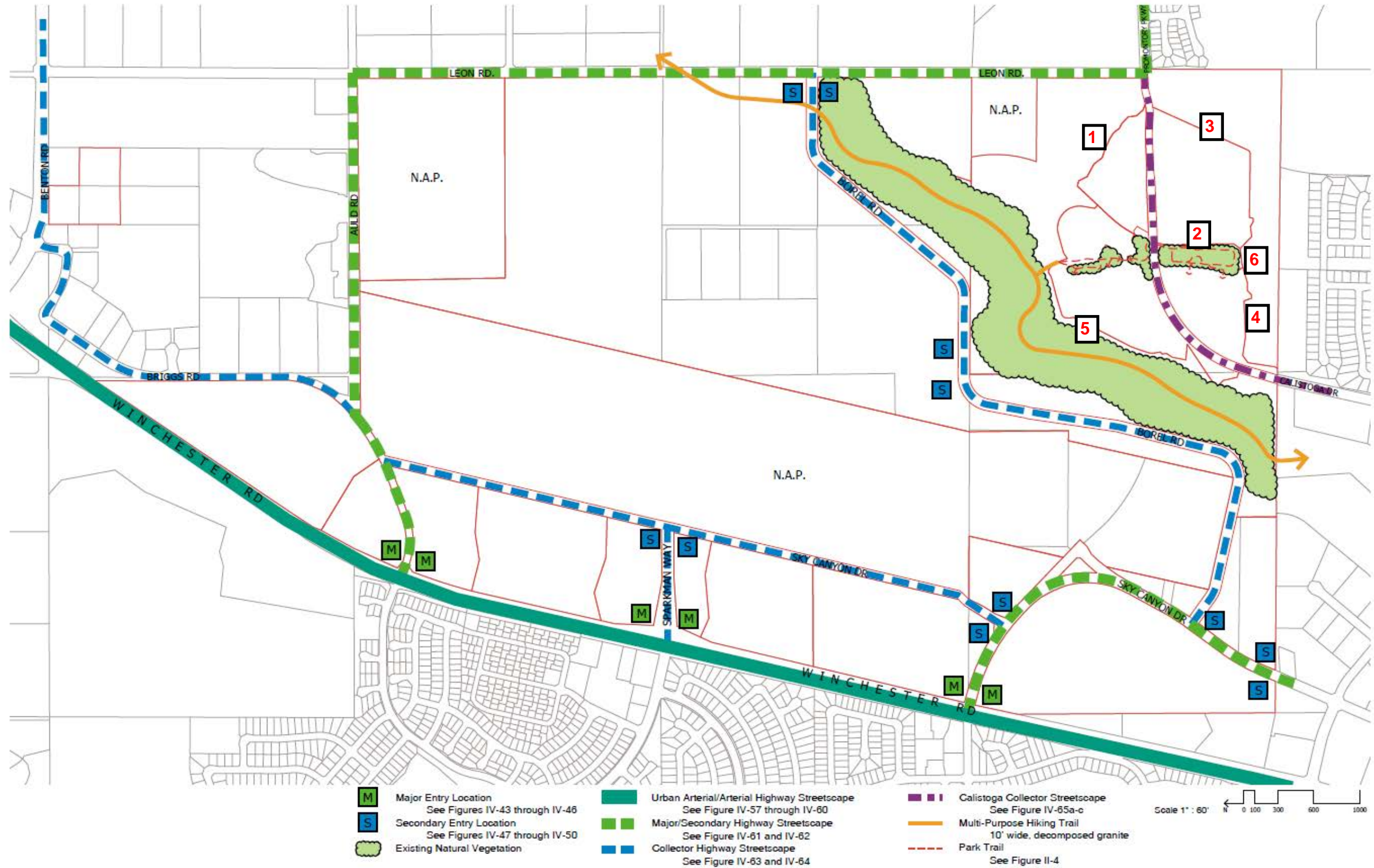

- 1** PA14 MEDIUM DENSITY RESIDENTIAL - PA 19 OPEN SPACE CONSERVATION EDGE CONDITION - SEE FIGURE IV-72
- 2** PA15 MEDIUM HIGH DENSITY RESIDENTIAL, PA16 MEDIUM DENSITY RESIDENTIAL - PA22 PARK/SECTION EDGE CONDITION - SEE FIGURE IV-73
- 3** PA15 MEDIUM HIGH DENSITY RESIDENTIAL - PA21 OPEN SPACE CONSERVATION EDGE CONDITION - SEE FIGURE IV-74

- 4** PA16 MEDIUM HIGH DENSITY RESIDENTIAL - PA21 OPEN SPACE CONSERVATION EDGE CONDITION - SEE FIGURE IV-75
- 5** PA17 MEDIUM DENSITY RESIDENTIAL - PA19 OPEN SPACE CONSERVATION EDGE CONDITION - SEE FIGURE IV-76
- 6** PA21 OPEN SPACE CONSERVATION - PA22 PARK SECTION/EDGE CONDITION - SEE FIGURE IV-77

**LANDSCAPE CONCEPT - FIGURE IV-40**



Section IV: Landscape Design Guidelines



OS-C Open Space - Conservation  
OS-R Open Space - Recreation  
Multi-Purpose Hiking Trail  
See Figure II-4

Scale 1" : 80'



**PLANTING CONCEPT LEGEND**

TREES				
SYM.	BOTANICAL NAME	COMMON NAME	SIZE	WULCOLS
<b>CALISTOGA DRIVE</b>				
	PINUS ELDERICA	AFGHAN PINE	24" BOX	
	PODOCARPUS GRACILIOR	FERN PINE	24" BOX	
<b>INTERIOR STREETS</b>				
	ARBUTUS UNEDO 'MARINA'	MARINA STRAWBERRY TREE	24" BOX	
	CINNAMOMUM CAMPHORA	CAMPHOR TREE	24" BOX	
	LAGERSTROMIA FAURIEI X INDICA	GRAPE MYRTLE	24" BOX	
	LOPHOSTEMON CONFERTUS	BRISBANE BOX	24" BOX	
	OLEA EUROPAEA	FRUITLESS OLIVE	24" BOX	
<b>PARKS</b>				
	LAGERSTROMIA FAURIEI X INDICA (STANDARD)	GRAPE MYRTLE	24" BOX	
	OLEA EUROPAEA	FRUITLESS OLIVE	24" BOX	
	PLATANUS RACEMOSA	CALIFORNIA SYCAMORE	24" BOX	
<b>PERIMETER SLOPES (outside brush management)</b>				
	QUERCUS AGRIFOLIA	COAST LIVE OAK	15 GAL.	
	PLATANUS RACEMOSA	CALIFORNIA SYCAMORE	15 GAL.	
<b>INTERIOR SLOPES</b>				
	LAGERSTROMIA FAURIEI X INDICA (MULTI-TRUNK)	GRAPE MYRTLE	24" BOX	
	PINUS ELDERICA	AFGHAN PINE	24" BOX	
	RHUS LANCEA	AFRICAN SUMAC	24" BOX	

SHRUBS (WATER QUALITY BASINS)				
SYM.	BOTANICAL NAME	COMMON NAME	SIZE	DETAIL
	CAREX DIVULSA	BERKELEY SEDGE	1 GAL.	
	CAREX FRAEGRACILIS	WESTERN MEADOW SEDGE	1 GAL.	
	MUHLENBERGIA CAPILLARIS	PINK MUHLY	1 GAL.	
<b>VINES - CALISTOGA DRIVE AND PARKS</b>				
SYM.	BOTANICAL NAME	COMMON NAME	SIZE	DETAIL
NS	JASMINUM POLYANTHUM	PINK JASMINE	15 GAL.	
	CLYSTOMA CALLESTES/ODES	LAVENDAR TRUMPET VINE	15 GAL.	
<b>TURF - ACTIVE USE AREAS OF PARKS</b>				
	MARATHON II		SOD	

**Section IV: Landscape Design Guidelines**

SHRUBS - CALISTOGA DRIVE AND PARKS				
SYM.	BOTANICAL NAME	COMMON NAME	SIZE	WULCOLS
<b>PARKWAY</b>				
	CAREX DIVULSA	BERKELEY SEDGE	1 GAL.	
<b>BACK OF WALK AND ADJACENT SLOPES</b>				
	ANNIGOZANTHOS SP.	KANGAROO PAN	5 GAL.	
	BACCHARIS PILULARIS 'TWIN PEAKS'	DWARF COYOTE BRUSH	1 GAL.	
	DIETES BICOLOR	FORTNIGHT LILY	1 GAL.	
	ECHIUM FASTUOSUM	ECHIUM	5 GAL.	
	LIGUSTRUM TEXANUM	TEXAS PRIVET	5 GAL.	
	MYOPORUM PARVIFOLIUM	PROSTRATE MYOPORUM	1 GAL.	
	RHAPHIOLEPIS I. 'CLARA'	WHITE INDIA HAWTHORN	5 GAL.	
	ROSA 'ICEBERG'	ICEBERG ROSE	5 GAL.	
	TRACHELOSPERMUM JASMONOIDES	STAR JASMINE	1 GAL.	
<b>SHRUBS (PERIMETER BRUSH MANAGEMENT SLOPES AND ADJACENT TO OPEN SPACE)</b>				
SYM.	BOTANICAL NAME	COMMON NAME	SIZE	DETAIL
	ACACIA REDOLENS 'DESERT CARPET'	DESERT CARPET	1 GAL.	
	BACCHARIS P. X CONSANGUINEA	CHAPARRAL BROOM	1 GAL.	
	HETEROMELES ARBUTIFOLIA	TOYON	1 GAL.	
	RHUS INTEGRIFOLIA	LEMONADE BERRY	1 GAL.	
	SALVIA SONOMENSIS	CREEPING SAGE	1 GAL.	





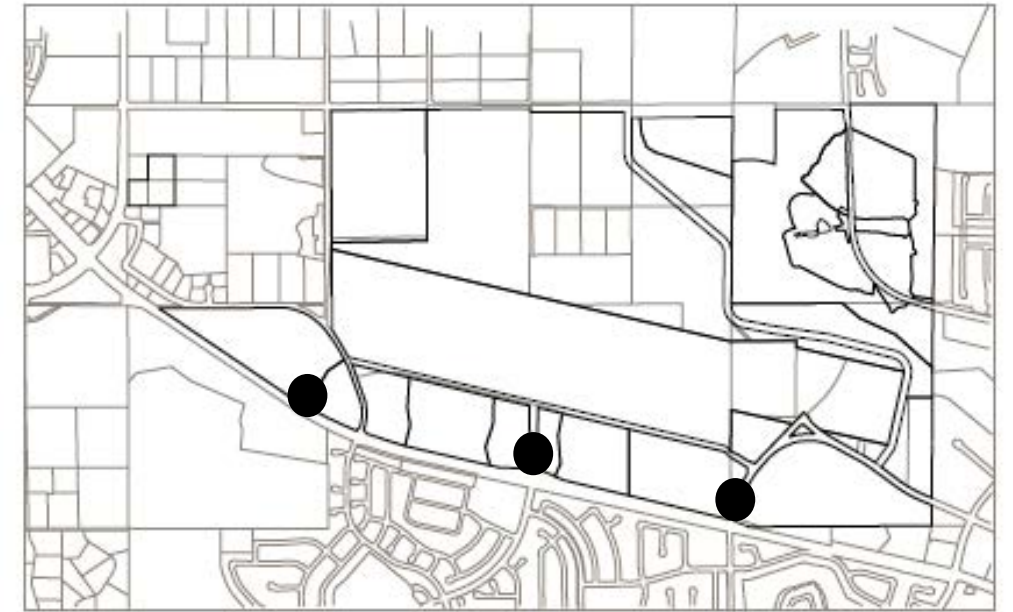
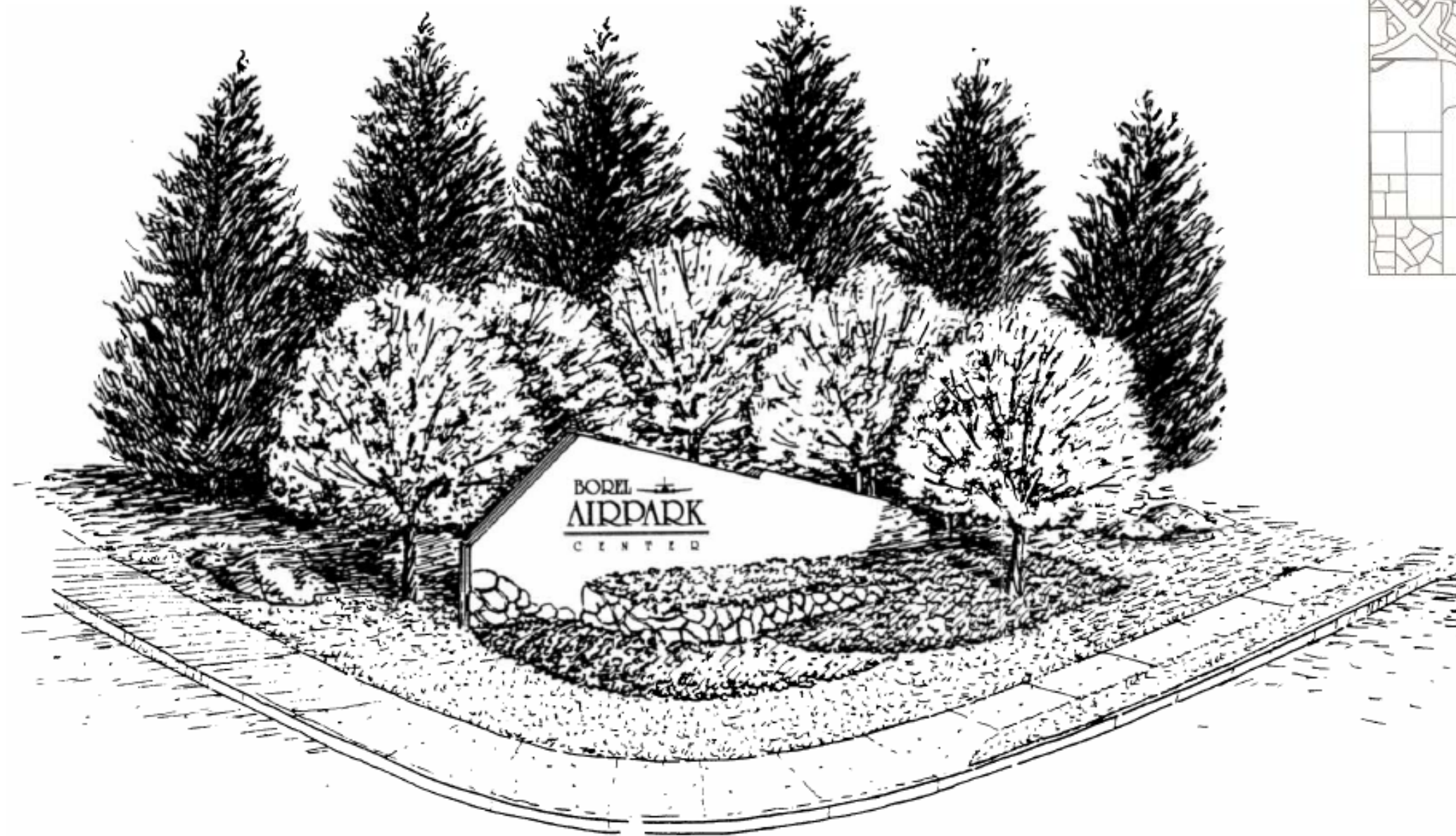

KEY MAP



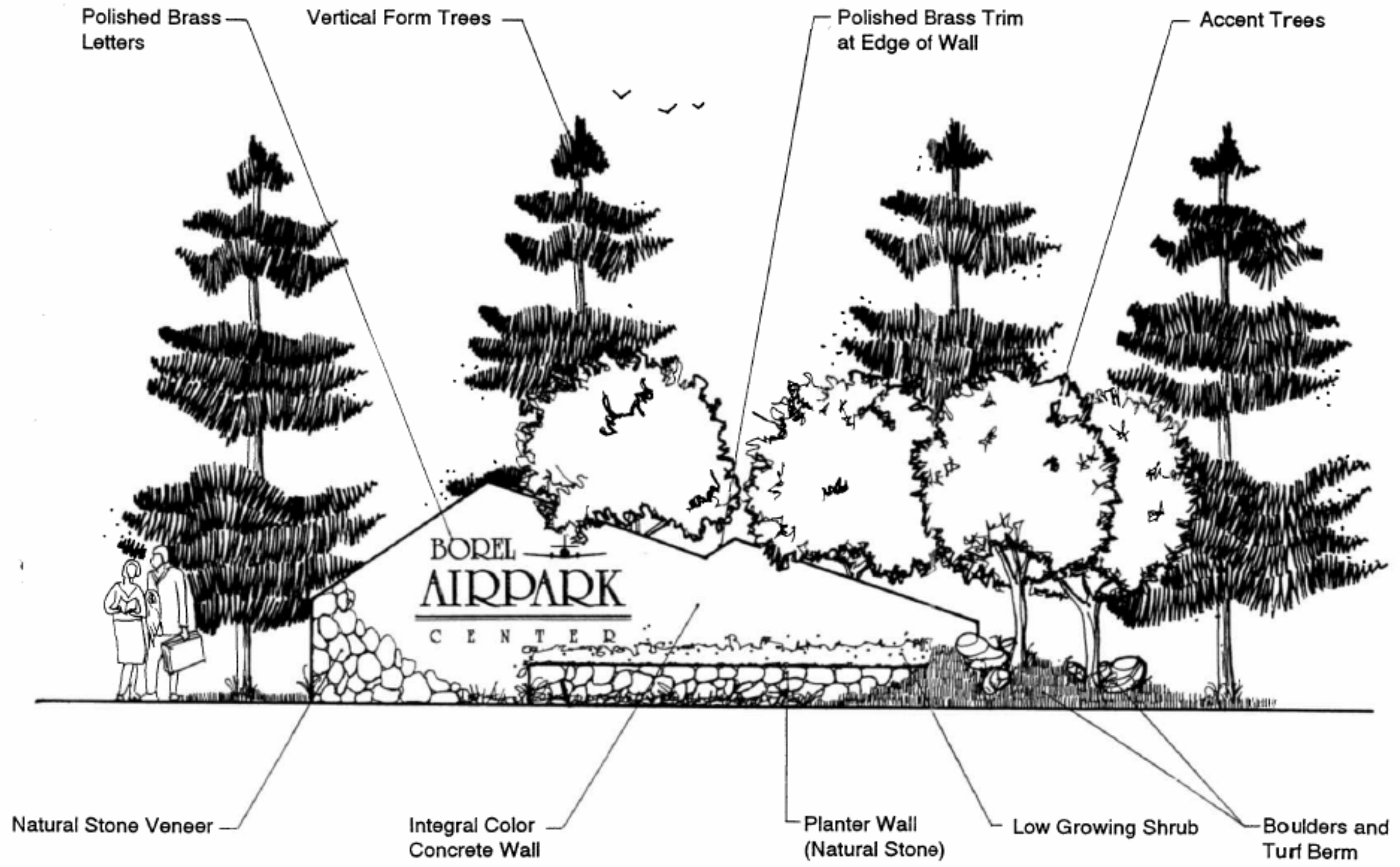

MAJOR ENTRY ELEVATION - FIGURE IV-44



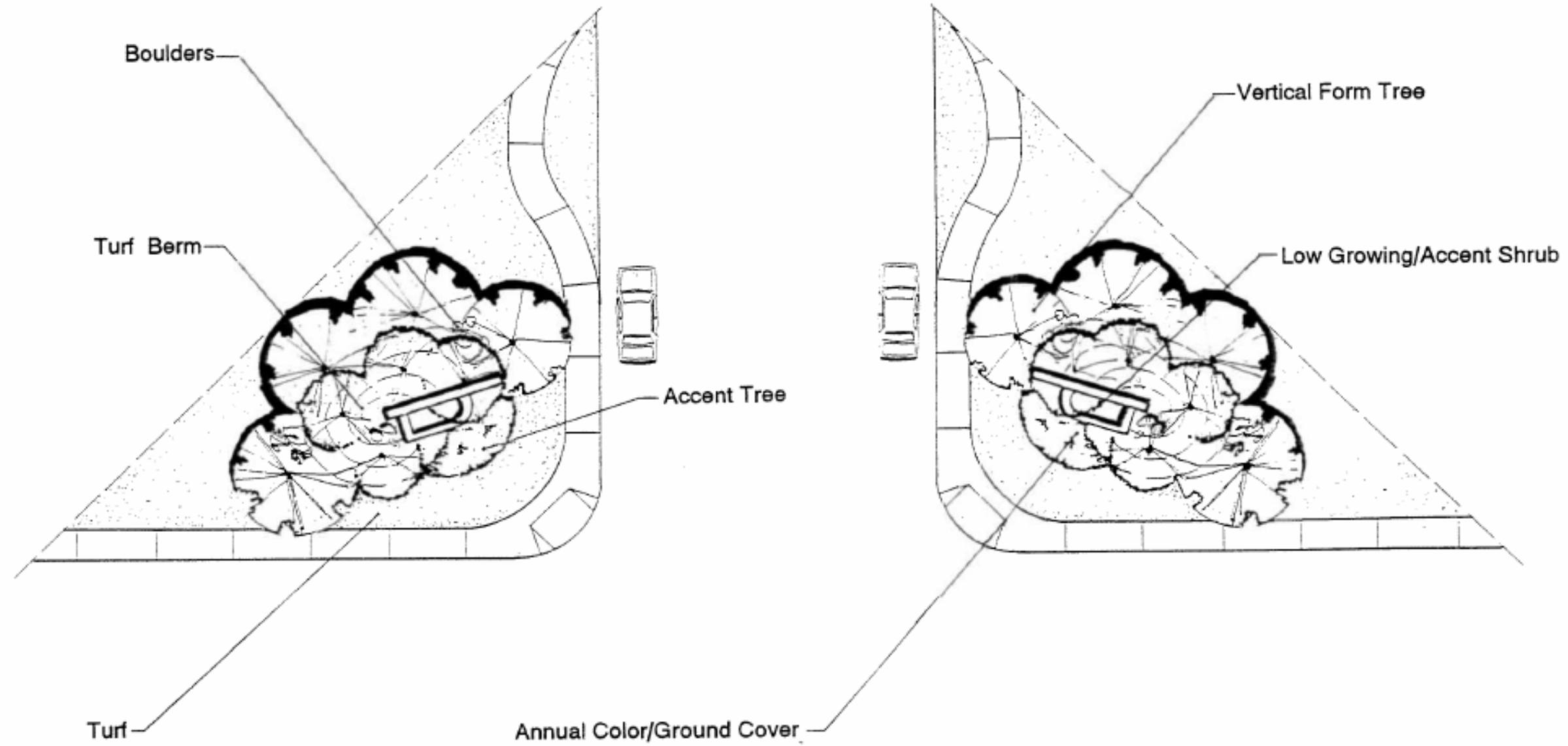



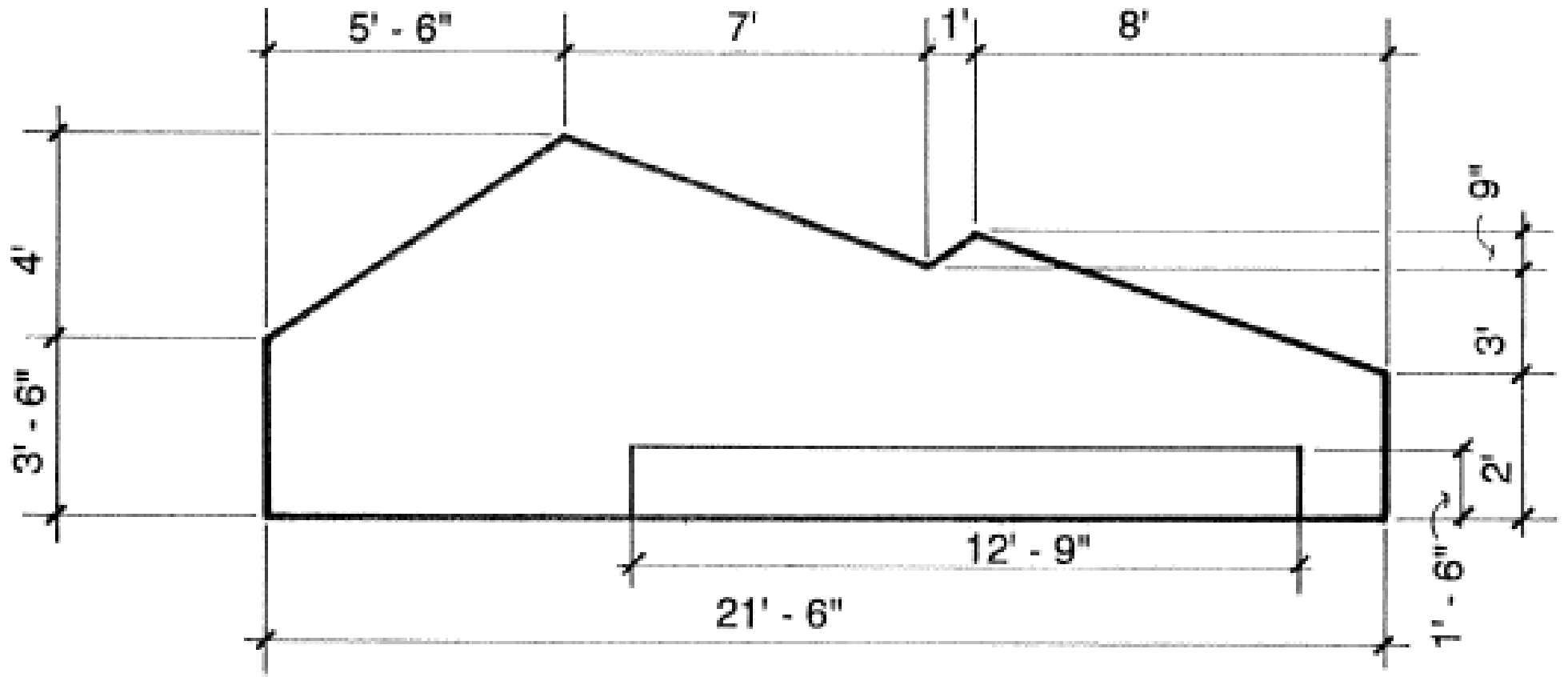



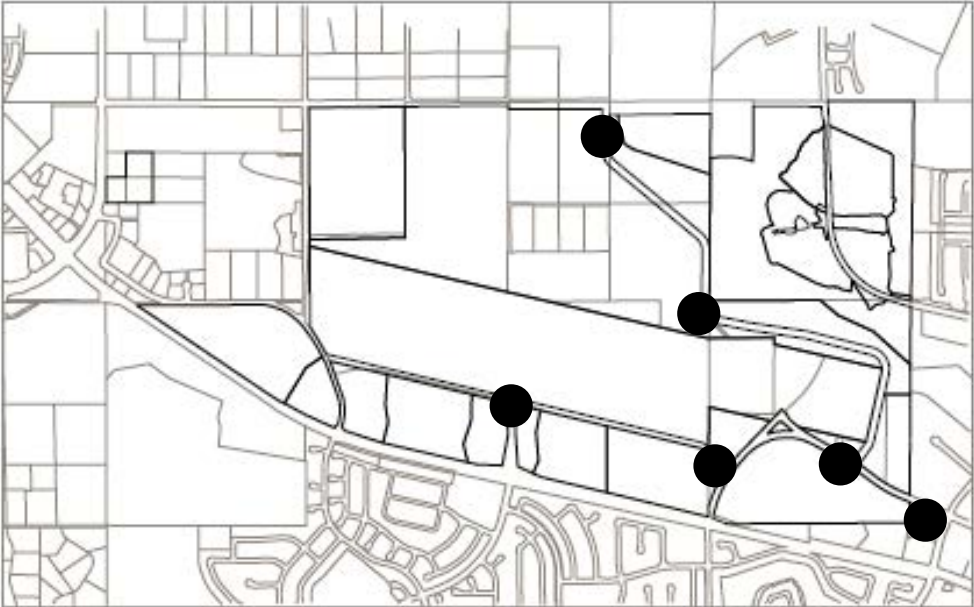

KEY MAP

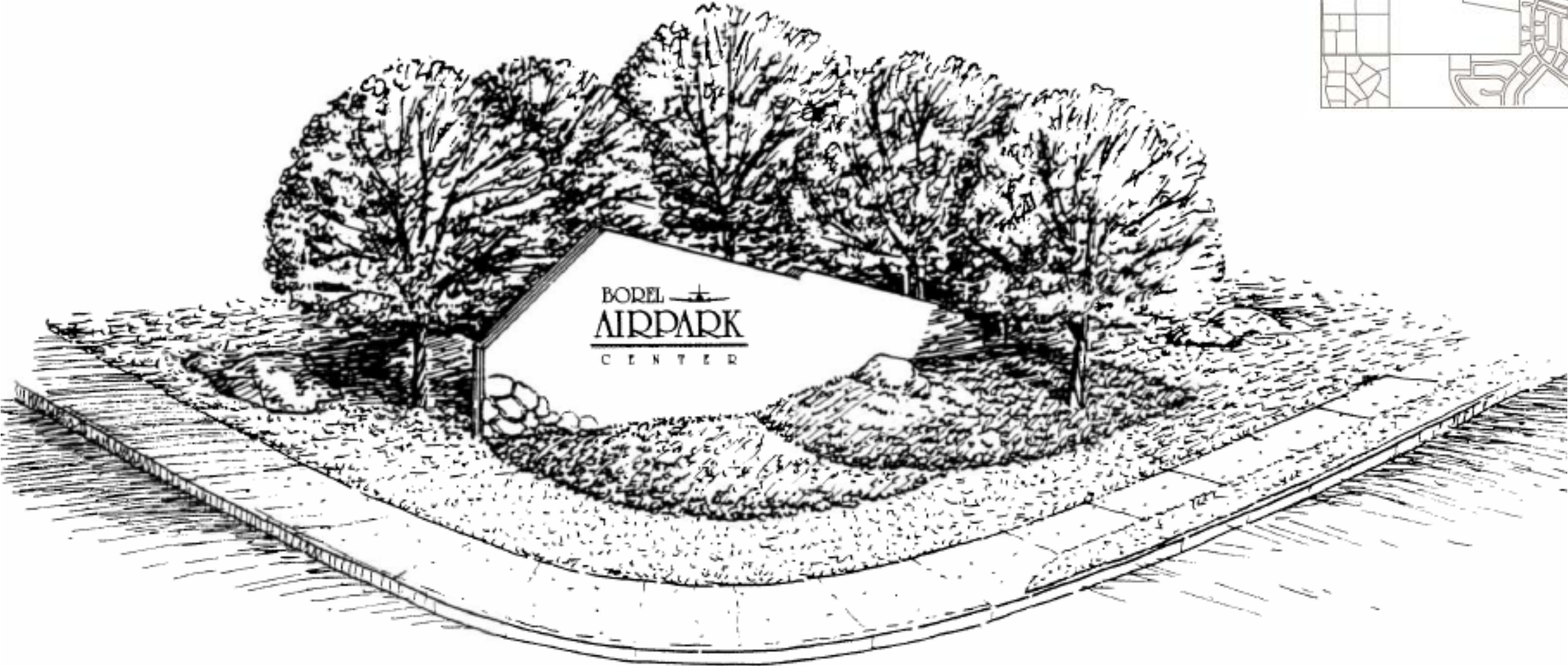



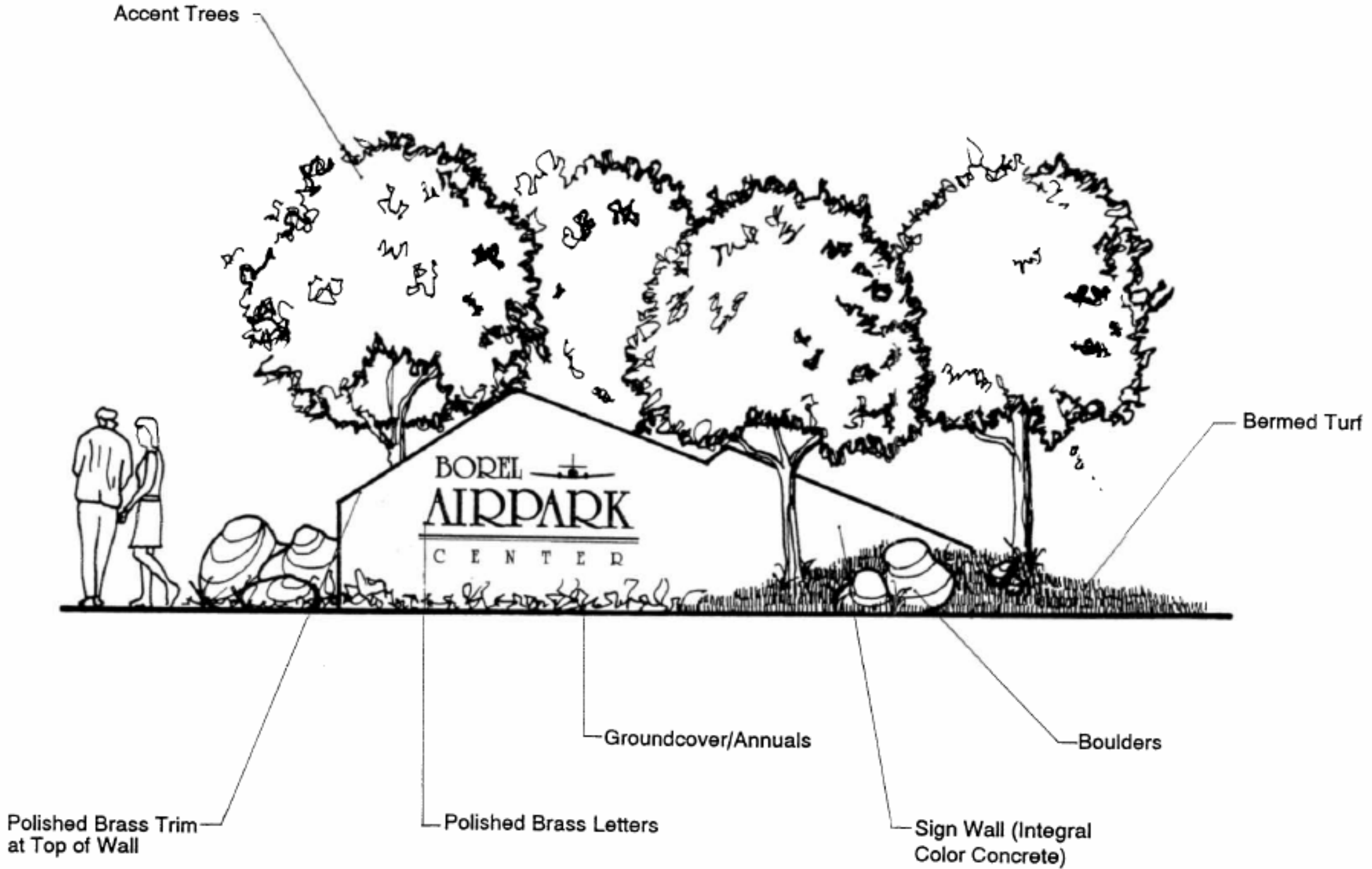

SECONDARY ENTRY ELEVATION - FIGURE IV-48



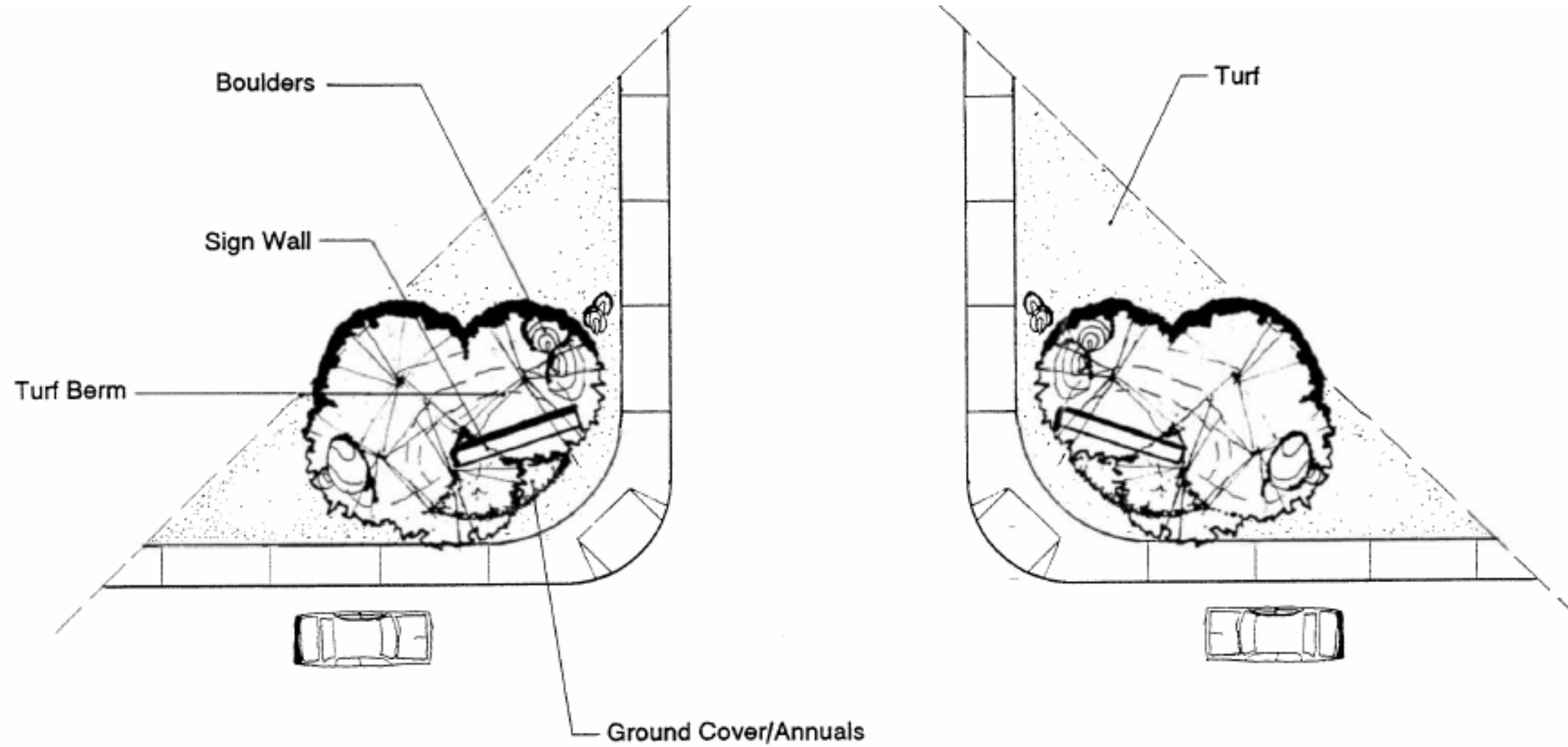

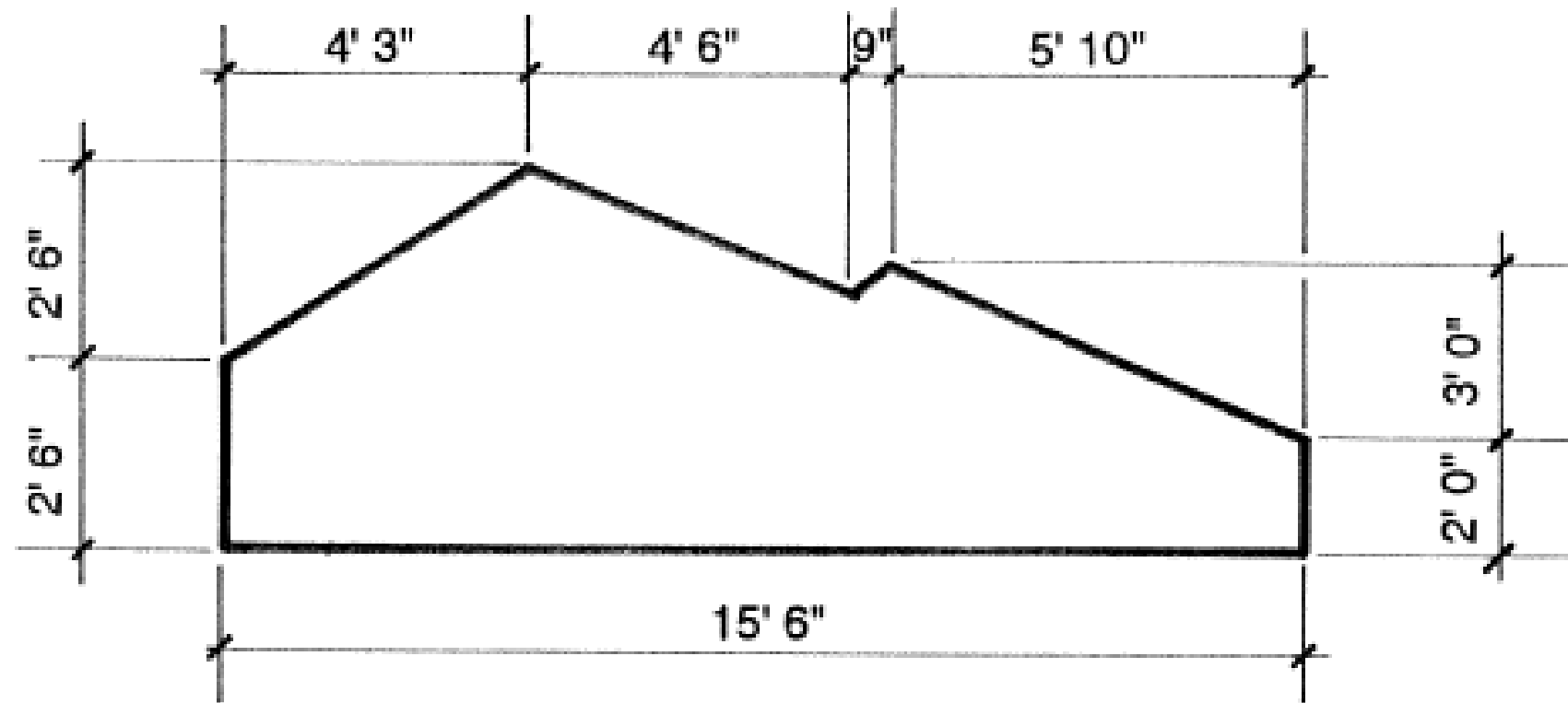



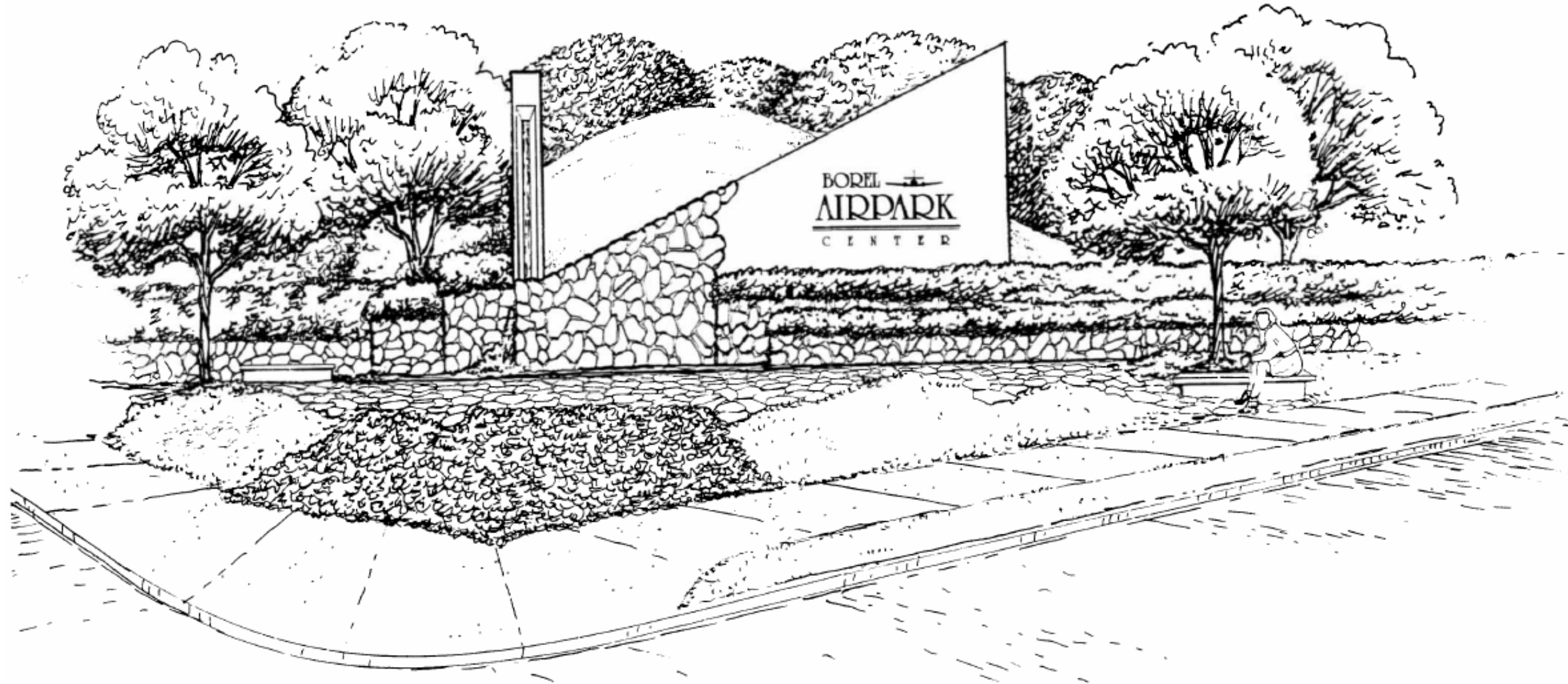

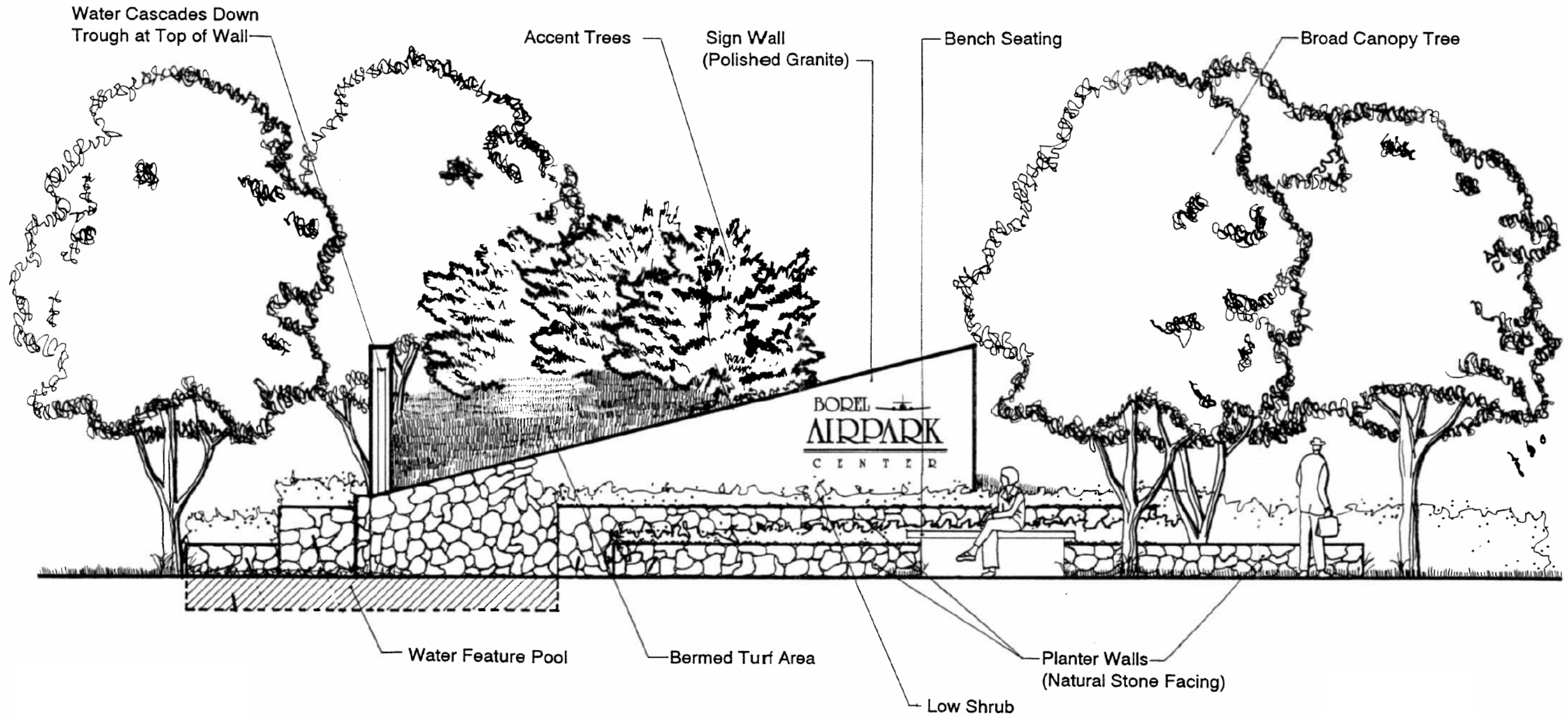



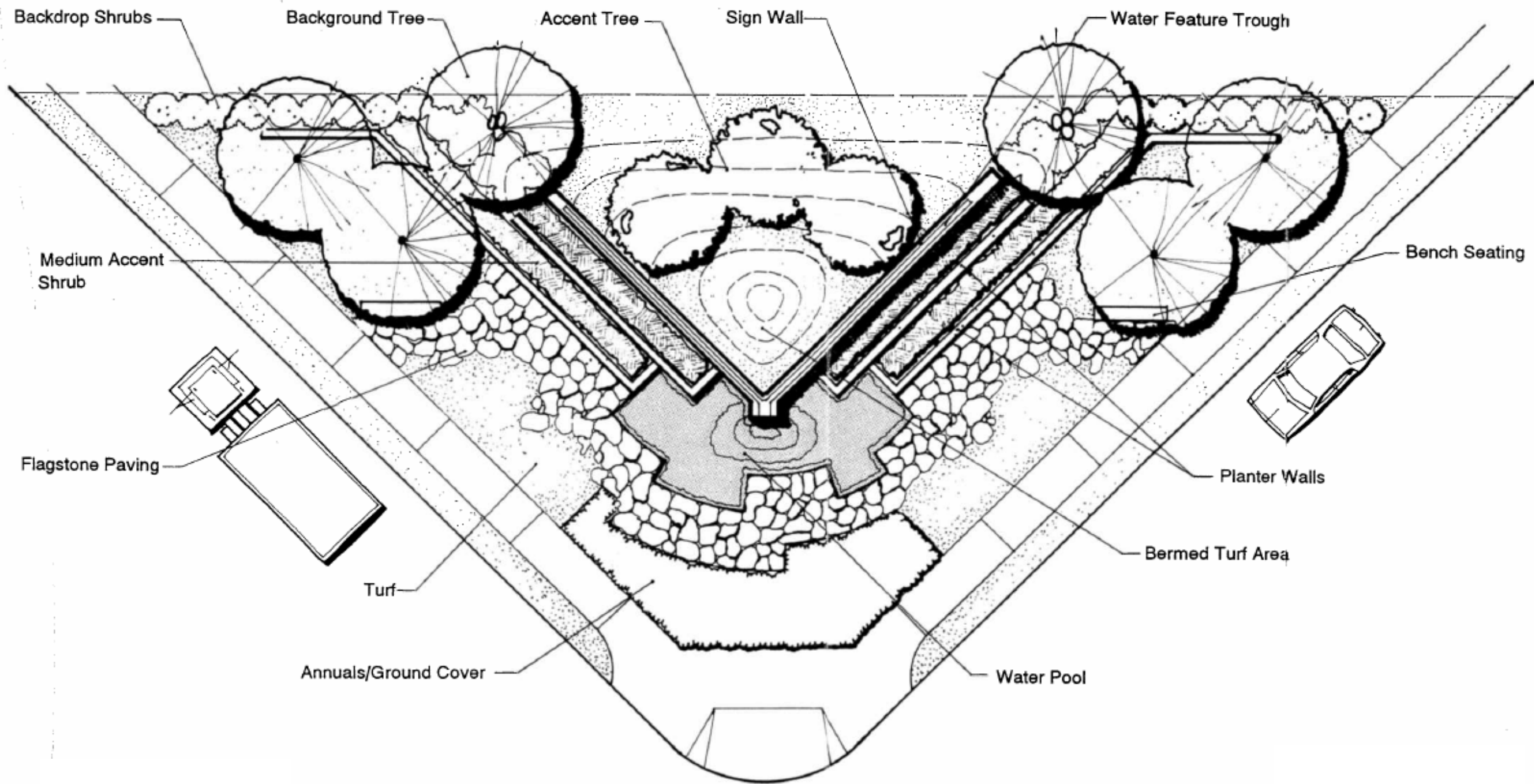

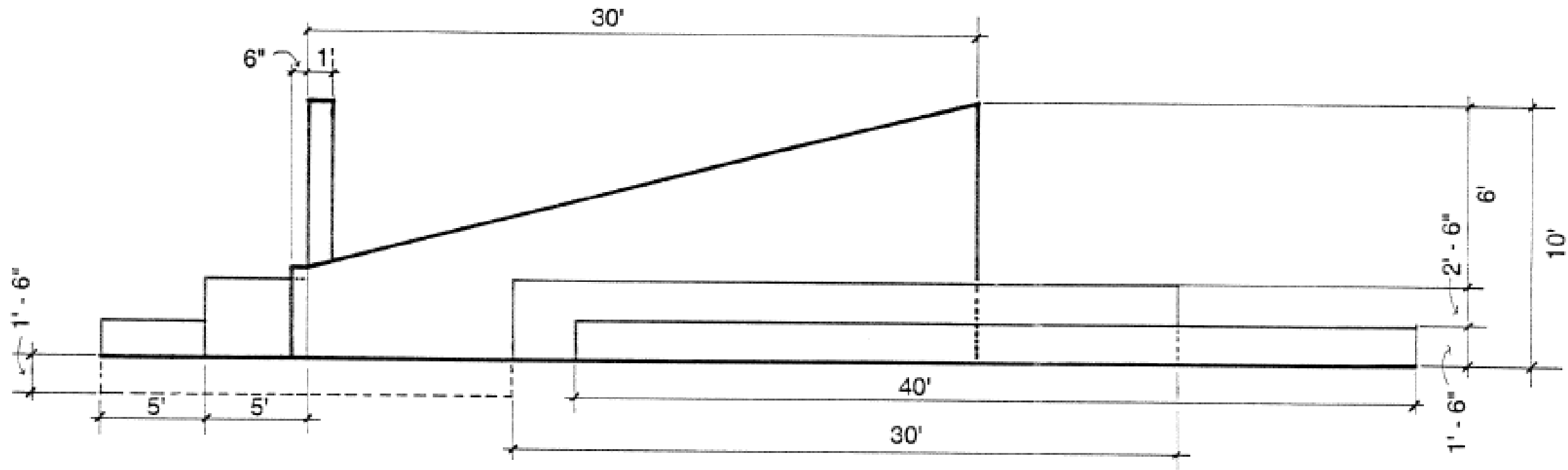



CALISTOGA DRIVE & STREETS 'K' & 'G' INTERSECTION

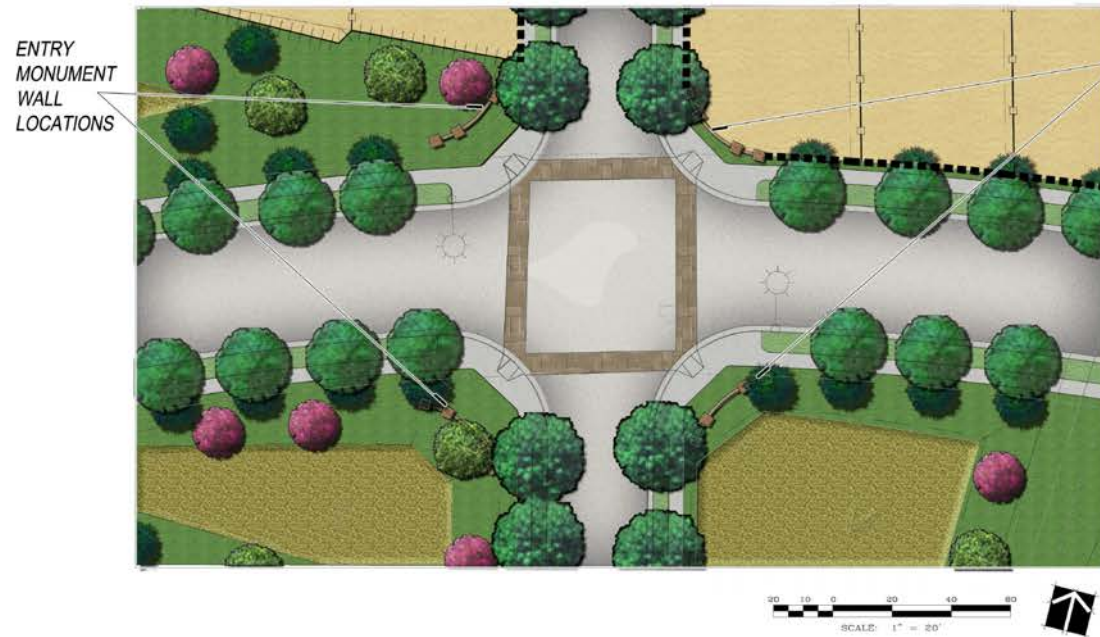

CALISTOGA DRIVE & STREETS 'D' & 'E' INTERSECTION

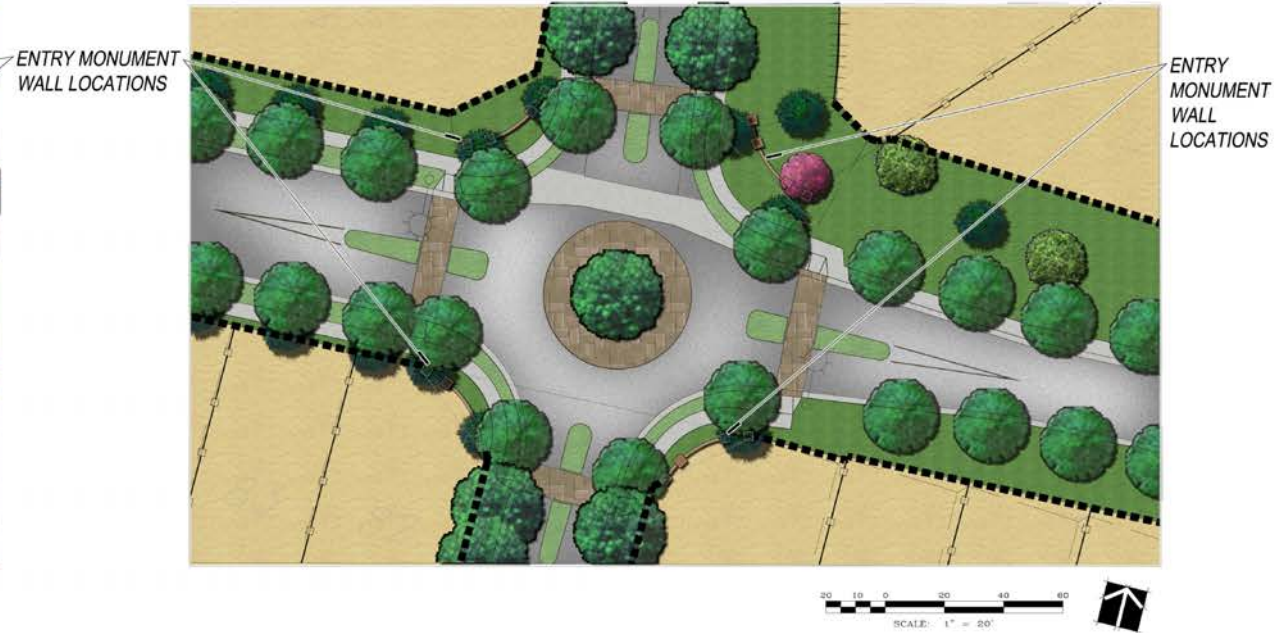



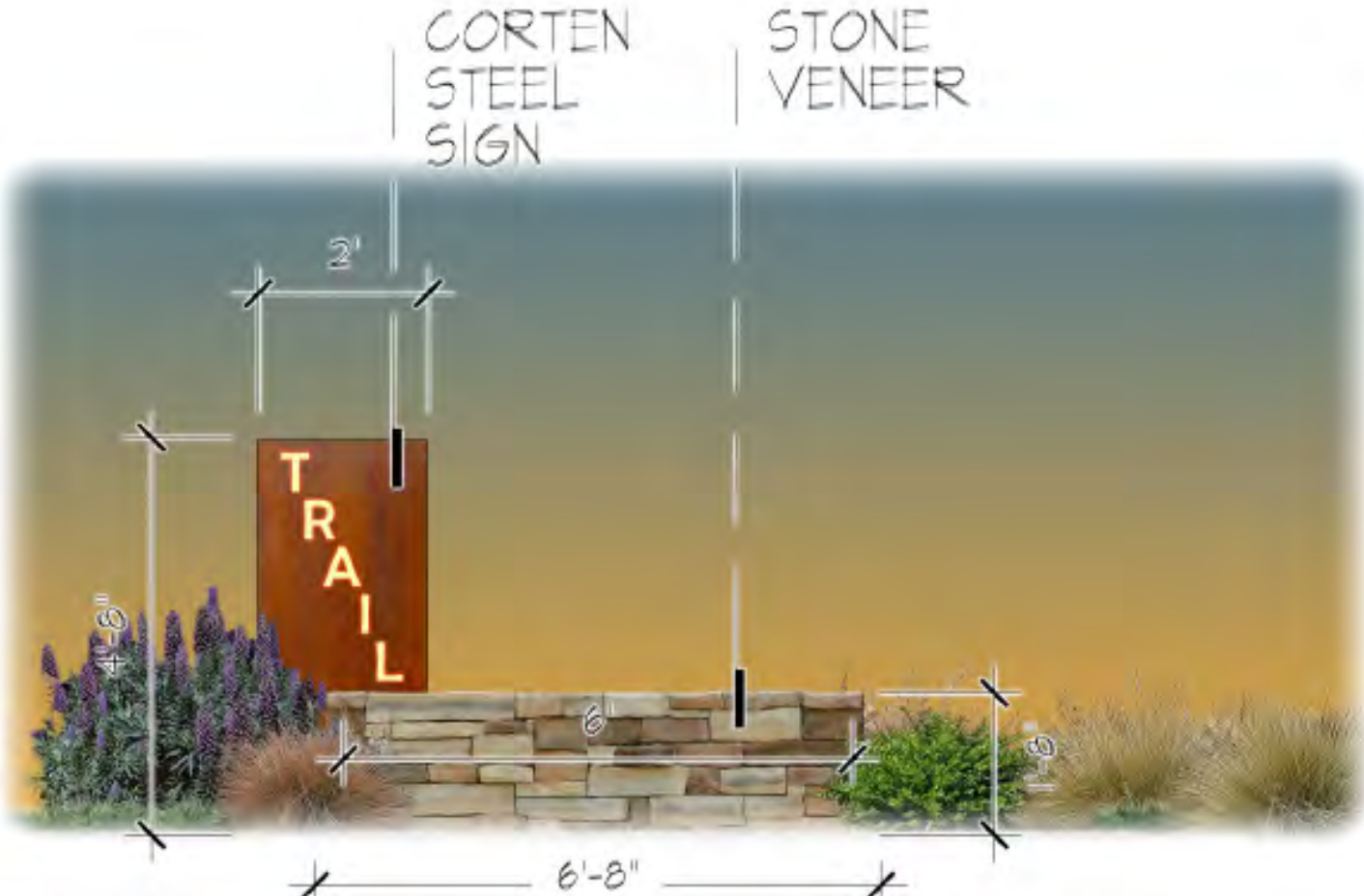
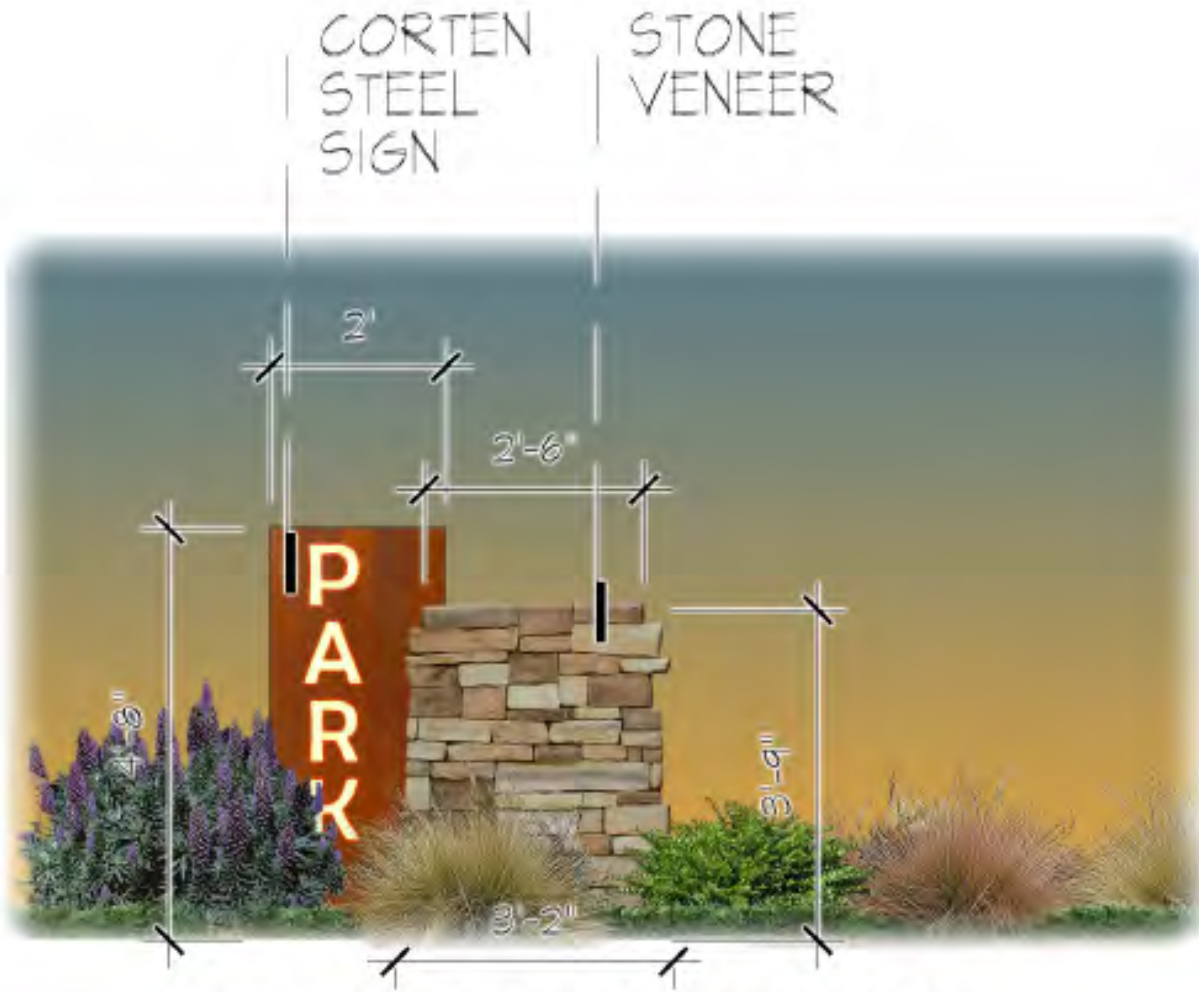

RESIDENTIAL PARK AND TRAIL MONUMENTATION - FIGURE IV-56



Section IV: Landscape Design Guidelines

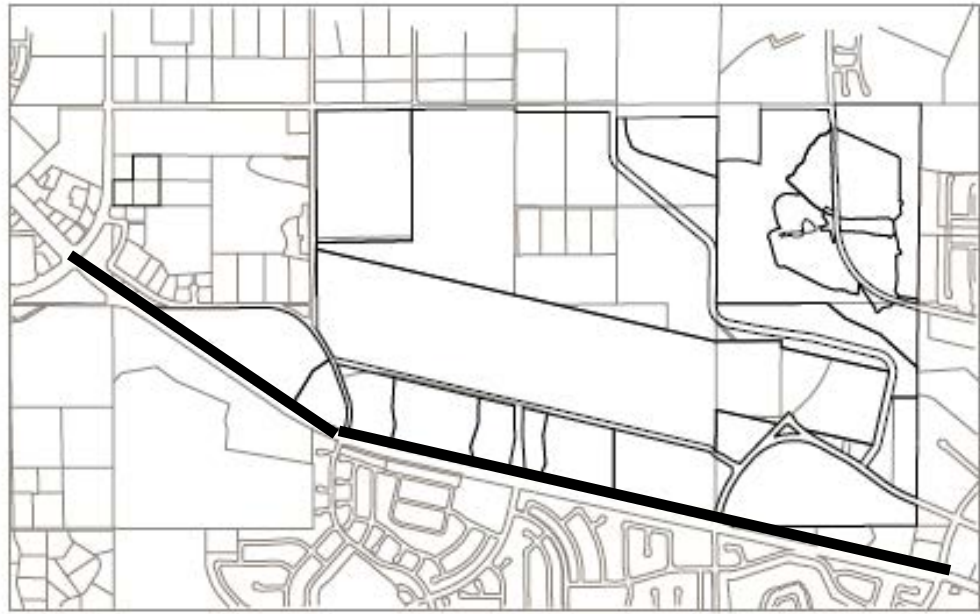
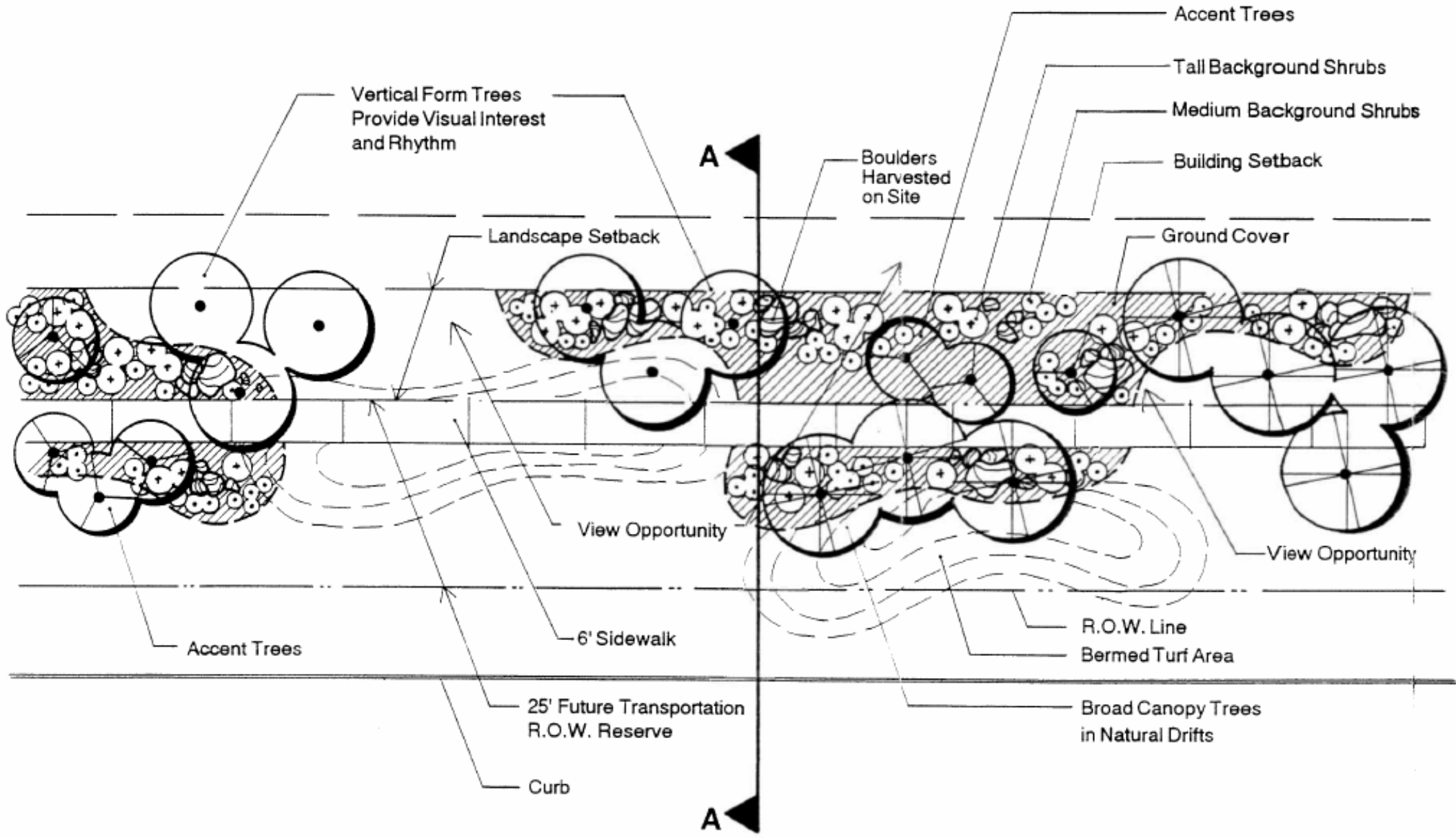

KEY MAP

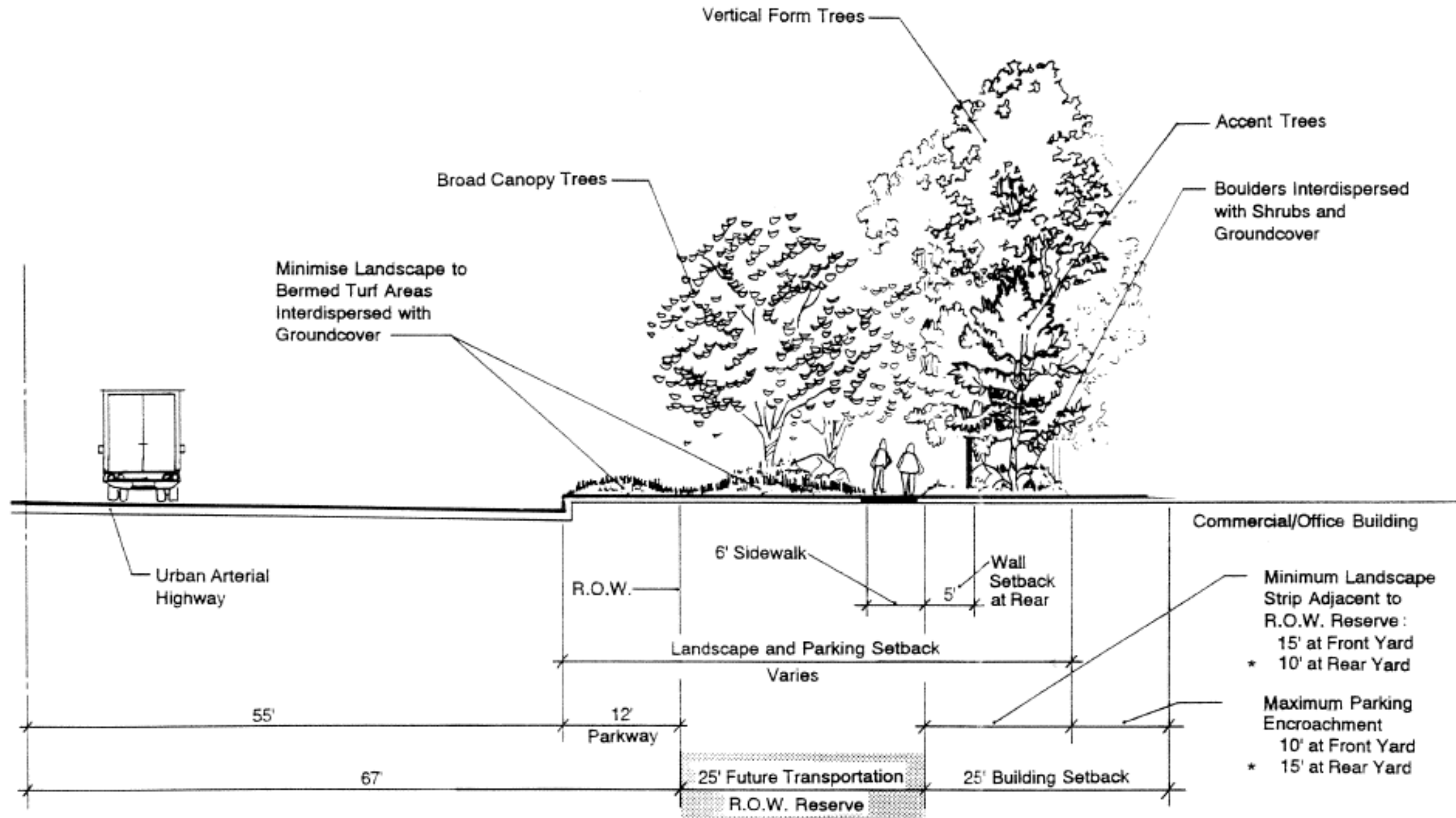



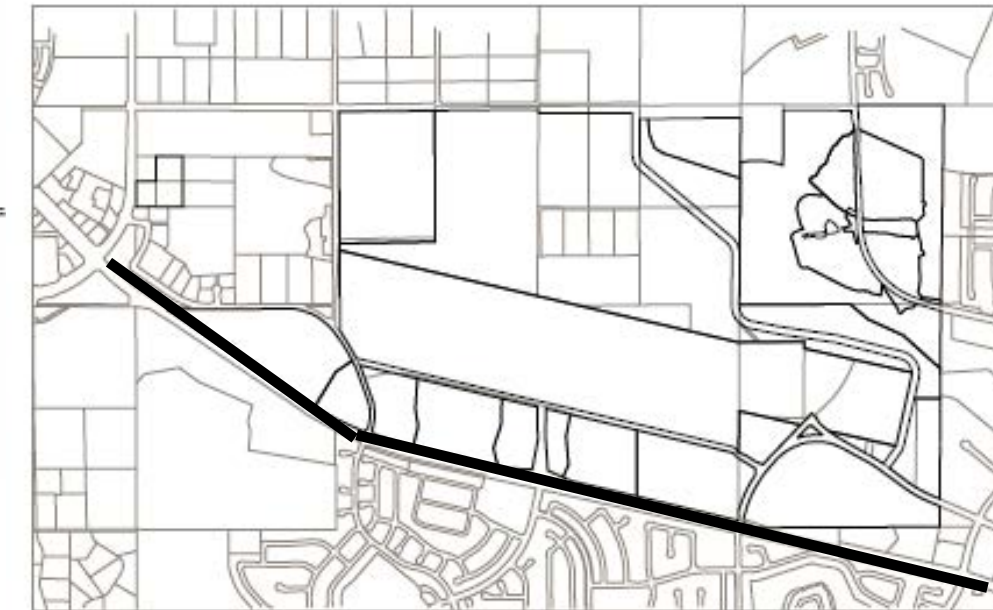
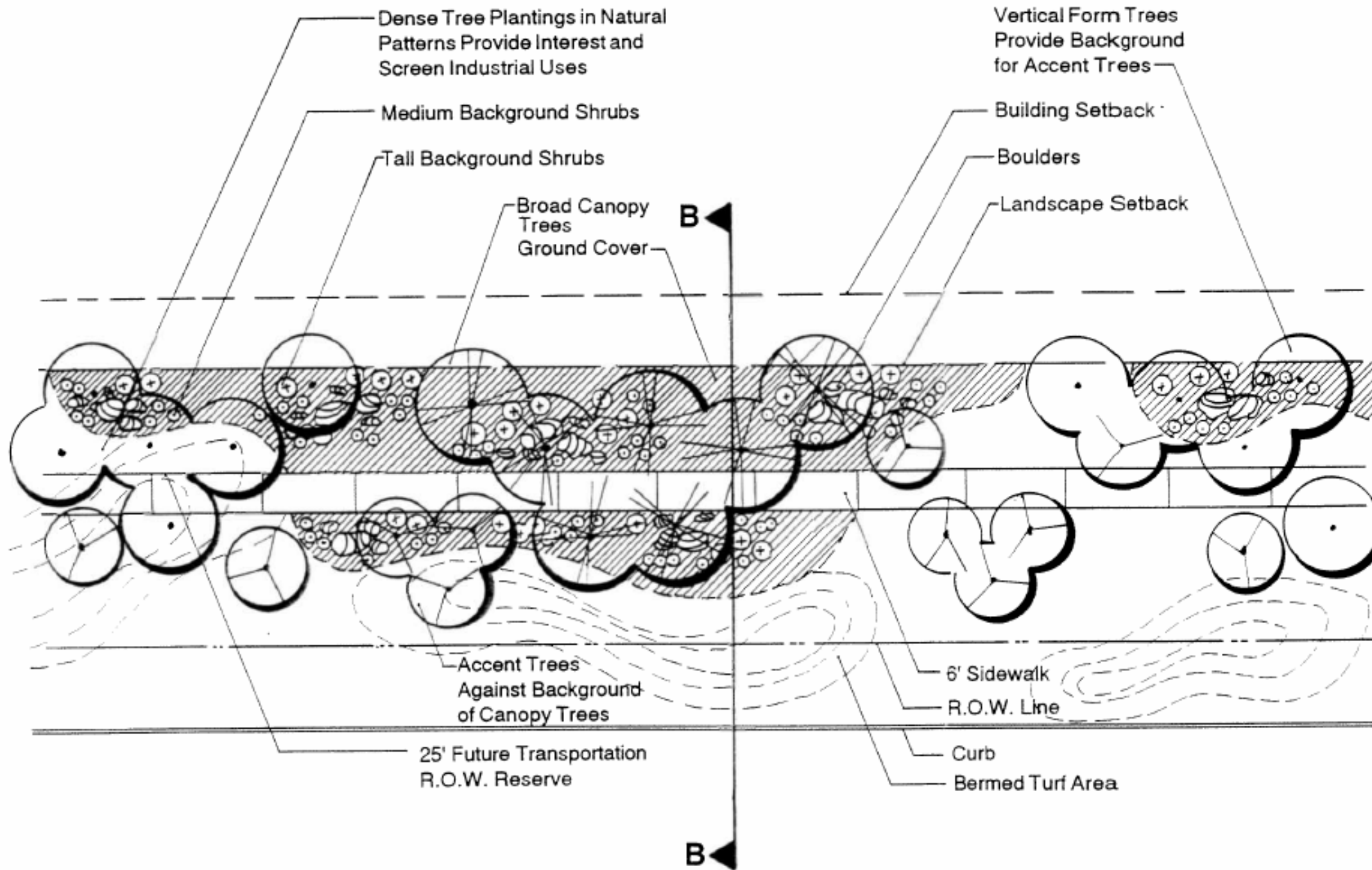

KEY MAP ———

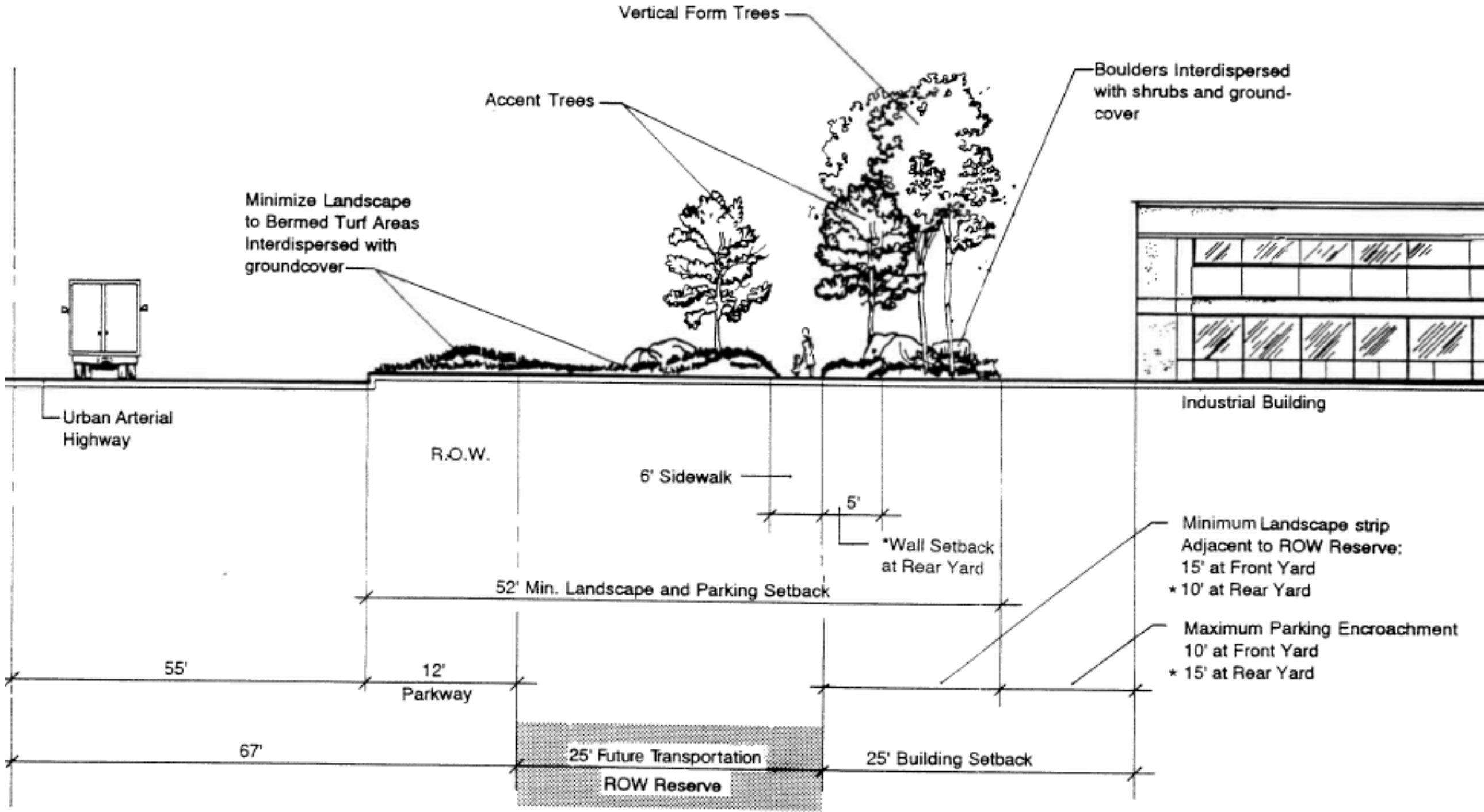



**Section IV: Landscape Design Guidelines**

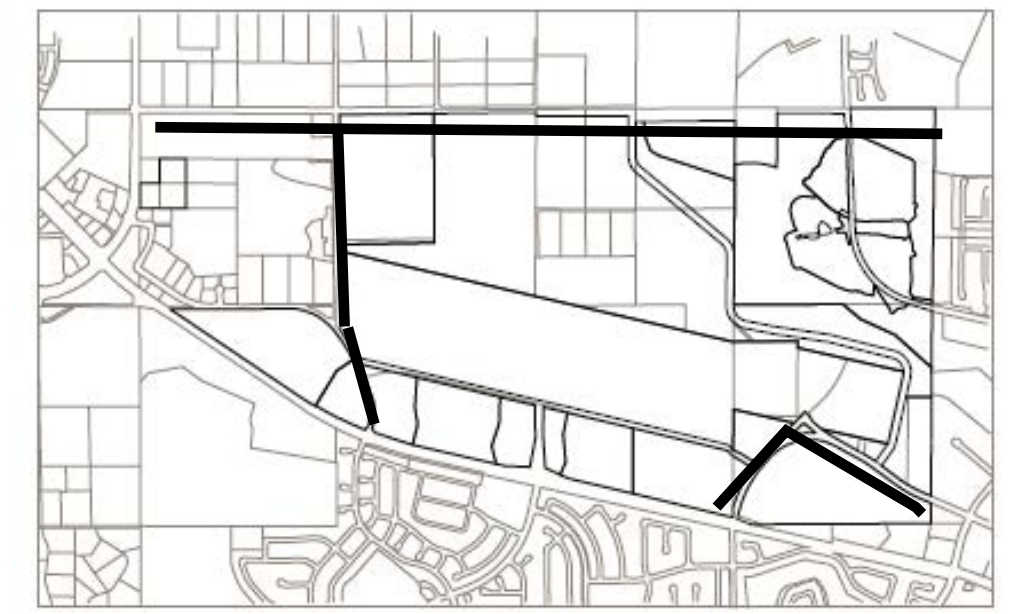
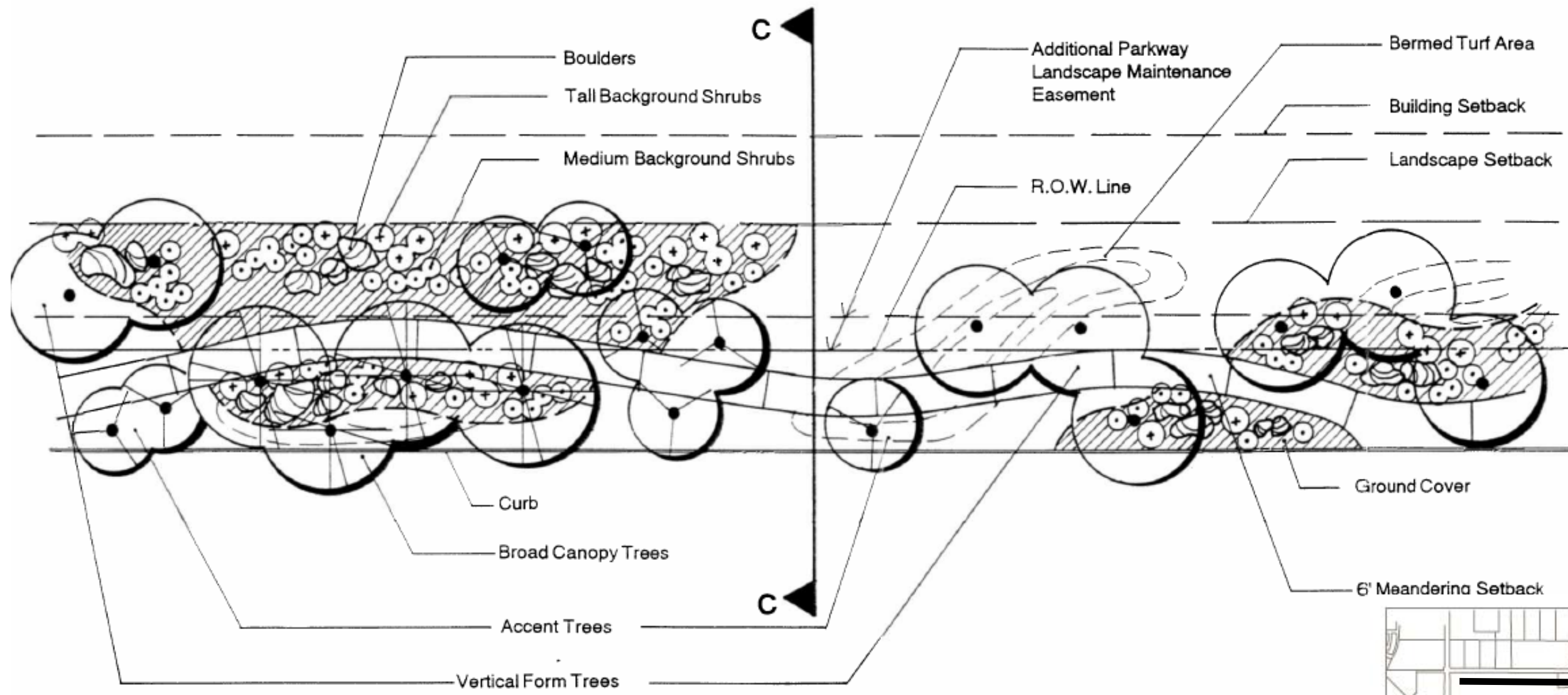

**MAJOR AND SECONDARY HIGHWAY PLAN VIEW  
(SKY CANYON DRIVE, LEON ROAD, AND AULD ROAD) - FIGURE IV-61**

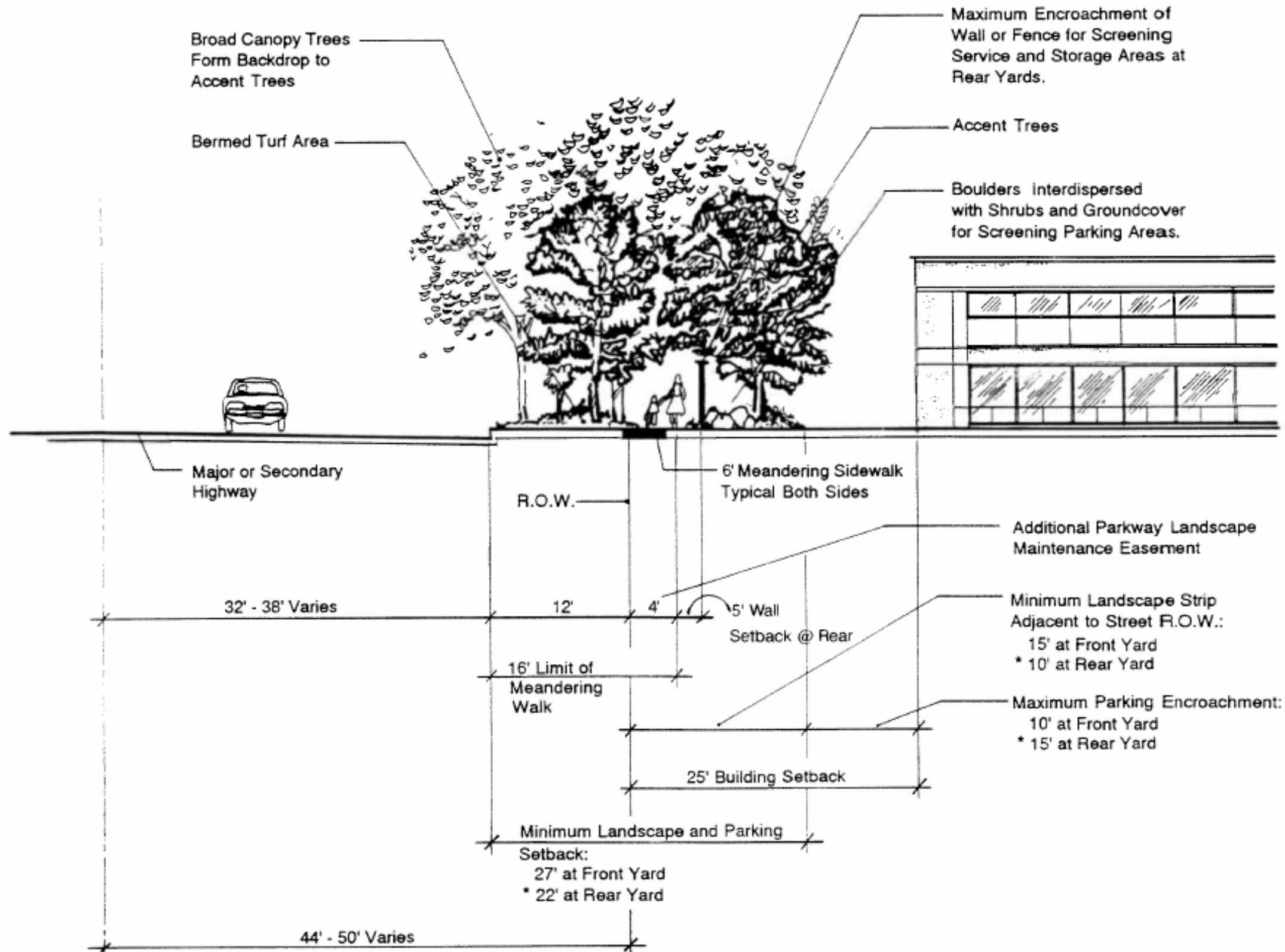



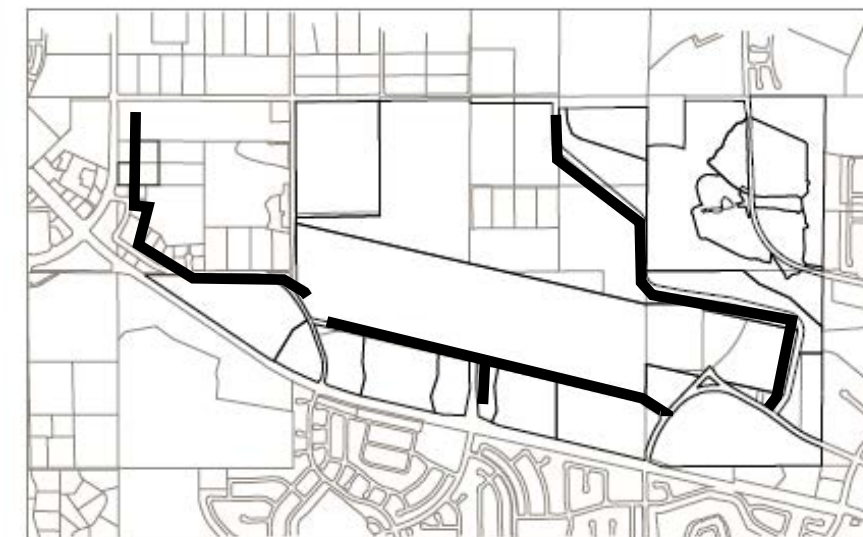
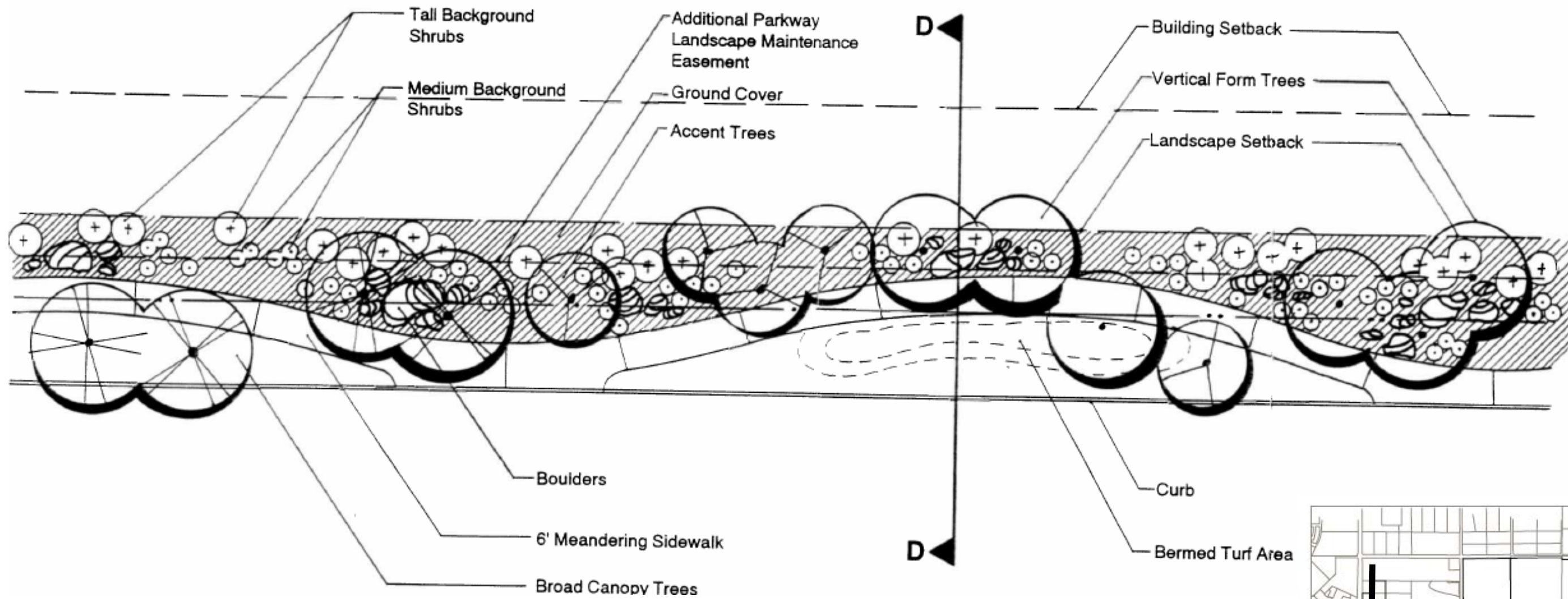

KEY MAP ———

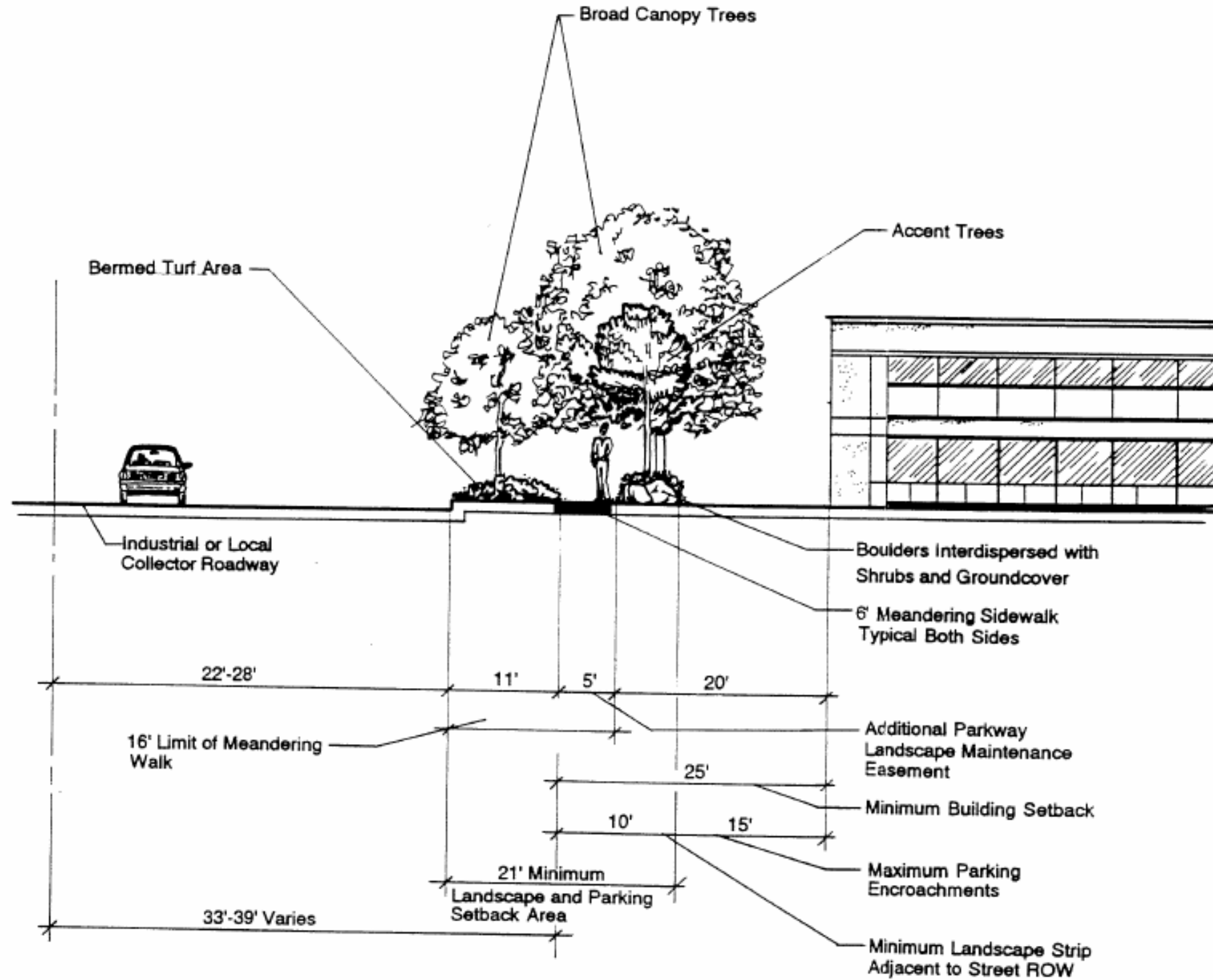

INDUSTRIAL AND LOCAL COLLECTOR ROADWAY SECTION  
(BRIGGS ROAD, BOREL ROAD, AND SKY CANYON DRIVE) - FIGURE IV-64



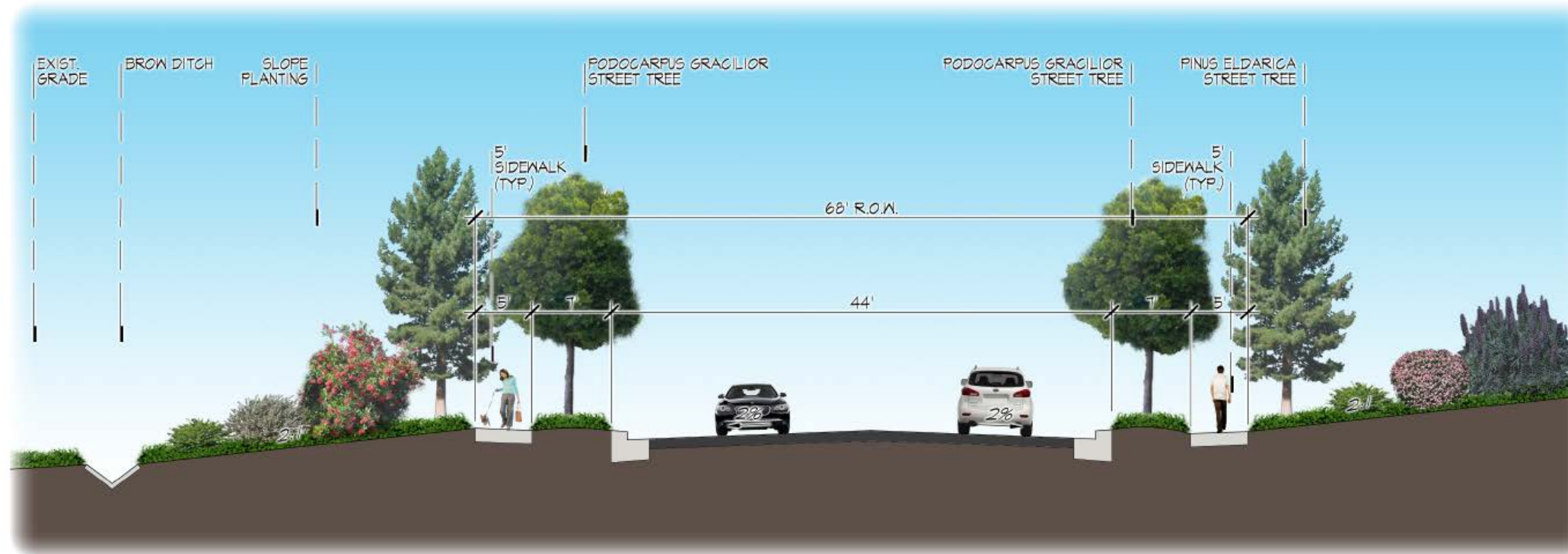
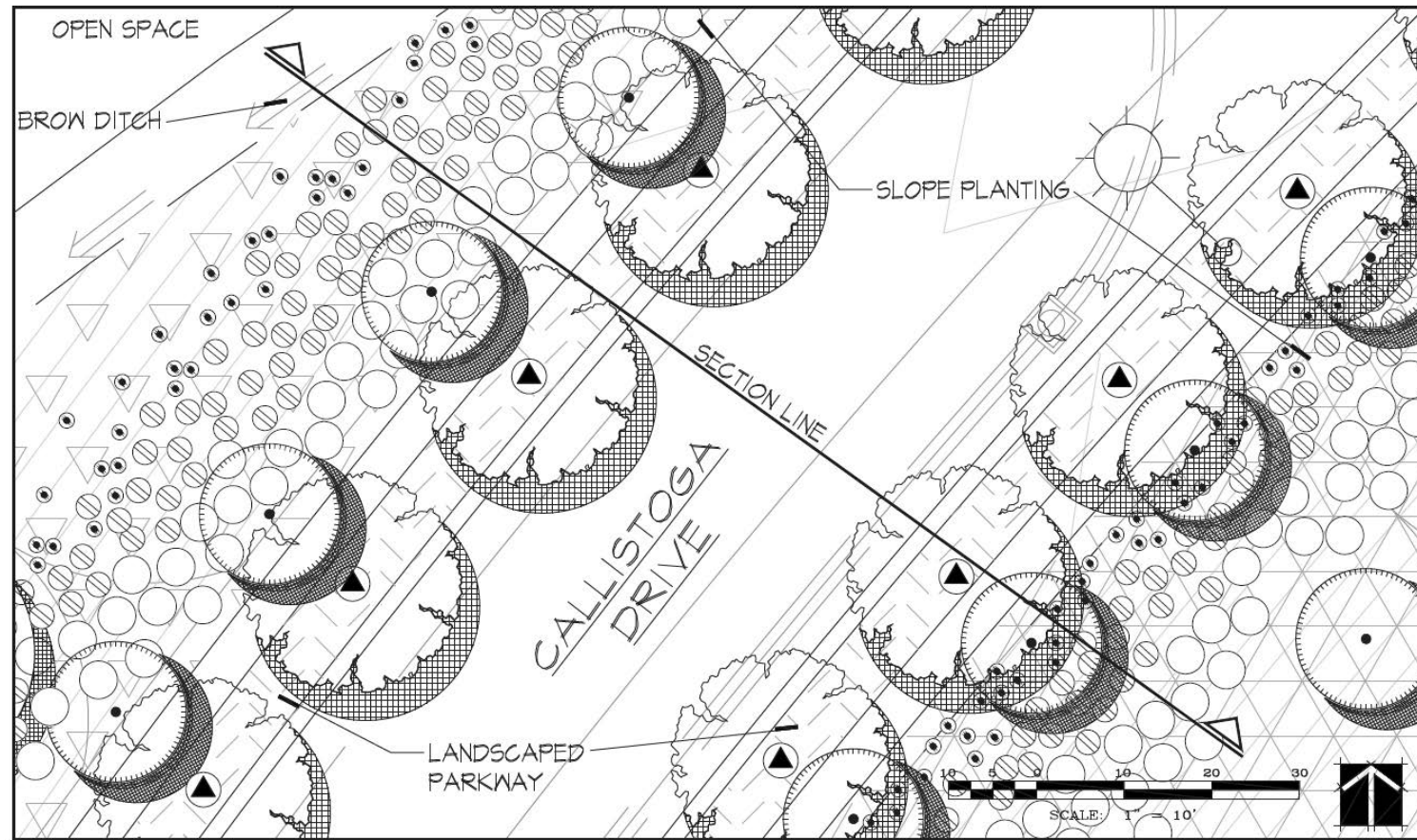



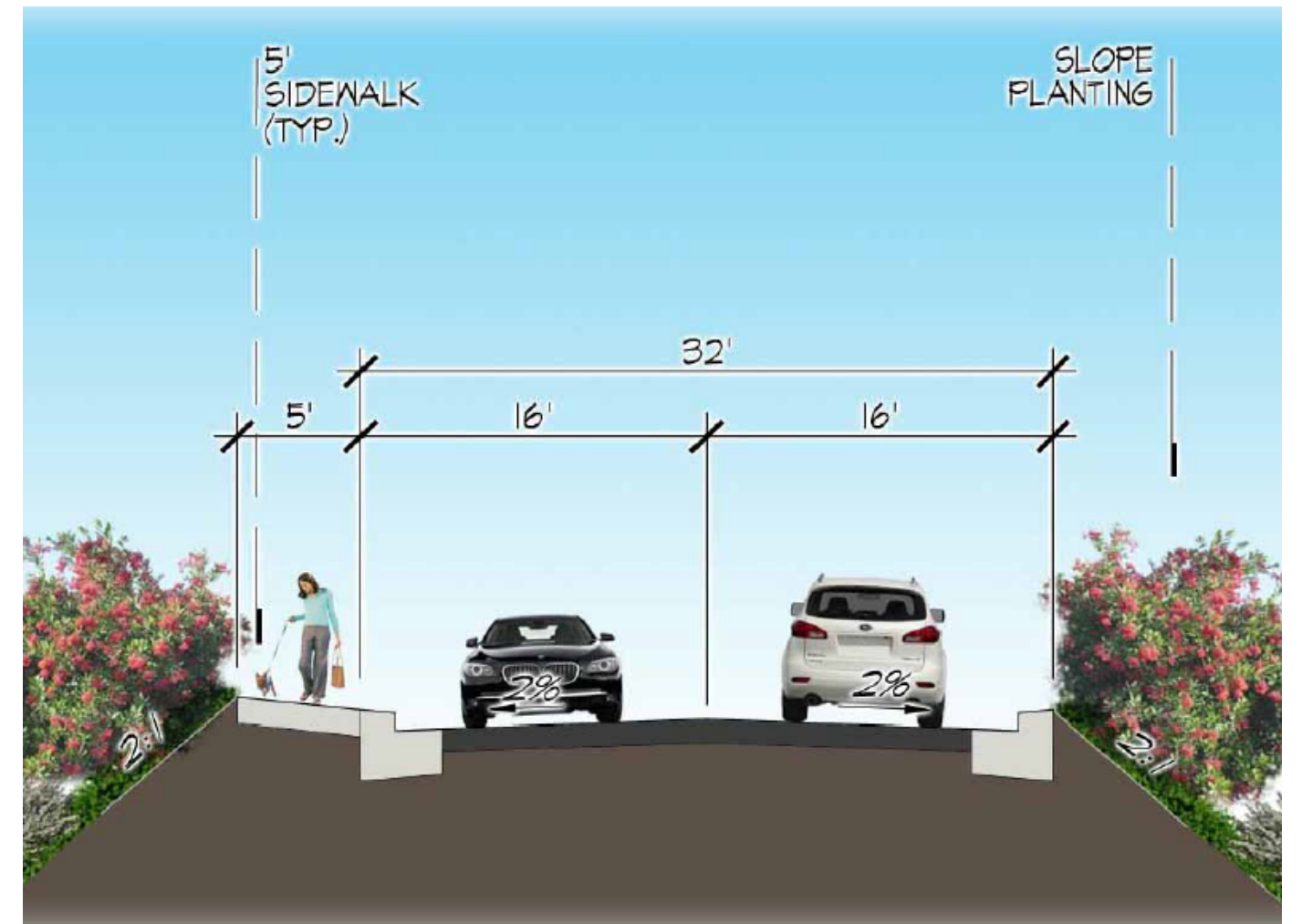
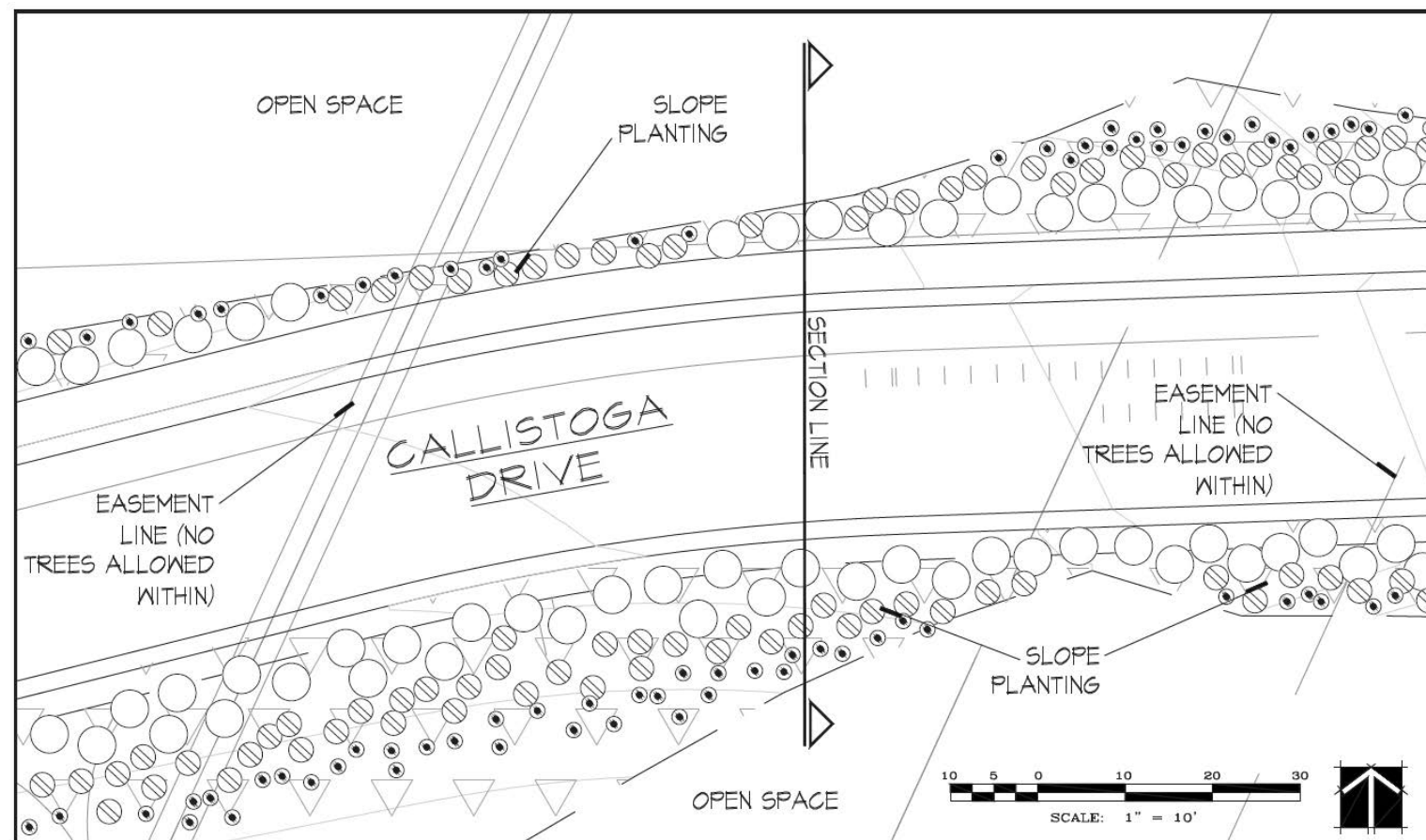



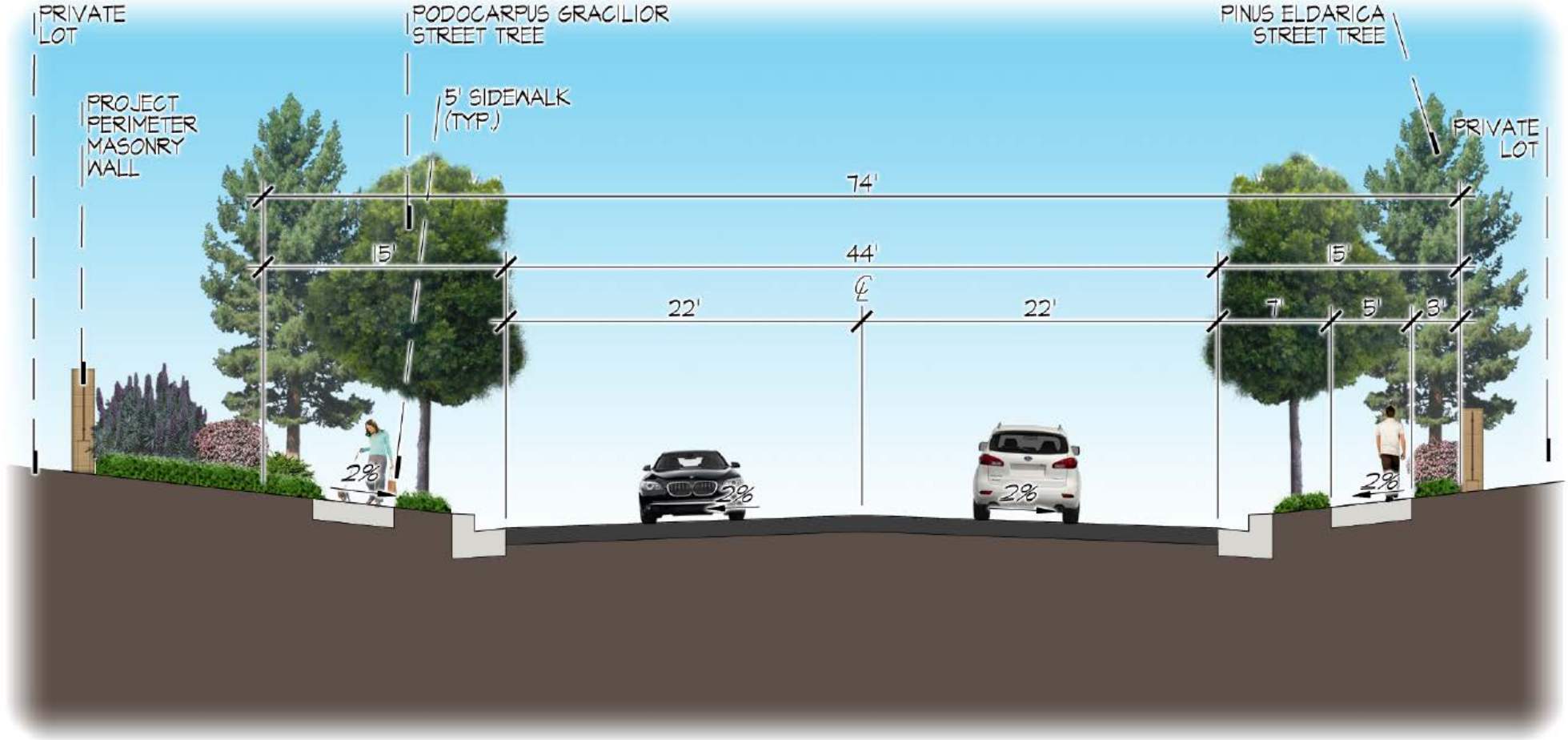
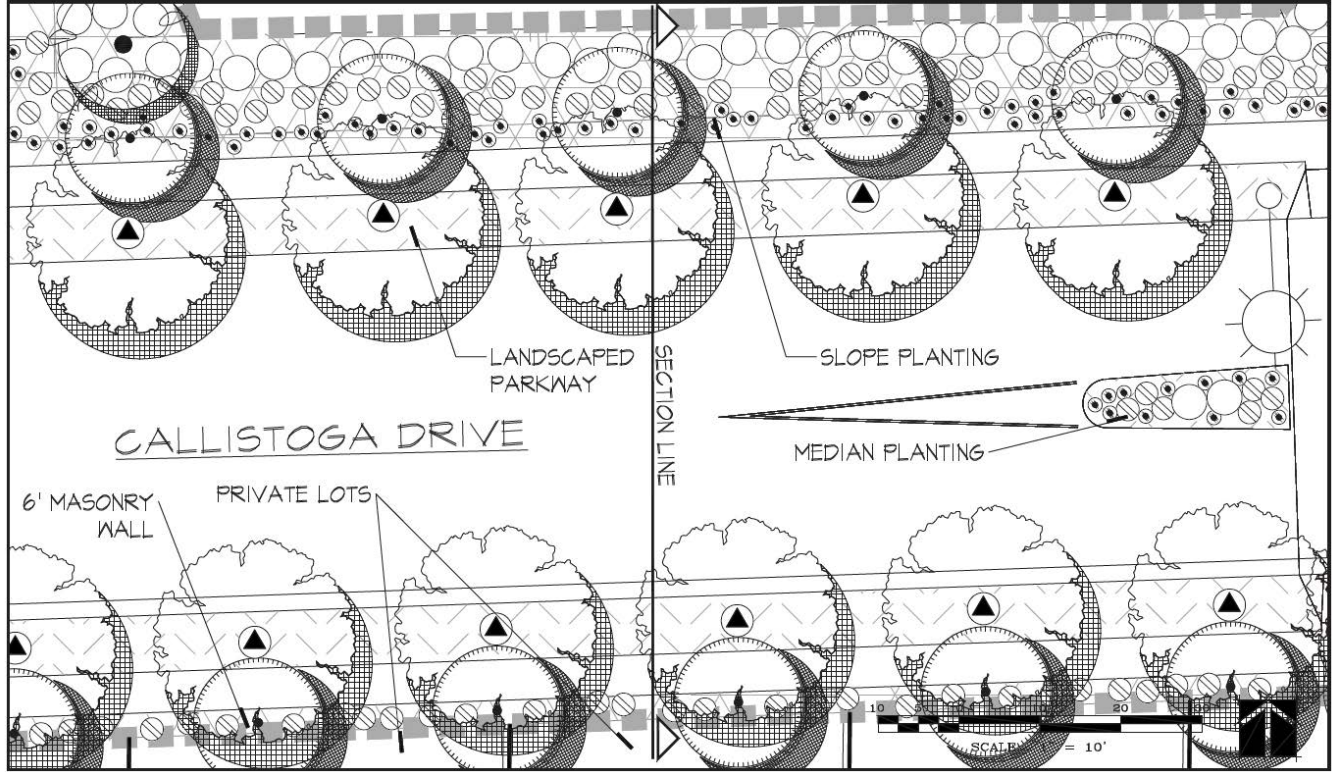

Section IV: Landscape Design Guidelines

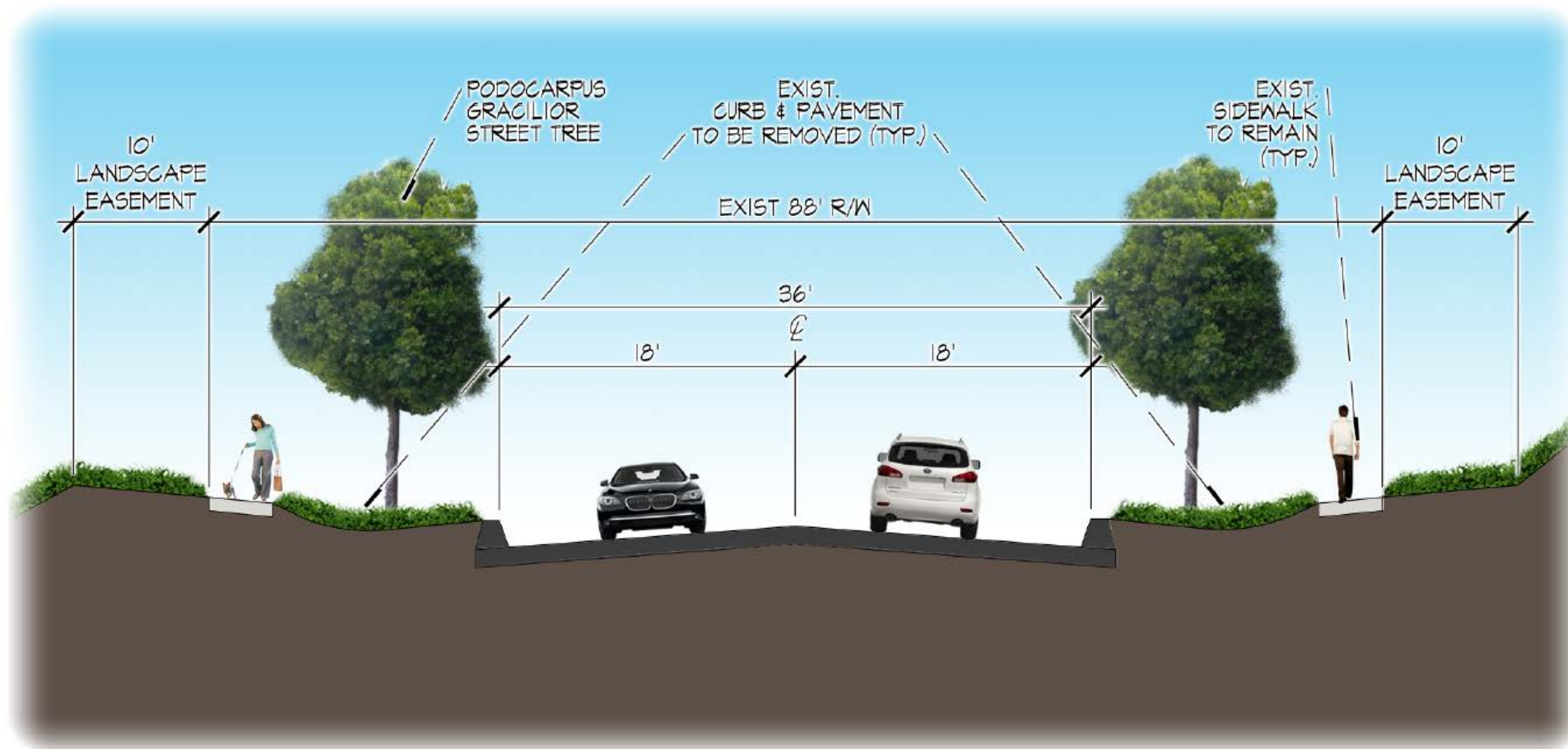
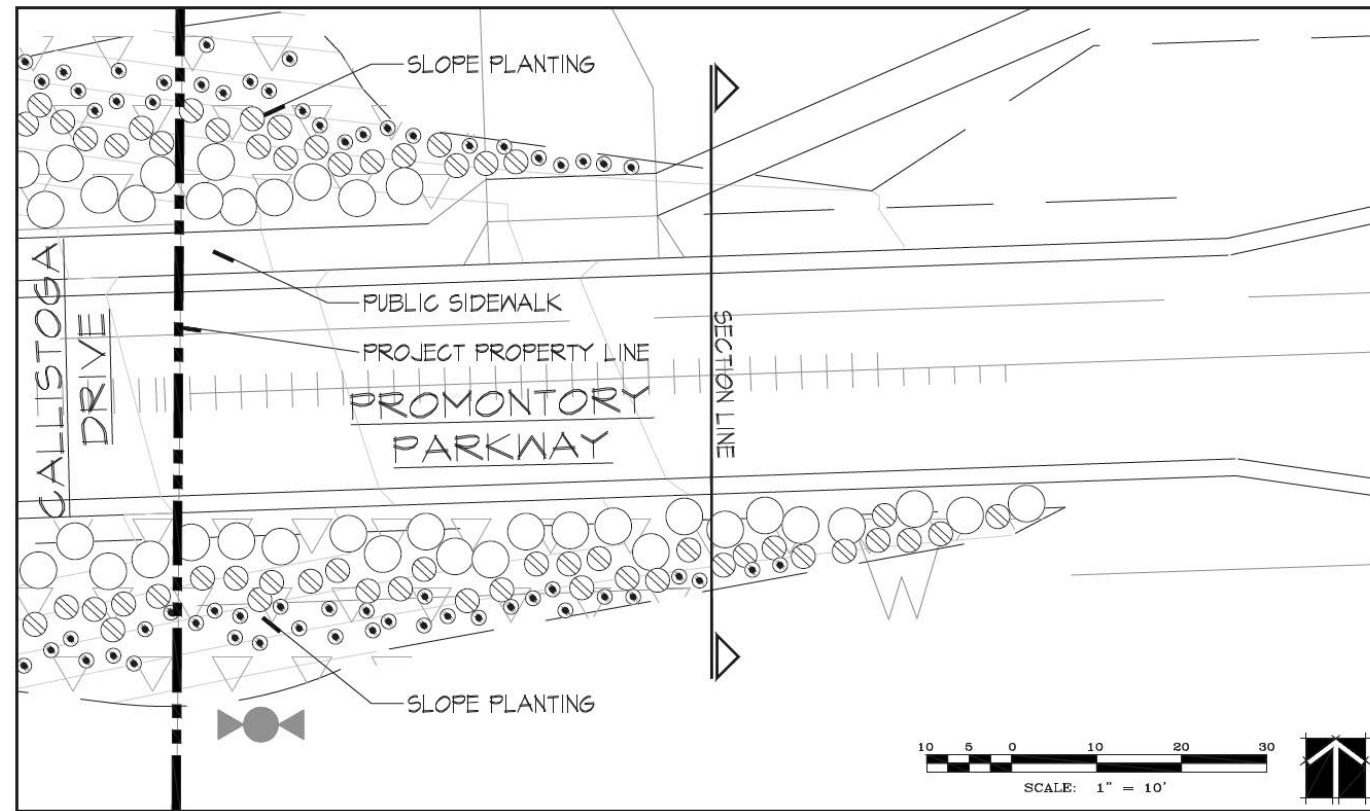



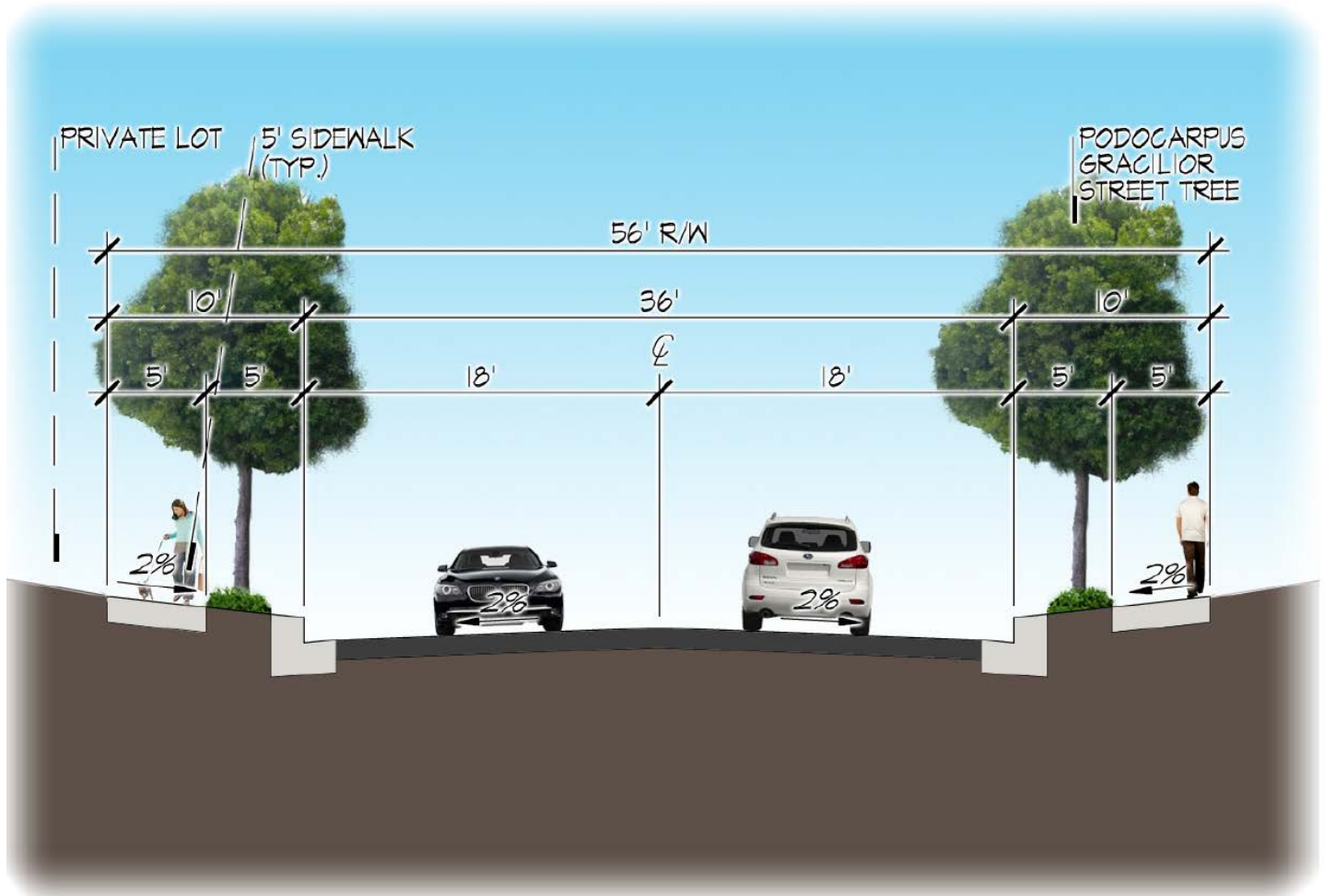
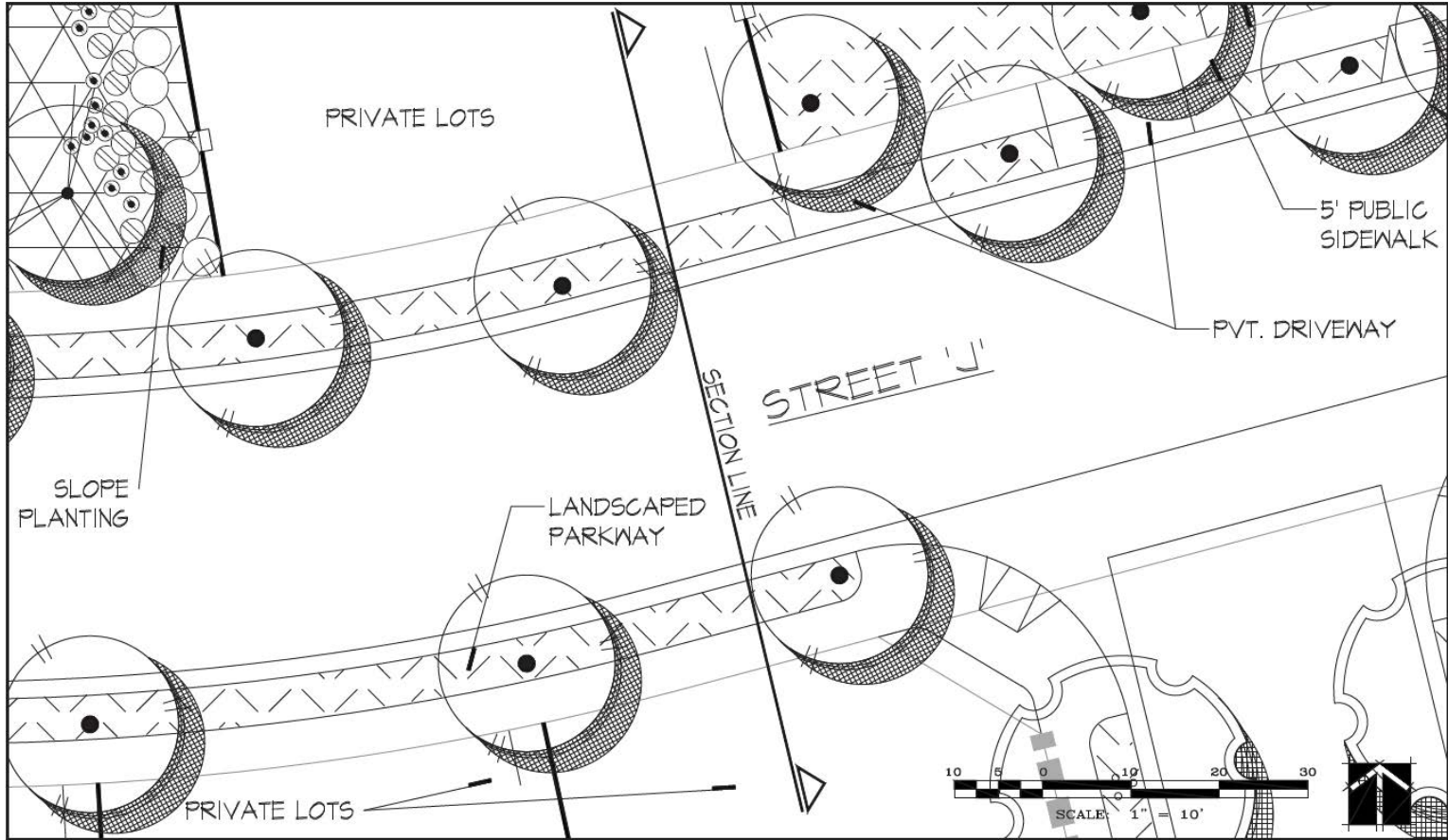



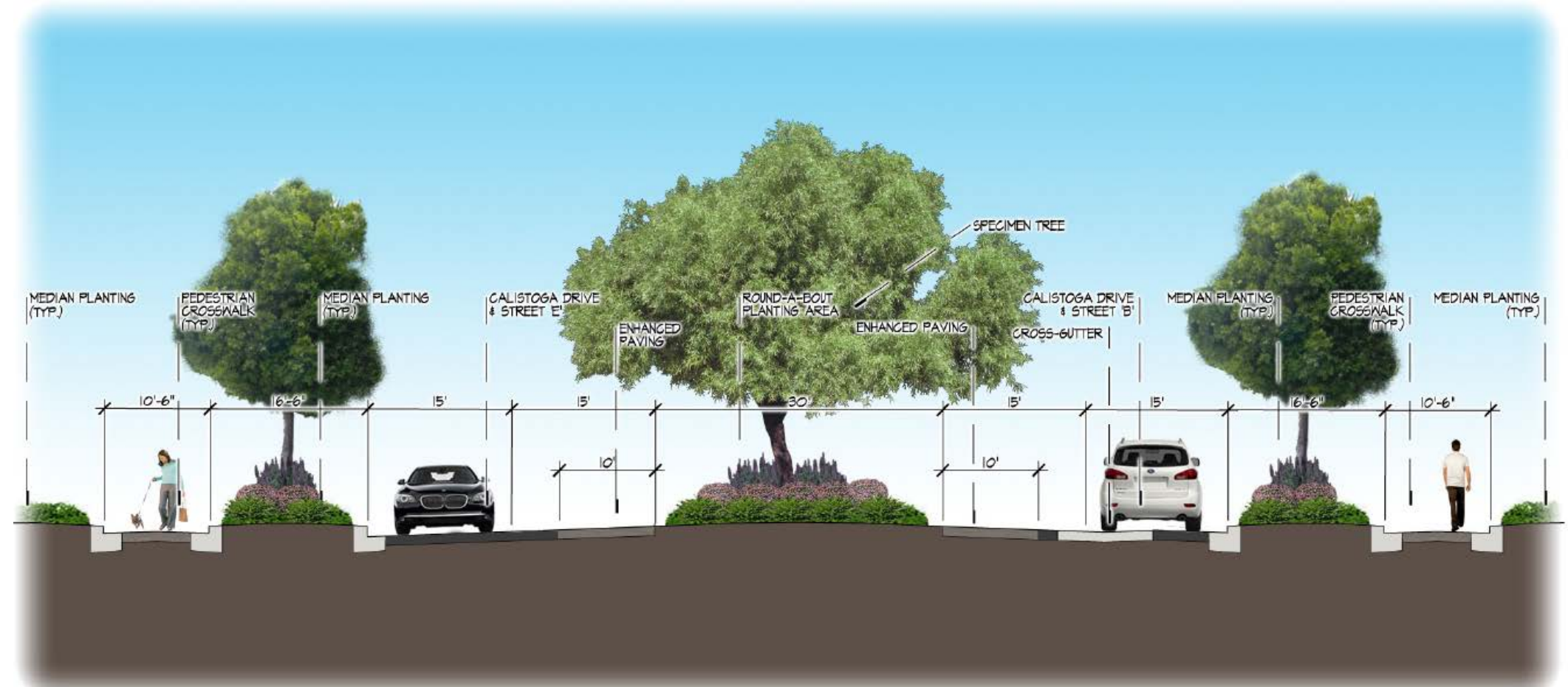
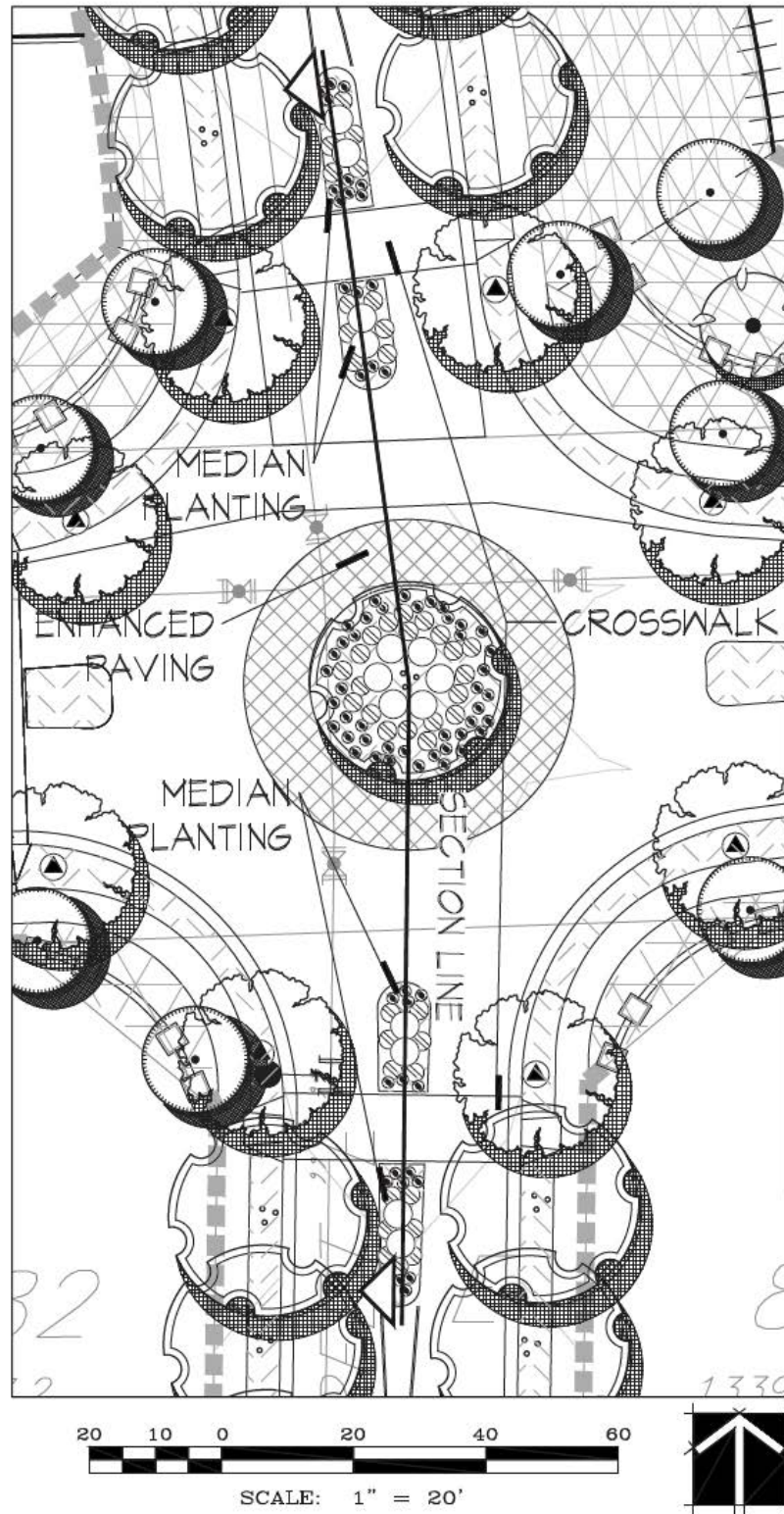



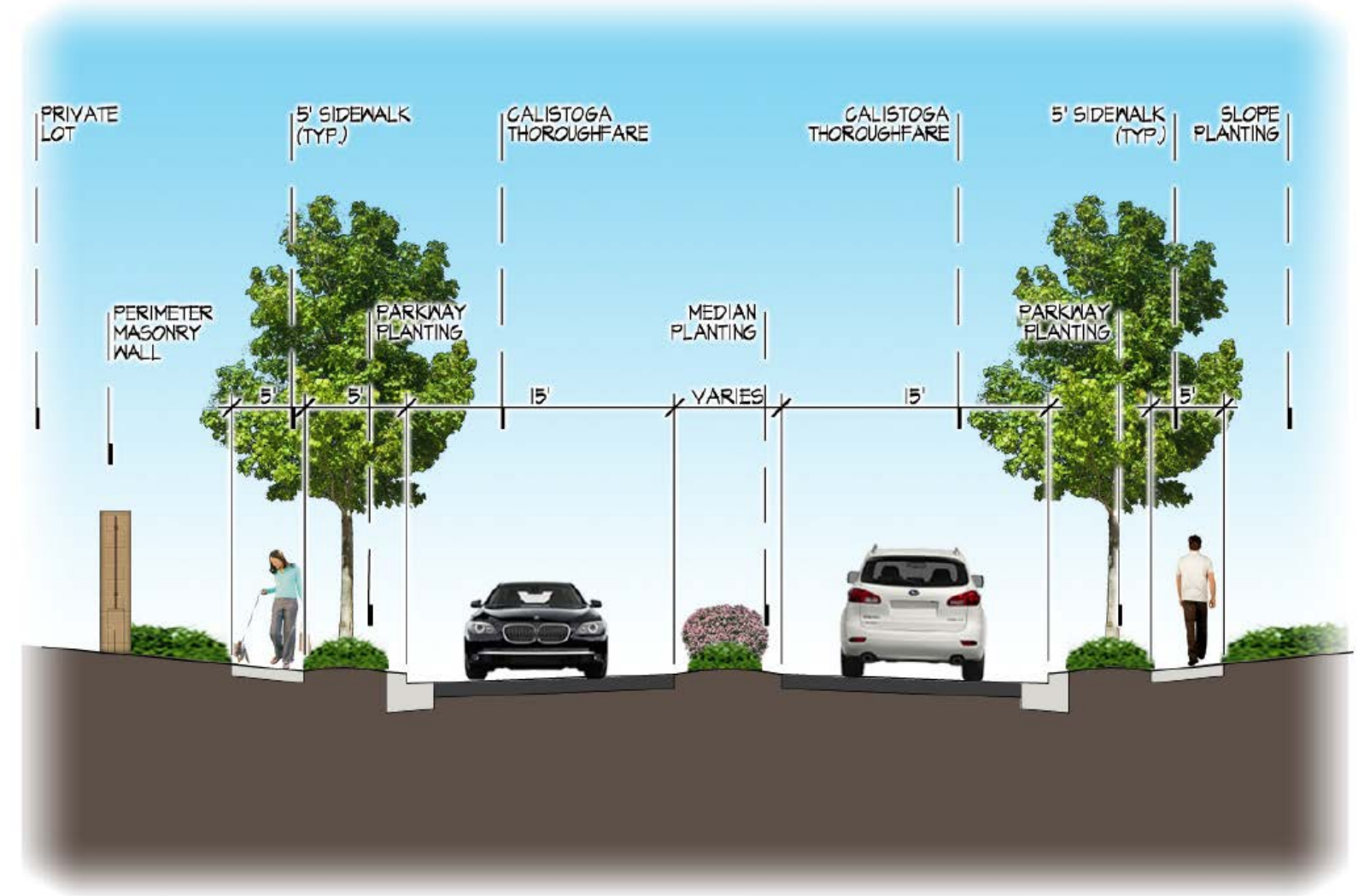
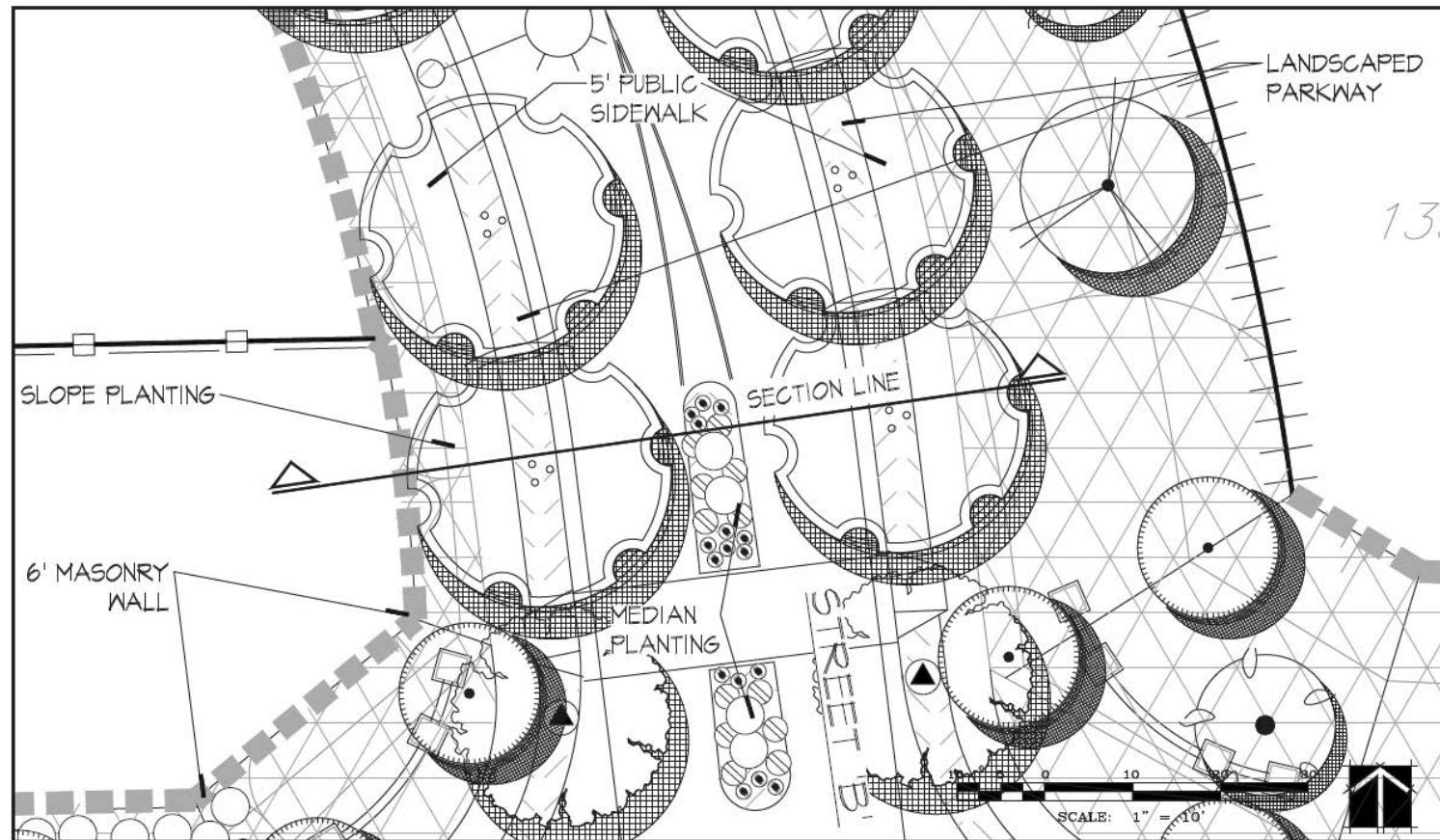

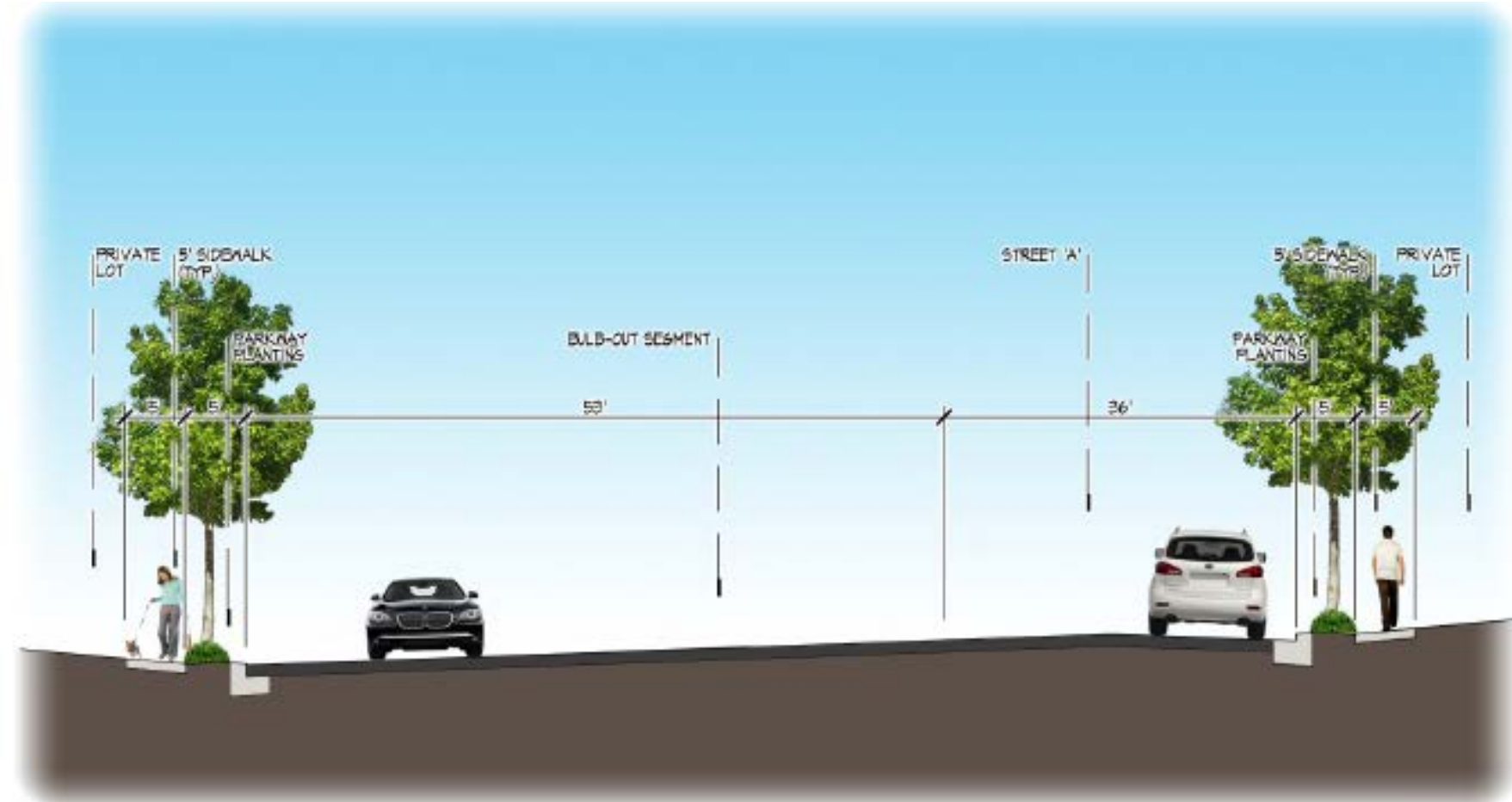
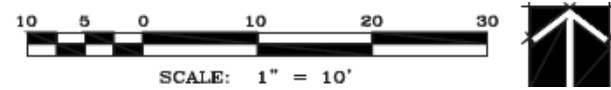
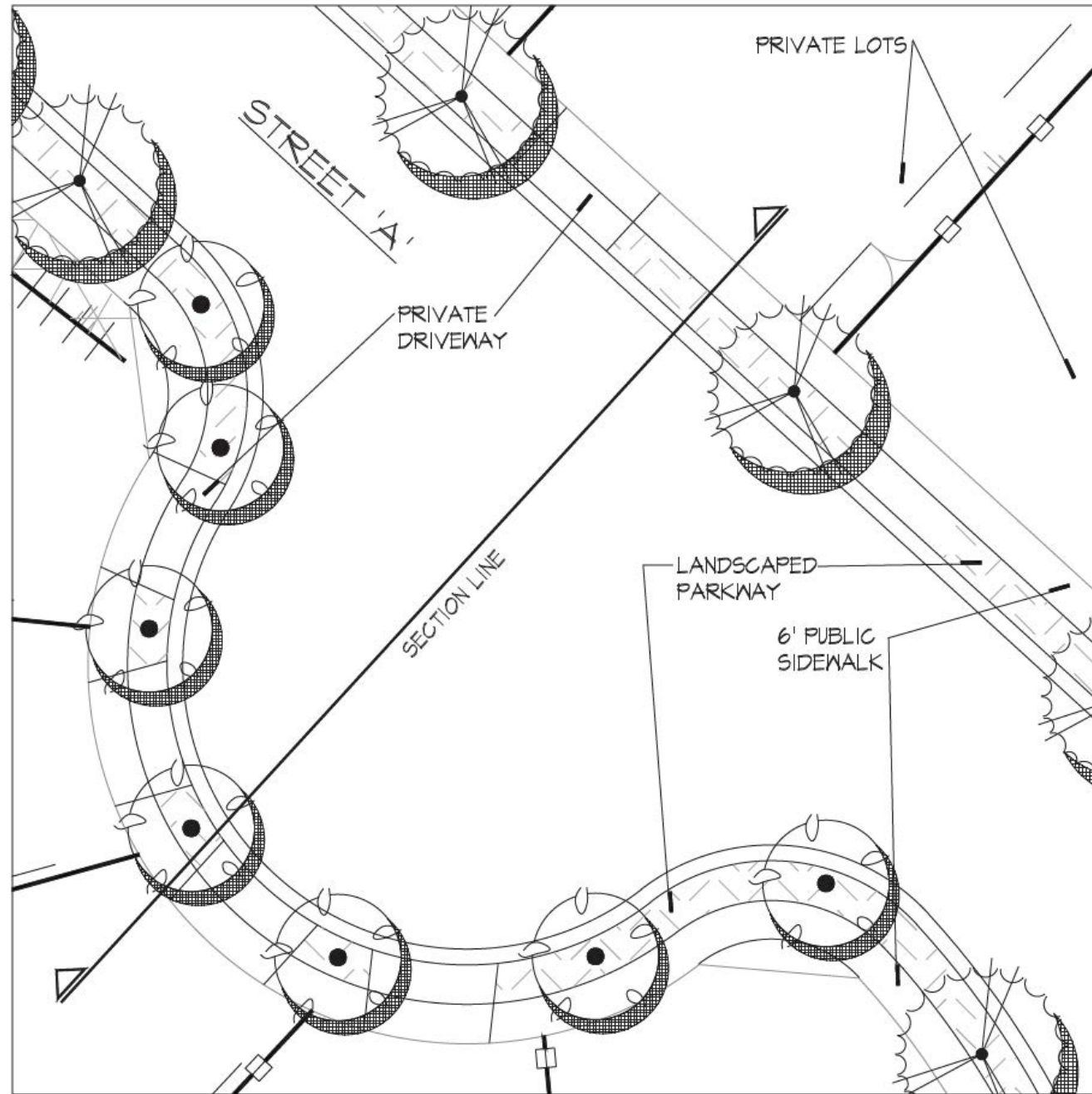



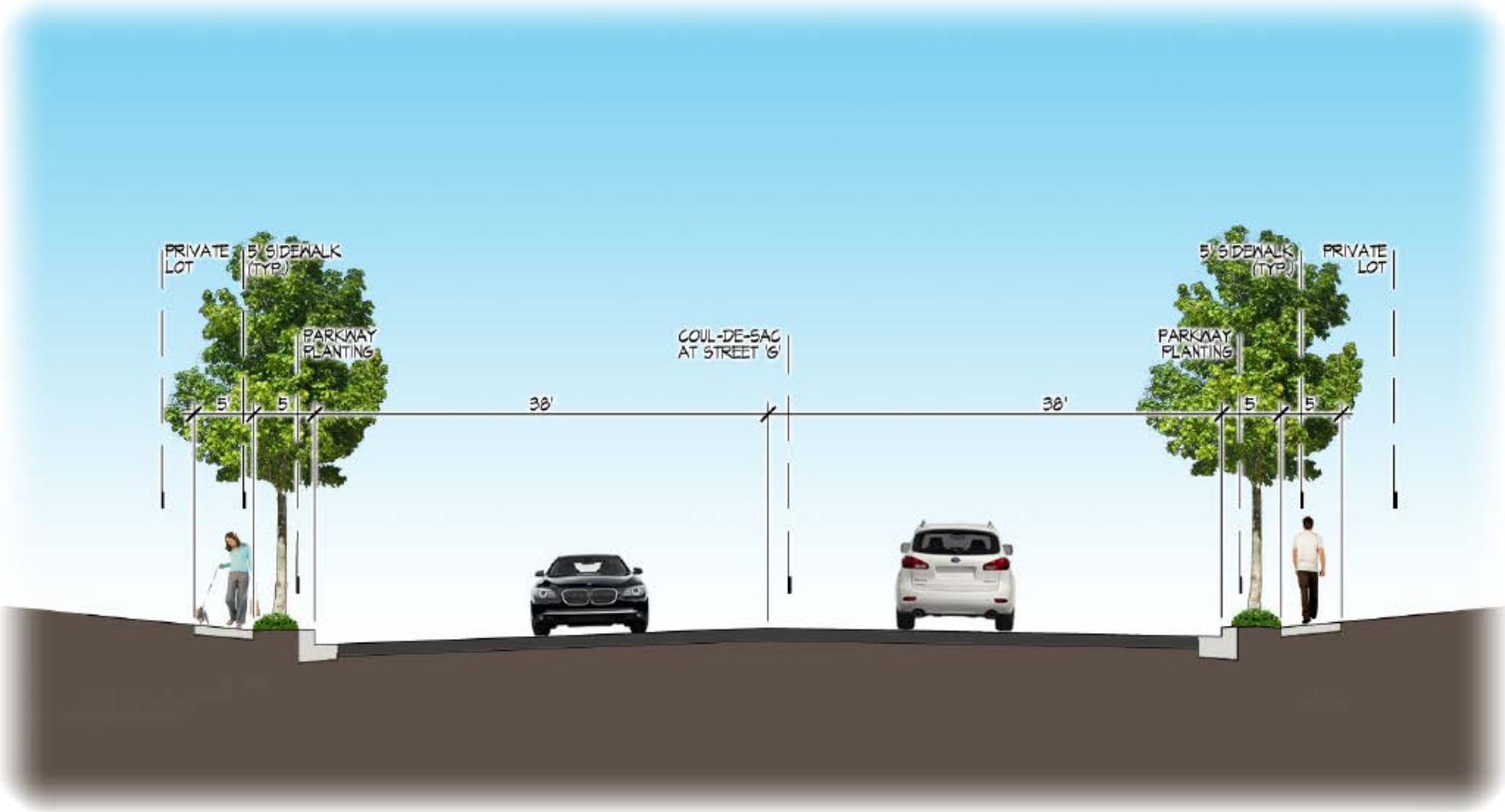
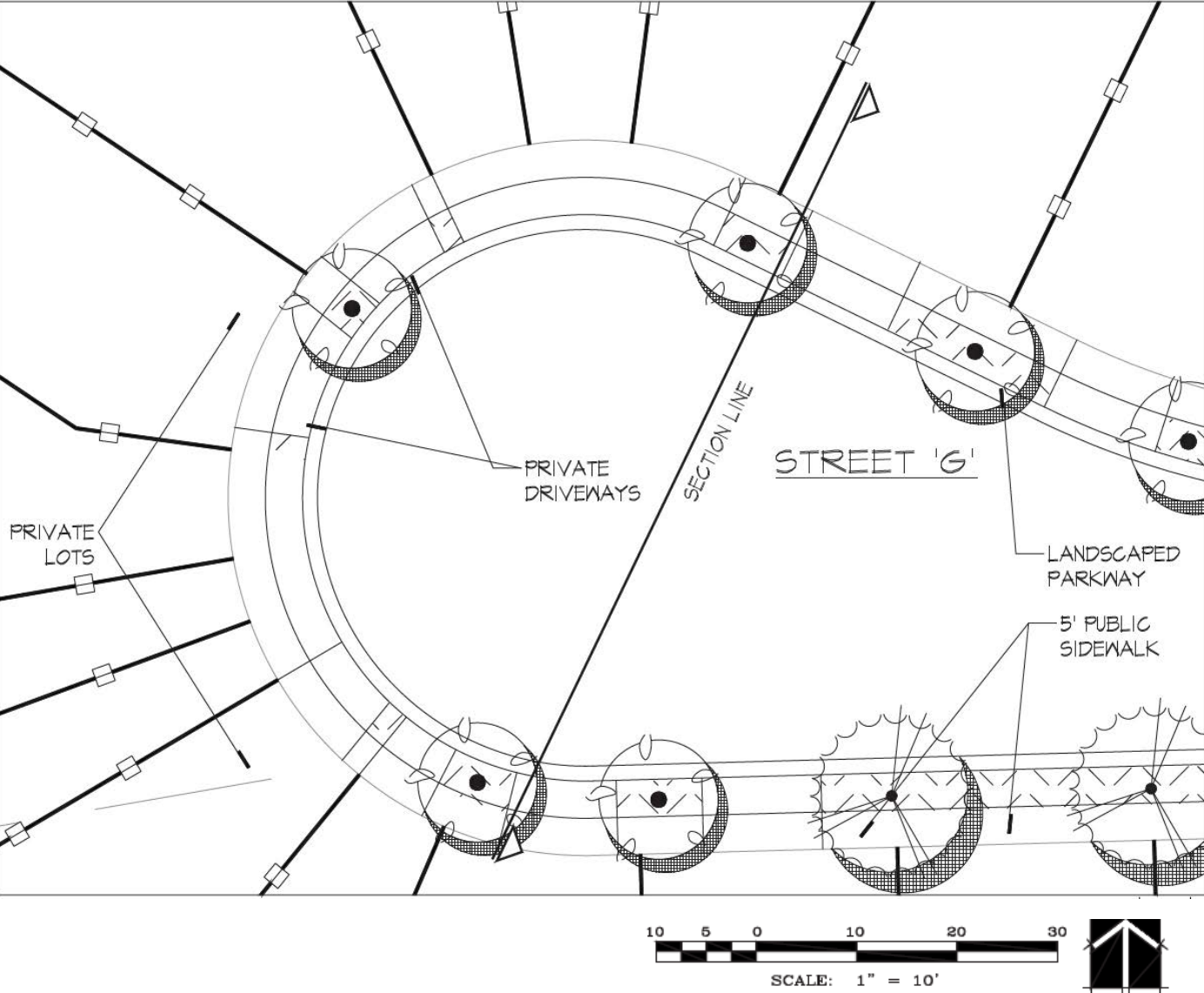

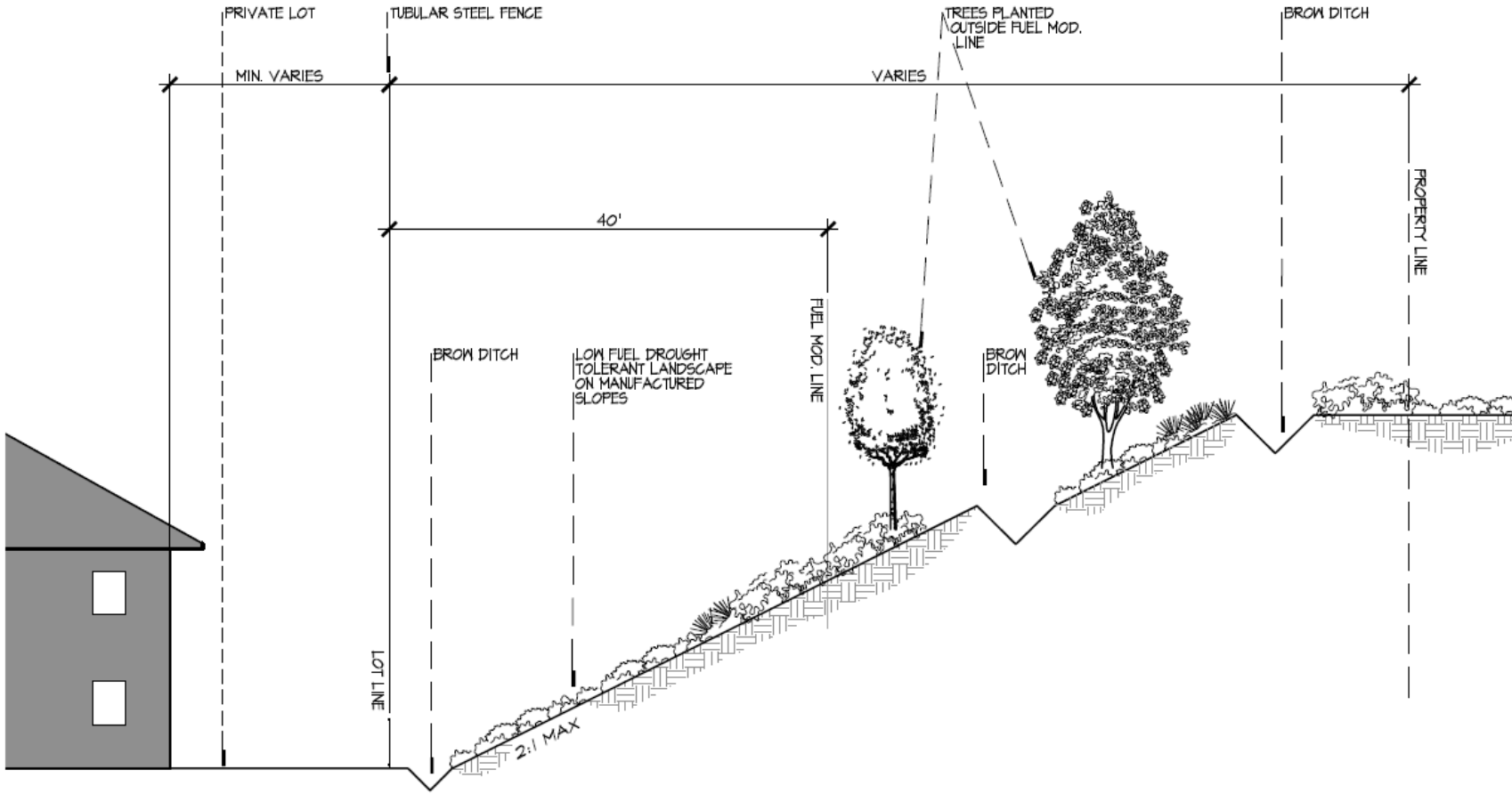
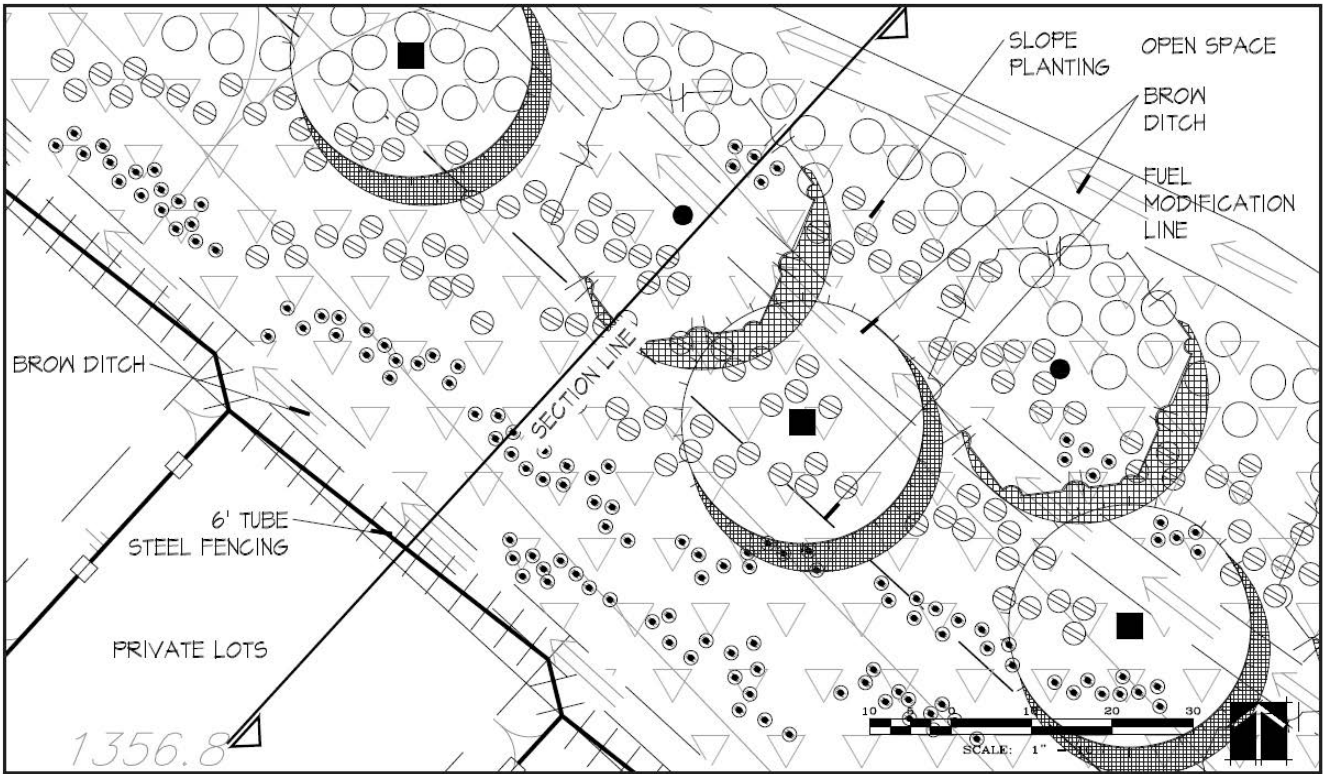

PA14

PA19



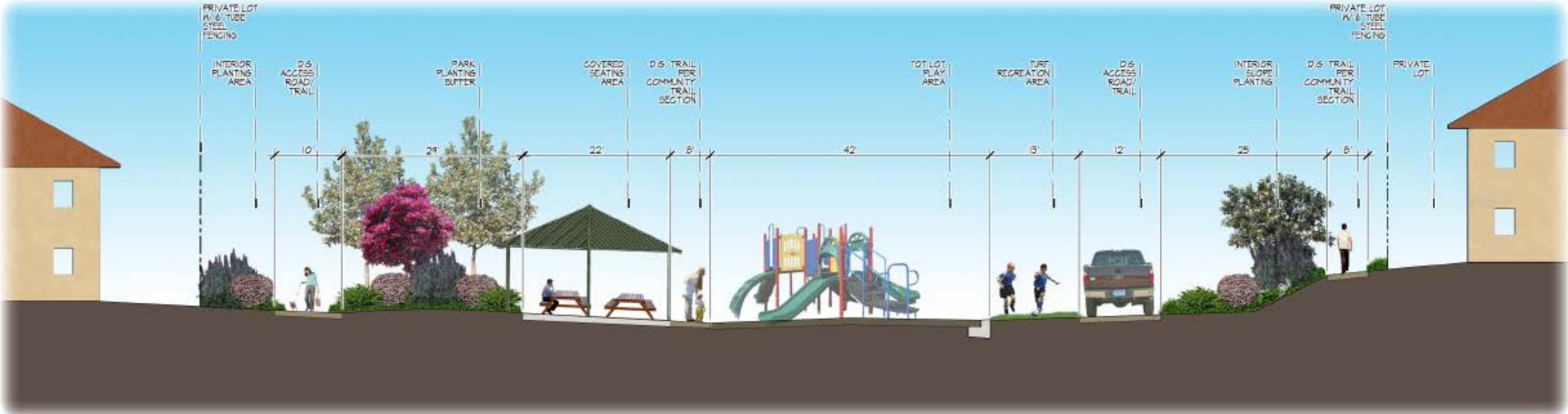
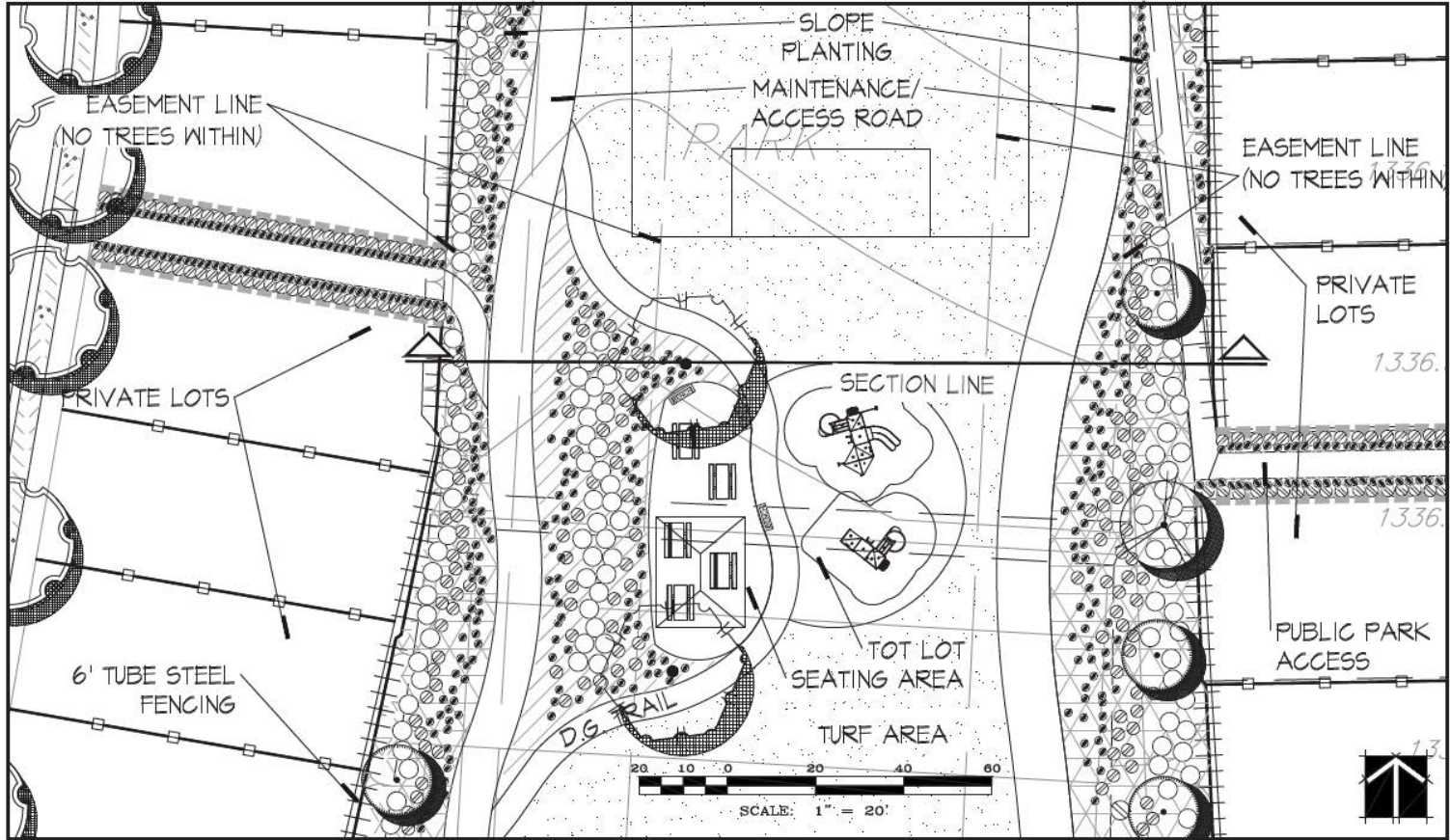

PA16

PA22

PA15

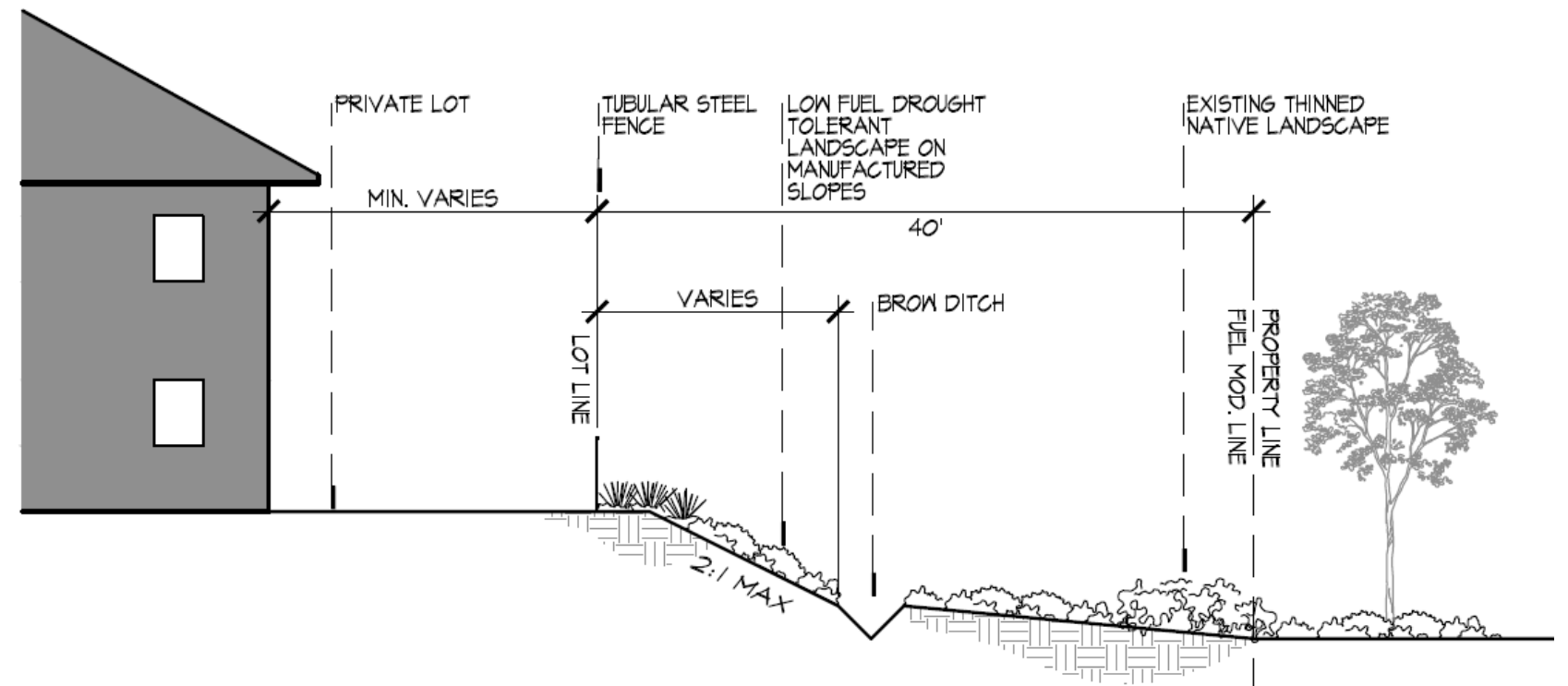
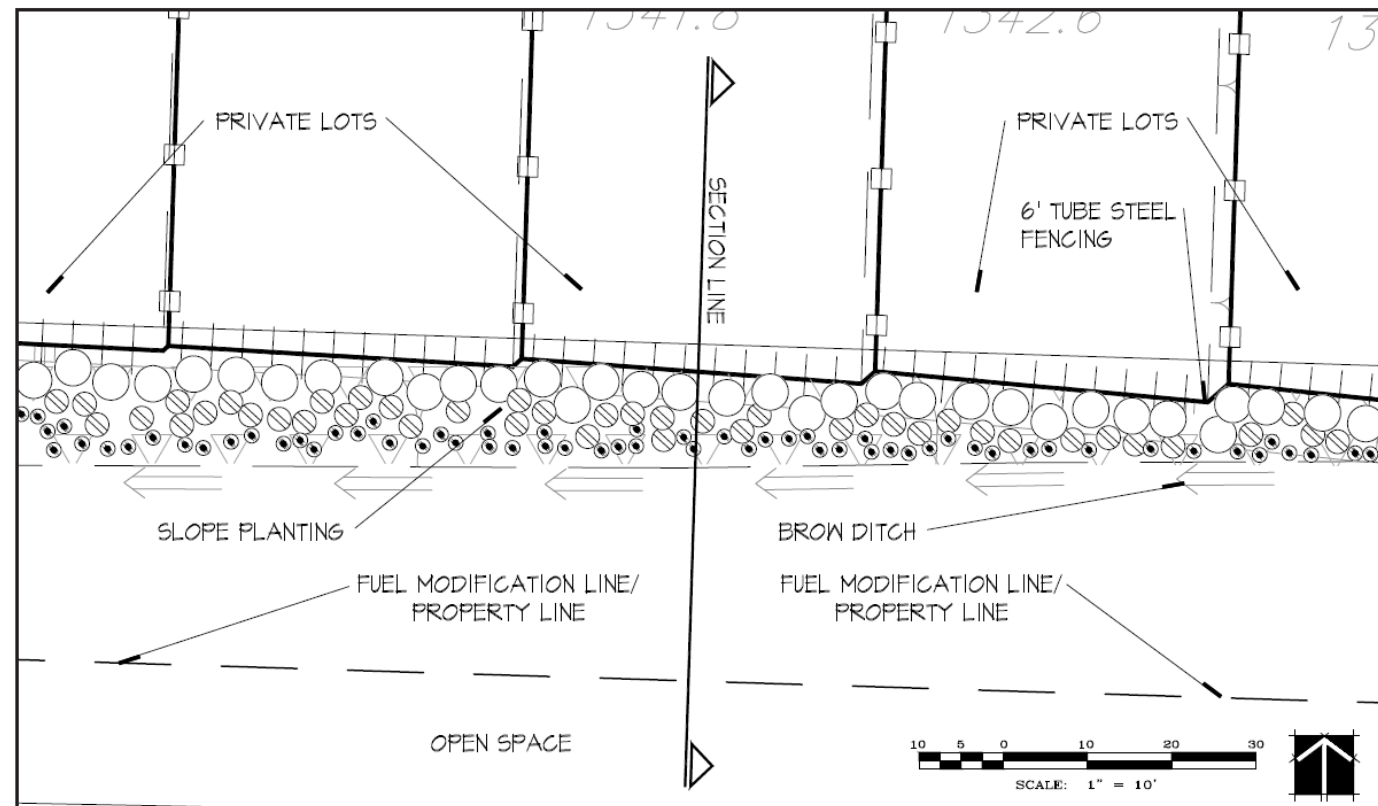

PA15

PA21

PA15 MEDIUM HIGH DENSITY RESIDENTIAL - PA21 OPEN SPACE CONSERVATION EDGE CONDITION - FIGURE IV-74



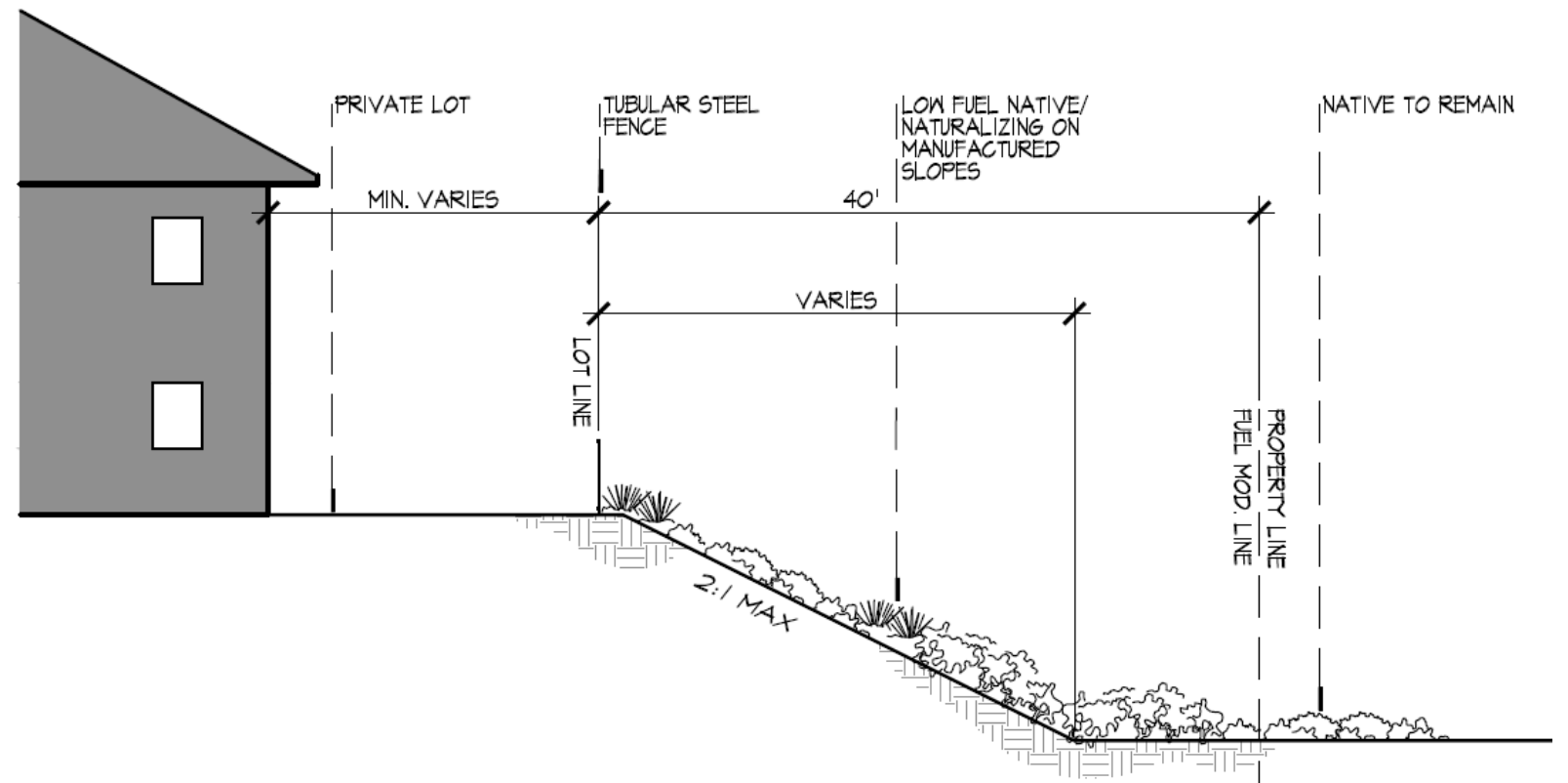
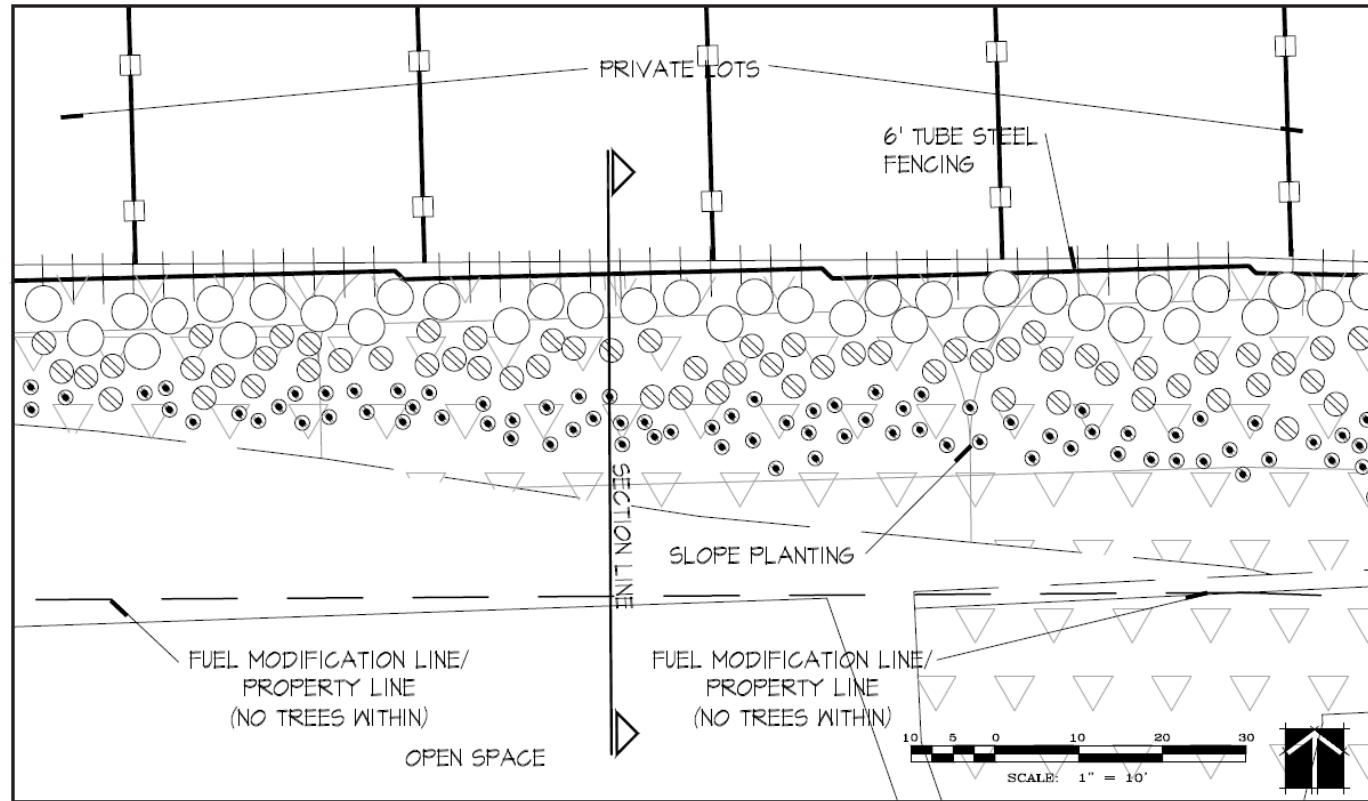

PA16

PA21

PA16 MEDIUM HIGH DENSITY RESIDENTIAL - PA21 OPEN SPACE CONSERVATION EDGE CONDITION - FIGURE IV-75

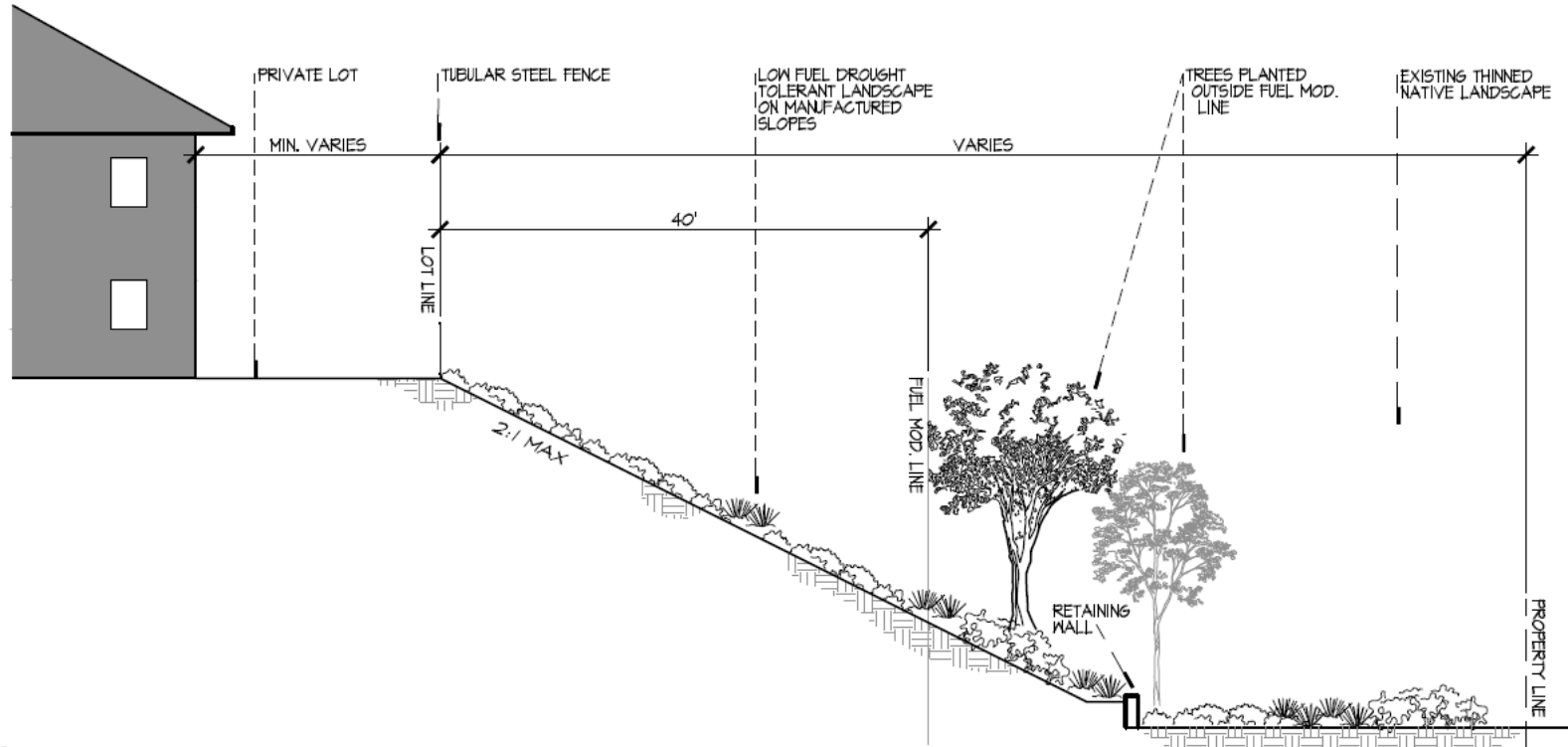
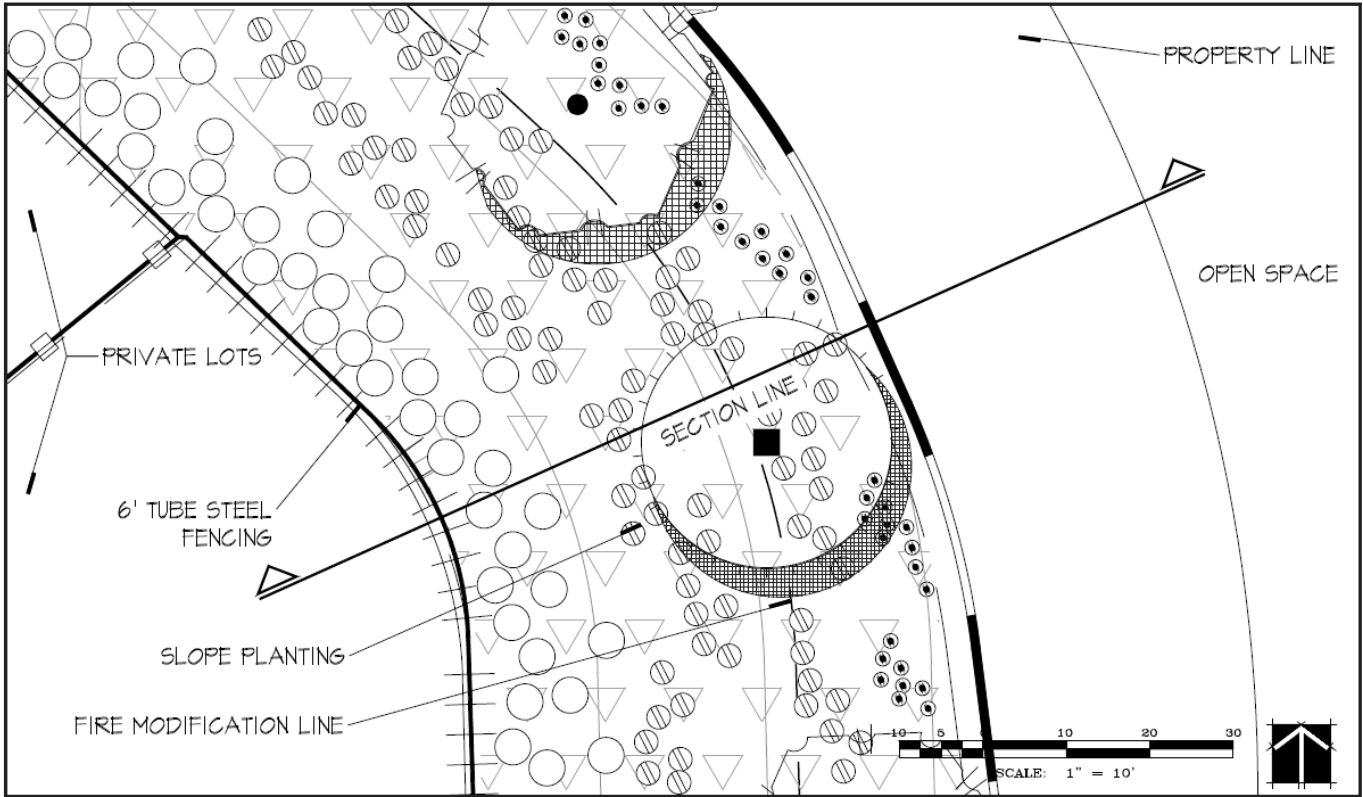

PA17

PA19



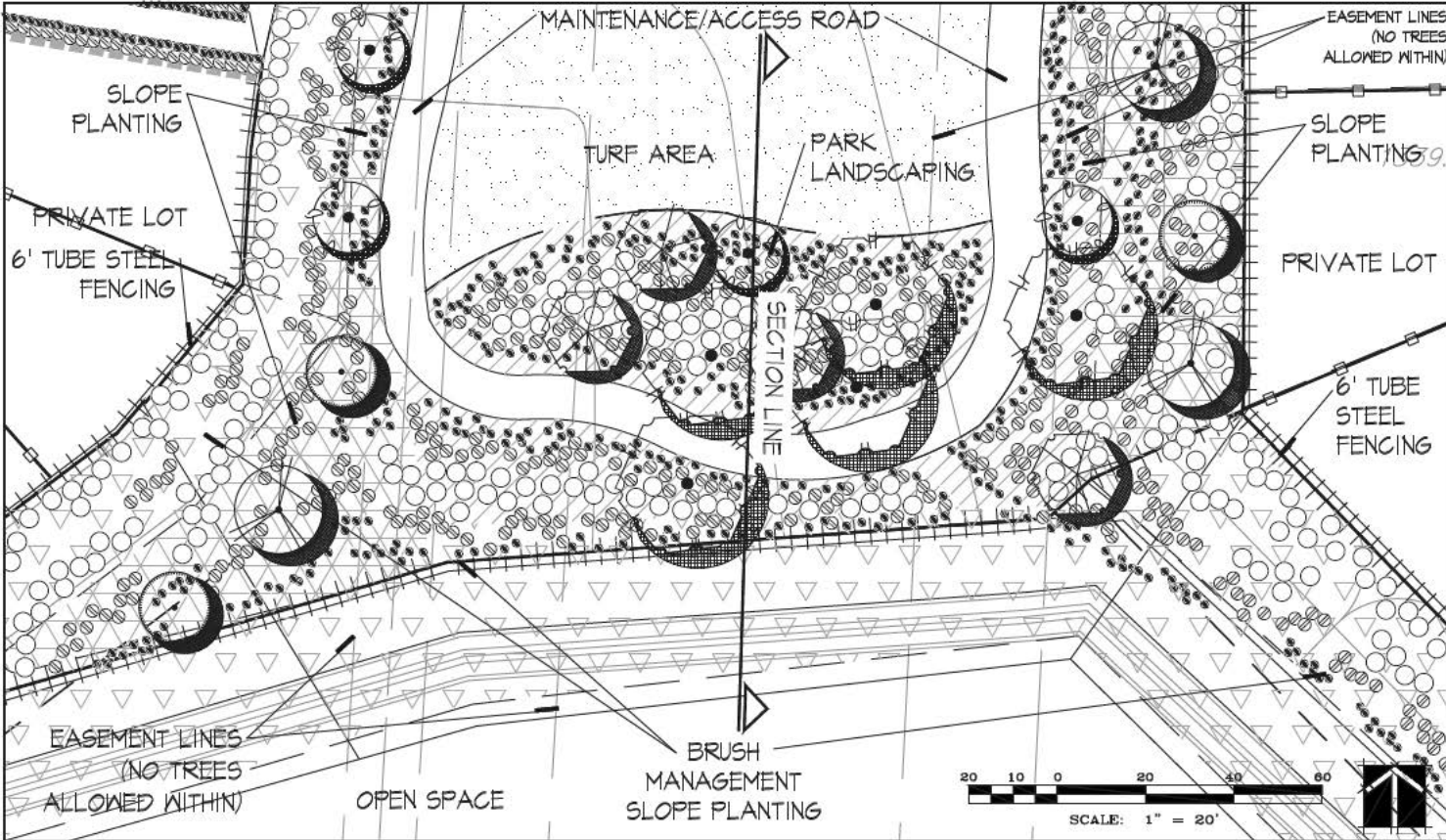

PA22

PA21



# Section IV: Landscape Design Guidelines

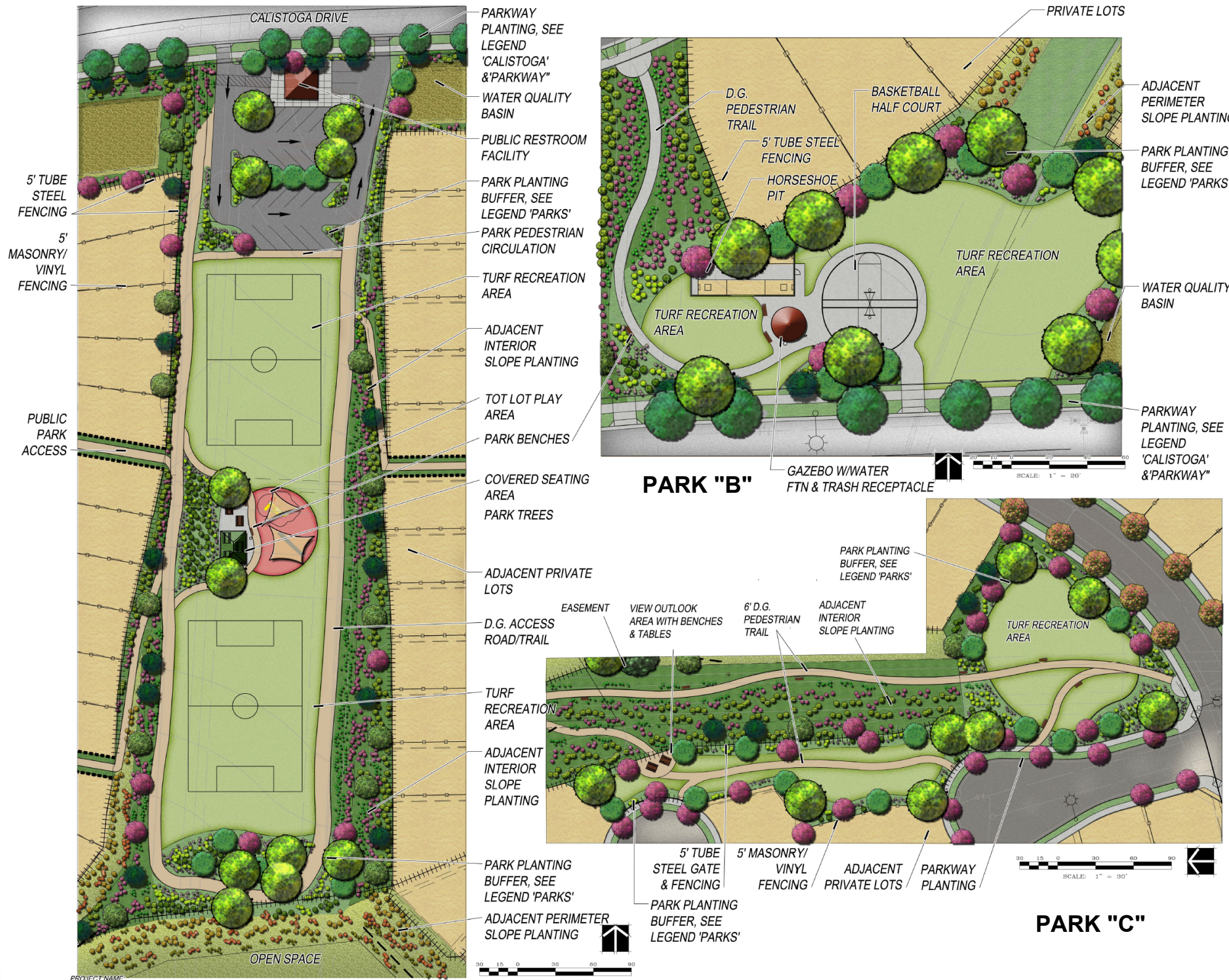

PLANTING CONCEPT LEGEND				
TREES				
SYM	BOTANICAL NAME	COMMON NAME	SIZE	MULGOLS
<b>CALISTOGA DRIVE</b>				
[Symbol]	Pinus ELDERICA	AFSHAN FINE	24" BOX	
<b>INTERIOR STREETS</b>				
[Symbol]	PODOPARPUS BRACILIOR	FERN FINE	24" BOX	
[Symbol]	ARBUTUS UNEDA 'MARINA'	MARINA STRAWBERRY TREE	24" BOX	
[Symbol]	CINNAMOMUM CAMPHORA	CAMPHOR TREE	24" BOX	
[Symbol]	LASERSTROMIA FAURIEI X INDICA	GRAPE MYRTLE	24" BOX	
[Symbol]	LOPHOSTEMON CONFERTUS	BRISBANE BOX	24" BOX	
[Symbol]	OLEA EUROPAEA	FRUITLESS OLIVE	24" BOX	
<b>PARKS</b>				
[Symbol]	LASERSTROMIA FAURIEI X INDICA (STANDARD)	GRAPE MYRTLE	24" BOX	
[Symbol]	OLEA EUROPAEA	FRUITLESS OLIVE	24" BOX	
[Symbol]	PLATANUS RACEMOSA	CALIFORNIA SYCAMORE	24" BOX	
<b>PERIMETER SLOPES (outside brush management)</b>				
[Symbol]	QUERCUS AGRIFOLIA	COAST LIVE OAK	15 GAL	
[Symbol]	PLATANUS RACEMOSA	CALIFORNIA SYCAMORE	15 GAL	
<b>INTERIOR SLOPES</b>				
[Symbol]	LASERSTROMIA FAURIEI X INDICA (MULTI-TRUNK)	GRAPE MYRTLE	24" BOX	
[Symbol]	PINUS ELDERICA	AFSHAN FINE	24" BOX	
[Symbol]	RHUS LANCEA	AFRICAN SUMAC	24" BOX	
<b>SHRUBS - CALISTOGA DRIVE AND PARKS</b>				
SYM	BOTANICAL NAME	COMMON NAME	SIZE	MULGOLS
<b>PARKWAY</b>				
[Symbol]	CAREX DIVULSA	BERKELEY SEDGE	1 GAL	
<b>BACK OF WALK AND ADJACENT SLOPES</b>				
[Symbol]	ANNISOZANTHOS SP	KANSAS COYOTE PAW	5 GAL	
[Symbol]	BACCHARIS PILULARIS TWIN PEAKS	DWARF COYOTE BRUSH	1 GAL	
[Symbol]	DISTIS BICOLOR	FORTNIGHT LILY	1 GAL	
[Symbol]	ECHINUM FASTUOSUM	ECHINUM	5 GAL	
[Symbol]	LIGUSTRUM TEXANUM	TEXAS PRIVET	5 GAL	
[Symbol]	MYOPORUM PARVIFOLIUM	PROSTRATE MYOPORUM	1 GAL	
[Symbol]	RHAPHIOLEPIS 'CLARA'	WHITE INDIA HAWTHORN	5 GAL	
[Symbol]	ROSA 'ICEBERG'	ICEBERG ROSE	5 GAL	
[Symbol]	TRACHELOSPERMUM JASMONOIDES	STAR JASMINE	1 GAL	
<b>SHRUBS (PERIMETER BRUSH MANAGEMENT SLOPES AND ADJACENT TO OPEN SPACE)</b>				
SYM	BOTANICAL NAME	COMMON NAME	SIZE	DETAIL
[Symbol]	ACACIA REDOLENS	DESERT CARPET	1 GAL	
[Symbol]	BACCHARIS P. X GONSANSUNEA	CHAPARRAL BROOM	1 GAL	
[Symbol]	HETEROMELES ARBUTIFOLIA	TOYON	1 GAL	
[Symbol]	RHUS INTEGRIFOLIA	LEMONADE BERRY	1 GAL	
[Symbol]	SALVIA SONMENSIS	CREEPING SAGE	1 GAL	
<b>SHRUBS (WATER QUALITY BASINS)</b>				
SYM	BOTANICAL NAME	COMMON NAME	SIZE	DETAIL
[Symbol]	CAREX DIVULSA	BERKELEY SEDGE	1 GAL	
[Symbol]	CAREX PRAEGRAGILIS	WESTERN MEADOW SEDGE	1 GAL	
[Symbol]	MUHLENBERGIA CAPILLARIS	PINK MUHLY	1 GAL	
<b>VINES - CALISTOGA DRIVE AND PARKS</b>				
SYM	BOTANICAL NAME	COMMON NAME	SIZE	DETAIL
NS	JASMINUM POLYANTHUM	PINK JASMINE	15 GAL	
	GLYSTOMA CALLESTEGODES	LAVENDER TRUMPET VINE	15 GAL	
<b>TURF - ACTIVE USE AREAS OF PARKS</b>				
[Symbol]	MARATHON II		600	



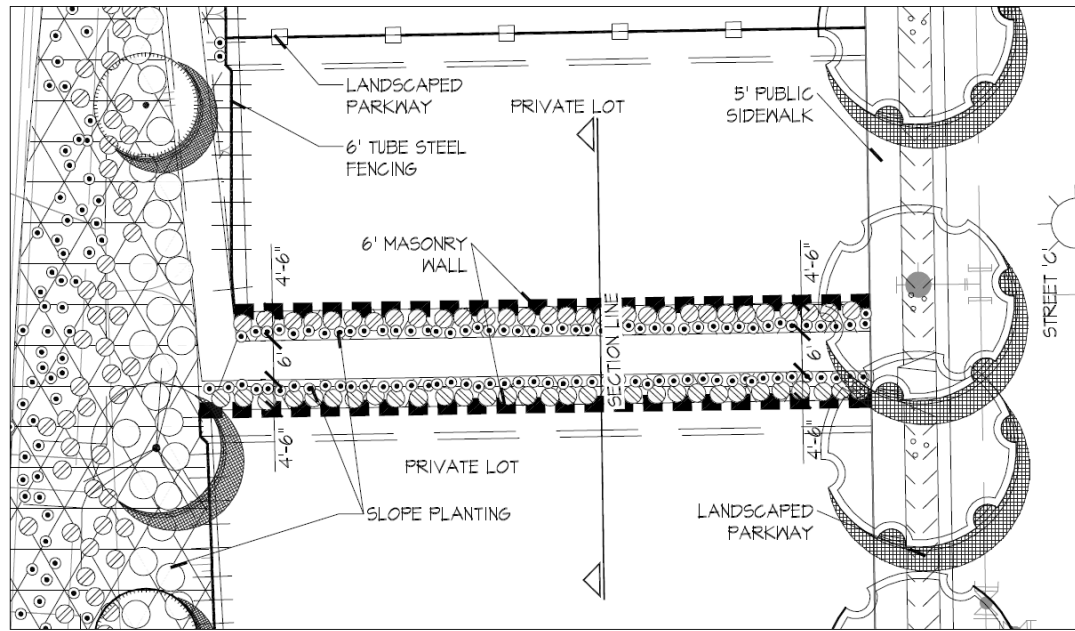

ACCESS 1

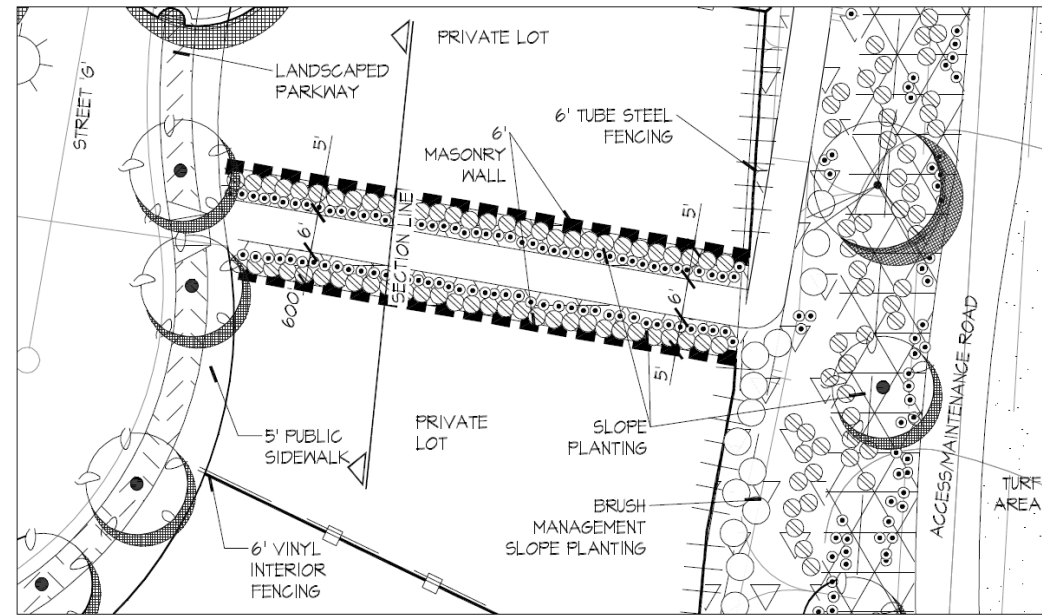

ACCESS 2

KEY MAP

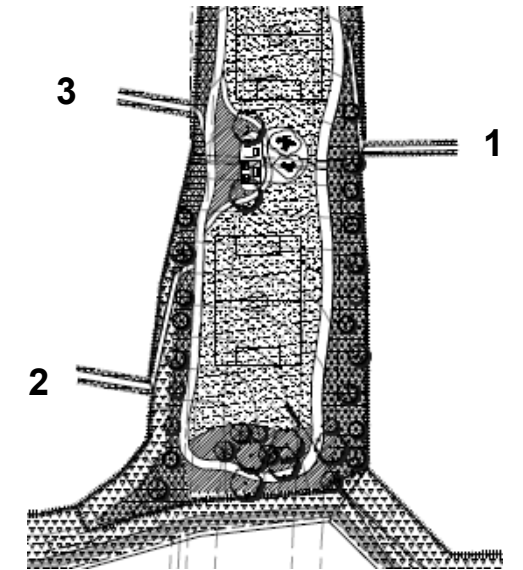

See Figure IV-41 for full view

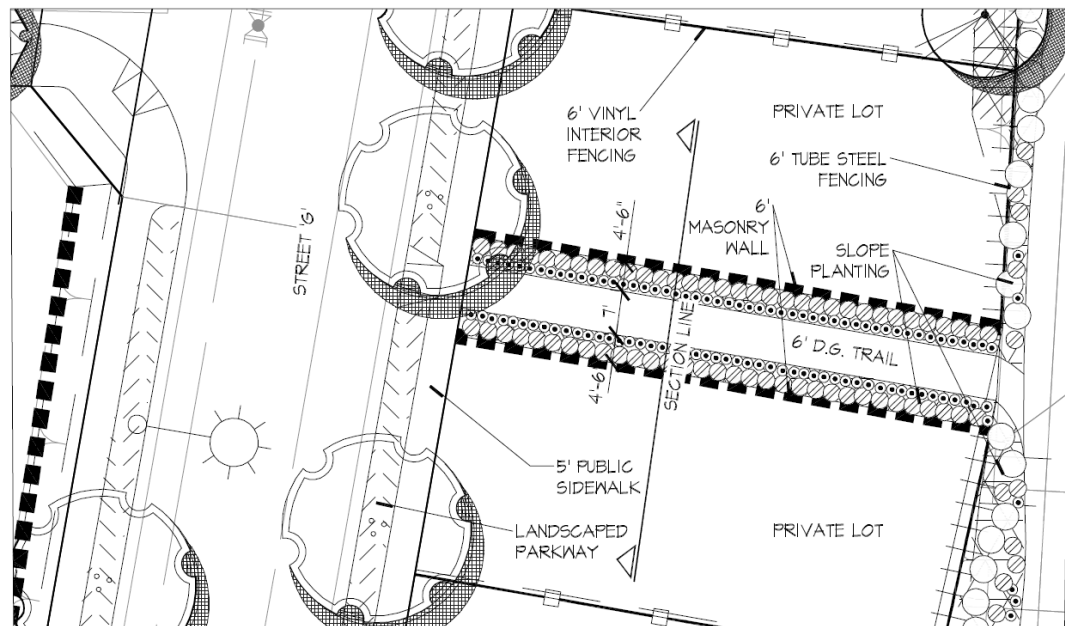

ACCESS 3

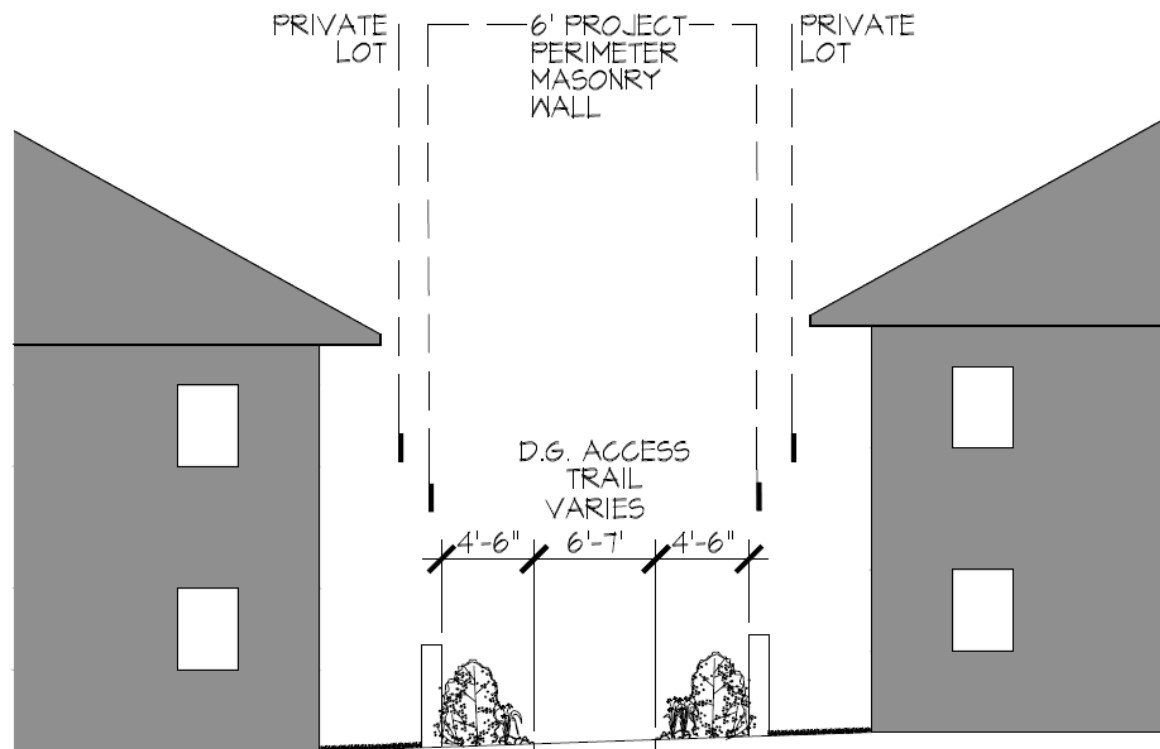

TYPICAL

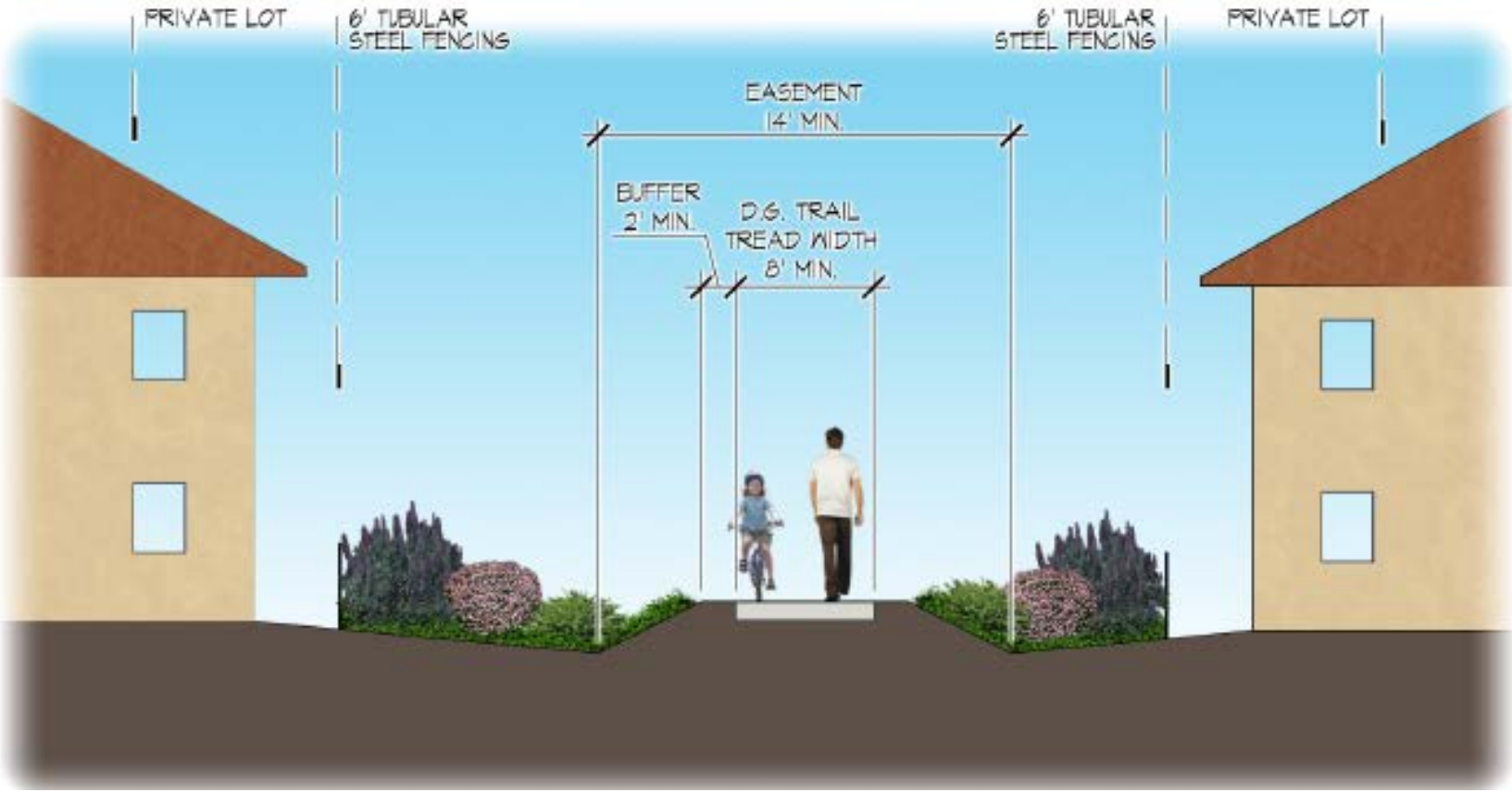
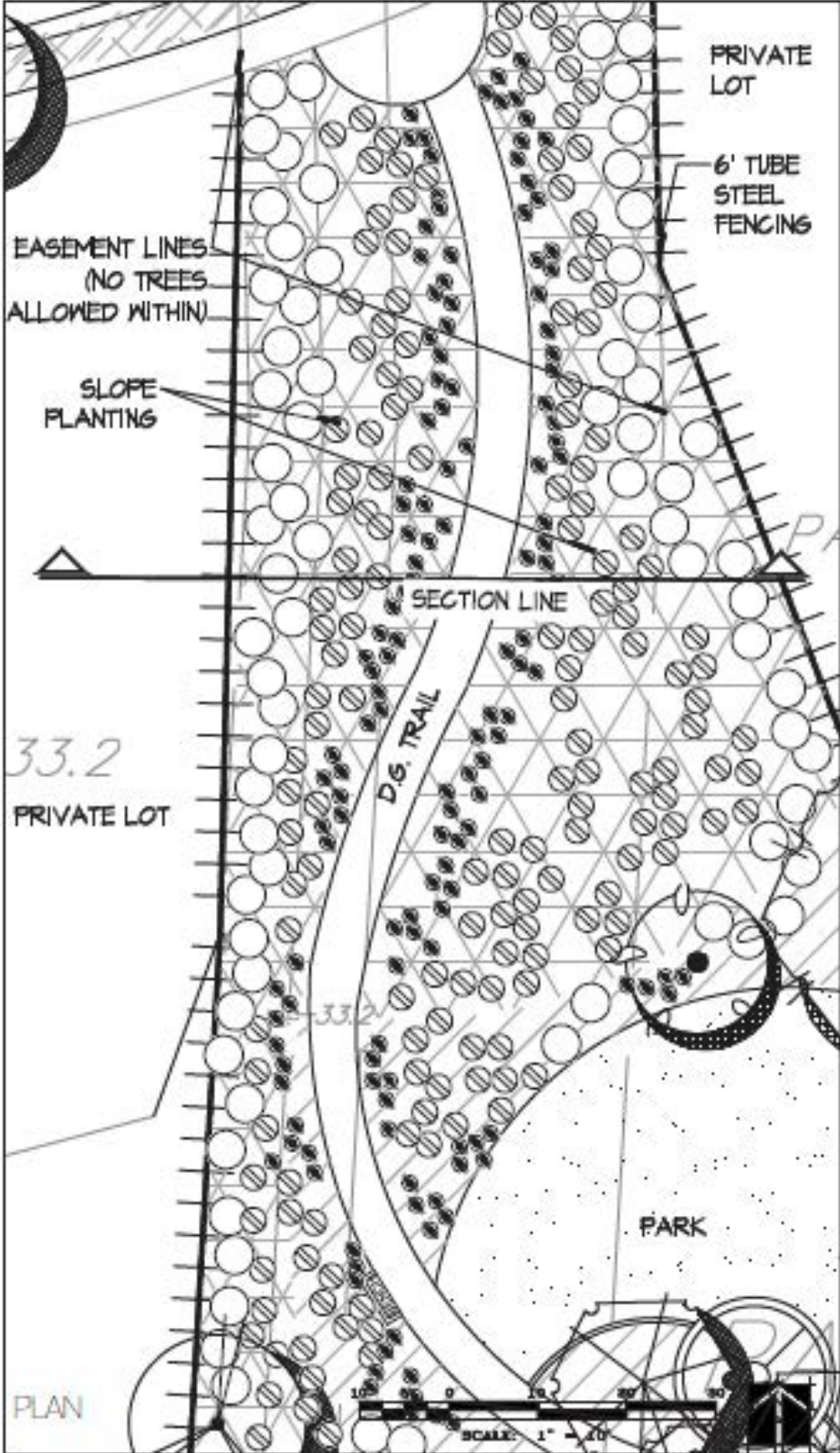





RESIDENTIAL TRAIL LIGHTING FIXTURES - FIGURE IV-81

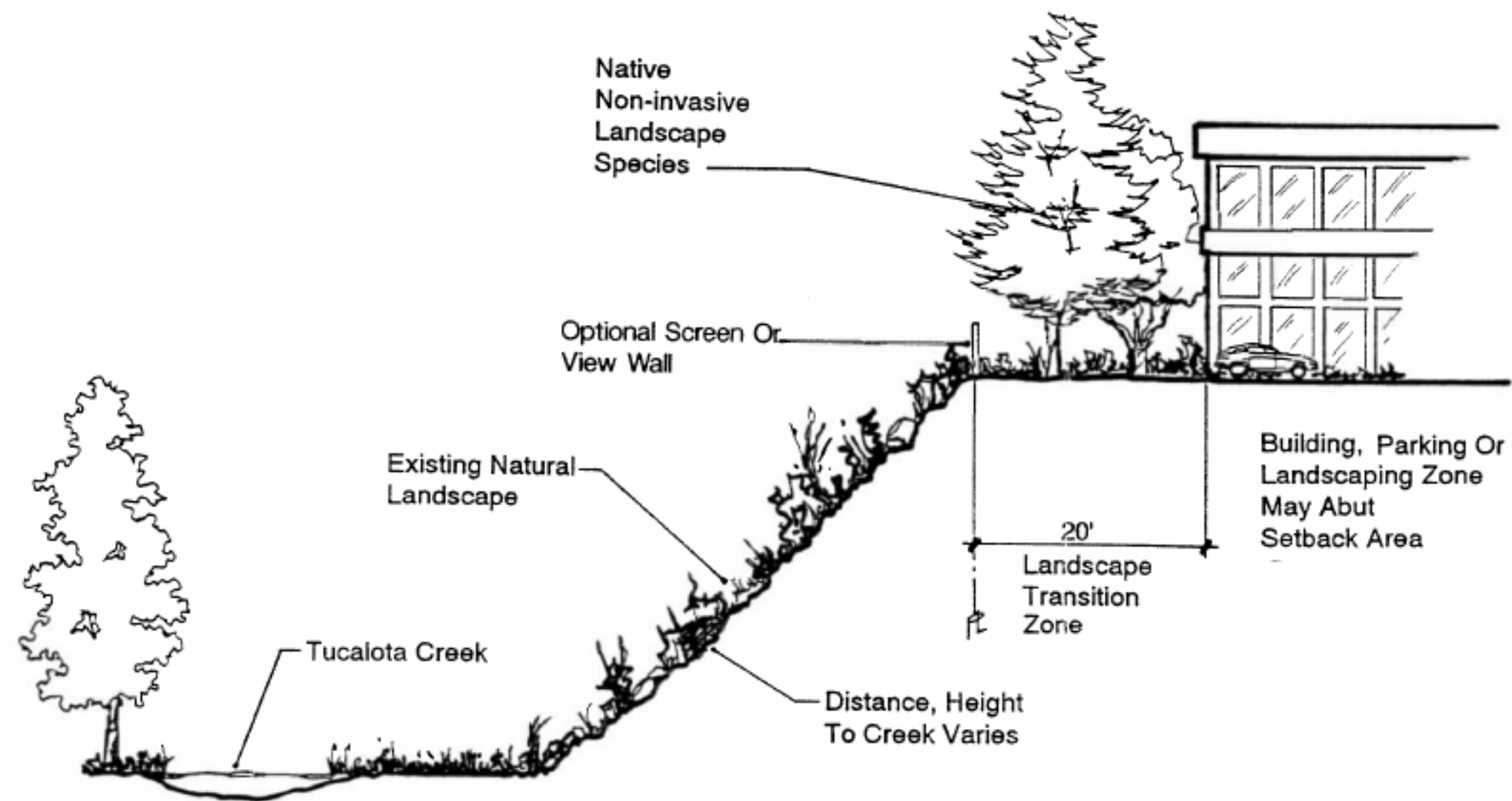



- Wall and Pilaster to be Covered in Medium Stucco Finish
- Tubular Steel Inserts and Supports

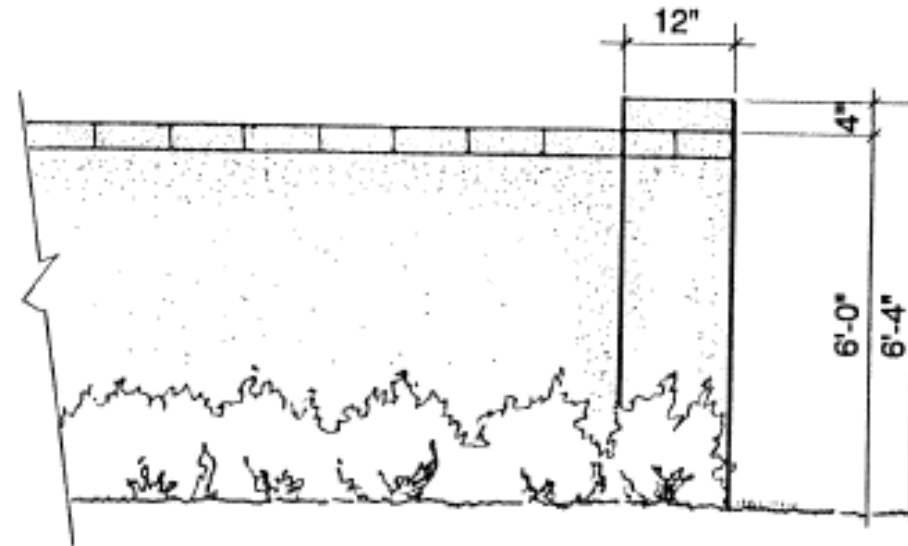



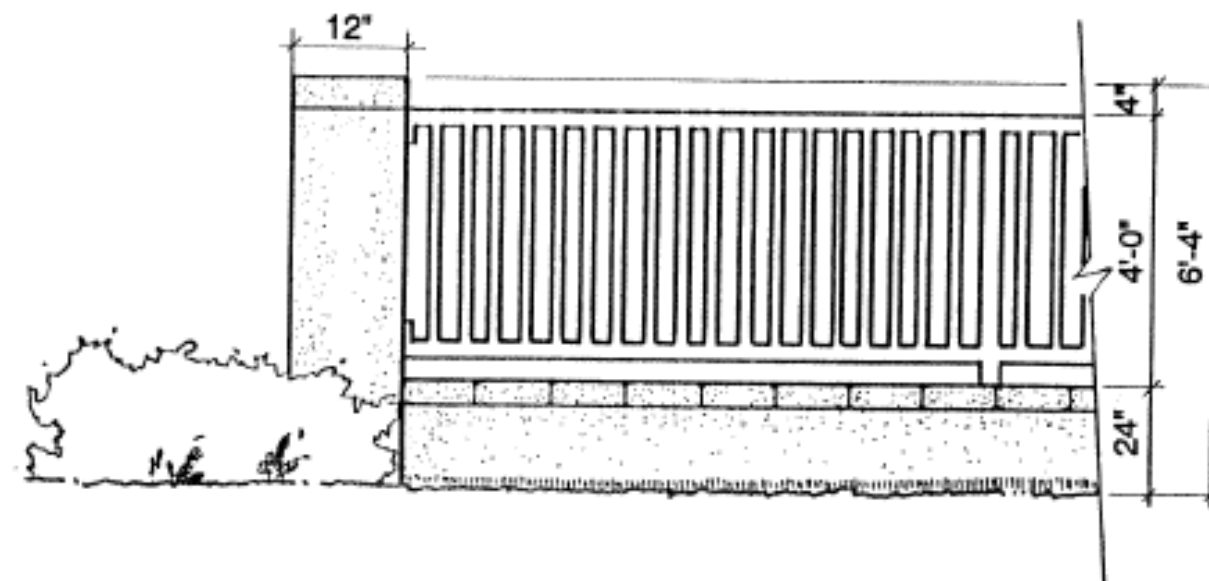

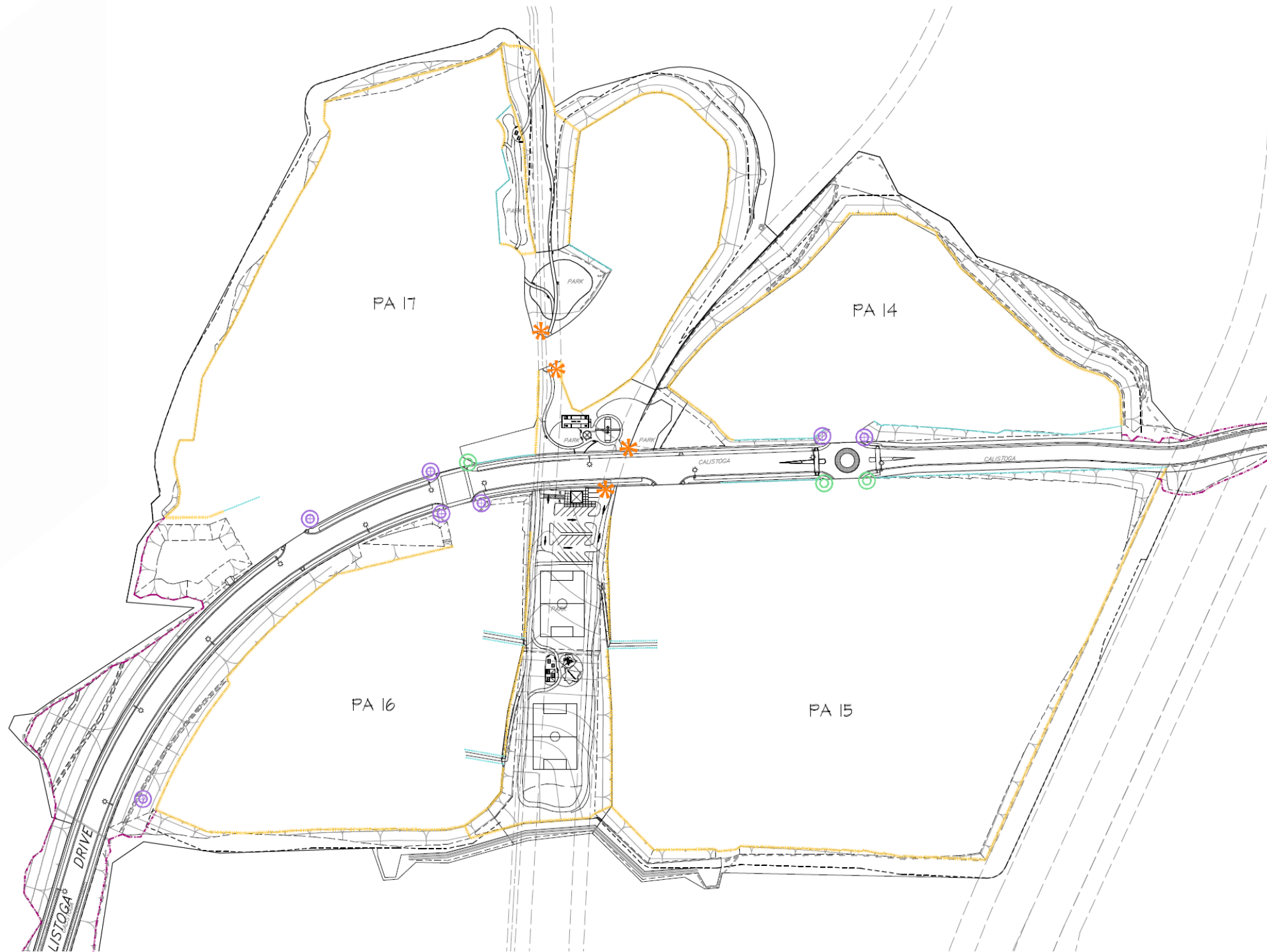

Privacy /Security Wall



View Wall



**LEGEND**

-  6' MASONRY WALL
-  6' TUBULAR STEEL FENCING
-  CHAINLINK ANIMAL CROSSING FENCING
-  FREE STANDING ENTRY MONUMENT
-  NON STAND-ALONE ENTRY MONUMENT
-  TRAILHEAD/PARK MONUMENTS





Masonry Wall Examples



Tubular Steel Example



Vinyl Fencing Example















# Section IV: Landscape Design Guidelines



PLANTING CONCEPT LEGEND				
TREES				
SYM.	BOTANICAL NAME	COMMON NAME	SIZE	MULCOLS
<b>CALISTOGA DRIVE</b>				
	PINUS ELDERICA	AFGHAN PINE	24" BOX	
	PODOCARPUS GRACILIOR	FERN FINE	24" BOX	
<b>INTERIOR STREETS</b>				
	ARBUTUS UNEDO 'MARINA'	MARINA STRAWBERRY TREE	24" BOX	
	GINNAMOMUM CAMPHORA	CAMPHOR TREE	24" BOX	
	LAGERSTROMIA FAURIEI X INDICA	GRAPE MYRTLE	24" BOX	
	LOPHOSTEMON CONFERTUS	BRISBANE BOX	24" BOX	
	OLEA EUROPAEA	FRUITLESS OLIVE	24" BOX	
<b>PARKS</b>				
	LAGERSTROMIA FAURIEI X INDICA (STANDARD)	GRAPE MYRTLE	24" BOX	
	OLEA EUROPAEA	FRUITLESS OLIVE	24" BOX	
	PLATANUS RACEMOSA	CALIFORNIA SYCAMORE	24" BOX	
<b>PERIMETER SLOPES (outside brush management)</b>				
	QUERCUS AGRIFOLIA	COAST LIVE OAK	15 GAL.	
	PLATANUS RACEMOSA	CALIFORNIA SYCAMORE	15 GAL.	
<b>INTERIOR SLOPES</b>				
	LAGERSTROMIA FAURIEI X INDICA (MULTI-TRUNK)	GRAPE MYRTLE	24" BOX	
	PINUS ELDERICA	AFGHAN PINE	24" BOX	
	RHUS LANCEA	AFRICAN SUMAC	24" BOX	

SHRUBS (WATER QUALITY BASINS)				
SYM.	BOTANICAL NAME	COMMON NAME	SIZE	DETAIL
	CAREX DIVULSA	BERKELEY SEDGE	1 GAL.	
	CAREX PRAEGRACILIS	WESTERN MEADOW SEDGE	1 GAL.	
	MUHLENBERGIA CAPILLARIS	PINK MUHLY	1 GAL.	
VINES - CALISTOGA DRIVE AND PARKS				
SYM.	BOTANICAL NAME	COMMON NAME	SIZE	DETAIL
NS	JASMINUM POLYANTHUM	PINK JASMINE	15 GAL.	
	CLYSTOMA CALLESTEGIODES	LAVENDAR TRUMPET VINE	15 GAL.	
TURF - ACTIVE USE AREAS OF PARKS				
	MARATHON II		SOD	

SHRUBS - CALISTOGA DRIVE AND PARKS PARKWAY				
SYM.	BOTANICAL NAME	COMMON NAME	SIZE	MULCOLS
	CAREX DIVULSA	BERKELEY SEDGE	1 GAL.	
<b>BACK OF WALK AND ADJACENT SLOPES</b>				
	ANNIGOZANTHOS SP.	KANGAROO PAW	5 GAL.	
	BACCHARIS PILULARIS 'TWIN PEAKS'	DWARF COYOTE BRUSH	1 GAL.	
	DIETES BICOLOR	FORTNIGHT LILY	1 GAL.	
	ECHIUM FASTUOSUM	ECHIUM	5 GAL.	
	LIGUSTRUM TEXANUM	TEXAS PRIVET	5 GAL.	
	MYOPORUM PARVIFOLIUM	PROSTRATE MYOPORUM	1 GAL.	
	RHAPHIOLEPIS I. 'CLARA'	WHITE INDIA HAWTHORN	5 GAL.	
	ROSA 'ICEBERG'	ICEBERG ROSE	5 GAL.	
	TRACHELOSPERMUM JASMONOIDES	STAR JASMINE	1 GAL.	
SHRUBS (PERIMETER BRUSH MANAGEMENT SLOPES AND ADJACENT TO OPEN SPACE)				
SYM.	BOTANICAL NAME	COMMON NAME	SIZE	DETAIL
	ACACIA REDOLENS 'DESERT CARPET'	DESERT CARPET	1 GAL.	
	BACCHARIS P. X CONSANGUINEA	CHAFARRAL BROOM	1 GAL.	
	HETEROMELES ARBUTIFOLIA	TOYON	1 GAL.	
	RHUS INTEGRIFOLIA	LEMONADE BERRY	1 GAL.	
	SALVIA SONMENSIS	CREeping SAGE	1 GAL.	

