



BERMUDA DUNES
california

LOGO STYLE GUIDE

JANUARY 2009

TABLE of CONTENTS

TABLE of CONTENTS.....	1
STYLE GUIDE OVERVIEW	3
THE BERMUDA DUNES LOGO	4
THE BERMUDA DUNES MAIN LOGO	5
BERMUDA DUNES BLACK & WHITE LOGO VARIATIONS.....	6
BERMUDA DUNES GRAYSCALE LOGO VARIATIONS	7
BERMUDA DUNES TYPEFACES	8
THE BERMUDA DUNES COLOR PALETTE	9
LOGO USEAGE APPLICATIONS	10
LOGO USEAGE APPLICATIONS STATIONARY	12
LOGO USEAGE APPLICATIONS LOGO PLACEMENT.....	13
LOGO USEAGE APPLICATIONS DATA SHEETS, FLYERS, ETC.....	14
LOGO USEAGE APPLICATIONS DATA SHEETS, FLYERS, ETC.....	15
LOGO USEAGE APPLICATIONS ENVIRONMENTAL GRAPHICS.....	16
LOGO USEAGE APPLICATIONS ENVIRONMENTAL GRAPHICS.....	18
LOGO USEAGE APPLICATIONS ENVIRONMENTAL GRAPHICS.....	19
LEGAL NOTICES	20

January 2009

Page Intentionally Blank



STYLE GUIDE OVERVIEW

Every day, the Bermuda Dunes Logo will be noticed on communication material ranging from stationary to signage. Each impression represents the community of Bermuda Dunes and the County of Riverside. The logo and style guidelines unify communications and help them make a clear, strong, consistent message.

Each communication, through its content and presentation, provides information about the Bermuda Dunes image. Direct information is given through what is stated; indirect information is given through the clarity, tone, style, and professionalism with which the information is presented. The result of this dedication to excellence within the marketing communications will only lead to strengthening the image and character of Bermuda Dunes.

THE BERMUDA DUNES LOGO

The Bermuda Dunes Logo has a 6 color CMYK design treatment. The logo is designed to be reproduced primarily in CMYK*/color format.

However, PMS (Pantone Matching System) equivalents for these CMYK colors are supplied for the purposes of ensuring consistency of color reproduction

Ideally the logo will be used on a uniformly colored and patterned background for maximum impact and clarity. The logo will have a minimum of 1/3 X-Height white space around it.

*Abbreviation for cyan, magenta, yellow and key (black), the 4 process colors, which combined together in varying proportions can be made to produce the full colour spectrum.

In order to maintain legibility of the Bermuda Dunes Logo, the minimum height dimension is 1/2", 1.28 centimeters, 3.0 picas, or 36 points on letterhead and similar printed materials.

Ideally the logo will be used on a white background on letterhead and similar printed materials for maximum impact and clarity. The logo will have a minimum of 1/4 X-Height white space around it.

When used on signage, walls and other elements of the streetscape, the background should be a uniformly colored and patterned background.

Note: Do not attempt to construct this logo design. Electronic files in PDF format will be provided.



THE BERMUDA DUNES MAIN LOGO

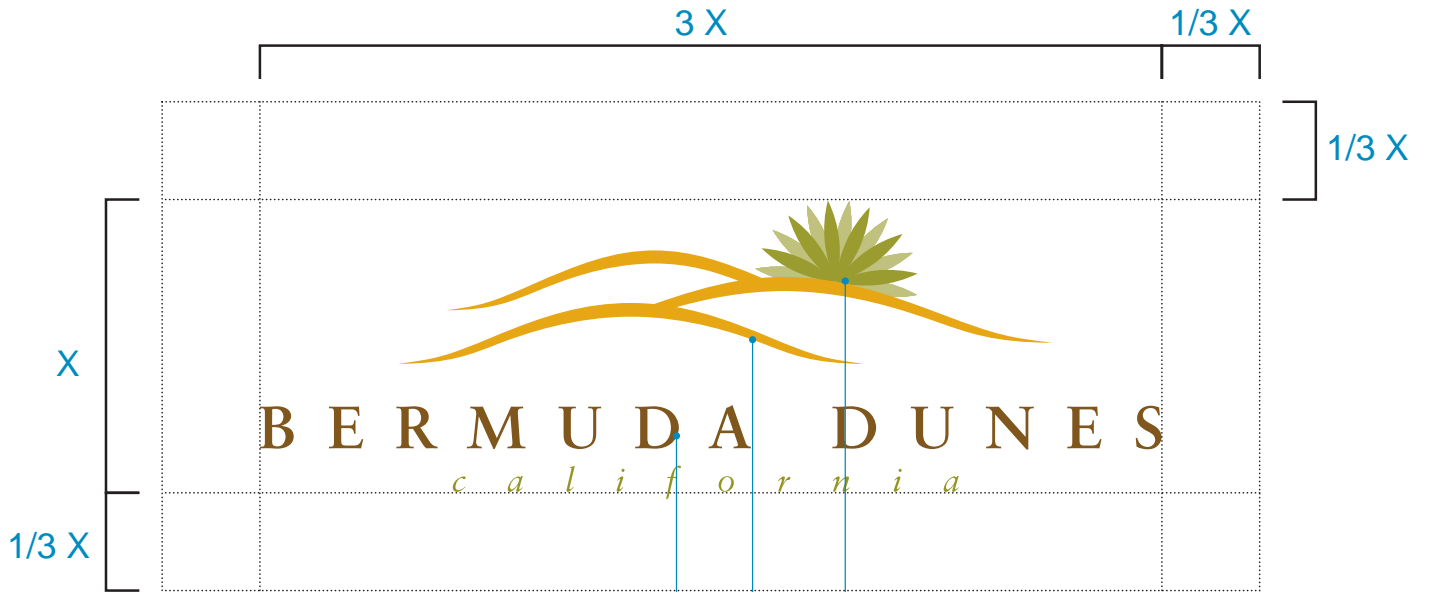

PANTONE 463

CMYK 30C.56M.100Y.37K
RGB 117R.87G.37B
HEX 755725



PANTONE 131

CMYK 0C.M32.100Y.9K
RGB 213R.164G.45B
HEX d5a42d



PANTONE 582

CMYK 13C.0M.100Y.46K
RGB 138R.140G.36B
HEX 8a8c24

BERMUDA DUNES BLACK & WHITE LOGO VARIATIONS



ONE COLOR (MONOCHROMATIC)

For applications where only one color is permitted. White areas/background color indicates no ink.



Example of monochromatic logo on a colored background.



Example of monochromatic logo on a white background.

BERMUDA DUNES GRAYSCALE LOGO VARIATIONS



GRAYSCALE

For better legibility and clarity please use the grayscale version of the logo depending on the nature of the background.



Example of grayscale version of logo on colored background.



Example of grayscale version of logo on white background.

BERMUDA DUNES TYPEFACES

Savoy is the preferred font to be used in conjunction with the Bermuda Dunes logo. This typeface is recommended for display text (headlines) and body copy accompanying the logo.

Savoy

A B C D E F G H I J K L M N O P Q R S T U V W X Y Z
a b c d e f g h i j k l m n o p q r s t u v w x y z

Savoy Bold

A B C D E F G H I J K L M N O P Q R S T U V W X Y Z
a b c d e f g h i j k l m n o p q r s t u v w x y z

Savoy Italic

A B C D E F G H I J K L M N O P Q R S T U V W X Y Z
a b c d e f g h i j k l m n o p q r s t u v w x y z

Savoy Small Caps

A B C D E F G H I J K L M N O P Q R S T U V W X Y Z
A B C D E F G H I J K L M N O P Q R S T U V W X Y Z

Savoy Small Caps Bold

A B C D E F G H I J K L M N O P Q R S T U V W X Y Z
A B C D E F G H I J K L M N O P Q R S T U V W X Y Z

THE BERMUDA DUNES COLOR PALETTE

PANTONE 463

CMYK 30C.56M.100Y.37K

RGB 117R.87G.37B

HEX 755725

PANTONE 582

CMYK 13C.0M.100Y.46K

RGB 138R.140G.36B

HEX 8a8c24

PANTONE 131

CMYK 0C.M32.100Y.9K

RGB 213R.164G.45B

HEX d5a42d

LOGO USEAGE APPLICATIONS



BERMUDA DUNES OBELISK MONUMENT

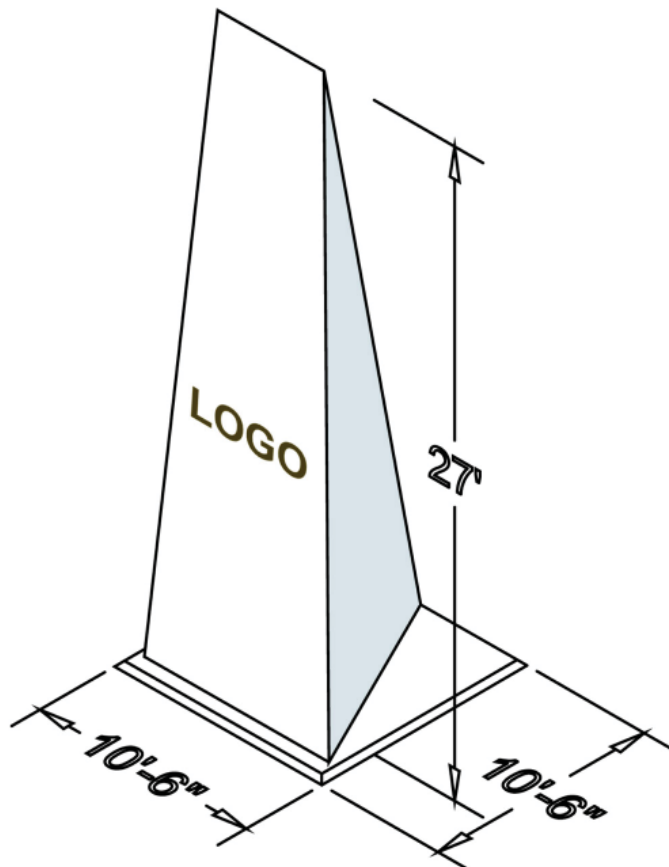
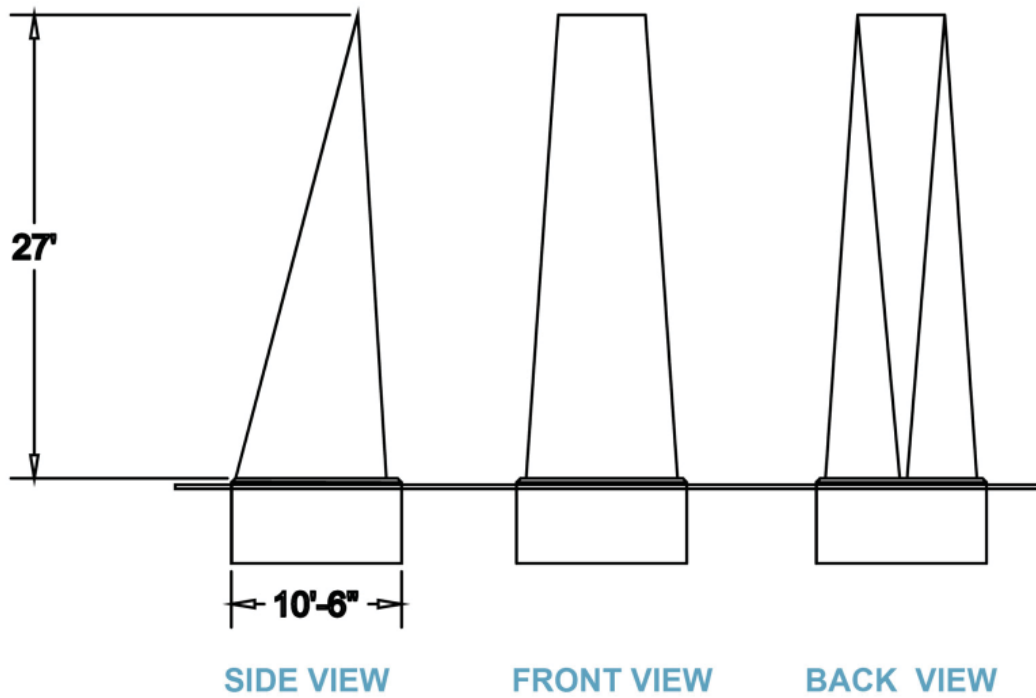

3D VIEW

BERMUDA DUNES OBELISK MONUMENT DIMENSIONS

Note: It may be necessary to adjust dimensions to accommodate site conditions or engineering. Keep proportions the same as shown.

LOGO USAGE APPLICATIONS | STATIONARY

The following information serves as a guide to creating new designs and layouts. A hierarchy of information has been established, through the use of character styles, sizes and secondary graphics. This must be carried through in all future communications to maintain consistency.

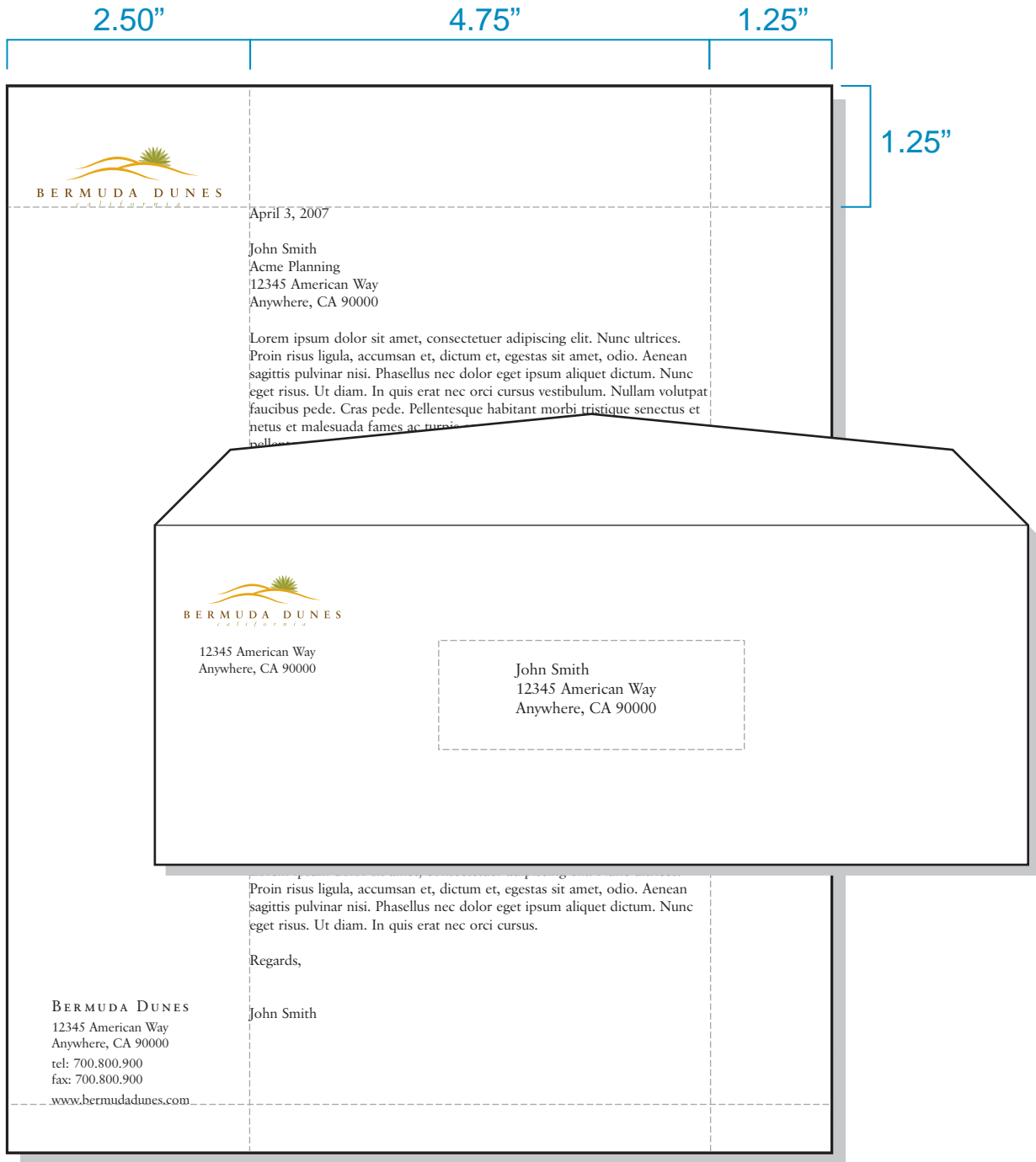

LOGO USAGE APPLICATIONS | LOGO PLACEMENT

For most applications the optimum placement for the Bermuda Dunes Logo is the top left corner, or right corner of the layout with 1x-height white space around it, or a reasonable margin.

If required, the logo placements shown below are also acceptable. However for signage and large applications the logo must be placed at least 3 feet from the ground.

The size and location of the logo must be in proportion to the required size of signage text and form.

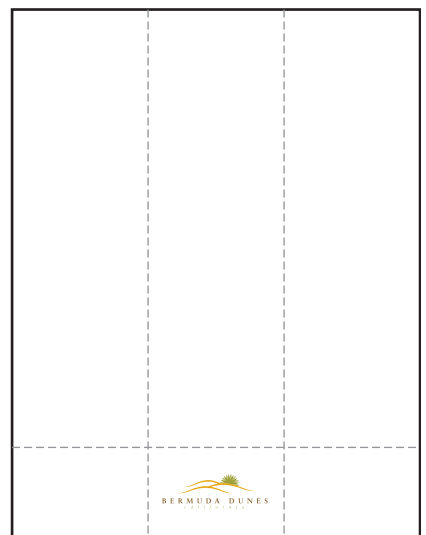
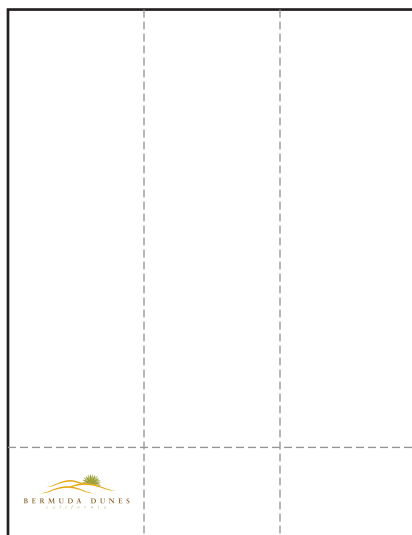
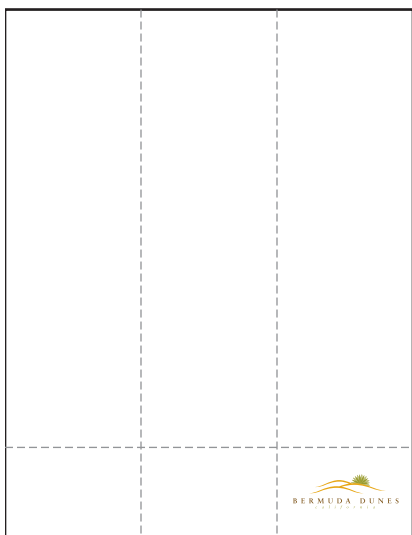
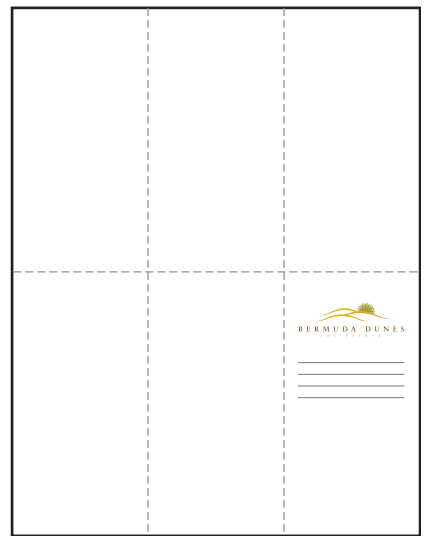
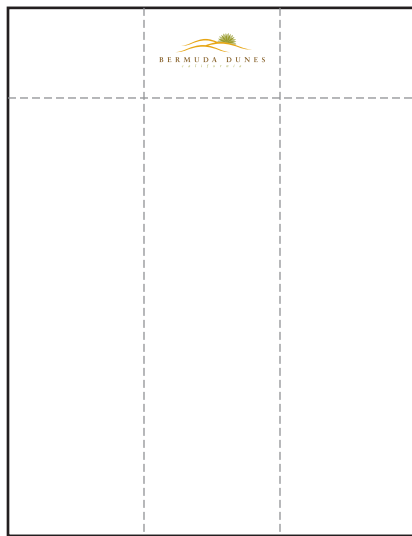
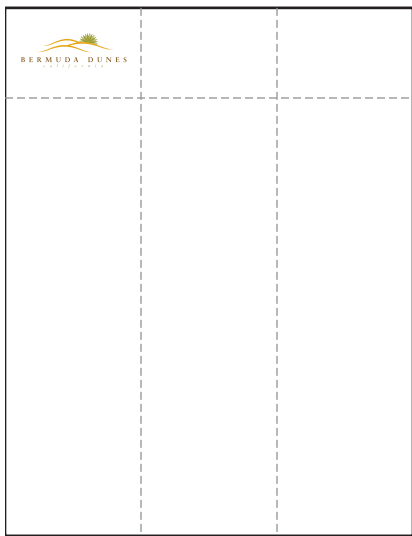

LOGO USAGE APPLICATIONS | DATA SHEETS, FLYERS, ETC.



SHEET TITLE | SECONDARY INFORMATION

Cras congue orci. Etiam semper risus at neque. Donec porttitor laoreet quam. Morbi at enim non elit aliquam aliquam.

Cras congue orci. Etiam semper risus at neque. Donec porttitor laoreet elit aliquam aliquam.

Morbi at enim non elit aliquam aliquam. Sed tincidunt eros ac nulla consectetur adipiscing elit.

Etiam cursus. Lorem ipsum dolor sit amet, consectetur dolor sit amet adipiscing elit.

Pellentesque habitant morbi tristique senectus et netus et malesuada fames ac turpis egestas.

Cras congue orci. Etiam semper risus at neque. Donec porttitor laoreet elit aliquam aliquam.



Vivamus porta nonummy lectus. Suspendisse eget eros in odio mollis elementum. Duis magna mi, pharetra non, pellentesque et, pulvinar quis, lacus. Mauris lacus massa, facilisis lacinia, placerat quis, luctus sed, nulla. Quisque venenatis. Proin in sem vitae turpis tempor aliquam.

Lorem ipsum dolor sit amet, consectetur adipiscing elit. Nunc ultrices. Proin risus ligula, accumsan et, dictum et, egestas sit amet, odio. Aenean sagittis pulvinar nisi. Phasellus nec dolor eget ipsum aliquet dictum. Nunc eget risus. Ut diam. In quis erat nec orci cursus vestibulum. Nullam volutpat faucibus pede. Cras pede. Pellentesque habitant morbi tristique senectus et netus et malesuada fames ac turpis egestas. Aliquam erat volutpat. Vivamus pellentesque tortor vel quam. Nam nisl. Mauris a arcu. Fusce eget quam in pede lacinia tincidunt. Nunc ligula. Nullam congue.

Aliquam erat volutpat. Vivamus pellentesque tortor vel quam. Nam nisl. Mauris a arcu. Fusce eget quam in pede lacinia tincidunt. Nunc ligula. Nullam congue.

Cras congue orci. Etiam semper risus at neque. Donec porttitor laoreet quam. Morbi at enim non elit aliquam aliquam. Sed tincidunt eros ac nulla. Etiam cursus. Lorem ipsum dolor sit amet, consectetur adipiscing elit. Sed posuere pede cursus libero. iaculis nisl in arcu. Aliquam ac pede. Vestibulum quis massa et libero tincidunt sollicitudin. Etiam nibh. Praesent augue turpis, commodo in, sagittis sed, ultrices eu, erat. Cras vestibulum nibh non sem.

Cras congue orci. Etiam semper risus at neque. Donec porttitor laoreet quam. Morbi at enim non elit aliquam aliquam. Sed tincidunt eros ac nulla. Etiam cursus. Lorem ipsum dolor sit amet, consectetur adipiscing elit. Pellentesque habitant morbi tristique senectus et netus et malesuada fames ac turpis egestas.

BERMUDA DUNES | 12345 American Way | Anywhere Town, California 90000

Section 1
Application Logo
Headline

Section 2
Key Feature/Message
Color: Pantone 131 U
Related Imagery

Section 3
Introduction
Body Copy

Section 4
Footer information

LOGO USAGE APPLICATIONS | DATA SHEETS, FLYERS, ETC.



SHEET TITLE | SECONDARY INFORMATION

Cras congue orci. Etiam semper risus at neque. Donec porttitor laoreet quam. Morbi at enim non elit aliquam aliquam.

Cras congue orci. Etiam semper risus at neque. Donec porttitor laoreet elit aliquam aliquam.

Morbi at enim non elit aliquam aliquam. Sed tincidunt eros ac nulla consectetur adipiscing elit.

Etiam cursus. Lorem ipsum dolor sit amet, consectetur dolor sit amet adipiscing elit.

Pellentesque habitant morbi tristique senectus et netus et malesuada fames ac turpis egestas.

Cras congue orci. Etiam semper risus at neque. Donec porttitor laoreet elit aliquam aliquam.



Vivamus porta nonummy lectus. Suspendisse eget eros in odio mollis elementum. Duis magna mi, pharetra non, pellentesque et, pulvinar quis, lacus. Mauris lacus massa, facilisis lacinia, placerat quis, luctus sed, nulla. Quisque venenatis. Proin in sem vitae turpis tempor aliquam.

Lorem ipsum dolor sit amet, consectetur adipiscing elit. Nunc ultrices. Proin risus ligula, accumsan et, dictum et, egestas sit amet, odio. Aenean sagittis pulvinar nisi. Phasellus nec dolor eget ipsum aliquet dictum. Nunc eget risus. Ut diam. In quis erat nec orci cursus vestibulum. Nullam volutpat faucibus pede. Cras pede. Pellentesque habitant morbi tristique senectus et netus et malesuada fames ac turpis egestas. Aliquam erat volutpat. Vivamus pellentesque tortor vel quam. Nam nisl. Mauris a arcu. Fusce eget quam in pede lacinia tincidunt. Nunc ligula. Nullam congue.

Aliquam erat volutpat. Vivamus pellentesque tortor vel quam. Nam nisl. Mauris a arcu. Fusce eget quam in pede lacinia tincidunt. Nunc ligula. Nullam congue.

Cras congue orci. Etiam semper risus at neque. Donec porttitor laoreet quam. Morbi at enim non elit aliquam aliquam. Sed tincidunt eros ac nulla. Etiam cursus. Lorem ipsum dolor sit amet, consectetur adipiscing elit. Sed posuere pede cursus libero. iaculis nisl in arcu. Aliquam ac pede. Vestibulum quis massa et libero tincidunt sollicitudin. Etiam nibh. Praesent augue turpis, commodo in, sagittis sed, ultrices eu, erat. Cras vestibulum nibh non sem.

Cras congue orci. Etiam semper risus at neque. Donec porttitor laoreet quam. Morbi at enim non elit aliquam aliquam. Sed tincidunt eros ac nulla. Etiam cursus. Lorem ipsum dolor sit amet, consectetur adipiscing elit. Pellentesque habitant morbi tristique senectus et netus et malesuada fames ac turpis egestas.

BERMUDA DUNES | 12345 American Way | Anywhere Town, California 90000

Section 1
Application Logo
Headline

Section 2
Key Feature/Message
Color: Pantone 463 U
Related Imagery

Section 3
Introduction
Body Copy

Section 4
Footer information

LOGO USEAGE APPLICATIONS | ENVIRONMENTAL GRAPHICS

As is evident by the examples shown below, the logo can be presented and applied to various materials without altering the colors or the main graphic language that makes up the logo. This way the integrity of the logo can be maintained while still portraying the unique Bermuda Dunes brand.



BERMUDA DUNES 10' OBELISK MONUMENT

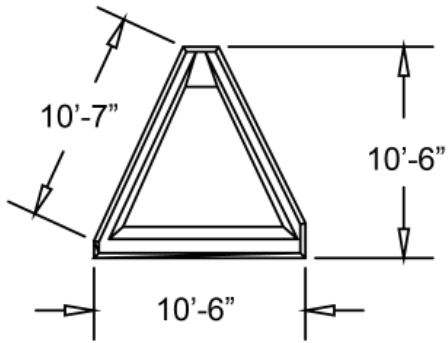

TOP VIEW

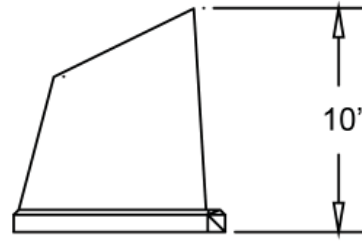

SIDE VIEW

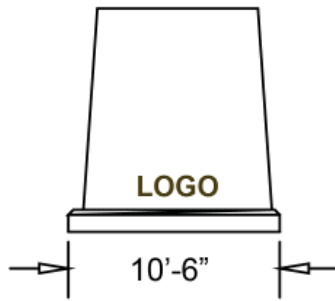

FRONT VIEW

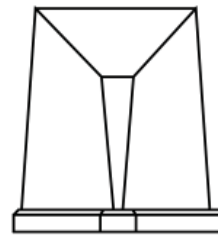

BACK VIEW

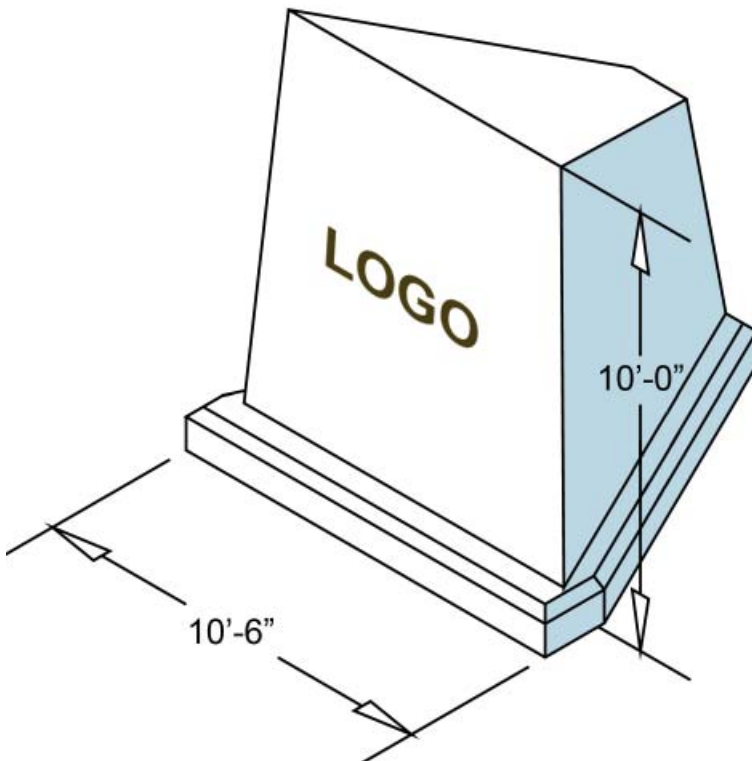

**BERMUDA DUNES 10' OBELISK
MONUMENT DIMENSIONS**

Note: It may be necessary to adjust dimensions to accommodate site conditions or engineering. Keep proportions the same as shown.

LOGO USEAGE APPLICATIONS | ENVIRONMENTAL GRAPHICS



BERMUDA DUNES OBELISK MONUMENT - NIGHT SCENE

LOGO USEAGE APPLICATIONS | ENVIRONMENTAL GRAPHICS



EXAMPLE OF LOGO APPLICATION ON STREET SIGN

LEGAL NOTICES

The County of Riverside is the sole and exclusive owner of the Logo. Any person, company or governmental entity who desires to use the Logo must first obtain Riverside County's prior, express written consent. If consent is given, then any party who uses the Logo agrees that they shall not change or alter the design, colors, or configuration of the Logo in any way, and shall use the logo consistent with the consent given.

Contact:

Riverside County Planning Department
(959) 955-3200
4080 Lemon Street, 9th Floor
Riverside, CA 92502

If not attached to this Style Guide, a scalable electronic file in PDF format will be provided by the County. This file must be used to lay out the logo. Do not attempt to lay out logo in a freehand manner.