



---

# **Glen Ivy Senior Community**

## **TRAFFIC ANALYSIS**

### **COUNTY OF RIVERSIDE**

PREPARED BY:

Aric Evatt, PTP  
aevatt@urbanxroads.com  
(949) 336-5978

Charlene So, PE  
cso@urbanxroads.com  
(949) 660-1994 x222

Connor Paquin, PE  
cpaquin@urbanxroads.com  
(949) 660-1994 x6635

JANUARY 5, 2021

---

*13030-04 TA Report*





## TABLE OF CONTENTS

<b>TABLE OF CONTENTS</b> .....	<b>I</b>
<b>APPENDICES</b> .....	<b>III</b>
<b>LIST OF EXHIBITS</b> .....	<b>V</b>
<b>LIST OF TABLES</b> .....	<b>VII</b>
<b>LIST OF ABBREVIATED TERMS</b> .....	<b>IX</b>
<b>1 INTRODUCTION</b> .....	<b>1</b>
1.1 Summary of Findings.....	1
1.2 Project Overview.....	3
1.3 Analysis Scenarios .....	3
1.4 Study Area.....	5
1.5 Deficiencies .....	7
1.6 Recommendations .....	9
<b>2 METHODOLOGIES</b> .....	<b>17</b>
2.1 Level of Service .....	17
2.2 Intersection Capacity Analysis .....	17
2.3 Traffic Signal Warrant Analysis Methodology.....	19
2.4 Minimum Level of Service (LOS) .....	20
2.5 Deficiency Criteria.....	21
<b>3 AREA CONDITIONS</b> .....	<b>23</b>
3.1 Existing Circulation Network.....	23
3.2 General Plan Circulation Elements.....	23
3.3 Bicycle & Pedestrian Facilities.....	27
3.4 Transit Service .....	27
3.5 Existing Traffic Counts.....	30
3.6 Existing (2020) Intersection Operations Analysis .....	32
3.7 Existing (2020) Traffic Signal Warrants Analysis .....	32
3.8 Recommended Improvements .....	32
<b>4 PROJECTED FUTURE TRAFFIC</b> .....	<b>35</b>
4.1 Project Trip Generation.....	35
4.2 Project Trip Distribution.....	35
4.3 Modal Split .....	39
4.4 Project Trip Assignment .....	39
4.5 Background Traffic .....	39
4.6 Cumulative Development Traffic .....	42
4.7 Near-Term Traffic Conditions.....	42
4.8 Horizon Year (2040) Volume Development.....	47
<b>5 EAP (2023) TRAFFIC CONDITIONS</b> .....	<b>49</b>
5.1 Roadway Improvements .....	49
5.2 EAP (2023) Traffic Volume Forecasts.....	49
5.3 Intersection Operations Analysis .....	49
5.4 Traffic Signal Warrants Analysis.....	49
6.5 Recommended Improvements .....	55
<b>6 EAPC (2023) TRAFFIC CONDITIONS</b> .....	<b>57</b>

6.1 Roadway Improvements ..... 57

6.2 EAPC (2023) Traffic Volume Forecasts ..... 57

6.3 Intersection Operations Analysis ..... 57

6.4 Traffic Signal Warrants Analysis ..... 63

6.5 Deficiencies and Recommended Improvements ..... 63

**7 HORIZON YEAR (2040) TRAFFIC CONDITIONS ..... 65**

7.1 Roadway Improvements ..... 65

7.2 Horizon Year (2040) Without Project Traffic Volume Forecasts ..... 65

7.3 Horizon Year (2040) With Project Traffic Volume Forecasts ..... 65

7.4 Intersection Operations Analysis ..... 69

7.5 Traffic Signal Warrants Analysis ..... 69

7.6 Deficiencies and Recommended Improvements ..... 74

**8 LOCAL AND REGIONAL FUNDING MECHANISMS ..... 77**

8.1 Riverside County Transportation Uniform Mitigation Fee (TUMF) ..... 77

8.2 County of Riverside Development Impact Fee (DIF) Program ..... 77

8.3 Measure A ..... 77

**9 REFERENCES ..... 79**

## **APPENDICES**

- APPENDIX 1.1: APPROVED TRAFFIC STUDY SCOPING AGREEMENT**
- APPENDIX 1.2: SITE ADJACENT QUEUES**
- APPENDIX 3.1: EXISTING TRAFFIC COUNTS – SEPTEMBER 2018 & NOVEMBER 2019**
- APPENDIX 3.2: EXISTING (2020) CONDITIONS INTERSECTION OPERATIONS ANALYSIS WORKSHEETS**
- APPENDIX 3.3: EXISTING (2020) CONDITIONS TRAFFIC SIGNAL WARRANT ANALYSIS WORKSHEETS**
- APPENDIX 4.1: POST-PROCESSING WORKSHEETS**
- APPENDIX 5.1: EAP (2023 – RIRO AT DRIVEWAY 4) CONDITIONS INTERSECTION OPERATIONS ANALYSIS WORKSHEETS**
- APPENDIX 5.2: EAP (2023 – FULL ACCESS AT DRIVEWAY 4) CONDITIONS INTERSECTION OPERATIONS ANALYSIS WORKSHEETS**
- APPENDIX 5.3: EAP (2023) CONDITIONS TRAFFIC SIGNAL WARRANT ANALYSIS WORKSHEETS**
- APPENDIX 6.1: EAPC (2023 – RIRO AT DRIVEWAY 4) CONDITIONS INTERSECTION OPERATIONS ANALYSIS WORKSHEETS**
- APPENDIX 6.2: EAPC (2023 – FULL ACCESS AT DRIVEWAY 4) CONDITIONS INTERSECTION OPERATIONS ANALYSIS WORKSHEETS**
- APPENDIX 6.3: EAPC (2023) CONDITIONS TRAFFIC SIGNAL WARRANT ANALYSIS WORKSHEETS**
- APPENDIX 6.4: EAPC (2023) CONDITIONS INTERSECTION OPERATIONS ANALYSIS WORKSHEETS WITH IMPROVEMENTS**
- APPENDIX 7.1: HORIZON YEAR (2040) WITHOUT PROJECT CONDITIONS INTERSECTION OPERATIONS ANALYSIS WORKSHEETS**
- APPENDIX 7.2: HORIZON YEAR (2040) WITH PROJECT (RIRO AT DRIVEWAY 4) CONDITIONS INTERSECTION OPERATIONS ANALYSIS WORKSHEETS**
- APPENDIX 7.3: HORIZON YEAR (2040) WITH PROJECT (FULL ACCESS AT DRIVEWAY 4) CONDITIONS INTERSECTION OPERATIONS ANALYSIS WORKSHEETS**
- APPENDIX 7.4: HORIZON YEAR (2040) WITH PROJECT CONDITIONS TRAFFIC SIGNAL WARRANT ANALYSIS WORKSHEETS**
- APPENDIX 7.5: HORIZON YEAR (2040) WITH PROJECT CONDITIONS INTERSECTION OPERATIONS ANALYSIS WORKSHEETS WITH IMPROVEMENTS**

This Page Intentionally Left Blank

**LIST OF EXHIBITS**

EXHIBIT 1-1: PRELIMINARY SITE PLAN ..... 2

EXHIBIT 1-2: LOCATION MAP..... 6

EXHIBIT 1-3: SUMMARY OF DEFICIENT INTERSECTIONS BY ANALYSIS SCENARIO ..... 8

EXHIBIT 1-4: SITE ADJACENT ROADWAY AND SITE ACCESS RECOMMENDATIONS ..... 10

EXHIBIT 1-5: TRILOGY PARKWAY AND TEMESCAL CANYON ROAD CONCEPT STRIPING ..... 11

EXHIBIT 3-1: EXISTING NUMBER OF THROUGH LANES AND INTERSECTION CONTROLS ..... 24

EXHIBIT 3-2: COUNTY OF RIVERSIDE GENERAL PLAN CIRCULATION ELEMENT ..... 25

EXHIBIT 3-3: COUNTY OF RIVERSIDE GENERAL PLAN ROADWAY CROSS-SECTIONS ..... 26

EXHIBIT 3-4: COUNTY OF RIVERSIDE TRAILS AND BIKEWAY SYSTEM..... 28

EXHIBIT 3-5: EXISTING PEDESTRIAN FACILITIES..... 29

EXHIBIT 3-6: EXISTING (2020) TRAFFIC VOLUMES ..... 31

EXHIBIT 3-7: EXISTING (2020) SUMMARY OF LOS ..... 34

EXHIBIT 4-1: PROJECT (RIRO AT DRIVEWAY 4) TRIP DISTRIBUTION ..... 37

EXHIBIT 4-2: PROJECT (FULL ACCESS AT DRIVEWAY 4) TRIP DISTRIBUTION ..... 38

EXHIBIT 4-3: PROJECT (RIRO AT DRIVEWAY 4) TRAFFIC VOLUMES ..... 40

EXHIBIT 4-4: PROJECT (FULL ACCESS AT DRIVEWAY 4) TRAFFIC VOLUMES ..... 41

EXHIBIT 4-5: CUMULATIVE DEVELOPMENT PROJECTS LOCATION MAP ..... 43

EXHIBIT 4-6: CUMULATIVE DEVELOPMENT TRAFFIC VOLUMES..... 44

EXHIBIT 5-1: EAP (2023 – RIRO AT DRIVEWAY 4) TRAFFIC VOLUMES ..... 50

EXHIBIT 5-2: EAP (2023 – FULL ACCESS AT DRIVEWAY 4) TRAFFIC VOLUMES ..... 51

EXHIBIT 5-3: EAP (2023 – RIRO AT DRIVEWAY 4) SUMMARY OF LOS..... 52

EXHIBIT 5-4: EAP (2023 – FULL ACCESS AT DRIVEWAY 4) SUMMARY OF LOS..... 53

EXHIBIT 6-1: EAPC (2023 – RIRO AT DRIVEWAY 4) TRAFFIC VOLUMES ..... 58

EXHIBIT 6-2: EAPC (2023 – FULL ACCESS AT DRIVEWAY 4) TRAFFIC VOLUMES ..... 59

EXHIBIT 6-3: EAPC (2023 – RIRO AT DRIVEWAY 4) SUMMARY OF LOS..... 60

EXHIBIT 6-4: EAPC (2023 – FULL ACCESS AT DRIVEWAY 4) SUMMARY OF LOS..... 61

EXHIBIT 7-1: HORIZON YEAR (2040) WITHOUT PROJECT TRAFFIC VOLUMES ..... 66

EXHIBIT 7-2: HORIZON YEAR (2040) WITH PROJECT (RIRO AT DRIVEWAY 4) TRAFFIC VOLUMES ..... 67

EXHIBIT 7-3: HORIZON YEAR (2040) WITH PROJECT (FULL ACCESS AT DRIVEWAY 4) TRAFFIC VOLUMES  
..... 68

EXHIBIT 7-4: HORIZON YEAR (2040) WITHOUT PROJECT SUMMARY OF LOS ..... 71

EXHIBIT 7-5: HORIZON YEAR (2040) WITH PROJECT (RIRO AT DRIVEWAY 4) SUMMARY OF LOS ..... 72

EXHIBIT 7-6: HORIZON YEAR (2040) WITH PROJECT (FULL ACCESS AT DRIVEWAY 4) SUMMARY OF LOS  
..... 73

This Page Intentionally Left Blank

**LIST OF TABLES**

**TABLE 1-1: INTERSECTION ANALYSIS LOCATIONS ..... 5**  
**TABLE 1-2: SUMMARY OF IMPROVEMENTS BY ANALYSIS SCENARIO ..... 15**  
**TABLE 2-1: SIGNALIZED INTERSECTION LOS THRESHOLDS..... 18**  
**TABLE 2-2: UNSIGNALIZED INTERSECTION LOS THRESHOLDS..... 19**  
**TABLE 2-3: TRAFFIC SIGNAL WARRANT ANALYSIS LOCATIONS..... 20**  
**TABLE 3-1: INTERSECTION ANALYSIS FOR EXISTING (2020) CONDITIONS ..... 33**  
**TABLE 4-1: PROJECT TRIP GENERATION SUMMARY ..... 36**  
**TABLE 4-2: CUMULATIVE DEVELOPMENT LAND USE SUMMARY ..... 45**  
**TABLE 5-1: INTERSECTION ANALYSIS FOR EAP (2023) CONDITIONS ..... 54**  
**TABLE 6-1: INTERSECTION ANALYSIS FOR EAPC (2023) CONDITIONS..... 62**  
**TABLE 6-2: INTERSECTION ANALYSIS FOR EAPC (2023) CONDITIONS WITH IMPROVEMENTS ..... 64**  
**TABLE 7-1: INTERSECTION ANALYSIS FOR HORIZON YEAR (2040) CONDITIONS..... 70**  
**TABLE 7-2: INTERSECTION ANALYSIS FOR HORIZON YEAR (2040) CONDITIONS WITH IMPROVEMENTS**  
**..... 75**

This Page Intentionally Left Blank



## **LIST OF ABBREVIATED TERMS**

(1)	Reference
ADT	Average Daily Traffic
CA MUTCD	California Manual on Uniform Traffic Control Devices
Caltrans	California Department of Transportation
CMP	Congestion Management Program
DIF	Development Impact Fee
EAP	Existing Plus Ambient Growth Plus Project
EAPC	Existing Plus Ambient Growth Plus Project Plus Cumulative
HCM	Highway Capacity Manual
ITE	Institute of Transportation Engineers
LOS	Level of Service
NCHRP	National Cooperative Highway Research Program
PeMS	Performance Measurement System
PHF	Peak Hour Factor
Project	Glen Ivy Senior Community
RCTC	Riverside County Transportation Commission
RivTAM	Riverside County Transportation Analysis Model
RTA	Riverside Transit Authority
RTP/SCS	Regional Transportation Plan/Sustainable Communities Strategy
SCAG	Southern California Association of Governments
TA	Traffic Analysis
TUMF	Transportation Uniform Mitigation Fee
WRCOG	Western Riverside Council of Governments
V/C	Volume to Capacity

This Page Intentionally Left Blank

# 1 INTRODUCTION

This report presents the results of the traffic analysis (TA) for the proposed Glen Ivy Senior Community development (**Project**), which is located on the southwest corner of Temescal Canyon Road and Trilogy Parkway, as shown on Exhibit 1-1.

The purpose of this TA is to evaluate the potential deficiencies related to traffic and circulation system deficiencies that may result from the development of the proposed Project, and to recommend improvements to resolve identified deficiencies and to achieve acceptable circulation system operational conditions. This traffic study has been prepared in accordance with the County of Riverside's Traffic Impact Analysis Preparation Guide (August 2008), the California Department of Transportation (Caltrans) Guide for the Preparation of Traffic Impact Studies, and through consultation with County of Riverside staff during the scoping process. (1) (2) The approved Project Traffic Study Scoping agreement is provided in Appendix 1.1 of this TA.

## 1.1 SUMMARY OF FINDINGS

The Project is proposing to construct the following improvements as design features in conjunction with development of the site:

- Project to construct Temescal Canyon Road from Trilogy Parkway to the Project's southern boundary at its ultimate half-section width as a Major Highway (118-foot right-of-way) in compliance with the circulation recommendations found in the County of Riverside General Plan Circulation Element.
- Project to construct Trilogy Parkway from the Project's western boundary to Temescal Canyon Road at its ultimate half-section width as a Major Highway (118-foot right-of-way) in compliance with the circulation recommendations found in the County of Riverside General Plan Circulation Element.
- Project to modify the existing intersection/median at Driveway 1 on Trilogy Parkway.
- Stop controls are to be provided for egress traffic from the Project at all driveways.

Additional details and intersection lane geometrics are provided in Section 1.6 *Recommendations* of this report.

The development of the proposed Project is not anticipated to require the construction of any off-site improvements, however, there are improvement needs identified at off-site intersections for future traffic analysis scenarios where the Project would contribute traffic. As such, the Project Applicant's responsibility for the Project's contributions towards off-site intersection deficiencies is fulfilled through payment of fair share or participation in the pre-existing fee programs that would be assigned to construction of the identified recommended improvements. The Project Applicant would be required to pay requisite fair share contributions and fee payments consistent with the County's requirements (see Section 8 *Local and Regional Funding Mechanisms*).

EXHIBIT 1-1: PRELIMINARY SITE PLAN

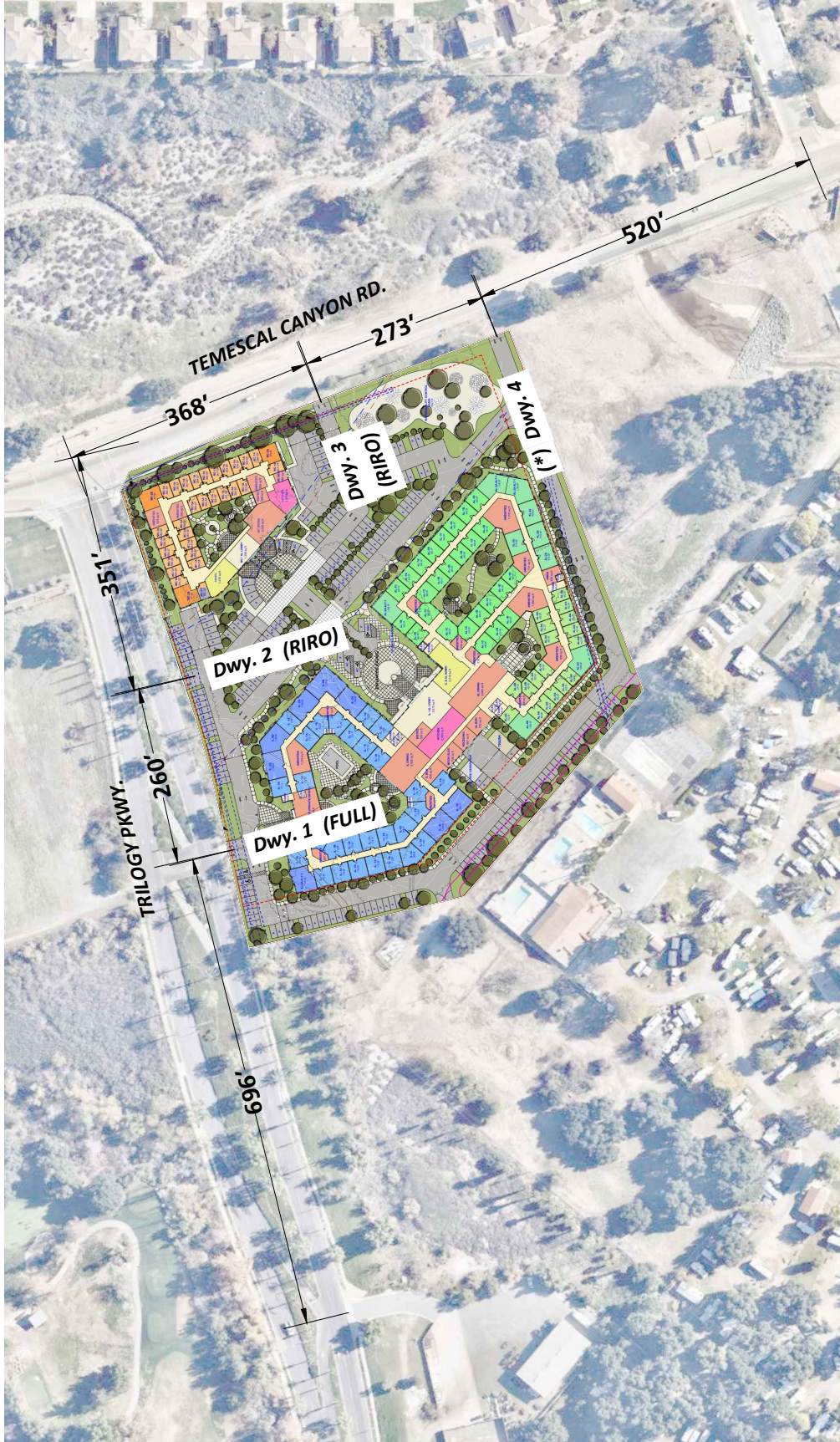

**LEGEND:**  
 RIRO = RIGHT-IN/RIGHT-OUT ONLY ACCESS  
 FULL = FULL ACCESS

\* Note: Driveway 4 is to be evaluated as right-in/right-out only and as full access.



## 1.2 PROJECT OVERVIEW

The proposed Project currently includes the development of 141 assisted living dwelling units (109 standard assisted living dwelling units and 32 memory care dwelling units) and 75 senior adult housing attached dwelling units. Trip generation for the assisted living use will consist of 129 beds for the standard assisted living and 35 memory care beds for a total of 164 beds. However, for the purposes of this TA, the previous plan (which is more conservative) has been evaluated, which consists of 130 beds of assisted living use and 35 memory care beds for standard assisted living for a total of 165 beds plus the 76 senior adult housing attached dwelling units. The Project opening year is 2023. Vehicular and truck traffic access will be provided via the following driveways (see Exhibit 1-1):

- Driveway 1 & Trilogy Parkway – Full access
- Driveway 2 & Trilogy Parkway – Right-in/right-out access only
- Temescal Canyon Road & Driveway 3 – Right-in/right-out access only
- Temescal Canyon Road & Driveway 4 – Evaluated both with right-in/right-out access only and full access

Regional access to the Project site is available from the I-15 Freeway via Temescal Canyon Road.

Trips generated by the Project's proposed land uses have been estimated based on trip generation rates collected by the Institute of Transportation Engineers (ITE) Trip Generation Manual, (10<sup>th</sup> Edition, 2017). (3) The proposed Project is anticipated to generate a total of 658 trip-ends per day, 42 AM peak hour trips and 57 PM peak hour trips. The assumptions and methods used to estimate the Project's trip generation characteristics are discussed in greater detail in Section 4.1 *Project Trip Generation* of this report.

## 1.3 ANALYSIS SCENARIOS

For the purposes of this traffic study, potential deficiencies to traffic and circulation have been assessed for each of the following conditions:

- Existing (2020)
- Existing Plus Ambient Growth Plus Project (EAP) (2023)
- Existing Plus Ambient Growth Plus Project Plus Cumulative Projects (EAPC) (2023)
- Horizon Year (2040) Without Project
- Horizon Year (2040) With Project

### 1.3.1 EXISTING (2020) CONDITIONS

Information for Existing (2020) conditions is disclosed to represent the baseline traffic conditions as they existed at the time this report was prepared. Due to the currently ongoing COVID-19 pandemic, schools and businesses within the study area were closed or operating at less than full capacity at the time this study was prepared. As such, historic (2018 and 2019) traffic counts were utilized in conjunction with a 2% per year growth rate (compounded annually) to reflect 2020 conditions (see Section 3.7 for additional discussion).

### **1.3.2 EXISTING PLUS AMBIENT GROWTH PLUS PROJECT (2023) CONDITIONS**

The EAP (2023) conditions analysis determines the potential circulation system deficiencies based on a comparison of the EAP traffic conditions to Existing conditions. To account for background traffic growth, an ambient growth factor from Existing (2020) conditions of 6.12% (2 percent per year, compounded over 3 years) is included for EAP (2023) traffic conditions. The assumed ambient growth factor is based on the requirements per the County of Riverside traffic study guidelines. Consistent with Riverside County traffic study guidelines, the EAP analysis is intended to identify “Opening Year” deficiencies associated with the development of the proposed Project based on the expected background growth within the study area.

### **1.3.3 EXISTING PLUS AMBIENT GROWTH PLUS PROJECT PLUS CUMULATIVE (2023) CONDITIONS**

The EAPC (2023) traffic conditions analysis determines the potential near-term cumulative circulation system deficiencies. To account for background traffic growth, an ambient growth factor of 6.12% from Existing conditions are included for EAPC traffic conditions (2 percent per year, compounded over 3 years).

Conservatively, the TA estimates the area ambient traffic growth and then adds traffic generated by other known or probable related projects. These related projects are at least in part already accounted for in the assumed 6.12% of ambient growth; and some of these related projects would likely not be implemented and operational within the 2023 Opening Year time frame assumed for the Project. The resulting traffic growth utilized in the TA (6.12% ambient growth factor plus traffic generated by related projects) would therefore tend to overstate rather than understate background cumulative traffic deficiencies under 2023 conditions.

### **1.3.4 HORIZON YEAR (2040) CONDITIONS**

Traffic projections for Horizon Year (2040) conditions were derived from the County of Riverside Transportation Analysis Model (RivTAM) using accepted procedures for model forecast refinement and smoothing. This scenario evaluates the circulation network in order to compare the findings between the County’s currently adopted General Plan, which includes the future Temescal Canyon Road extension, and the proposed circulation network modifications proposed by the Project. The Horizon Year conditions analyses will be utilized to determine if improvements funded through regional transportation mitigation fee programs, such as the Western Riverside Council of Governments (WRCOG) Transportation Uniform Mitigation Fee (TUMF) and Development Impact Fee (DIF) programs, can accommodate the long-range cumulative traffic at the target level of service (LOS) identified in the County of Riverside (lead agency) General Plan. (4) Each of these regional transportation fee programs are discussed in more detail in Section 8 *Local and Regional Funding Mechanisms*.

## 1.4 STUDY AREA

To ensure that this TA satisfies the County of Riverside’s traffic study requirements, Urban Crossroads, Inc. prepared a project traffic study scoping package for review by County of Riverside staff prior to the preparation of this report.

### 1.4.1 STUDY AREA INTERSECTIONS

The 6 study area intersections shown on Exhibit 1-2 and listed in Table 1-1 were selected for evaluation in this TA based on consultation with County of Riverside staff. The “50 peak hour trip” criteria represents a minimum number of trips at which a typical intersection would have the potential to be substantively affected by a given development proposal. The 50 peak hour trip criterion is a traffic engineering rule of thumb that is accepted and widely used within Riverside County for estimating a potential area of influence (i.e., study area). It should be noted that the Project is anticipated to contribute fewer than 50 peak hour trips to all study area intersections.

**TABLE 1-1: INTERSECTION ANALYSIS LOCATIONS**

ID	Intersection Location	Jurisdiction	CMP?
1	Driveway 1 & Trilogy Parkway – Future Intersection	County of Riverside	No
2	Driveway 2 & Trilogy Parkway – Future Intersection	County of Riverside	No
3	Temescal Canyon Road & Lawson Road	County of Riverside	No
4	Temescal Canyon Road & Trilogy Parkway	County of Riverside	No
5	Temescal Canyon Road & Driveway 3 – Future Intersection	County of Riverside	No
6	Temescal Canyon Road & Driveway 4 – Future Intersection	County of Riverside	No

The intent of a Congestion Management Program (CMP) is to more directly link land use, transportation, and air quality, thereby prompting reasonable growth management programs that will effectively utilize new transportation funds, alleviate traffic congestion and related deficiencies, and improve air quality. The County of Riverside CMP became effective with the passage of Proposition 111 in 1990 and updated most recently updated in 2011. The Riverside County Transportation Commission (RCTC) adopted the 2011 CMP for the County of Riverside in December 2011. (5) CMP intersections are identified in Table 1-1. There are no study area intersections identified as a Riverside County CMP facility.



EXHIBIT 1-2: LOCATION MAP



**LEGEND:**

- ①** = EXISTING INTERSECTION ANALYSIS LOCATION
- ②** = FUTURE INTERSECTION ANALYSIS LOCATION

\* Note: Driveway 4 is to be evaluated as right-in/right-out only and as full access.





## 1.5 DEFICIENCIES

This section provides a summary of deficiencies by analysis scenario. Section 2 *Methodologies* provides information on the methodologies used in the analysis and Section 5 *EAP (2023) Traffic Conditions*, Section 6 *EAPC (2023) Traffic Conditions*, and Section 7 *Horizon Year (2040) Traffic Conditions* includes the detailed analysis. A summary of LOS results for all analysis scenarios is presented on Exhibit 1-3.

### 1.5.1 EAP (2023) CONDITIONS

All of the study area intersections are anticipated to continue to operate at an acceptable LOS, consistent with Existing (2020) traffic conditions.

### 1.5.2 EAPC (2023) CONDITIONS

The following study area intersection is anticipated to operate at a deficient LOS (i.e., LOS E or worse) during one or both peak hours for EAPC (2023) traffic conditions:

- Temescal Canyon Road & Lawson Road (#3) – LOS F AM and PM peak hours

The intersection of Temescal Canyon Road and Driveway 4 is anticipated to operate at an unacceptable LOS with full access at Driveway 4 only for EAPC (2023) traffic conditions.

### 1.5.3 HORIZON YEAR (2040) CONDITIONS

The following study area intersections are anticipated to operate at a deficient LOS (i.e., LOS E or worse) during one or both peak hours under Horizon Year (2040) Without Project traffic conditions:

- Temescal Canyon Road & Lawson Road (#3) – LOS F AM and PM peak hours
- Temescal Canyon Road & Trilogy Parkway (#4) – LOS F AM peak hour only

With the addition of Project traffic, there are no additional intersections anticipated to result in an unacceptable LOS in addition to the intersections previously identified under Horizon Year (2040) Without Project traffic conditions. However, the intersection of Temescal Canyon Road and Driveway 4 is anticipated to operate at an unacceptable LOS with full access at Driveway 4 only for Horizon Year (2040) With Project traffic conditions.

**EXHIBIT 1-3: SUMMARY OF DEFICIENT INTERSECTIONS BY ANALYSIS SCENARIO**

#	Intersection	Existing (2023)	EAP (2023) RIRO	EAP (2023) FULL	EAPC (2023) RIRO	EAPC (2023) FULL	Horizon Year (2040) Without Project	Horizon Year (2040) RIRO With Project	Horizon Year (2040) FULL With Project
1	Driveway 1 & Trilogy Pkwy.	NA	●	●	●	●	NA	●	●
2	Driveway 2 & Trilogy Pkwy.	NA	●	●	●	●	NA	●	●
3	Temescal Canyon Rd. & Lawson Rd.	●	●	●	●	●	●	●	●
4	Temescal Canyon Rd. & Trilogy Pkwy.	●	●	●	●	●	●	●	●
5	Temescal Canyon Rd. & Driveway 3	NA	●	●	●	●	NA	●	●
6	Temescal Canyon Rd. & Driveway 4	NA	●	●	●	●	NA	●	●

**LEGEND:**

- AM PEAK HOUR
- PM PEAK HOUR
- LOS A-D
- LOS E
- LOS F
- NA - NOT AN ANALYSIS LOCATION FOR THIS SCENARIO



## 1.6 RECOMMENDATIONS

### 1.6.1 SITE ADJACENT AND SITE ACCESS RECOMMENDATIONS

The following recommendations are based on the improvements needed to accommodate site access. Exhibit 1-4 shows the site adjacent recommendations.

At the intersection of Temescal Canyon Road & Trilogy Parkway (#4), no improvements are recommended; the existing traffic control and intersection geometrics should be maintained.

**Recommendation 1 – Driveway 1 & Trilogy Parkway (#1)** – The following improvements are necessary to accommodate site access:

- Project to install a stop control on the northbound approach.
- Project to construct shared northbound left-through-right turn lane.
- Project to construct a westbound left turn lane with a minimum of 100-feet of storage.
- A preliminary design for the intersection of Driveway 1 is shown on Exhibit 1-5.

**Recommendation 2 – Driveway 2 & Trilogy Parkway (#2)** – The following improvements are necessary to accommodate site access:

- Project to install a stop control on the northbound approach.
- Project to construct a northbound right turn lane.

**Recommendation 3 – Temescal Canyon Road & Driveway 3 (#5)** – The following improvements are necessary to accommodate site access:

- Project to install a stop control on the eastbound approach.
- Project to construct an eastbound right turn lane.
- Project to construct a 2<sup>nd</sup> southbound through lane.

**Recommendation 4 – Temescal Canyon Road & Driveway 4 (#6)** – The following improvement is necessary to accommodate site access:

- Project to install a stop control on the eastbound approach.
- If the Project is developed with full access, then Project to construct with a shared eastbound left-right turn lane. If the Project is developed with restricted access, then Project to construct an eastbound right turn lane.
- Project to construct a 2<sup>nd</sup> southbound through lane. The 2<sup>nd</sup> southbound through lane should be striped in the future when Temescal Canyon Road is widened to the south to accommodate the receiving lanes.
- If the Project is developed with full access, then Project to construct a northbound left turn lane with a minimum of 100-feet of storage.
- A preliminary design for the intersection of Driveway 4 is also shown on Exhibit 1-5.

**EXHIBIT 1-4: SITE ADJACENT ROADWAY AND SITE ACCESS RECOMMENDATIONS**

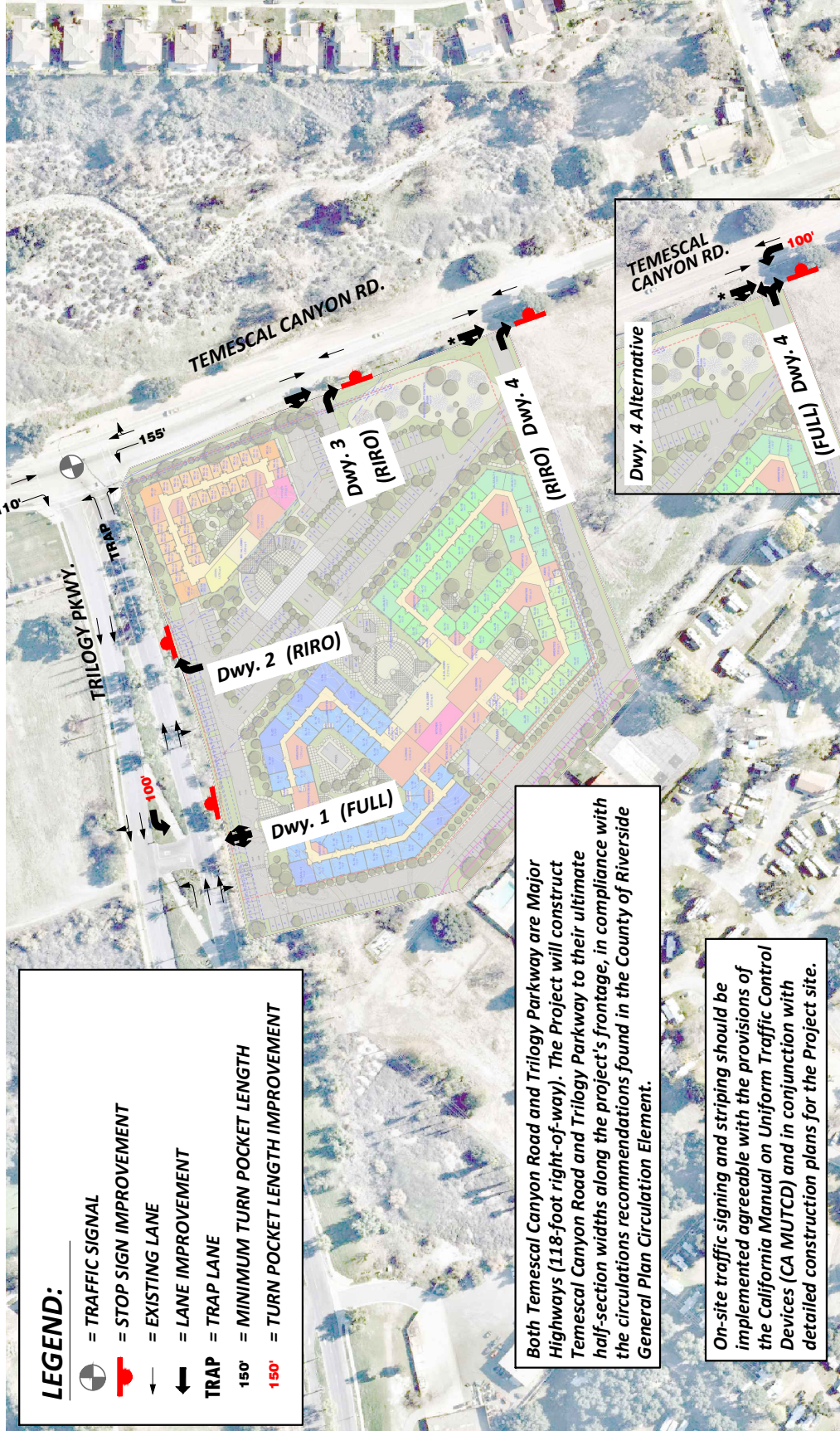

**LEGEND:**

- = TRAFFIC SIGNAL
- = STOP SIGN IMPROVEMENT
- = EXISTING LANE
- = LANE IMPROVEMENT
- = TRAP LANE
- = MINIMUM TURN POCKET LENGTH
- = TURN POCKET LENGTH IMPROVEMENT

Both Temescal Canyon Road and Trilogly Parkway are Major Highways (118-foot right-of-way). The Project will construct Temescal Canyon Road and Trilogly Parkway to their ultimate half-section widths along the project's frontage, in compliance with the circulations recommendations found in the County of Riverside General Plan Circulation Element.

On-site traffic signing and striping should be implemented agreeable with the provisions of the California Manual on Uniform Traffic Control Devices (CA MUTCD) and in conjunction with detailed construction plans for the Project site.

Sight distance at each project access point should be reviewed with respect to standard Caltrans and sight distance standards at the time of preparation of final grading, landscape and street improvement plans.

\* Note: Second through lane to be striped in the future when Temescal Canyon Road is widened to the south.





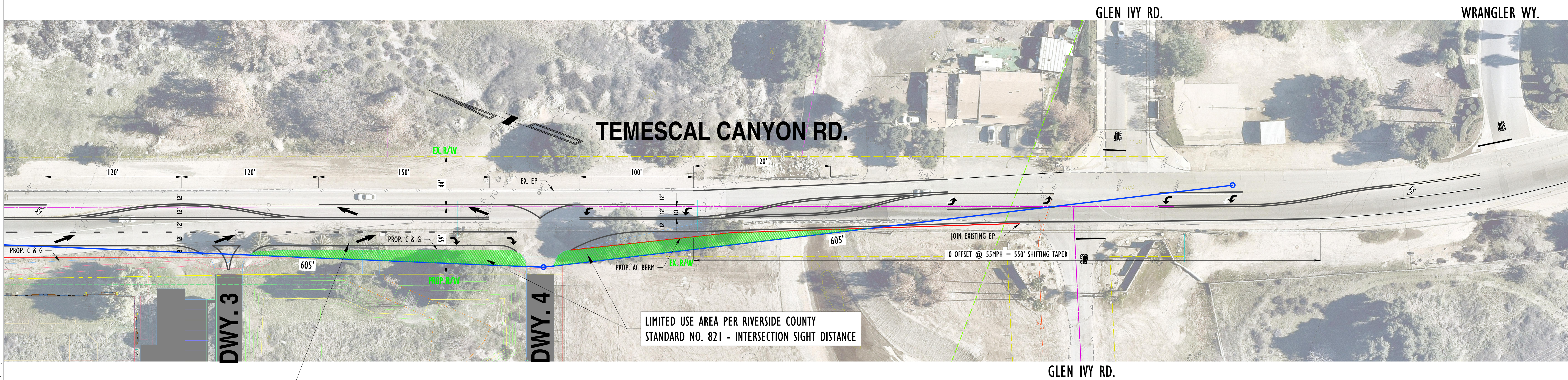
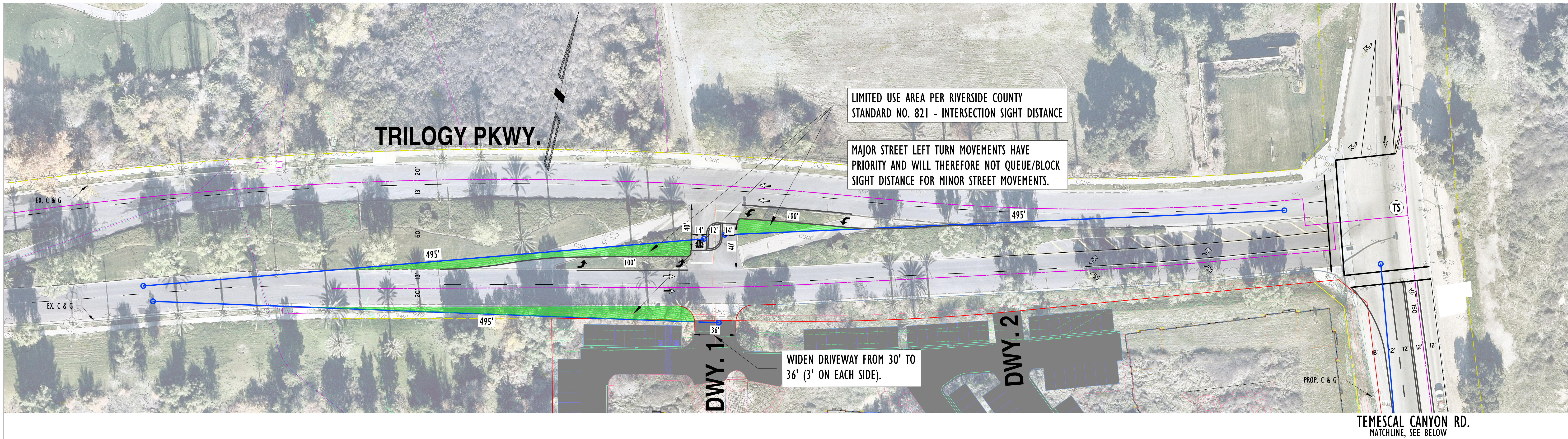

2ND SOUTHBOUND THROUGH LANE TO BE STRIPED IN THE FUTURE (WHEN TEMESCAL CANYON ROAD TO THE SOUTH IS WIDENED)

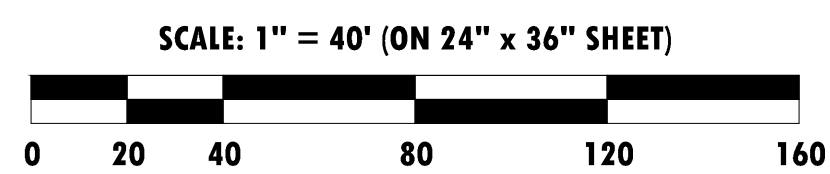

## EXHIBIT 1-5: TRIOLOGY PARKWAY & TEMESCAL CANYON ROAD CONCEPT STRIPING



WWW.URBANROADS.COM  
TELEPHONE: 949-660-1994



This Page Intentionally Left Blank

**Recommendation 5 – Temescal Canyon Road** is a north-south oriented roadway located along the Project’s eastern boundary. Project to construct Temescal Canyon Road from Trilogy Parkway to the Project’s southern boundary at its ultimate half-section width as a Major Highway (118-foot right-of-way) in compliance with the circulation recommendations found in the County of Riverside General Plan Circulation Element.

**Recommendation 6 – Trilogy Parkway** is an east-west oriented roadway located along the Project’s northern boundary. Project to construct Trilogy Parkway from the Project’s western boundary to Temescal Canyon Road at its ultimate half-section width as a Major Highway (118-foot right-of-way) in compliance with the circulation recommendations found in the County of Riverside General Plan Circulation Element.

On-site traffic signing and striping should be implemented agreeable with the provisions of the California Manual on Uniform Traffic Control Devices (CA MUTCD) and in conjunction with detailed construction plans for the Project site.

Sight distance at each project access point should be reviewed with respect to standard Caltrans and County of Riverside sight distance standards at the time of preparation of final grading, landscape and street improvement plans.

#### **1.6.2 OFF-SITE RECOMMENDATIONS**

The recommended improvements needed to address the cumulative deficiencies identified under Existing (2020), EAP (2023), EAPC (2023), and Horizon Year (2040) traffic conditions are shown in Table 1-2. For those improvements listed in Table 1-2 and not constructed as part of the Project, the Applicant’s responsibility for the Project’s contributions towards deficient intersections is fulfilled through payment of fair share and/or TUMF/DIF fees (if applicable) that would be assigned to construction of the identified recommended improvements. The Project Applicant would be required to pay TUMF/DIF and/or fair share fees consistent with the County’s requirements (see Section 8 *Local and Regional Funding Mechanisms*).

This Page Intentionally Left Blank



Table 1-2

Summary of Improvements by Analysis Scenario

#	Intersection Location	Jurisdiction	Existing (2020)	EAP (2023)	EAPC (2023)	2040 With Project	Improvements in County TUMF/DIF? <sup>1</sup>	Project Responsibility <sup>3</sup>	Fair Share % <sup>4</sup>
3	Temescal Canyon Rd. & Lawson Rd.	County of Riverside	None	None	Install a traffic signal Add 2nd NB through lane Add 2nd SB through lane	Same Same Same	Yes (DIF) <sup>2</sup> Yes (TUMF) <sup>2</sup> Yes (TUMF) <sup>2</sup>	Fees Fees Fees	N/A
4	Temescal Canyon Rd. & Trilogy Pkwy.	County of Riverside	None	None	None	Add 2nd NB through lane Add 2nd SB through lane	Yes (TUMF) <sup>2</sup> Yes (TUMF) <sup>2</sup>	Fees Fees	N/A
6	Temescal Canyon Rd. & Driveway 4	County of Riverside	None	None	Add 2nd NB through lane <sup>5</sup> Add 2nd SB through lane <sup>5,6</sup>	Same Same	Yes (TUMF) <sup>2</sup> Yes (TUMF) <sup>2</sup>	Fees	N/A

<sup>1</sup> Improvements included in TUMF Nexus, or County of Riverside DIF fee programs.

<sup>2</sup> Although a TUMF facility, the roadway widening is not currently identified on the 2020 Northwest Zone 5-Year Transportation Improvement Program Amendment.

<sup>3</sup> Identifies the Project's responsibility to construct an improvement or contribute fair share towards the implementation of the improvements shown.

<sup>4</sup> Program improvements constructed by project may be eligible for fee credit, at discretion of County.

<sup>5</sup> Improvement only required with implementation of full access at Driveway 4.

<sup>6</sup> Improvement will be constructed by the Project as part of the Project design features. As such, this improvement is not needed for "Without Project" conditions.

This Page Intentionally Left Blank

## 2 METHODOLOGIES

This section of the report presents the methodologies used to perform the traffic analyses summarized in this report. The methodologies described are generally consistent with County of Riverside and Caltrans traffic study guidelines. (1) (2)

### 2.1 LEVEL OF SERVICE

Traffic operations of roadway facilities are described using the term "Level of Service" (LOS). LOS is a qualitative description of traffic flow based on several factors such as speed, travel time, delay, and freedom to maneuver. Six levels are typically defined ranging from LOS A, representing completely free-flow conditions, to LOS F, representing breakdown in flow resulting in stop-and-go conditions. LOS E represents operations at or near capacity, an unstable level where vehicles are operating with the minimum spacing for maintaining uniform flow.

### 2.2 INTERSECTION CAPACITY ANALYSIS

The definitions of LOS for interrupted traffic flow (flow restrained by the existence of traffic signals and other traffic control devices) differ slightly depending on the type of traffic control. The LOS is typically dependent on the quality of traffic flow at the intersections along a roadway. The Highway Capacity Manual (HCM) methodology expresses the LOS at an intersection in terms of delay time for the various intersection approaches. (6) The HCM uses different procedures depending on the type of intersection control.

#### 2.2.1 SIGNALIZED INTERSECTIONS

##### *County of Riverside*

The County of Riverside requires signalized intersection operations analysis based on the methodology described in the HCM (6<sup>th</sup> Edition). Intersection LOS operations are based on an intersection's average control delay. Control delay includes initial deceleration delay, queue move-up time, stopped delay, and final acceleration delay. For signalized intersections LOS is directly related to the average control delay per vehicle and is correlated to a LOS designation as described in Table 2-1. Study area intersections have been evaluated using the Synchro (Version 10) analysis software package.

The traffic modeling and signal timing optimization software package Synchro (Version 10) is utilized to analyze signalized intersections within the County of Riverside and City of Corona. Synchro is a macroscopic traffic software program that is based on the signalized intersection capacity analysis as specified in the HCM. Macroscopic level models represent traffic in terms of aggregate measures for each movement at the study intersections. Equations are used to determine measures of effectiveness such as delay and queue length. The level of service and capacity analysis performed by Synchro takes into consideration optimization and coordination of signalized intersections within a network.

**TABLE 2-1: SIGNALIZED INTERSECTION LOS THRESHOLDS**

Description	Average Control Delay (Seconds), V/C ≤ 1.0	Level of Service, V/C ≤ 1.0	Level of Service, V/C > 1.0
Operations with very low delay occurring with favorable progression and/or short cycle length.	0 to 10.00	A	F
Operations with low delay occurring with good progression and/or short cycle lengths.	10.01 to 20.00	B	F
Operations with average delays resulting from fair progression and/or longer cycle lengths. Individual cycle failures begin to appear.	20.01 to 35.00	C	F
Operations with longer delays due to a combination of unfavorable progression, long cycle lengths, or high V/C ratios. Many vehicles stop and individual cycle failures are noticeable.	35.01 to 55.00	D	F
Operations with high delay values indicating poor progression, long cycle lengths, and high V/C ratios. Individual cycle failures are frequent occurrences. This is considered to be the limit of acceptable delay.	55.01 to 80.00	E	F
Operation with delays unacceptable to most drivers occurring due to over saturation, poor progression, or very long cycle lengths	80.01 and up	F	F

Source: HCM, 6<sup>th</sup> Edition

A saturation flow rate of 1900 has been utilized for all study area intersections located within the County of Riverside and City of Corona. The peak hour traffic volumes are adjusted using a peak hour factor (PHF) to reflect peak 15-minute volumes. Common practice for LOS analysis is to use a peak 15-minute rate of flow. However, flow rates are typically expressed in vehicles per hour. The PHF is the relationship between the peak 15-minute flow rate and the full hourly volume (e.g.  $PHF = \frac{[Hourly Volume]}{[4 \times Peak\ 15\text{-minute\ Flow\ Rate}]}$ ). The use of a 15-minute PHF produces a more detailed analysis as compared to analyzing vehicles per hour. Existing PHFs have been used for all analysis scenarios. Per the HCM, PHF values over 0.95 often are indicative of high traffic volumes with capacity constraints on peak hour flows while lower PHF values are indicative of greater variability of flow during the peak hour. (6)

**2.2.2 UNSIGNALIZED INTERSECTIONS**

The County of Riverside requires the operations of unsignalized intersections be evaluated using the methodology described the HCM. (6) The LOS rating is based on the weighted average control delay expressed in seconds per vehicle (see Table 2-2).

**TABLE 2-2: UNSIGNALIZED INTERSECTION LOS THRESHOLDS**

Description	Average Control Delay Per Vehicle (Seconds)	Level of Service, V/C ≤ 1.0	Level of Service, V/C > 1.0
Little or no delays.	0 to 10.00	A	F
Short traffic delays.	10.01 to 15.00	B	F
Average traffic delays.	15.01 to 25.00	C	F
Long traffic delays.	25.01 to 35.00	D	F
Very long traffic delays.	35.01 to 50.00	E	F
Extreme traffic delays with intersection capacity exceeded.	> 50.00	F	F

Source: HCM, 6<sup>th</sup> Edition

At two-way or side-street stop-controlled intersections, LOS is calculated for each controlled movement and for the left turn movement from the major street, as well as for the intersection as a whole. For approaches composed of a single lane, the delay is computed as the average of all movements in that lane. For all-way stop controlled intersections, LOS is computed for the intersection as a whole. For side-street stop-controlled intersections, LOS is reported for the worst minor street movement.

**2.3 TRAFFIC SIGNAL WARRANT ANALYSIS METHODOLOGY**

The term "signal warrants" refers to the list of established criteria used by the Caltrans and other public agencies to quantitatively justify or ascertain the potential need for installation of a traffic signal at an otherwise unsignalized intersection. This TA uses the signal warrant criteria presented in the latest edition of the Caltrans California Manual on Uniform Traffic Control Devices (CA MUTCD). (7)

The signal warrant criteria for Existing conditions are based upon several factors, including volume of vehicular and pedestrian traffic, frequency of accidents, and location of school areas. The Caltrans CA MUTCD indicates that the installation of a traffic signal should be considered if one or more of the signal warrants are met. (7) Specifically, this TA utilizes the Peak Hour Volume-based Warrant 3 as the appropriate representative traffic signal warrant analysis for existing study area intersections for all analysis scenarios. Warrant 3 is appropriate to use for this TA because it provides specialized warrant criteria for intersections with rural characteristics (e.g. located in communities with populations of less than 10,000 persons or with adjacent major streets operating above 40 miles per hour). For the purposes of this study, the speed limit was the basis for determining whether Urban or Rural warrants were used for a given intersection.

Future intersections that do not currently exist have been assessed regarding the potential need for new traffic signals based on future average daily traffic (ADT) volumes, using the Caltrans planning level ADT-based signal warrant analysis worksheets.

Traffic signal warrant analyses were performed for the following unsignalized study area intersection shown in Table 2-3:

**TABLE 2-3: TRAFFIC SIGNAL WARRANT ANALYSIS LOCATIONS**

ID	Intersection Location	Jurisdiction
1	Driveway 1 & Trilogy Parkway – Future Intersection	County of Riverside
3	Temescal Canyon Road & Lawson Road	County of Riverside
6	Temescal Canyon Road & Driveway 4 – Future Intersection	County of Riverside

Although unsignalized, traffic signal warrants have not been performed for the intersection of Driveway 2 on Trilogy and Driveway 3 on Temescal Canyon Road since these intersections are proposed to be restricted to right-in/right-out access only. The Existing conditions traffic signal warrant analysis is presented in the subsequent section, Section 3 *Area Conditions* of this report. The traffic signal warrant analyses for future conditions are presented in Section 5 *EAP (2023) Traffic Conditions*, Section 6 *EAPC (2023) Traffic Conditions*, and Section 7 *Horizon Year (2040) Traffic Conditions* of this report.

It is important to note that a signal warrant defines the minimum condition under which the installation of a traffic signal might be warranted. Meeting this threshold condition does not require that a traffic control signal be installed at a particular location, but rather, that other traffic factors and conditions be evaluated in order to determine whether the signal is truly justified. It should also be noted that signal warrants do not necessarily correlate with LOS. An intersection may satisfy a signal warrant condition and operate at or above acceptable LOS or operate below acceptable LOS and not meet a signal warrant.

**2.4 MINIMUM LEVEL OF SERVICE (LOS)**

The definition of an intersection deficiency has been obtained from the County of Riverside General Plan. Riverside County General Plan Policy C 2.1 states that the County will maintain the following County-wide target LOS:

*The following minimum target levels of service have been designated for the review of development proposals in the unincorporated areas of Riverside County with respect to transportation impacts on roadways designated in the Riverside County Circulation Plan which are currently County maintained, or are intended to be accepted into the County maintained roadway system:*

- *LOS C shall apply to all development proposals in any area of the Riverside County not located within the boundaries of an Area Plan, as well as those areas located within the following Area Plans: REMAP, Eastern Coachella Valley, Desert Center, Palo Verde Valley, and those non-Community Development areas of the Elsinore, Lake Mathews/Woodcrest, Mead Valley and Temescal Canyon Area Plans.*
- *LOS D shall apply to all development proposals located within any of the following Area Plans: Eastvale, Jurupa, Highgrove, Reche Canyon/Badlands, Lakeview/Nuevo, Sun City/Menifee Valley, Harvest Valley/Winchester, Southwest Area, The Pass, San Jacinto Valley, Western Coachella*

*Valley and those Community Development Areas of the Elsinore, Lake Mathews/Woodcrest, Mead Valley and Temescal Canyon Area Plans.*

- *LOS E may be allowed by the Board of Supervisors within designated areas where transit-oriented development and walkable communities are proposed.*

The applicable minimum LOS utilized for the purposes of this analysis is LOS D per the County-wide target LOS for projects located within a Community Development Area of the Temescal Canyon Area Plan.

## **2.5 DEFICIENCY CRITERIA**

This section outlines the methodology used in this analysis related to identifying circulation system deficiencies. The following deficiency criteria has been utilized for the County of Riverside. To determine whether the addition of project-related traffic at a study intersection would result in a deficiency, the following will be utilized:

- A deficiency occurs at study area intersections if the pre-Project condition is at or better than LOS D (i.e., acceptable LOS), and the addition of project trips causes the peak hour LOS of the study area intersection to operate at unacceptable LOS (i.e., LOS E or F). Per the County of Riverside traffic study guidelines, for intersections currently operating at unacceptable LOS (LOS E or F), a deficiency will occur if the Project contributes 50 or more peak hour trips to pre-project traffic conditions.

This Page Intentionally Left Blank



### 3 AREA CONDITIONS

This section provides a summary of the existing circulation network, the County of Riverside General Plan Circulation Network, and a review of existing peak hour intersection operations and traffic signal warrant analyses.

#### 3.1 EXISTING CIRCULATION NETWORK

Pursuant to the scoping agreement with County of Riverside staff (Appendix 1.1), the study area includes a total of 6 existing and future intersections as shown previously on Exhibit 1-2, where the Project is anticipated to contribute 50 or more peak hour trips or has been added at the direction of County staff. Exhibit 3-1 illustrates the study area intersections located near the proposed Project and identifies the number of through traffic lanes for existing roadways and intersection traffic controls.

#### 3.2 GENERAL PLAN CIRCULATION ELEMENTS

As noted previously, the Project site is located within the County of Riverside. The roadway classifications and planned (ultimate) roadway cross-sections of the major roadways within the study area, as identified on County of Riverside General Plan Circulation Element, are described subsequently. Exhibit 3-2 shows the County of Riverside General Plan Circulation Element and Exhibit 3-3 illustrates the County of Riverside General Plan roadway cross-sections.

**Major Highways** can accommodate four travel lanes. These facilities serve property zoned for major industrial and commercial uses, or to serve through traffic. The following roadways are classified as a Major Highway within the study area:

- Temescal Canyon Road (at I-15 interchange and from Trilogy Parkway to Campbell Ranch Road)
- Trilogy Parkway

**Collectors** can accommodate two travel lanes. These facilities provide access to residential land use, or commercial and industrial land use in the form of a cul-de-sac. The following roadway is classified as a collector within the study area:

- Temescal Canyon Road (from I-15 interchange to Trilogy Parkway)

**EXHIBIT 3-1: EXISTING NUMBER OF THROUGH LANES AND INTERSECTION CONTROLS**

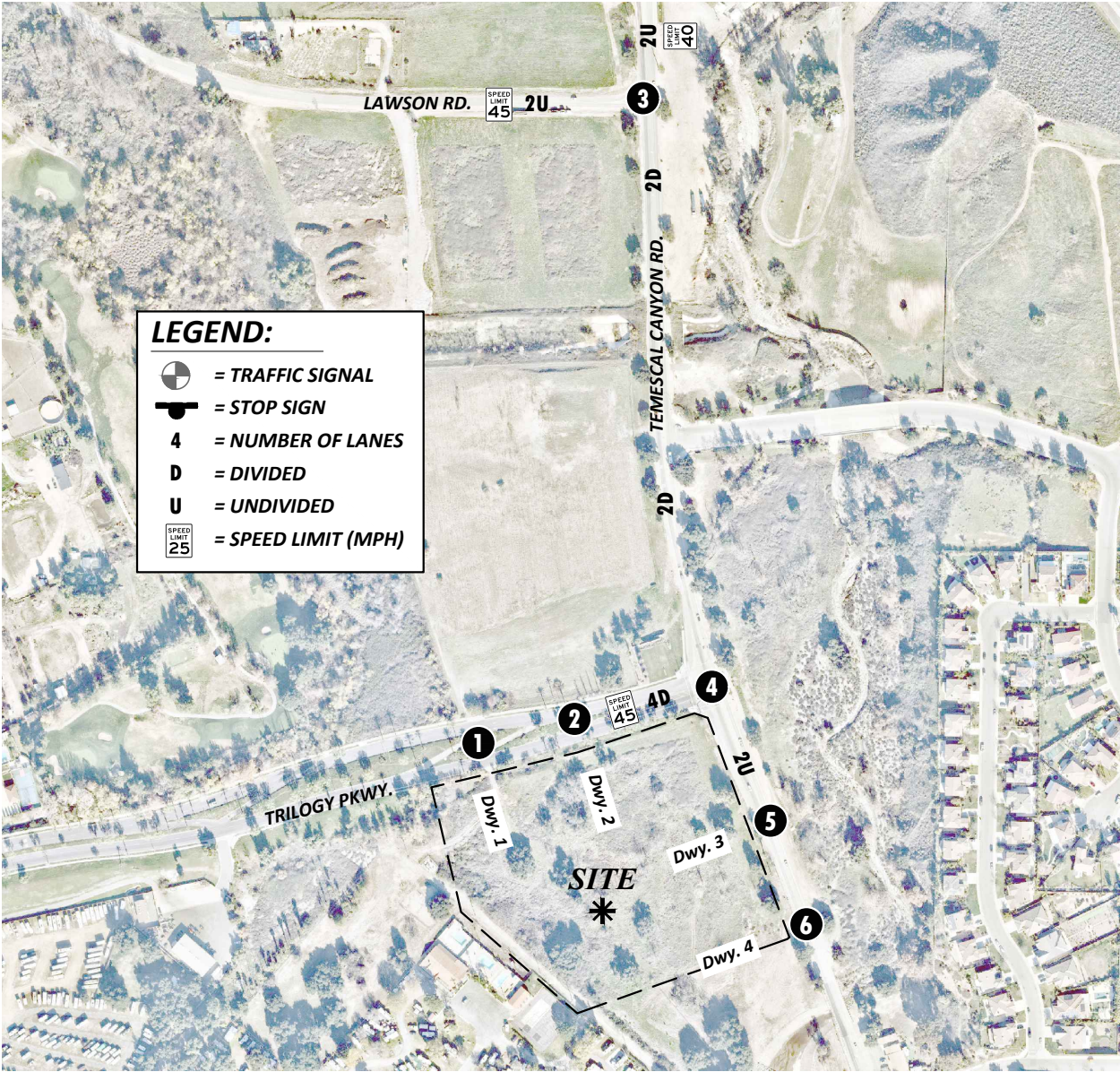

**LEGEND:**

- = TRAFFIC SIGNAL
- = STOP SIGN
- 4** = NUMBER OF LANES
- D** = DIVIDED
- U** = UNDIVIDED
- = SPEED LIMIT (MPH)

<b>1</b>	<b>2</b>	<b>3</b>	<b>4</b>	<b>5</b>	<b>6</b>
Dwy. 1 & Trilogy Pkwy.	Dwy. 2 & Trilogy Pkwy.	Temescal Canyon Rd. & Lawson Rd.	Temescal Canyon Rd. & Trilogy Pkwy.	Temescal Canyon Rd. & Dwy. 3	Temescal Canyon Rd. & Dwy. 4
Future Intersection	Future Intersection			Future Intersection	Future Intersection



**EXHIBIT 3-2: COUNTY OF RIVERSIDE GENERAL PLAN CIRCULATION ELEMENT**

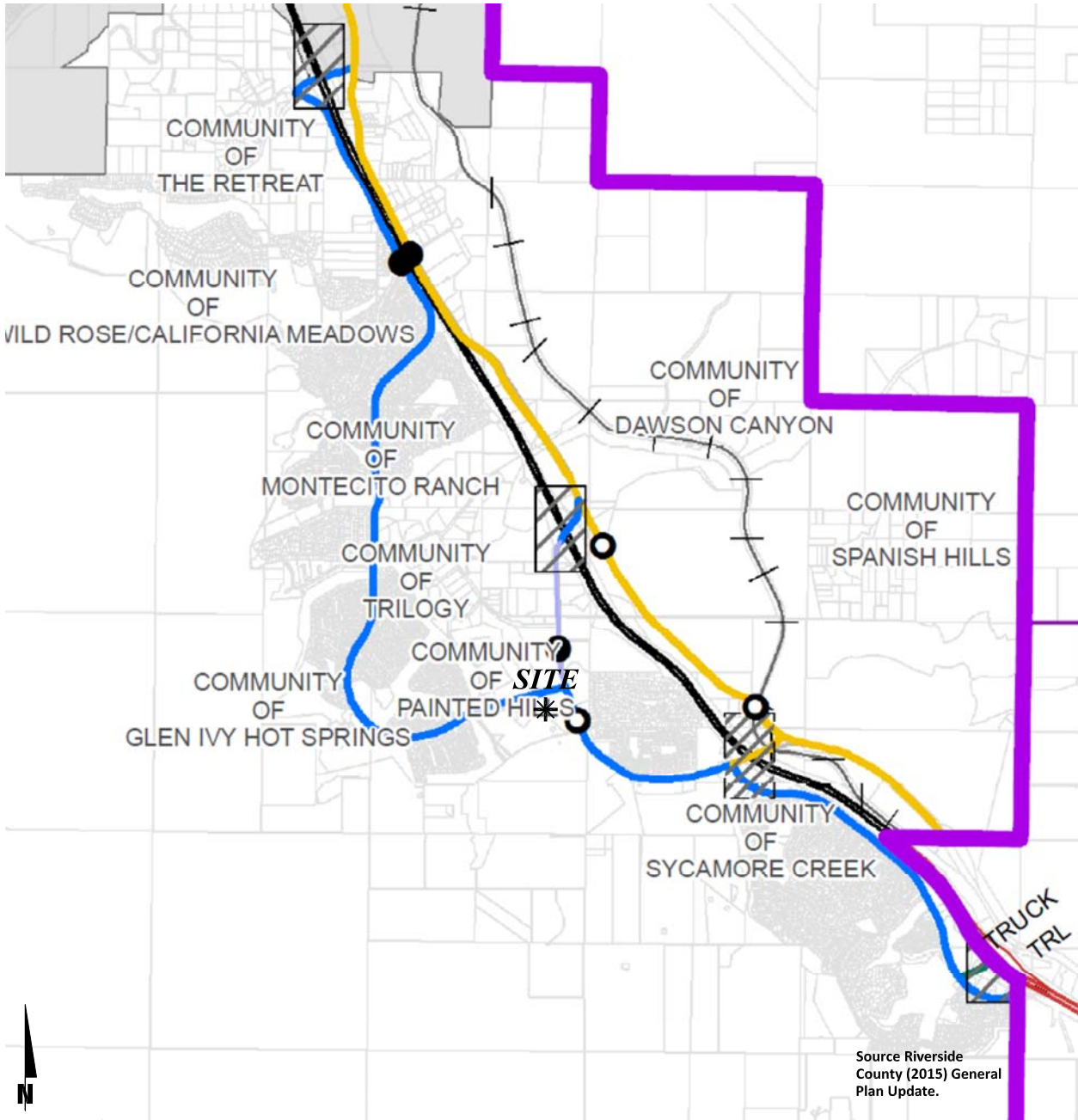

**LEGEND:**

- |                                   |                      |                 |                    |
|-----------------------------------|----------------------|-----------------|--------------------|
| Freeway (Variable ROW)            | Existing Interchange | Existing Bridge | Highways           |
| Expressway (128' to 220' ROW)     | Proposed Interchange | Proposed Bridge | Area Plan Boundary |
| Urban Arterial (152' ROW)         | Railroads Amended    | City Boundary   | Waterbodies        |
| Arterial (128' ROW)               |                      |                 |                    |
| Major (118' ROW)                  |                      |                 |                    |
| Secondary (100' ROW)              |                      |                 |                    |
| Mountain Arterial 2 Ln (110' ROW) |                      |                 |                    |
| Collector (74' ROW)               |                      |                 |                    |

**EXHIBIT 3-3: COUNTY OF RIVERSIDE GENERAL PLAN ROADWAY CROSS-SECTIONS**

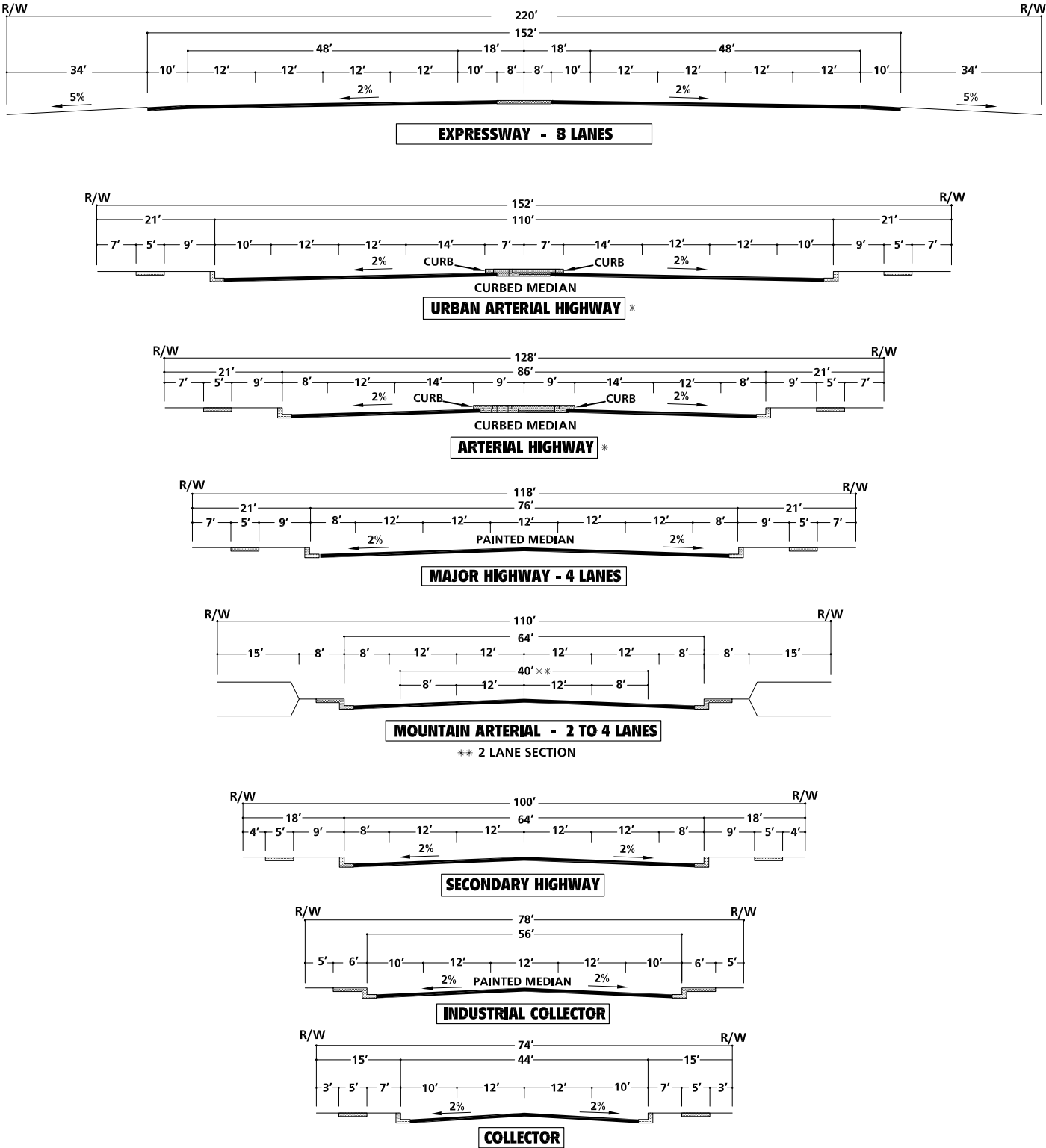

\* IMPROVEMENTS MAY BE RECONFIGURED TO ACCOMMODATE EXCLUSIVE TRANSIT LANES OR ALTERNATIVE LANE ARRANGEMENTS ADDITIONAL RIGHT OF WAY MAY BE REQUIRED AT INTERSECTIONS TO ACCOMMODATE ULTIMATE IMPROVEMENTS FOR STATE HIGHWAYS SHALL CONFORM TO CALTRANS DESIGN STANDARDS.

NOT TO SCALE

SOURCE: COUNTY OF RIVERSIDE





### **3.3 BICYCLE & PEDESTRIAN FACILITIES**

In an effort to promote alternative modes of transportation, the County of Riverside also includes a trails and bikeway system. The trails and bikeway system, shown on Exhibit 3-4, shows the proposed trails connected with major features within the County. There is a proposed historic trail along Temescal Canyon Road and a proposed community trail on the north side of Trilogy Parkway. Field observations conducted in December 2019 indicates nominal pedestrian and bicycle activity within the study area. Exhibit 3-5 illustrates the existing pedestrian facilities, including sidewalks and crosswalks. As shown on Exhibit 3-5, there are limited existing pedestrian facilities located along portions of Trilogy Parkway within the study area.

### **3.4 TRANSIT SERVICE**

The County of Riverside is currently served by the Riverside Transit Authority (RTA), a public transit agency serving the unincorporated Riverside County region. There are currently no existing bus routes that serve the roadways within the study area in close proximity to the proposed Project. Transit service is reviewed and updated by RTA periodically to address ridership, budget and community demand needs. Changes in land use can affect these periodic adjustments which may lead to either enhanced or reduced service where appropriate. As such, it is recommended that the Project Applicant work in conjunction with RTA to potentially accommodate bus service to the site.

**EXHIBIT 3-4: COUNTY OF RIVERSIDE TRAILS AND BIKEWAY SYSTEM**

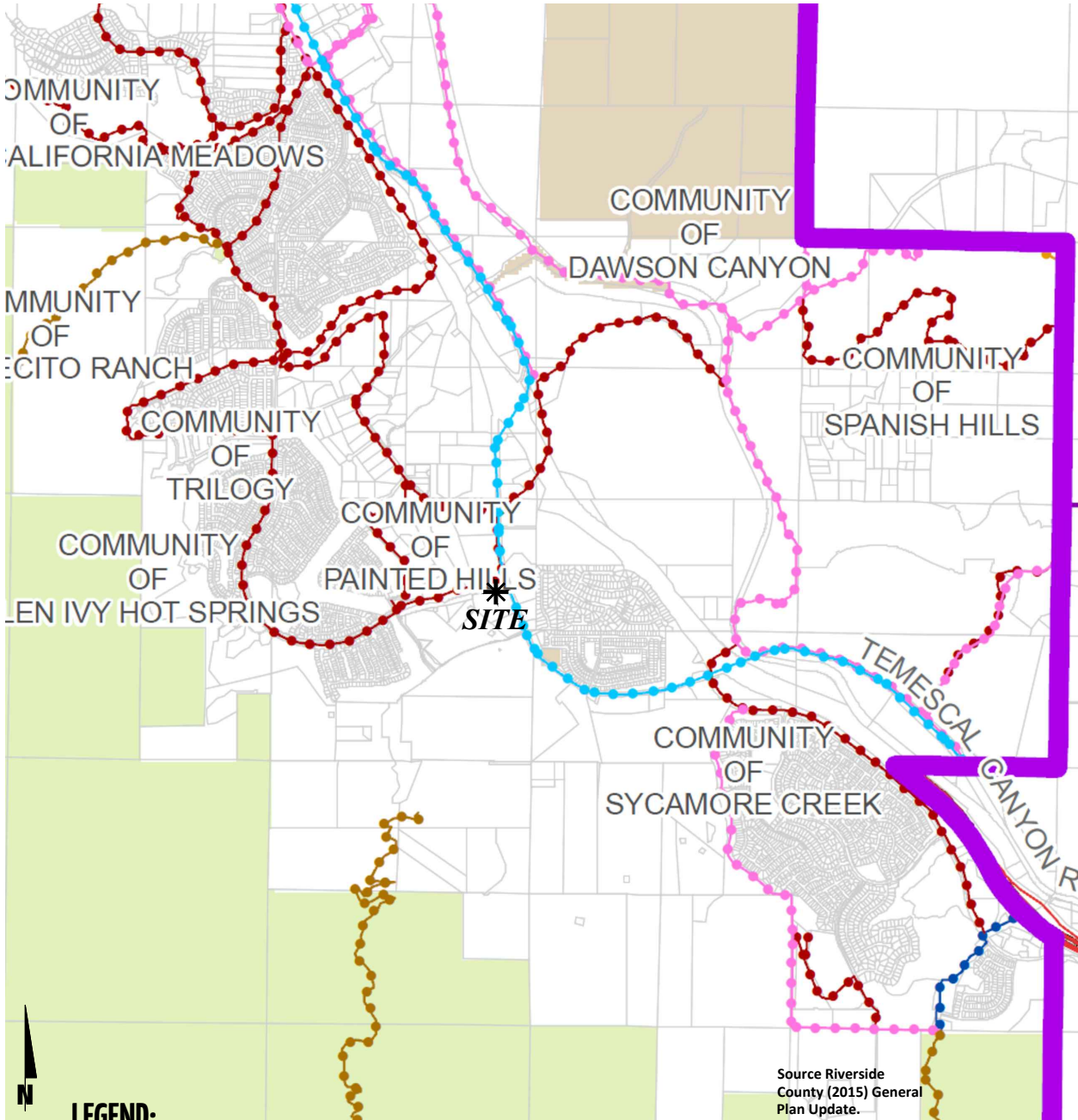

- LEGEND:**
- Regional Trail: Urban/Suburban
  - Community Trail
  - Combination Trail (Regional Trail / Class I Bike Path)
  - Class I Bike Path
  - Regional Trail: Open Space
  - Design Guidelines Trail
  - Historic Trail (Southern Immigrant Trail, Juan Bautista De Anza National Historic Trail)
  - Non-County Trail (Public and Quasi-Public Lands)
  - Miscellaneous Public Lands
  - Bureau of Land Management (BLM) Lands
  - Highways
  - Area Plan Boundary
  - City Boundary
  - Waterbodies

Source Riverside County (2015) General Plan Update.

Data Source: Riverside County Parks

Note: Trails shown in non-county jurisdictions for information/coordination purposes only.

Data Source: Primarily Riverside County Regional Park and Open Space District, with assistance from Riverside County TUMA (Transportation and Planning Departments, Riverside County Economic Development Agency, and other local, state, and federal recreational services agencies).

Note: Trails and bikeway maps are a graphic representation identifying the general location and classification of existing and proposed trails and bikeways in the unincorporated area of the County. All questions regarding precise alignment or improvement standards should be referred to the Riverside County Regional Park and Open Space District.





Note: Except for major regional facilities, trails and bikeways systems located within cities are generally not shown. Where trails and bikeways exist or are planned in the unincorporated area in such a manner that there are opportunities for connections with existing or planned trails and bikeways within adjacent cities, an arrow symbol is used to show the approximate location of the intended connection opportunity. The reader should contact the appropriate city for all information about that city's existing or planned trails and bikeways systems.

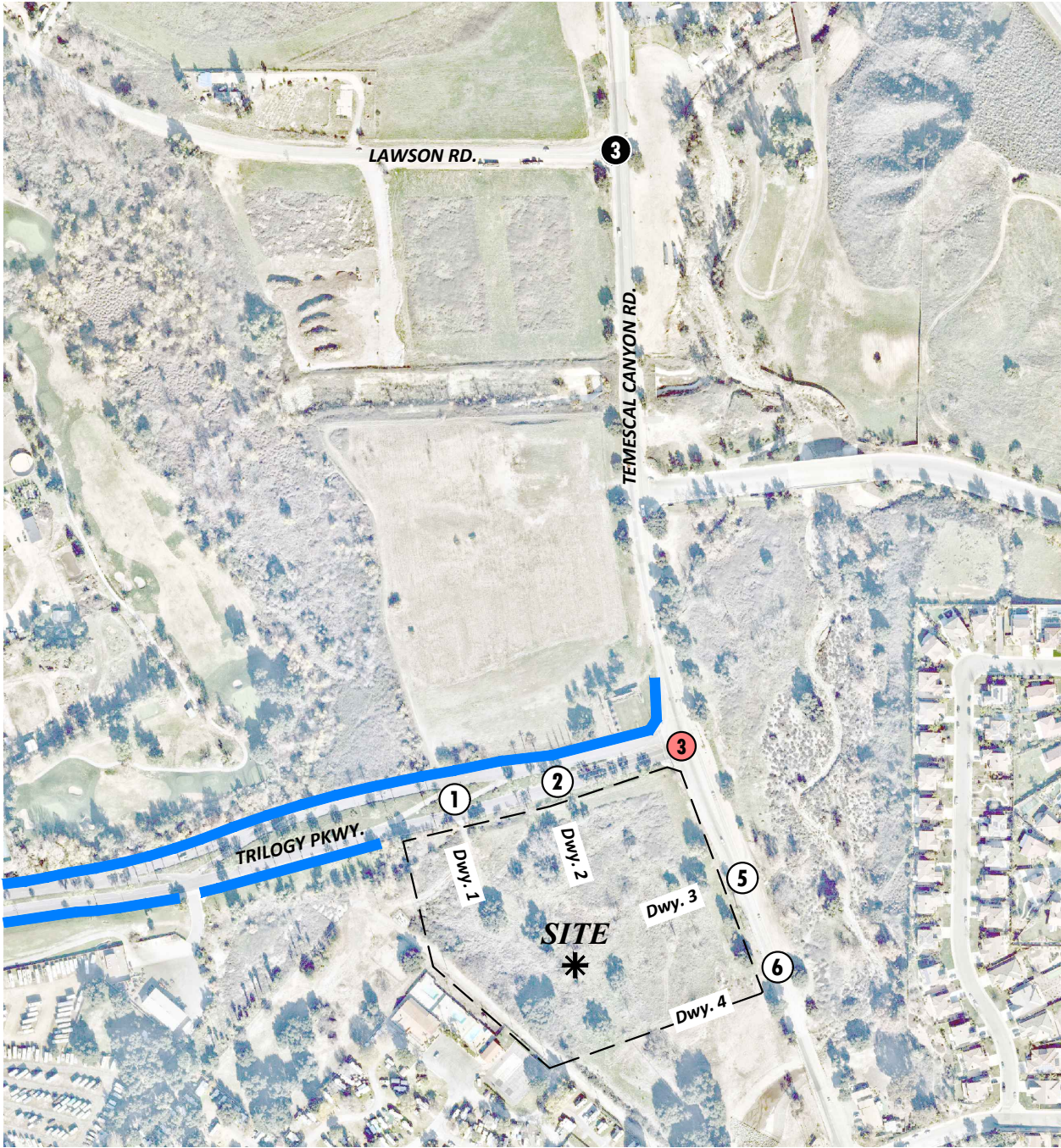

EXHIBIT 3-5: EXISTING PEDESTRIAN FACILITIES



**LEGEND:**

-  = SIDEWALK
-  = NO CROSSWALK
-  = FUTURE INTERSECTION
-  = CROSSWALK ON TWO APPROACHES



### 3.5 EXISTING TRAFFIC COUNTS

Based on direction from County staff, the intersection LOS analysis is based on the traffic volumes observed during the peak hour conditions using traffic count data collected in September 2018 and November 2019. The following peak hours were selected for analysis:

- Weekday AM Peak Hour (peak hour between 7:00 AM and 9:00 AM)
- Weekday PM Peak Hour (peak hour between 4:00 PM and 6:00 PM)

Due to the currently ongoing COVID-19 pandemic, schools and businesses within the study area were closed or operating at less than full capacity at the time this study was prepared. As such, historic (2018 and 2019) traffic counts were utilized in conjunction with a 2% per year growth rate (compounded annually) to reflect 2020 conditions. The 2018 and 2019 weekday AM and weekday PM peak hour count data is representative of typical weekday peak hour traffic conditions in the study area. There were no observations made in the field that would indicate atypical traffic conditions on the count dates as near-by schools were in session and operating on normal schedules. At the time traffic counts were being collected, near-by schools were in session and operating on normal schedules. Temescal Canyon Road was under construction at the time traffic counts were being collected. However, there were no roadway closures or detours. As such, there are no factors that would indicate reduced traffic volumes along Temescal Canyon Road.

The raw manual peak hour turning movement traffic count data sheets are included in Appendix 3.1. These raw turning volumes have been flow conserved between intersections with limited access, no access, and where there are currently no uses generating traffic. Existing weekday ADT volumes on arterial highways throughout the study area are shown on Exhibit 3-6. Where actual 24-hour tube count data was not available, Existing ADT volumes were based upon factored intersection peak hour counts collected by Urban Crossroads, Inc. using the following formula for each intersection leg:

$$\text{Weekday PM Peak Hour (Approach Volume + Exit Volume)} \times 16.16 = \text{Leg Volume}$$

A comparison of the PM peak hour and daily traffic volumes of various roadway segments within the study area indicated that the peak-to-daily relationship is approximately 6.19 percent. As such, the above equation utilizing a factor of 16.16 estimates the ADT volumes on the study area roadway segments assuming a peak-to-daily relationship of approximately 6.19 percent (i.e.,  $1/0.0619 = 16.16$ ) and was assumed to sufficiently estimate ADT volumes for planning-level analyses. Existing weekday AM and weekday PM peak hour intersection volumes are also shown on Exhibit 3-6.



**EXHIBIT 3-6: EXISTING (2020) TRAFFIC VOLUMES**



1	2	3	4	5	6
Dwy. 1 & Trilogy Pkwy.	Dwy. 2 & Trilogy Pkwy.	Temescal Canyon Rd. & Lawson Rd.	Temescal Canyon Rd. & Trilogy Pkwy.	Temescal Canyon Rd. & Dwy. 3	Temescal Canyon Rd. & Dwy. 4
Future Intersection	Future Intersection			Future Intersection	Future Intersection

**LEGEND:**

10(10) = AM(PM) PEAK HOUR INTERSECTION VOLUMES  
 10.0 = VEHICLES PER DAY (1000'S)



### **3.6 EXISTING (2020) INTERSECTION OPERATIONS ANALYSIS**

Existing peak hour traffic operations have been evaluated for the study area intersections based on the analysis methodologies presented in Section 2.2 *Intersection Capacity Analysis* of this report. The intersection operations analysis results are summarized in Table 3-1 which indicates that all of the study area intersections are currently operating at an acceptable LOS during the peak hours (i.e., LOS D or better). Consistent with Table 3-1, a summary of the peak hour intersection LOS for Existing conditions is shown on Exhibit 3-7. The intersection operations analysis worksheets are included in Appendix 3.2 of this TA.

### **3.7 EXISTING (2020) TRAFFIC SIGNAL WARRANTS ANALYSIS**

Traffic signal warrants for Existing traffic conditions are based on existing peak hour intersection turning volumes. The unsignalized study area intersection of Temescal Canyon Road and Lawson Road does not currently warrant a traffic signal for Existing (2020) traffic conditions. Existing conditions traffic signal warrant analysis worksheets are provided in Appendix 3.3.

### **3.8 RECOMMENDED IMPROVEMENTS**

All existing study area intersections currently operate at an acceptable LOS; therefore, no improvements are recommended for Existing (2020) traffic conditions.

Table 3-1

Intersection Analysis for Existing (2020) Conditions

#	Intersection	Traffic Control <sup>3</sup>	Intersection Approach Lanes <sup>1</sup>												Delay (secs.) <sup>2</sup>		Level of Service	
			Northbound			Southbound			Eastbound			Westbound			AM	PM	AM	PM
			L	T	R	L	T	R	L	T	R	L	T	R				
1	Driveway 1 & Trilogy Pkwy.		Future Intersection															
2	Driveway 2 & Trilogy Pkwy.		Future Intersection															
3	Temescal Canyon Rd. & Lawson Rd.	CSS	1	1	0	0	1	0	0	1	0	0	0	0	28.0	14.3	D	B
4	Temescal Canyon Rd. & Trilogy Pkwy.	TS	1	1	0	0	1	1	1	0	1	0	0	0	6.8	9.8	A	A
5	Temescal Canyon Rd. & Driveway 3		Future Intersection															
6	Temescal Canyon Rd. & Driveway 4		Future Intersection															

<sup>1</sup> When a right turn is designated, the lane can either be striped or unstriped. To function as a right turn lane there must be sufficient width for right turning vehicles to travel outside the through lanes.

L = Left; T = Through; R = Right

<sup>2</sup> Per the Highway Capacity Manual (6th Edition), overall average intersection delay and level of service are shown for intersections with a traffic signal or all way stop control. For intersections with cross street stop control, the delay and level of service for the worst individual movement (or movements sharing a single lane) are shown.





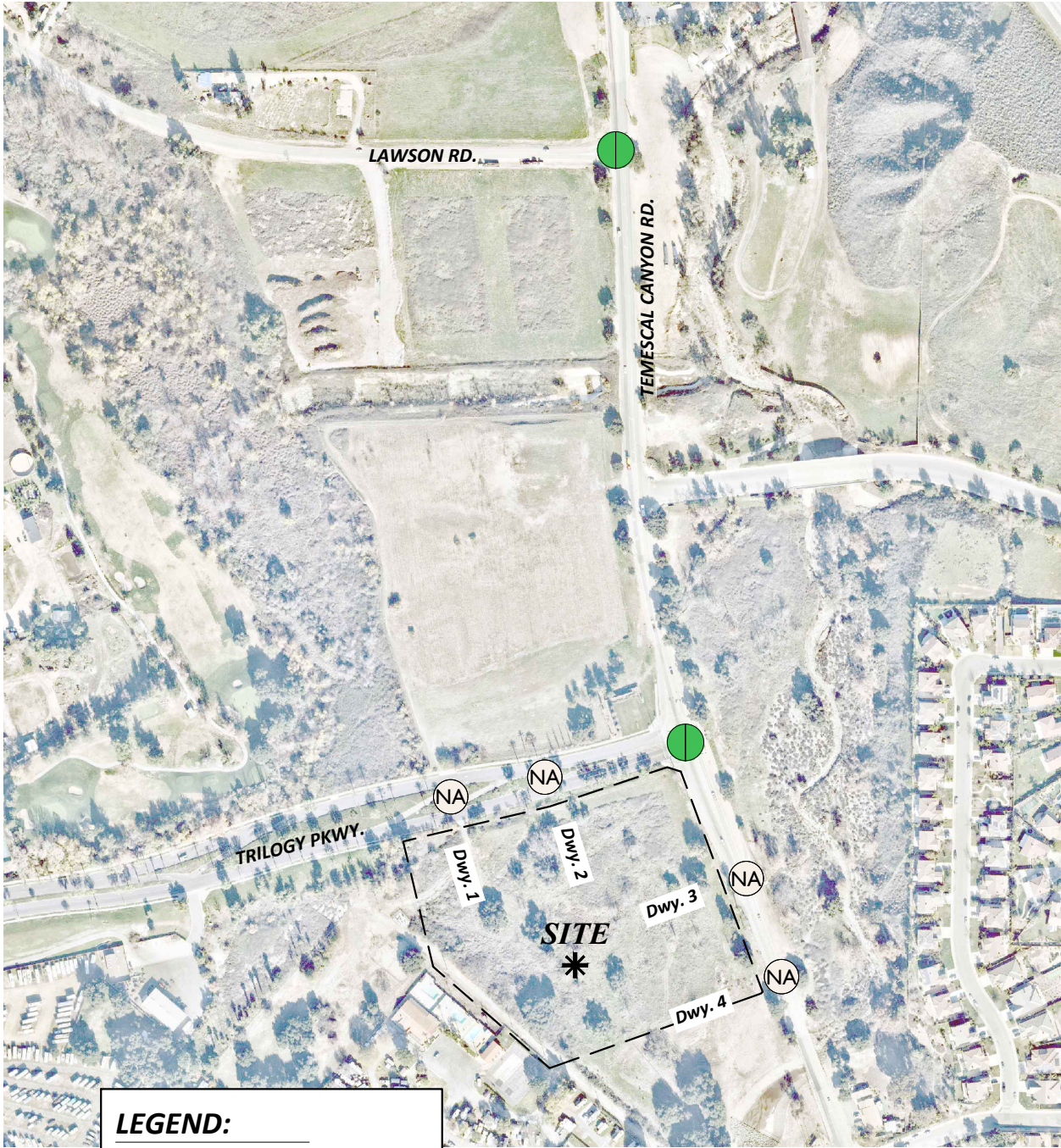

<sup>3</sup> CSS = Cross-street Stop; TS = Traffic Signal



EXHIBIT 3-7: EXISTING (2020) SUMMARY OF LOS



**LEGEND:**

-  = AM PEAK HOUR
-  = PM PEAK HOUR
-  = LOS A-D
-  = LOS E
-  = LOS F
-  = NOT AN ANALYSIS LOCATION FOR THIS SCENARIO



## 4 PROJECTED FUTURE TRAFFIC

This section presents the traffic volumes estimated to be generated by the Project's trip assignment onto the study area roadway network. The proposed Project consists of 144 assisted living dwelling units (112 standard assisted living dwelling units and 32 memory care dwelling units) and 76 senior adult housing attached dwelling units. Trip generation for the assisted living use will consist of 130 beds for the standard assisted living and 35 memory care beds for a total of 165 beds. Regional access to the Project site is available from the I-15 Freeway via Temescal Canyon Road.

### 4.1 PROJECT TRIP GENERATION

Trip generation represents the amount of traffic that is attracted and produced by a development and is based upon the specific land uses planned for a given project. Trip generation rates for the Project are shown in Table 4-1. The daily and peak hour trip generation summary for the Project are also shown in Table 4-1. These estimates are based on the trip-generation statistics published in the Institute of Transportation Engineers (ITE) Trip Generation Manual, (10<sup>th</sup> Edition, 2017). (3) For purposes of this analysis, the following ITE land use codes have been utilized:

- Senior Adult Housing (Attached, Independent Living) (ITE 252) – trip generation rates based on dwelling units
- Assisted Living (ITE 254) – trip generation rates based on total beds

The Project is estimated to generate a total of 712 trip-ends per day on a typical weekday, with approximately 46 AM peak hour trips and 63 PM peak hour trips (see Table 4-1).

### 4.2 PROJECT TRIP DISTRIBUTION

Trip distribution is the process of identifying the probable destinations, directions, or traffic routes that will be utilized by Project traffic. The potential interaction between the planned land uses and surrounding regional access routes are considered to identify the route where the Project traffic would distribute.

The Project trip distribution was developed based on anticipated travel patterns to and from the Project site and is consistent with other similar projects that have been reviewed and approved by County of Riverside staff. The Project trip distribution patterns were developed based on an understanding of existing travel patterns in the area, the geographical location of the site, and the site's proximity to the regional arterial and state highway system. These distribution patterns were reviewed by the County of Riverside as part of the traffic study scoping process (see Appendix 1.1).

Trip distribution patterns are shown on the following exhibits:

- Exhibit 4-1: Project (RIRO at Driveway 4) Trip Distribution
- Exhibit 4-2: Project (Full Access at Driveway 4) Trip Distribution

Table 4-1

Project Trip Generation Summary

Land Use	Units <sup>1</sup>	ITE LU Code	AM Peak Hour			PM Peak Hour			Daily
			In	Out	Total	In	Out	Total	
<b>Trip Generation Rates<sup>2</sup></b>									
Assisted Living	Beds	254	0.12	0.07	0.19	0.10	0.16	0.26	2.60
Senior Adult Housing - Attached	DU	252	0.07	0.13	0.20	0.14	0.12	0.26	3.70

Land Use	Quantity	Units <sup>1</sup>	AM Peak Hour			PM Peak Hour			Daily
			In	Out	Total	In	Out	Total	
<b>Project Trip Generation Summary</b>									
Assisted Living	165	Beds	20	12	31	17	26	43	430
Senior Adult Housing - Attached	76	DU	5	10	15	11	9	20	282
<b>Project Buildout Total:</b>			<b>25</b>	<b>21</b>	<b>46</b>	<b>27</b>	<b>36</b>	<b>63</b>	<b>712</b>

<sup>1</sup> DU = Dwelling Units

<sup>2</sup> Trip Generation Source: Institute of Transportation Engineers (ITE), Trip Generation Manual, Tenth Edition (2017).



**EXHIBIT 4-1: PROJECT (RIRO AT DRIVEWAY 4) TRIP DISTRIBUTION**

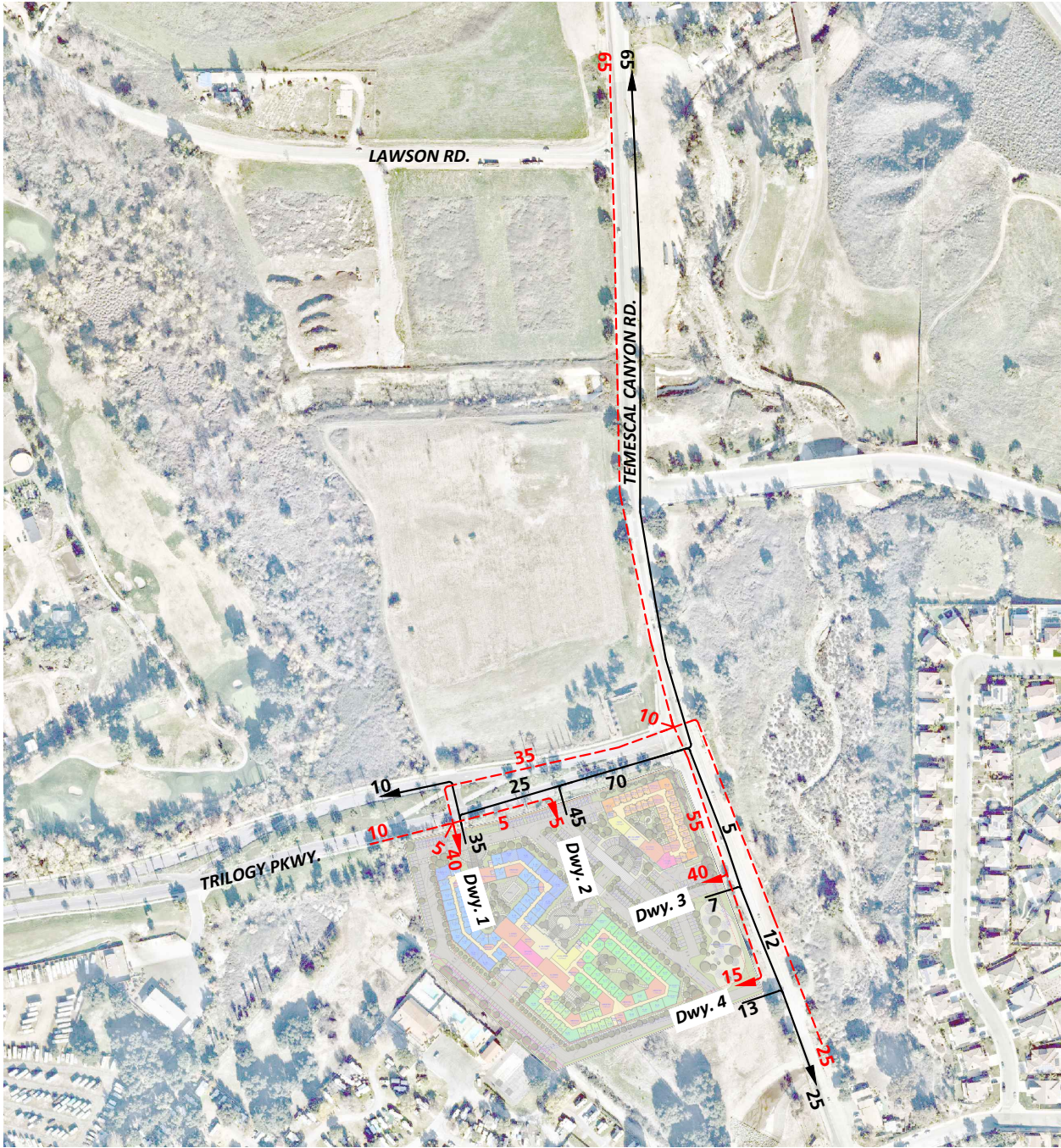

**LEGEND:**

- 10 = PERCENT TO/FROM PROJECT
- ← = OUTBOUND
- ← - - - = INBOUND



**EXHIBIT 4-2: PROJECT (FULL ACCESS AT DRIVEWAY 4) TRIP DISTRIBUTION**

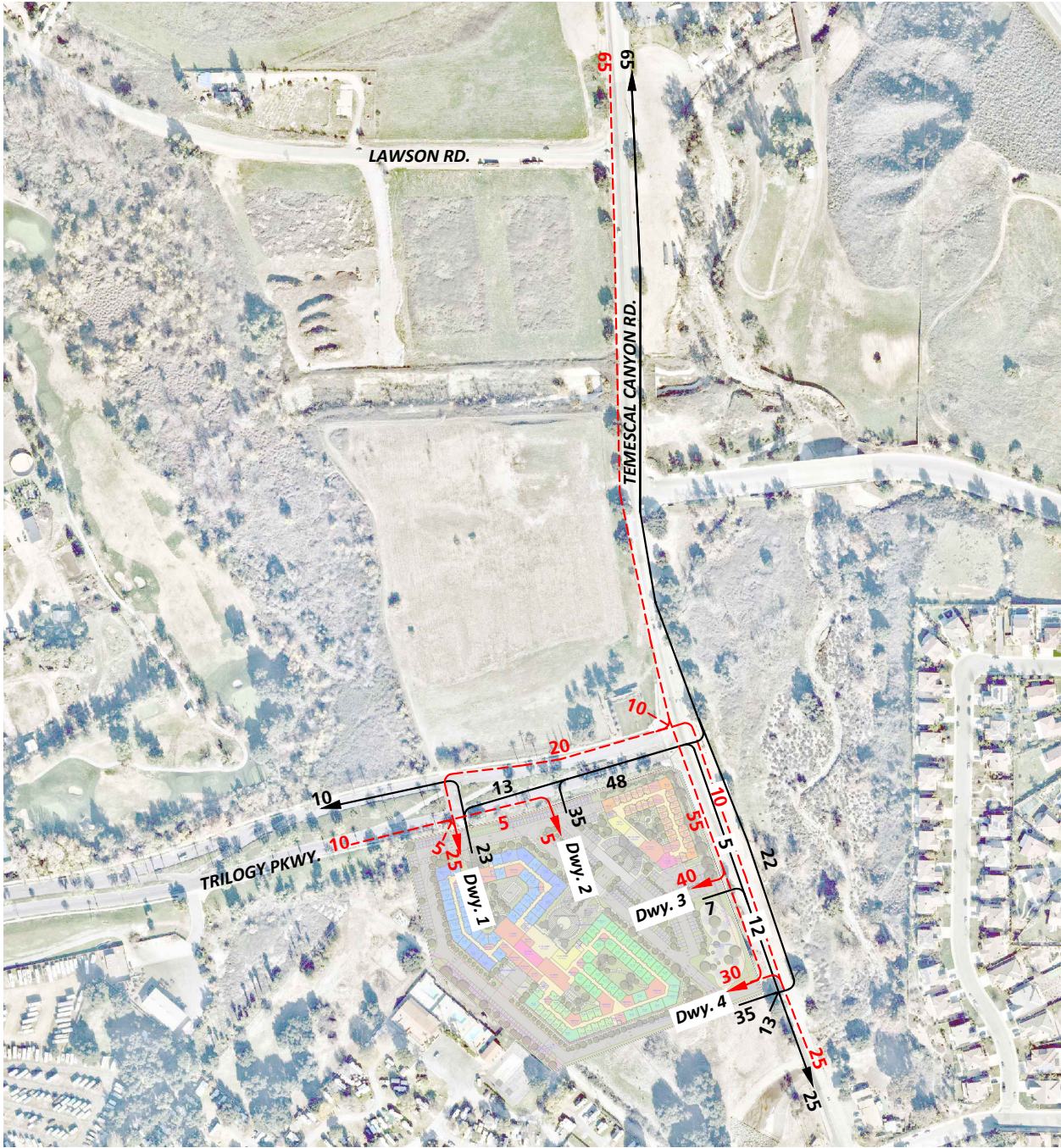

**LEGEND:**

- 10 = PERCENT TO/FROM PROJECT
- ← = OUTBOUND
- ← (red dashed) = INBOUND





### 4.3 MODAL SPLIT

The traffic reducing potential of public transit, walking, or bicycling have not been considered in this TA. Essentially, the traffic projections are "conservative" in that these alternative travel modes might be able to reduce the forecasted traffic volumes (employee trips only).

### 4.4 PROJECT TRIP ASSIGNMENT

The assignment of traffic from the Project area to the adjoining roadway system is based upon the Project trip generation, trip distribution, and the arterial highway and local street system improvements that would be in place by the time of initial occupancy of the Project. Based on the identified Project traffic generation and trip distribution patterns, Project ADT and peak hour intersection turning movement volumes with right-in/right-out access at Driveway 4 are shown on Exhibit 4-3. Project ADT and peak hour intersection turning movement volumes with full access at Driveway 4 are shown on Exhibit 4-4.

### 4.5 BACKGROUND TRAFFIC

Future year traffic forecasts have been based upon a background (ambient) growth factor of 2% per year for 2023 traffic conditions. The ambient growth factor is intended to approximate traffic growth. The total ambient growth is 6.12% for 2023 traffic conditions (compounded growth of 2 percent per year over 3 years). This ambient growth rate is added to existing traffic volumes to account for area-wide growth not reflected by cumulative development projects.

Ambient growth has been added to daily and peak hour traffic volumes on surrounding roadways, in addition to traffic generated by the development of future projects that have been approved but not yet built and/or for which development applications have been filed and are under consideration by governing agencies.

The currently adopted Southern California Association of Governments (SCAG) 2020 Regional Transportation Plan/Sustainable Communities Strategy (RTP/SCS) (May 2020) growth forecasts for the County of Riverside identifies projected growth in population of 370,500 in 2016 to 525,600 in 2045, or a 41.9 percent increase over the 29-year period. (8) The change in population equates to roughly a 1.21 percent growth rate, compounded annually. Similarly, growth over the same 29-year period in households is projected to increase by 59.2 percent, or 1.62 percent annual growth rate. Finally, growth in employment over the same 29-year period is projected to increase by 83.4 percent, or a 2.11 percent annual growth rate.

**EXHIBIT 4-3: PROJECT (RIRO AT DRIVEWAY 4) TRAFFIC VOLUMES**



1	2	3	4	5	6
Dwy. 1 & Trilogy Pkwy.	Dwy. 2 & Trilogy Pkwy.	Temescal Canyon Rd. & Lawson Rd.	Temescal Canyon Rd. & Trilogy Pkwy.	Temescal Canyon Rd. & Dwy. 3	Temescal Canyon Rd. & Dwy. 4

**LEGEND:**

10(10) = AM(PM) PEAK HOUR INTERSECTION VOLUMES  
 10.0 = VEHICLES PER DAY (1000'S)





**EXHIBIT 4-4: PROJECT (FULL ACCESS AT DRIVEWAY 4) TRAFFIC VOLUMES**



1	2	3	4	5	6
Dwy. 1 & Trilogy Pkwy.	Dwy. 2 & Trilogy Pkwy.	Temescal Canyon Rd. & Lawson Rd.	Temescal Canyon Rd. & Trilogy Pkwy.	Temescal Canyon Rd. & Dwy. 3	Temescal Canyon Rd. & Dwy. 4

**LEGEND:**

10(10) = AM(PM) PEAK HOUR INTERSECTION VOLUMES  
 10.0 = VEHICLES PER DAY (1000'S)



## 4.6 CUMULATIVE DEVELOPMENT TRAFFIC

A cumulative project list was developed for the purposes of this analysis through consultation with planning and engineering staff from the County of Riverside. The cumulative project list includes known and foreseeable projects that are anticipated to contribute traffic to the study area intersections. Where applicable, cumulative projects anticipated to contribute measurable traffic (i.e. 50 or more peak hour trips) to study area intersections have been manually added to the study area network to generate EAPC forecasts. In other words, this list of cumulative development projects has been reviewed to determine which projects would likely contribute measurable traffic through the study area intersections (e.g., those cumulative projects in close proximity to the proposed Project). For the purposes of this analysis, the cumulative projects that were determined to affect one or more of the study area intersections are shown on Exhibit 4-5, listed in Table 4-2, and have been considered for inclusion.

Although it is unlikely that all of these cumulative projects would be fully built and occupied by Year 2023, they have been included in an effort to conduct a conservative analysis and overstate as opposed to understate potential traffic deficiencies. Any other cumulative projects located beyond the cumulative study area that are not expected to contribute measurable traffic to study area intersections have not been included since the traffic would dissipate due to the distance from the Project site and study area intersections. Any additional traffic generated by other projects not on the cumulative projects list is accounted for through background ambient growth factors that have been applied to the peak hour volumes at study area intersections as discussed in Section 4.5 *Background Traffic*. Cumulative ADT and peak hour intersection turning movement volumes are shown Exhibit 4-6.

## 4.7 NEAR-TERM TRAFFIC CONDITIONS

The “buildup” approach combines existing traffic counts with a background ambient growth factor to forecast EAP (2023) and EAPC (2023) traffic conditions. An ambient growth factor of 6.12% accounts for background (area-wide) traffic increases that occur over time up to the year 2023 from the year 2020 (2.0 percent per year growth rate, compounded over a 3-year period). Traffic volumes generated by the Project are then added to assess the near-term traffic conditions. The 2023 roadway network is similar to the Existing conditions roadway network, with the exception of future driveways proposed to be developed by the Project.



**EXHIBIT 4-5: CUMULATIVE DEVELOPMENT PROJECTS LOCATION MAP**

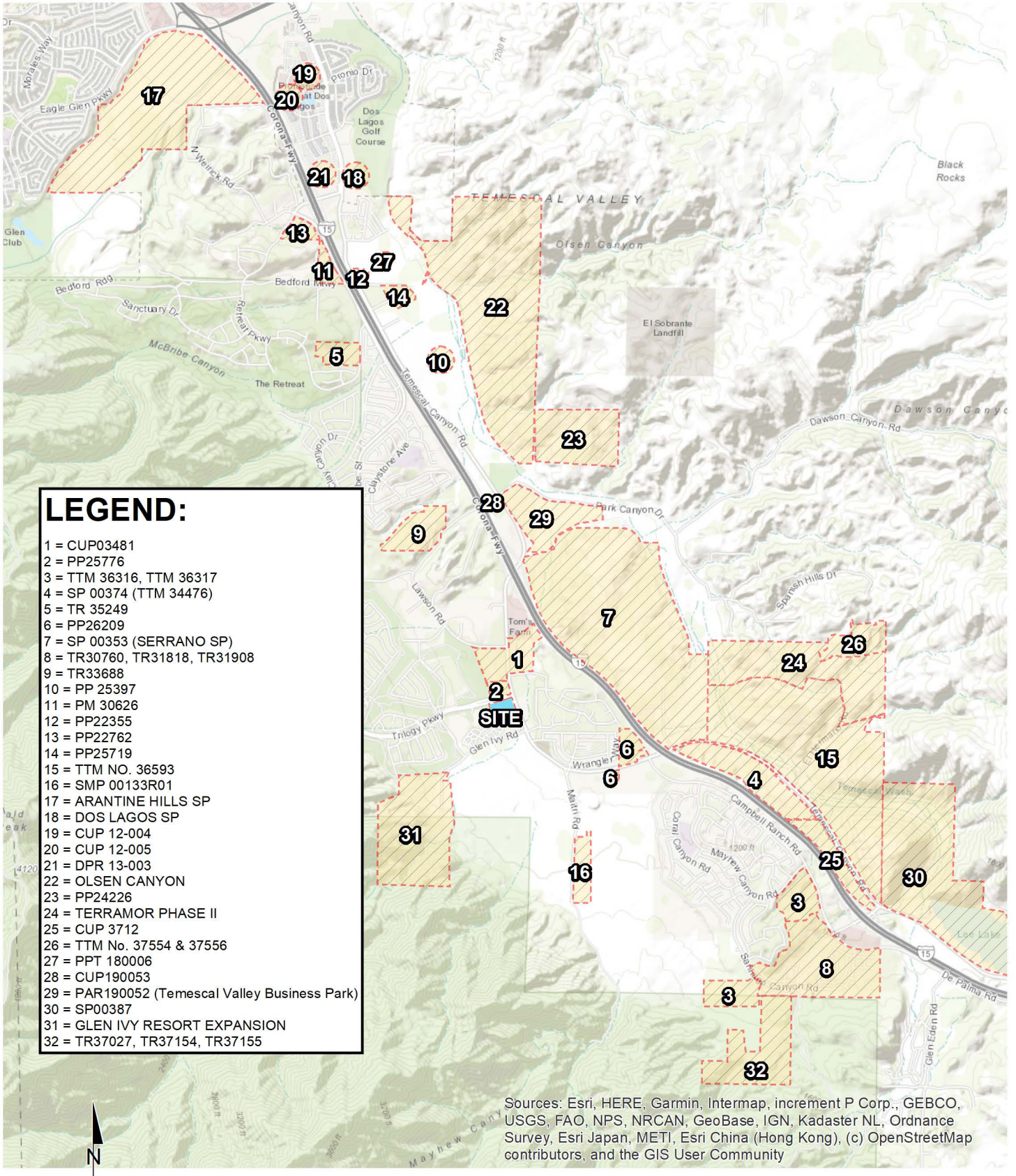



**EXHIBIT 4-6: CUMULATIVE DEVELOPMENT TRAFFIC VOLUMES**



1	2	3	4	5	6
Dwy. 1 & Trilogy Pkwy.	Dwy. 2 & Trilogy Pkwy.	Temescal Canyon Rd. & Lawson Rd.	Temescal Canyon Rd. & Trilogy Pkwy.	Temescal Canyon Rd. & Dwy. 3	Temescal Canyon Rd. & Dwy. 4
Future Intersection	Future Intersection			Future Intersection	Future Intersection

**LEGEND:**

10(10) = AM(PM) PEAK HOUR INTERSECTION VOLUMES  
 10.0 = VEHICLES PER DAY (1000'S)



**Table 4-2**  
Page 1 of 2

**Cumulative Development Land Use Summary**

#	Project Name	Land Use	Quantity	Units <sup>1</sup>
1	CUP03481	Shopping Center	480.000	TSF
2	PP25776	Church	49.000	TSF
		Private School	216	STU
		Pre-School	96	STU
3	TTM No. 36316	Single Family Residential	87	DU
	TTM No. 36317	Single Family Residential	194	DU
		Passive Park	14.5	AC
		Passive Park	3.9	AC
4	Specific Plan No. 00374 (TTM No. 34476) <sup>2</sup>	Fast Food w/ Drive Thru	3.500	TSF
		Business Park	476.150	TSF
		High Turnover Restaurant	13.460	TSF
		Daycare Center	10.000	TSF
		Hotel	320	ROOMS
		Shopping Center	117.740	TSF
		General Office	103.300	TSF
		Mini-Warehouse	381	UNITS
5	TR 35249	SFDR	53	DU
6	PP26209	Multi-Family Residential	80	DU
7	Specific Plan No. 00353 (Serrano Specific Plan) <sup>3</sup>	Light Industrial	6,600.994	TSF
		Shopping Center	172.150	TSF
8	TR30760	Single Family Residential	285	DU
	TR31818	Single Family Residential	311	DU
		Community Park	11.65	AC
	TR31908	Single Family Residential	261	DU
9	TR33688	Single Family Residential	54	DU
10	PP 25397	Manufacturing	60.300	TSF
11	PM 30626	Business Park	8.7	AC
12	PP22355	Fast Food w/ Drive Thru	2.500	TSF
		Retail	30.214	TSF
13	PP22762	General Office	93.924	TSF
14	PP25719	General Light Industrial	84.892	TSF
15	Specific Plan No. 00327 (Toscana Phase I and Phase III)	SFDR	917	DU
		Active Park	8.1	AC
16	SMP 139R1 (CUP 03679)	Surface Mining	2.0	MTPY
17	Arantine Hills Specific Plan	Single Family Residential	549	DU
		Multi-Family Residential	1,072	DU
		Passive Park	4.0	AC
		Active Park	11.0	AC
		General Office	59.000	TSF
		Business Park	230.900	TSF
		Specialty Retail	59.000	TSF
		Shopping Center	396.400	TSF
18	Dos Lagos Specific Plan	Apartments (PA 1)	450	DU
19	CUP 12-004	Hotel	120	RM
20	CUP 12-005	Apartments	125	DU

**Table 4-2**  
Page 2 of 2

**Cumulative Development Land Use Summary**

#	Project Name	Land Use	Quantity	Units <sup>1</sup>
21	DPR 13-003	Apartments	354	DU
22	Olsen Canyon	Surface Mining	2.0	MTPY
23	PP24226 (Leinen Business Park)	Manufacturing	135.421	TSF
24	Toscana Phase 2	Single Family Residential	501	DU
		Active Park	5.0	AC
		Passive Park	0.9	AC
25	CUP 3712 (Phase 1 + Phase 2)	Gas Station w/ Market and Car Wash	12	DU
		Fast Food w/ Drive Thru	6.800	TSF
		High Turnover Restaurant	20.000	TSF
		General Office	56.000	TSF
		Shopping Center	46.900	TSF
		Supermarket	43.000	TSF
		Pharmacy w/ Drive Thru	14.000	TSF
	Bank w/ Drive Thru	3.500	TSF	
26	TTM No. 37554 & 37556	Single Family Residential	143	DU
27	PPT180006	Warehousing	30.250	TSF
28	CUP190053	Marijuana Dispensary	8.582	TSF
29	PAR190052 (Temescal Valley Business Park)	Industrial Park	1025.766	TSF
		Fast Food w/ Drive Thru	5.400	TSF
		Super Convenience Market/Gas Station	16	VFP
30	SP 00387 (Lakeside)	Single Family Residential	410	DU
31	Glen Ivy Resort Expansion	Single Family Residential	62	DU
		Multi-Family Residential	203	DU
		Resort Hotel	210	RM
		Shopping Center	122.729	TSF
32	TR37027, TR37154 & TR37155	Single Family Residential	116	DU

<sup>1</sup> DU = Dwelling Units; TSF = Thousand Square Feet; AC = Acres; MTPY = Million Tons Per Year; STU = Students; RM = Room

<sup>2</sup> Land Use and Quantity Source: Specific Plan No. 00374 (TTM No. 34476) TIA, Urban Crossroads, Inc., August 18, 2008.

<sup>3</sup> Source: Serrano Commerce Center TIA, Kunzman Associates, November 20, 2008.



The near-term traffic analysis includes the following traffic conditions, with the various traffic components:

- Existing Plus Ambient Growth Plus Project (2023)
  - Existing 2020 counts
  - Ambient growth traffic (6.12%)
  - Project traffic
- Existing Plus Ambient Growth Plus Project Plus Cumulative (2023)
  - Existing 2020 counts
  - Ambient growth traffic (6.12%)
  - Cumulative Development traffic
  - Project traffic

#### **4.8 HORIZON YEAR (2040) VOLUME DEVELOPMENT**

“Buildout” traffic projections for Horizon Year conditions are based on traffic model forecasts and were derived from the RivTAM using accepted procedures for model forecast refinement and smoothing for study area intersections located within the County of Riverside. The Horizon Year traffic conditions analyses was utilized to determine if improvements funded through regional transportation mitigation fee programs, such as the TUMF, can accommodate the long-range traffic at the target LOS identified in the County of Riverside General Plan.

The traffic forecasts reflect the area-wide growth anticipated between Existing (2020) conditions and Horizon Year (2040) traffic conditions. In most instances the traffic model zone structure is not designed to provide accurate turning movements along arterial roadways unless refinement and reasonableness checking is performed. Therefore, the Horizon Year peak hour forecasts were refined using the model derived long range forecasts, base (validation) year model forecasts, along with existing peak hour traffic count data collected at each analysis location in September 2018 and November 2019. The RivTAM has a base (validation) year of 2012 and a horizon (future forecast) year of 2040. The RivTAM 2040 model utilized for the purposes of this analysis assumes buildout of the County of Riverside.

The refined future peak hour approach and departure volumes obtained from the model output data are then entered into a spreadsheet program consistent with the National Cooperative Highway Research Program (NCHRP Report 255), along with initial estimates of turning movement proportions. A linear programming algorithm is used to calculate individual turning movements which match the known directional roadway segment forecast volumes computed in the previous step. This program computes a likely set of intersection turning movements from intersection approach counts and the initial turning proportions from each approach leg.

Typically, the model growth is prorated and is subsequently added to the existing (base validation) traffic volumes to represent Horizon Year traffic conditions. In an effort to conduct a conservative analysis, reductions to traffic forecasts from either Existing, EAP, and EAPC traffic conditions were not assumed as part of this analysis. As such, in conjunction with the addition of cumulative projects that are not consistent with the General Plan, additional growth has also been applied on a movement-by-movement basis, where applicable, to estimate reasonable

Horizon Year forecasts. Horizon Year turning volumes were compared to EAPC (2023) volumes in order to ensure a minimum growth as a part of the refinement process. The minimum growth includes any additional growth between EAPC (2023) and Horizon Year (2040) traffic conditions that is not accounted for by the traffic generated by cumulative development projects and ambient growth rates assumed between Existing (2020) and EAPC (2023) conditions.

Future estimated peak hour traffic data was used for new intersections and intersections with an anticipated change in travel patterns (i.e., the future Temescal Canyon Road extension) to further refine the Horizon Year (2040) peak hour forecasts.

The future Horizon Year (2040) Without Project peak hour turning movements were then reviewed by Urban Crossroads, Inc. for reasonableness, and in some cases, were adjusted to achieve flow conservation, reasonable growth, and reasonable diversion between parallel routes. Flow conservation checks ensure that traffic flow between two closely spaced intersections, such as two adjacent driveway locations, is verified in order to make certain that vehicles leaving one intersection are entering the adjacent intersection and that there is no unexplained loss of vehicles. The result of this traffic forecasting procedure is a series of traffic volumes which are suitable for traffic operations analysis. Post-processing worksheets for Horizon Year (2040) Without Project traffic conditions are provided in Appendix 4.1.

## 5 EAP (2023) TRAFFIC CONDITIONS

This section discusses the methods used to develop EAP (2023) traffic forecasts, and the resulting intersection operations and traffic signal warrant analyses.

### 5.1 ROADWAY IMPROVEMENTS

The lane configurations and traffic controls assumed to be in place for EAP (2023) conditions are consistent with those shown previously on Exhibit 3-1, with the exception of the following:

- Project driveways and those facilities assumed to be constructed by the Project to provide site access are also assumed to be in place for EAP conditions only (e.g., intersection and roadway improvements at the Project's frontage and driveways).

### 5.2 EAP (2023) TRAFFIC VOLUME FORECASTS

This scenario includes adjusted Existing (2020) traffic volumes plus an ambient growth factor of 6.12% and the addition of Project traffic. The weekday ADT volumes and peak hour volumes which can be expected for EAP (2023) traffic conditions are shown on Exhibit 5-1 with right-in/right-out access at Driveway 4. Exhibit 5-2 shows the weekday ADT and peak hour volumes which can be expected for EAP (2023) traffic conditions with full access at Driveway 4.

### 5.3 INTERSECTION OPERATIONS ANALYSIS

LOS calculations were conducted for the study intersections to evaluate their operations under EAP conditions with roadway and intersection geometrics consistent with Section 5.1 *Roadway Improvements*. As shown in Table 5-1, all study area intersections are anticipated to continue to operate at an acceptable LOS during the peak hours for EAP (2023) traffic conditions with both right-in/right-out and full access at Driveway 4, consistent with Existing (2020) traffic conditions. A summary of the peak hour intersection LOS for EAP (2023) traffic conditions are shown on Exhibits 5-3 and 5-4 for right-in/right-out and full access at Driveway 4. The intersection operations analysis worksheets for EAP (2023) traffic conditions are included in Appendix 5.1 for right-in/right-out access at Driveway 4 and Appendix 5.2 for full access at Driveway 4.

### 5.4 TRAFFIC SIGNAL WARRANTS ANALYSIS

Traffic signal warrants have been performed (based on CA MUTCD) for EAP (2023) traffic conditions based on peak hour volumes for existing intersections and projected daily traffic volumes for future (driveway) intersections. There are no study area intersections anticipated to meet planning-level ADT traffic signal warrants under EAP (2023) traffic conditions (see Appendix 5.3).

**EXHIBIT 5-1: EAP (2023-RIRO AT DRIVEWAY 4) TRAFFIC VOLUMES**



1	2	3	4	5	6
Dwy. 1 & Trilogy Pkwy.	Dwy. 2 & Trilogy Pkwy.	Temescal Canyon Rd. & Lawson Rd.	Temescal Canyon Rd. & Trilogy Pkwy.	Temescal Canyon Rd. & Dwy. 3	Temescal Canyon Rd. & Dwy. 4
<p>← 86(123) 9(9)</p> <p>58(189) 1(1)</p> <p>2(4) 5(9)</p>	<p>← 95(132)</p> <p>62(197) 1(1)</p> <p>9(16)</p>	<p>← 35(78) 363(593)</p> <p>59(40) 10(22)</p> <p>102(29) 1100(465)</p>	<p>← 51(87) 322(528)</p> <p>52(171) 20(42)</p> <p>44(46) 1151(323)</p>	<p>← 10(11) 333(559)</p> <p>1(3)</p> <p>1195(369)</p>	<p>← 4(4) 331(557)</p> <p>3(5)</p> <p>1195(369)</p>

**LEGEND:**

10(10) = AM(PM) PEAK HOUR INTERSECTION VOLUMES  
 10.0 = VEHICLES PER DAY (1000'S)





**EXHIBIT 5-2: EAP (2023-FULL ACCESS AT DRIVEWAY 4) TRAFFIC VOLUMES**



1	2	3	4	5	6
Dwy. 1 & Trilogy Pkwy.	Dwy. 2 & Trilogy Pkwy.	Temescal Canyon Rd. & Lawson Rd.	Temescal Canyon Rd. & Trilogy Pkwy.	Temescal Canyon Rd. & Dwy. 3	Temescal Canyon Rd. & Dwy. 4
58(189) 1(1) 2(4) 3(5) ← 86(123) 5(5)	60(193) 1(1) 7(13) ← 91(128)	59(40) 10(22) 102(29) 1100(465) ← 35(78) 363(593)	47(163) 20(42) 41(42) 1156(331) ← 51(87) 322(528)	1(3) 1196(373) ← 10(11) 333(559)	5(8) 3(5) 4(4) 1192(365) ← 4(4) 331(557)

**LEGEND:**

10(10) = AM(PM) PEAK HOUR INTERSECTION VOLUMES  
 10.0 = VEHICLES PER DAY (1000'S)





EXHIBIT 5-3: EAP (2023-RIRO AT DRIVEWAY 4) SUMMARY OF LOS

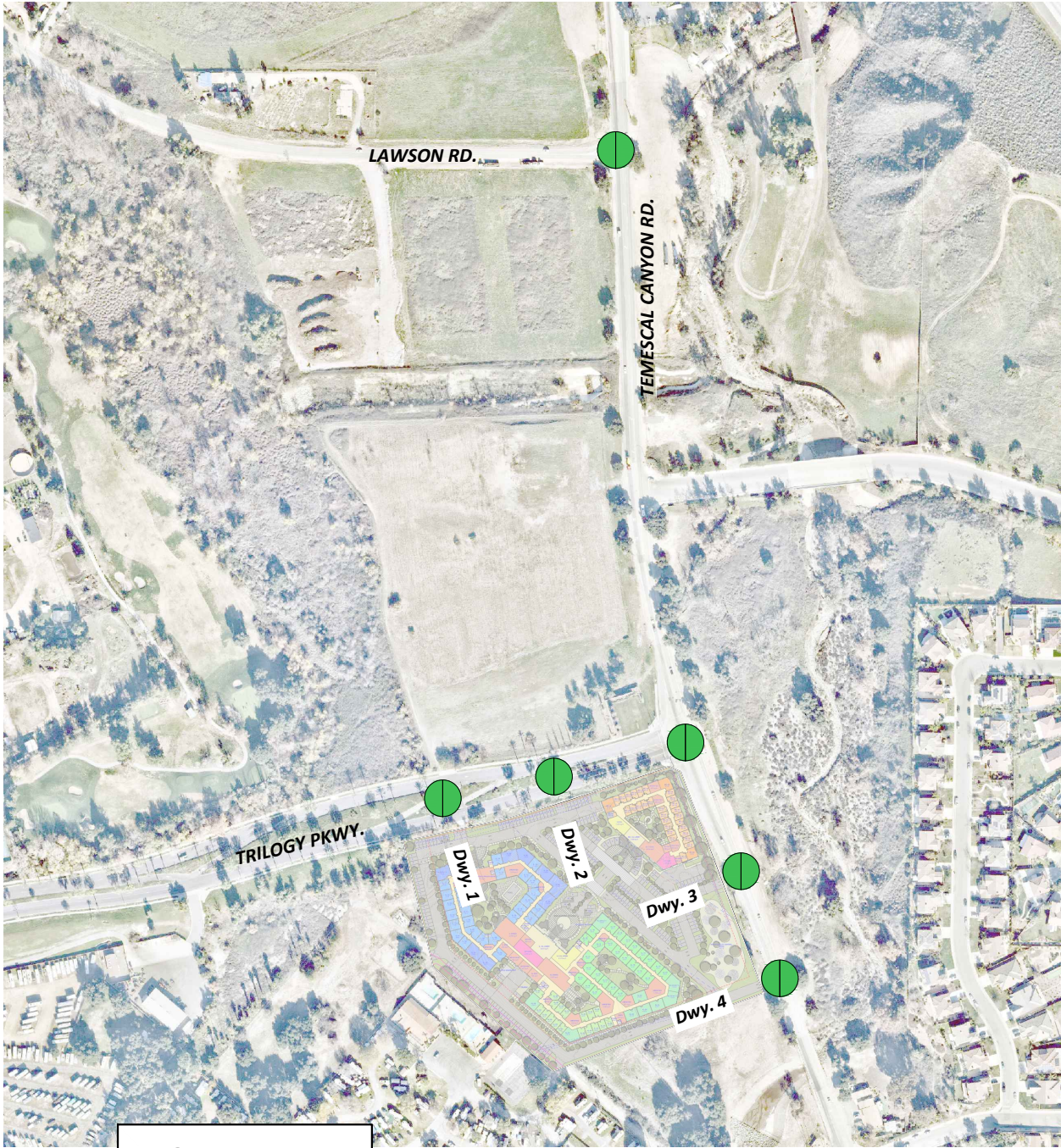

**LEGEND:**





-  = AM PEAK HOUR
-  = PM PEAK HOUR
-  = LOS A-D
-  = LOS E
-  = LOS F





EXHIBIT 5-4: EAP (2023-FULL ACCESS AT DRIVEWAY 4) SUMMARY OF LOS

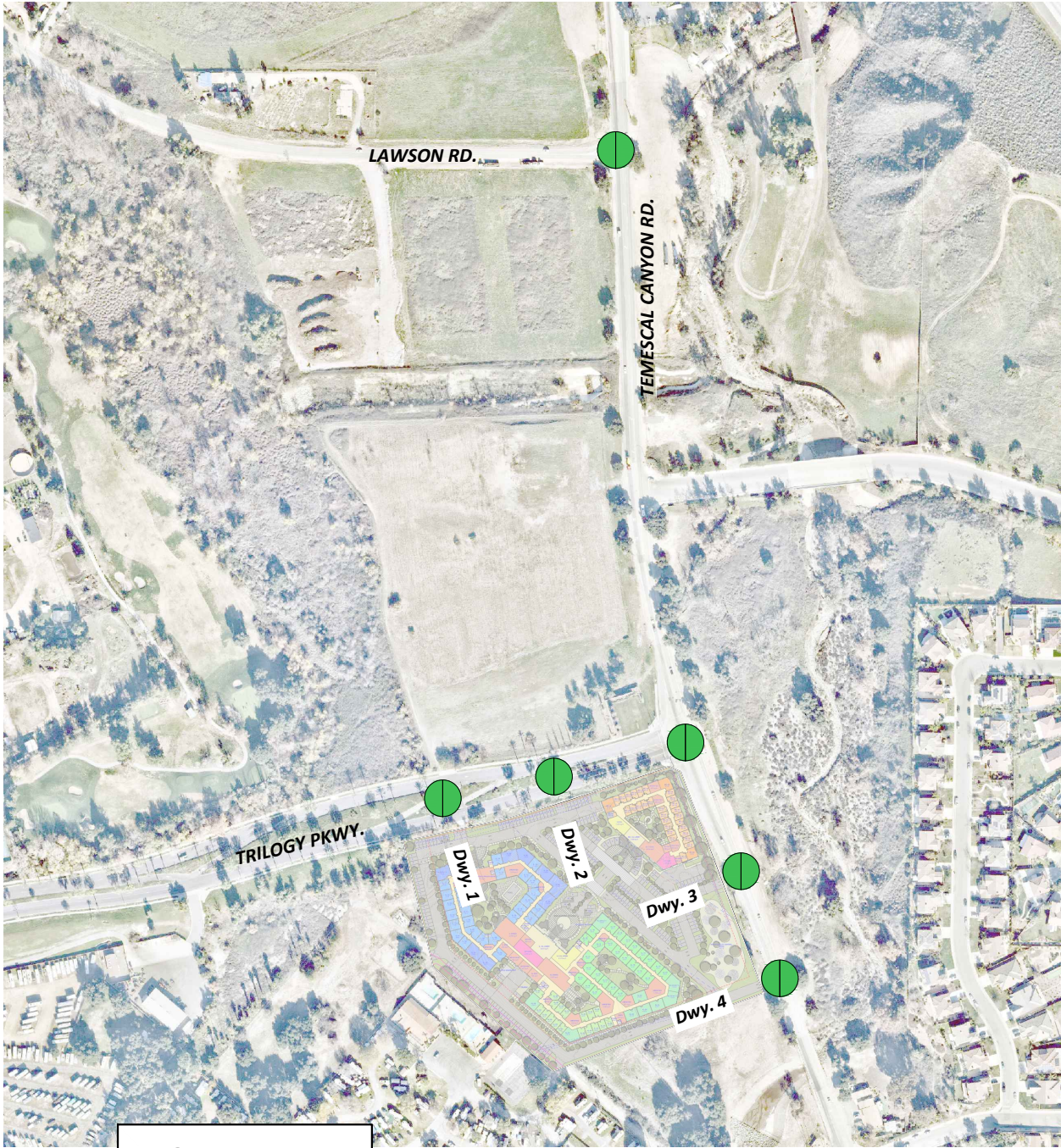

**LEGEND:**





-  = AM PEAK HOUR
-  = PM PEAK HOUR
-  = LOS A-D
-  = LOS E
-  = LOS F



Table 5-1

Intersection Analysis for EAP (2023) Conditions

#	Intersection	Traffic Control <sup>2</sup>	EAP (2023) - RIRO <sup>3</sup>				EAP (2023) - FULL <sup>4</sup>			
			Delay <sup>1</sup> (secs.)		Level of Service		Delay <sup>1</sup> (secs.)		Level of Service	
			AM	PM	AM	PM	AM	PM	AM	PM
1	Driveway 1 & Trilogy Pkwy.	<u>CSS</u>	8.7	9.4	A	A	8.8	9.5	A	A
2	Driveway 2 & Trilogy Pkwy.	<u>CSS</u>	8.5	8.9	A	A	8.5	8.9	A	A
3	Temescal Canyon Rd. & Lawson Rd.	CSS	33.2	15.3	D	C	No Change			
4	Temescal Canyon Rd. & Trilogy Pkwy.	TS	9.2	10.5	A	B	8.9	10.3	A	B
5	Temescal Canyon Rd. & Driveway 3	<u>CSS</u>	10.3	12.3	B	B	10.3	12.3	B	B
6	Temescal Canyon Rd. & Driveway 4	<u>CSS</u>	10.3	12.3	B	B	29.3	16.6	D	C

<sup>1</sup> Per the Highway Capacity Manual (6th Edition), overall average intersection delay and level of service are shown for intersections with a traffic signal or all way stop control. For intersections with cross street stop control, the delay and level of service for the worst individual movement (or movements sharing a single lane) are shown.

<sup>2</sup> CSS = Cross-street Stop; TS = Traffic Signal; CSS = Improvement

<sup>3</sup> LOS results assuming right-in/right-out access only at Driveway 4 on Temescal Canyon Road.

<sup>4</sup> LOS results assuming full access only at Driveway 4 on Temescal Canyon Road.

## 6.5 RECOMMENDED IMPROVEMENTS

All study area intersections are anticipated to continue to operate at an acceptable LOS under EAP (2023) traffic conditions. As such, no improvements have been recommended.



This Page Intentionally Left Blank

## 6 EAPC (2023) TRAFFIC CONDITIONS

This section discusses the methods used to develop EAPC (2023) traffic forecasts, and the resulting intersection operations and traffic signal warrant analyses.

### 6.1 ROADWAY IMPROVEMENTS

The lane configurations and traffic controls assumed to be in place for EAPC (2023) conditions are consistent with those shown previously on Exhibit 3-1, with the exception of the following:

- Project driveways and those facilities assumed to be constructed by the Project to provide site access are also assumed to be in place for EAPC conditions only (e.g., intersection and roadway improvements along the Project's frontage and driveways).
- Driveways and those facilities assumed to be constructed by cumulative developments to provide site access are also assumed to be in place for EAPC (2023) conditions only (e.g., intersection and roadway improvements along the cumulative development's frontages).

### 6.2 EAPC (2023) TRAFFIC VOLUME FORECASTS

To account for background traffic, other known cumulative development projects in the study area were included in addition to 6.12% of ambient growth for EAPC (2023) traffic conditions in conjunction with traffic associated with the proposed Project. The weekday ADT volumes and peak hour volumes which can be expected for EAPC (2023) traffic conditions with right-in/right-out access at Driveway 4 are shown on Exhibit 6-1. The weekday ADT volumes and peak hour volumes which can be expected for EAPC (2023) traffic conditions with full access at Driveway 4 are shown on Exhibit 6-2.

### 6.3 INTERSECTION OPERATIONS ANALYSIS

LOS calculations were conducted for the study intersections to evaluate their operations under EAPC (2023) conditions with roadway and intersection geometrics consistent with Section 6.1 *Roadway Improvements*. As shown in Table 6-1, the following study area intersection is anticipated to operate at an unacceptable LOS (i.e., LOS E or worse) during the peak hours under EAPC (2023) traffic conditions with right-in/right-out access at Driveway 4:

- Temescal Canyon Road & Lawson Road (#3) – LOS F AM and PM peak hours

The following additional study area intersection is anticipated to operate at an unacceptable LOS (i.e., LOS E or worse) during the peak hours under EAPC (2023) traffic conditions with full access at Driveway 4:

- Temescal Canyon Road & Driveway 4 (#6) – LOS F AM peak hour only

A summary of the peak hour intersection LOS for EAPC (2023) traffic conditions are shown on Exhibits 6-3 and 6-4 for right-in/right-out and full access at Driveway 4. The intersection operations analysis worksheets for EAPC (2023) traffic conditions are included in Appendices 6.1 and 6.2, respectively, for right-in/right-out and full access at Driveway 4.

**EXHIBIT 6-1: EAPC (2023-RIRO AT DRIVEWAY 4) TRAFFIC VOLUMES**



1	2	3	4	5	6
Dwy. 1 & Trilogy Pkwy.	Dwy. 2 & Trilogy Pkwy.	Temescal Canyon Rd. & Lawson Rd.	Temescal Canyon Rd. & Trilogy Pkwy.	Temescal Canyon Rd. & Dwy. 3	Temescal Canyon Rd. & Dwy. 4
142(285) 1(1) ← 156(215) 9(9) 2(4) 5(9)	146(293) 1(1) ← 165(224) 9(16)	124(312) 504(807) 135(280) 91(106) 150(127) 1334(639)	81(130) 8 515(783) 91(218) 65(91) 83(95) 1393(547)	10(11) 570(863) 1(3) 1476(642)	4(4) 568(861) 3(5) 1476(642)

**LEGEND:**

10(10) = AM(PM) PEAK HOUR INTERSECTION VOLUMES  
 10.0 = VEHICLES PER DAY (1000'S)





**EXHIBIT 6-2: EAPC (2023-FULL ACCESS AT DRIVEWAY 4) TRAFFIC VOLUMES**



1	2	3	4	5	6
Dwy. 1 & Trilogy Pkwy.	Dwy. 2 & Trilogy Pkwy.	Temescal Canyon Rd. & Lawson Rd.	Temescal Canyon Rd. & Trilogy Pkwy.	Temescal Canyon Rd. & Dwy. 3	Temescal Canyon Rd. & Dwy. 4
142(285) 1(1) 156(215) 5(5) 2(4) 3(5)	144(289) 1(1) 161(220) 7(13)	124(312) 504(807) 135(280) 91(106) 150(127) 1334(639)	81(130) 515(783) 86(210) 65(91) 80(91) 1398(555)	10(11) 570(863) 1(3) 1477(646)	4(4) 568(861) 5(8) 3(5) 4(4) 1473(638)

**LEGEND:**

10(10) = AM(PM) PEAK HOUR INTERSECTION VOLUMES

10.0 = VEHICLES PER DAY (1000'S)





EXHIBIT 6-3: EAPC (2023-RIRO AT DRIVEWAY 4) SUMMARY OF LOS

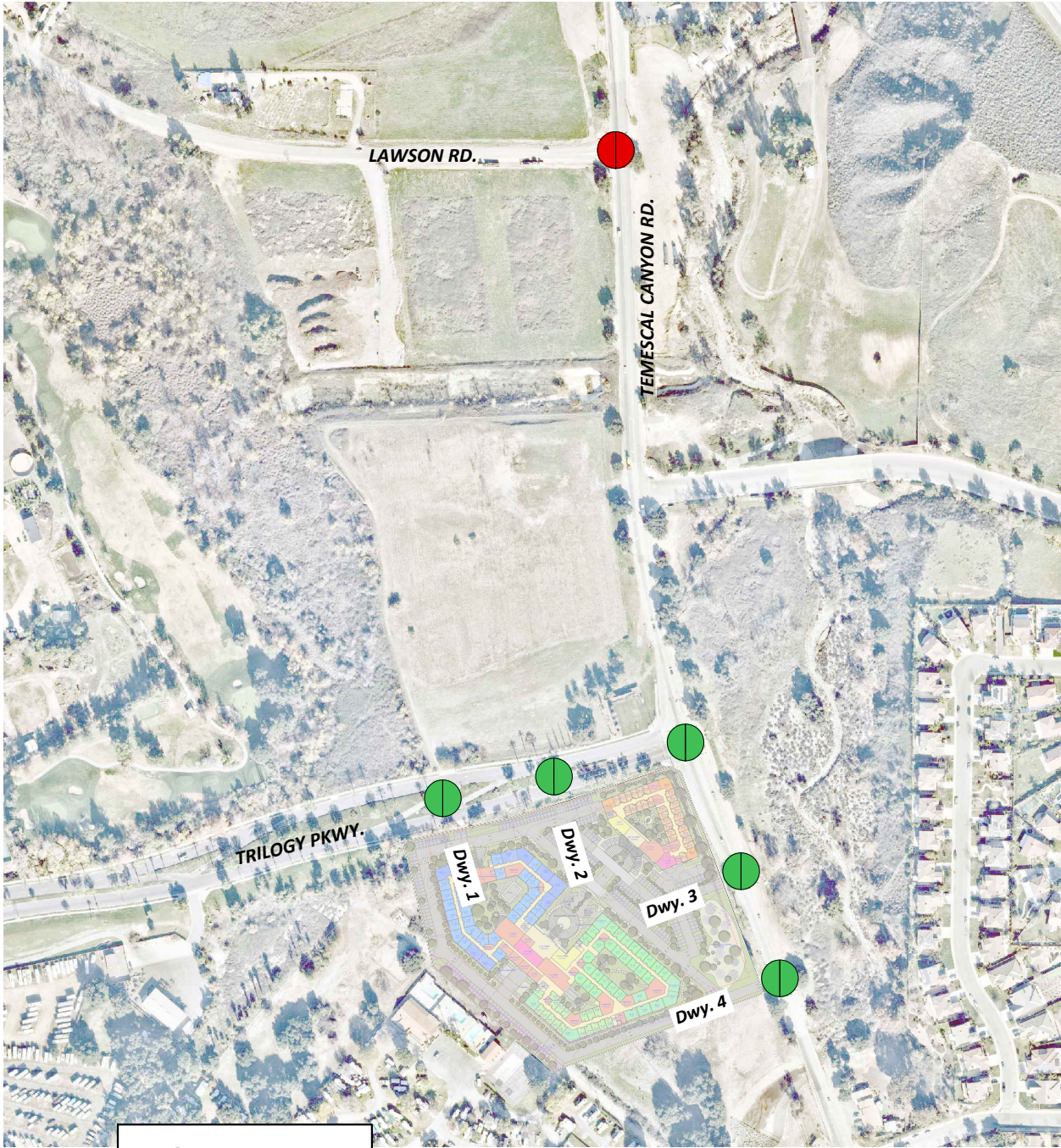

**LEGEND:**

- = AM PEAK HOUR
- = PM PEAK HOUR
- = LOS A-D
- = LOS E
- = LOS F





**EXHIBIT 6-4: EAPC (2023-FULL ACCESS AT DRIVEWAY 4) SUMMARY OF LOS**

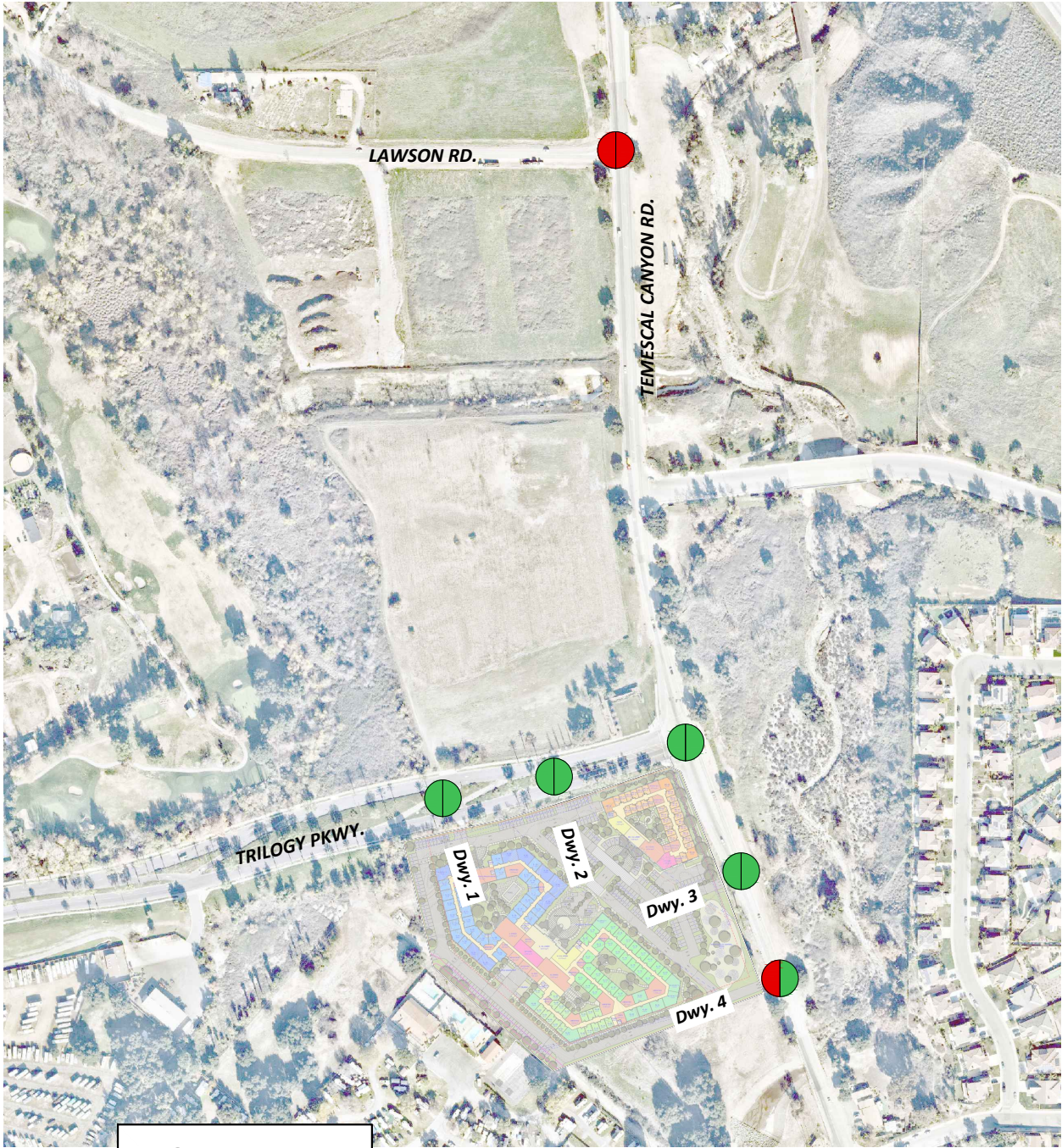

**LEGEND:**





-  = AM PEAK HOUR
-  = PM PEAK HOUR
-  = LOS A-D
-  = LOS E
-  = LOS F



Table 6-1

Intersection Analysis for EAPC (2023) Conditions

#	Intersection	Traffic Control <sup>2</sup>	EAPC (2023) - RIRO <sup>3</sup>				EAPC (2023) - FULL <sup>4</sup>			
			Delay <sup>1</sup> (secs.)		Level of Service		Delay <sup>1</sup> (secs.)		Level of Service	
			AM	PM	AM	PM	AM	PM	AM	PM
1	Driveway 1 & Trilogy Pkwy.	<u>CSS</u>	9.1	10.0	A	B	9.2	10.3	A	B
2	Driveway 2 & Trilogy Pkwy.	<u>CSS</u>	8.7	9.3	A	A	8.7	9.2	A	A
3	Temescal Canyon Rd. & Lawson Rd.	CSS	>100.0	>100.0	F	F	No Change			
4	Temescal Canyon Rd. & Trilogy Pkwy.	TS	26.8	13.4	C	B	27.2	13.2	C	B
5	Temescal Canyon Rd. & Driveway 3	<u>CSS</u>	12.4	16.3	B	C	12.4	16.3	B	C
6	Temescal Canyon Rd. & Driveway 4	<u>CSS</u>	12.4	16.3	B	C	<b>60.9</b>	31.9	<b>F</b>	D

\* **BOLD** = Level of Service (LOS) does not meet the applicable jurisdictional requirements (i.e., unacceptable LOS).

<sup>1</sup> Per the Highway Capacity Manual (6th Edition), overall average intersection delay and level of service are shown for intersections with a traffic signal or all way stop control. For intersections with cross street stop control, the delay and level of service for the worst individual movement (or movements sharing a single lane) are shown.

<sup>2</sup> CSS = Cross-street Stop; TS = Traffic Signal; CSS = Improvement

<sup>3</sup> LOS results assuming right-in/right-out access only at Driveway 4 on Temescal Canyon Road.

<sup>4</sup> LOS results assuming full access only at Driveway 4 on Temescal Canyon Road.

## 6.4 TRAFFIC SIGNAL WARRANTS ANALYSIS

Traffic signal warrants have been performed (based on CA MUTCD) for EAPC (2023) traffic conditions based on peak hour volumes for existing intersections and projected daily traffic volumes for future (driveway) intersections. There are no study area intersections anticipated to meet planning-level ADT traffic signal warrants under EAPC (2023) traffic conditions (see Appendix 6.3).

## 6.5 DEFICIENCIES AND RECOMMENDED IMPROVEMENTS

This section provides a summary of deficiencies and recommended improvements for EAPC (2023) traffic conditions. Based on the deficiency criteria discussed in Section 2.5 *Deficiency Criteria*, the following intersections were found to be deficient. Improvements necessary to improve traffic deficiencies back to acceptable levels are also discussed below. The effectiveness of the recommended improvement strategies to address EAPC (2023) traffic deficiencies are presented in Table 6-2. The intersection operations analysis worksheets for EAPC (2023) traffic conditions, with improvements, are included in Appendix 6.4.

The following improvements are necessary for EAPC (2023) traffic conditions with right-in/right-out access and full access at Driveway 4:

**Recommended Improvement – Temescal Canyon Road & Lawson Road (#3)** – The following improvements are necessary to bring the LOS back to acceptable levels:

- Install a traffic signal.
- Add a 2<sup>nd</sup> northbound through lane.
- Add a 2<sup>nd</sup> southbound through lane.

The following improvements are necessary for EAPC (2023) traffic conditions with full access at Driveway 4 only:

**Recommended Improvement – Temescal Canyon Road & Driveway 4 (#6)** – The following improvements are necessary to bring the LOS back to acceptable levels:

- Add a northbound left turn lane (Project improvement, needed for site access).
- Add a 2<sup>nd</sup> northbound through lane.
- Add a 2<sup>nd</sup> southbound through lane (Project frontage improvement).



Table 6-2

Intersection Analysis for EAPC (2023) Conditions With Improvements

#	Intersection	Traffic Control <sup>3</sup>	Intersection Approach Lanes <sup>1</sup>												Delay <sup>2</sup> (secs.)		Level of Service	
			Northbound			Southbound			Eastbound			Westbound			AM	PM	AM	PM
			L	T	R	L	T	R	L	T	R	L	T	R				
3	Temescal Canyon Rd. & Lawson Rd.																	
	- Without Improvements	CSS	1	1	0	0	1	0	0	1	0	0	0	0	>100.0	>100.0	F	F
	- With Improvements	TS	1	<u>2</u>	0	0	<u>2</u>	0	0	1	0	0	0	0	12.2	18.4	B	B
6	Temescal Canyon Rd. & Driveway 4																	
	- With Full Access at Driveway 4																	
	- Without Improvements	CSS	<u>1</u>	1	0	0	1	0	0	1	0	0	0	0	60.9	31.9	F	D
	- With Improvements	CSS	<u>1</u>	<u>2</u>	0	0	<u>2</u>	0	0	1	0	0	0	0	25.7	22.9	D	C

<sup>1</sup> When a right turn is designated, the lane can either be striped or unstriped. To function as a right turn lane there must be sufficient width for right turning vehicles to travel outside the through lanes.

L = Left; T = Through; R = Right; 1 = Improvement

<sup>2</sup> Per the Highway Capacity Manual (6th Edition), overall average intersection delay and level of service are shown for intersections with a traffic signal or all way stop control. For intersections with cross street stop control, the delay and level of service for the worst individual movement (or movements sharing a single lane) are shown.

<sup>3</sup> CSS = Cross-street Stop; TS = Traffic Signal; TS = Improvement

## 7 HORIZON YEAR (2040) TRAFFIC CONDITIONS

This section discusses the methods used to develop Horizon Year (2040) Without and With Project traffic forecasts, and the resulting intersection operations and traffic signal warrant analyses.

### 7.1 ROADWAY IMPROVEMENTS

The lane configurations and traffic controls assumed to be in place for Horizon Year (2040) conditions are consistent with those shown previously on Exhibit 3-1, with the exception of the following:

- Project driveways and those facilities assumed to be constructed by the Project to provide site access are also assumed to be in place for Horizon Year (2040) conditions only (e.g., intersection and roadway improvements along the Project's frontage and driveways).
- Driveways and those facilities assumed to be constructed by cumulative developments to provide site access are also assumed to be in place for Horizon Year (2040) conditions only (e.g., intersection and roadway improvements along the cumulative development's frontages).

### 7.2 HORIZON YEAR (2040) WITHOUT PROJECT TRAFFIC VOLUME FORECASTS

This scenario includes the refined post-processed volumes obtained from the RivTAM consistent with the currently adopted General Plan Circulation Element (see Section 4.8 *Horizon Year (2040) Volume Development* of this TA for a detailed discussion on the post-processing methodology). The Horizon Year (2040) Without Project traffic forecasts reflect the future roadway network contemplated by the County's General Plan, which includes the future Temescal Canyon Road extension. The weekday ADT and weekday AM and PM peak hour volumes which can be expected for Horizon Year (2040) Without Project traffic conditions are shown on Exhibit 7-1.

### 7.3 HORIZON YEAR (2040) WITH PROJECT TRAFFIC VOLUME FORECASTS

This scenario includes the refined post-processed volumes obtained from the RivTAM consistent with the currently adopted General Plan Circulation Element, plus proposed Project volumes. The weekday ADT and weekday AM and PM peak hour volumes which can be expected for Horizon Year (2040) With Project traffic conditions are shown on Exhibits 7-2 and 7-3, respectively, with right-in/right-out and full access at Driveway 4.

**EXHIBIT 7-1: HORIZON YEAR (2040) WITHOUT PROJECT TRAFFIC VOLUMES**



1	2	3	4	5	6
Dwy. 1 & Trilogy Pkwy.	Dwy. 2 & Trilogy Pkwy.	Temescal Canyon Rd. & Lawson Rd.	Temescal Canyon Rd. & Trilogy Pkwy.	Temescal Canyon Rd. & Dwy. 3	Temescal Canyon Rd. & Dwy. 4
Future Intersection	Future Intersection			Future Intersection	Future Intersection

**LEGEND:**

10(10) = AM(PM) PEAK HOUR INTERSECTION VOLUMES  
 10.0 = VEHICLES PER DAY (1000'S)





**EXHIBIT 7-2: HORIZON YEAR (2040) WITH PROJECT (2040-RIRO AT DRIVEWAY 4) TRAFFIC VOLUMES**



1	2	3	4	5	6
Dwy. 1 & Trilogy Pkwy.	Dwy. 2 & Trilogy Pkwy.	Temescal Canyon Rd. & Lawson Rd.	Temescal Canyon Rd. & Trilogy Pkwy.	Temescal Canyon Rd. & Dwy. 3	Temescal Canyon Rd. & Dwy. 4
161(347) 1(1) 184(255) 9(9) 2(4) 5(9)	165(355) 1(1) 193(264) 9(16)	136(338) 618(996) 154(293) 94(113) 183(136) 1690(784)	97(157) 616(951) 103(267) 72(104) 95(108) 1771(653)	10(11) 693(1062) 1(3) 1866(761)	4(4) 691(1060) 3(5) 1866(761)

**LEGEND:**

10(10) = AM(PM) PEAK HOUR INTERSECTION VOLUMES  
 10.0 = VEHICLES PER DAY (1000'S)





**EXHIBIT 7-3: HORIZON YEAR (2040) WITH PROJECT (2040-FULL ACCESS AT DRIVEWAY 4)  
TRAFFIC VOLUMES**



1	2	3	4	5	6
Dwy. 1 & Trilogy Pkwy.	Dwy. 2 & Trilogy Pkwy.	Temescal Canyon Rd. & Lawson Rd.	Temescal Canyon Rd. & Trilogy Pkwy.	Temescal Canyon Rd. & Dwy. 3	Temescal Canyon Rd. & Dwy. 4
161(347) 1(1) ← 184(255) 5(5)	163(351) 1(1) ← 189(260)	136(338) 618(996) 154(293) 94(113) 183(136) 1690(784)	97(157) 616(951) 98(259) 72(104) 92(104) 1776(661)	10(11) 693(1062) 1(3)	4(4) 691(1060) 5(8) 3(5) 4(4) 1863(757)

**LEGEND:**

10(10) = AM(PM) PEAK HOUR INTERSECTION VOLUMES  
 10.0 = VEHICLES PER DAY (1000'S)



## 7.4 INTERSECTION OPERATIONS ANALYSIS

### 7.4.1 HORIZON YEAR (2040) WITHOUT PROJECT TRAFFIC CONDITIONS

Level of service calculations were conducted for the study intersections to evaluate their operations under Horizon Year (2040) Without Project traffic conditions with existing roadway and intersection geometrics consistent with those described under Section 1.6 *Recommendations*. As shown in Table 7-1 and illustrated on Exhibit 7-4, the following study area intersections are anticipated to operate at an unacceptable LOS under Horizon Year (2040) Without Project traffic conditions:

- Temescal Canyon Road & Lawson Road (#3) – LOS F AM and PM peak hours
- Temescal Canyon Road & Trilogy Parkway (#4) – LOS F AM peak hour

The intersection operations analysis worksheets for Horizon Year (2040) Without Project traffic conditions are included in Appendix 7.1 of this report.

### 7.4.2 HORIZON YEAR (2040) WITH PROJECT TRAFFIC CONDITIONS

As shown in Table 7-1 and illustrated on Exhibit 7-5 (right-in/right-out at Driveway 4), with the addition of Project traffic, there are no additional intersections anticipated to result in an unacceptable LOS with right-in/right-out access at Driveway 4, in addition to the intersections previously identified under Horizon Year (2040) Without Project traffic conditions. The intersection operations analysis worksheets for Horizon Year (2040) With Project (right-in/right-out access at Driveway 4) traffic conditions are included in Appendix 7.2 of this report.

As shown in Table 7-1 and illustrated on Exhibit 7-6 (full access at Driveway 4), with the addition of Project traffic, the following additional study area intersection is anticipated to operate at an unacceptable LOS with full access at Driveway 4, in addition to the intersections previously identified under Horizon Year (2040) Without Project traffic conditions:

- Temescal Canyon Road & Driveway 4 (#6) – LOS F AM and PM peak hours

The intersection operations analysis worksheets for Horizon Year (2040) With Project (full access at Driveway 4) traffic conditions are included in Appendix 7.3 of this report.

## 7.5 TRAFFIC SIGNAL WARRANTS ANALYSIS

The only existing study area intersection is anticipated to meet a traffic signal warrant under EAPC (2023) traffic conditions. Since there are no other unsignalized study area intersections under Horizon Year (2040) Without Project traffic conditions, no traffic signal warrant analysis has been performed for this analysis scenario.

Traffic signal warrants have been performed (based on CA MUTCD) for Horizon Year (2040) With Project traffic conditions based on daily traffic volumes for the future (driveway) intersections. For Horizon Year (2040) With Project traffic conditions, no additional study area intersections are anticipated to meet planning-level ADT traffic signal warrants in addition to the intersections previously warranted under EAPC (2023) traffic conditions (see Appendix 7.4).



Table 7-1

Intersection Analysis for Horizon Year (2040) Conditions

#	Intersection	Traffic Control <sup>2</sup>	2040 Without Project				2040 With Project - RIRO <sup>3</sup>				2040 With Project - FULL <sup>4</sup>			
			Delay <sup>1</sup> (secs.)		Level of Service		Delay <sup>1</sup> (secs.)		Level of Service		Delay <sup>1</sup> (secs.)		Level of Service	
			AM	PM	AM	PM	AM	PM	AM	PM	AM	PM	AM	PM
1	Driveway 1 & Trilogy Pkwy.	<u>CSS</u>	Does Not Exist		9.3	10.5	A	B	9.4	10.9	A	B		
2	Driveway 2 & Trilogy Pkwy.	<u>CSS</u>	Does Not Exist		8.8	9.5	A	A	8.8	9.5	A	A		
3	Temescal Canyon Rd. & Lawson Rd.	CSS	>100.0	>100.0	F	F	F	F	No Change	No Change	F	C		
4	Temescal Canyon Rd. & Trilogy Pkwy.	TS	103.5	20.9	F	C	F	C	104.2	23.3	F	C		
5	Temescal Canyon Rd. & Driveway 3	<u>CSS</u>	Does Not Exist		13.9	20.5	B	C	13.9	20.5	B	C		
6	Temescal Canyon Rd. & Driveway 4	<u>CSS</u>	Does Not Exist		13.9	20.6	B	C	>100.0	52.3	F	F		

<sup>1</sup> Per the Highway Capacity Manual (6th Edition), overall average intersection delay and level of service are shown for intersections with a traffic signal or all-way stop control. For intersections with cross street-stop control, the delay and level of service for the worst individual movement (or movements sharing a single lane) are shown.

<sup>2</sup> CSS = Cross-street Stop; TS = Traffic Signal; CSS = Improvement

<sup>3</sup> LOS results assuming right-in/right-out access only at Driveway 4 on Temescal Canyon Road.

<sup>4</sup> LOS results assuming full access only at Driveway 4 on Temescal Canyon Road.

**EXHIBIT 7-4: HORIZON YEAR (2040) WITHOUT PROJECT SUMMARY OF LOS**

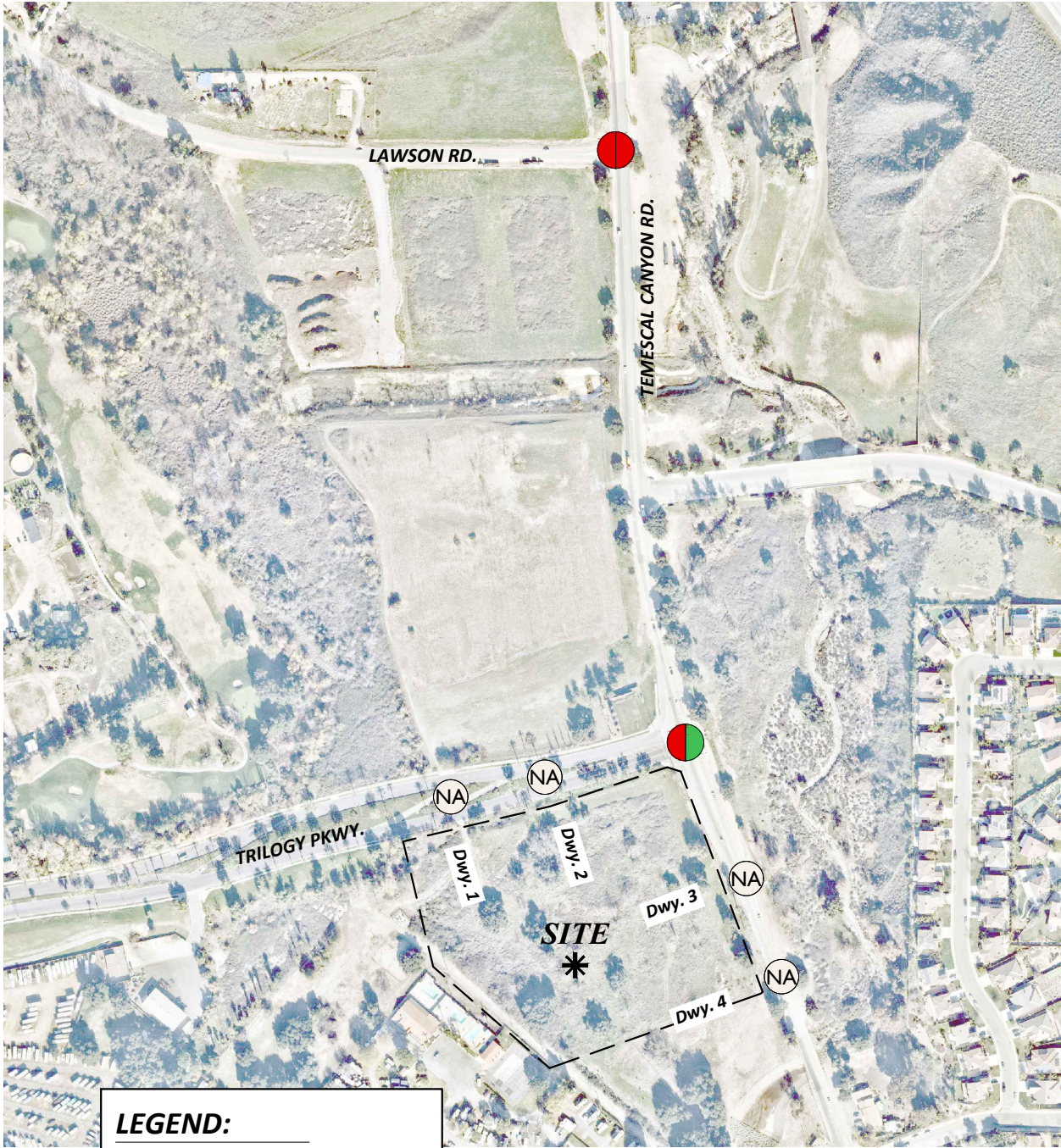

**LEGEND:**

- = AM PEAK HOUR
- = PM PEAK HOUR
- = LOS A-D
- = LOS E
- = LOS F
- = NOT AN ANALYSIS LOCATION FOR THIS SCENARIO







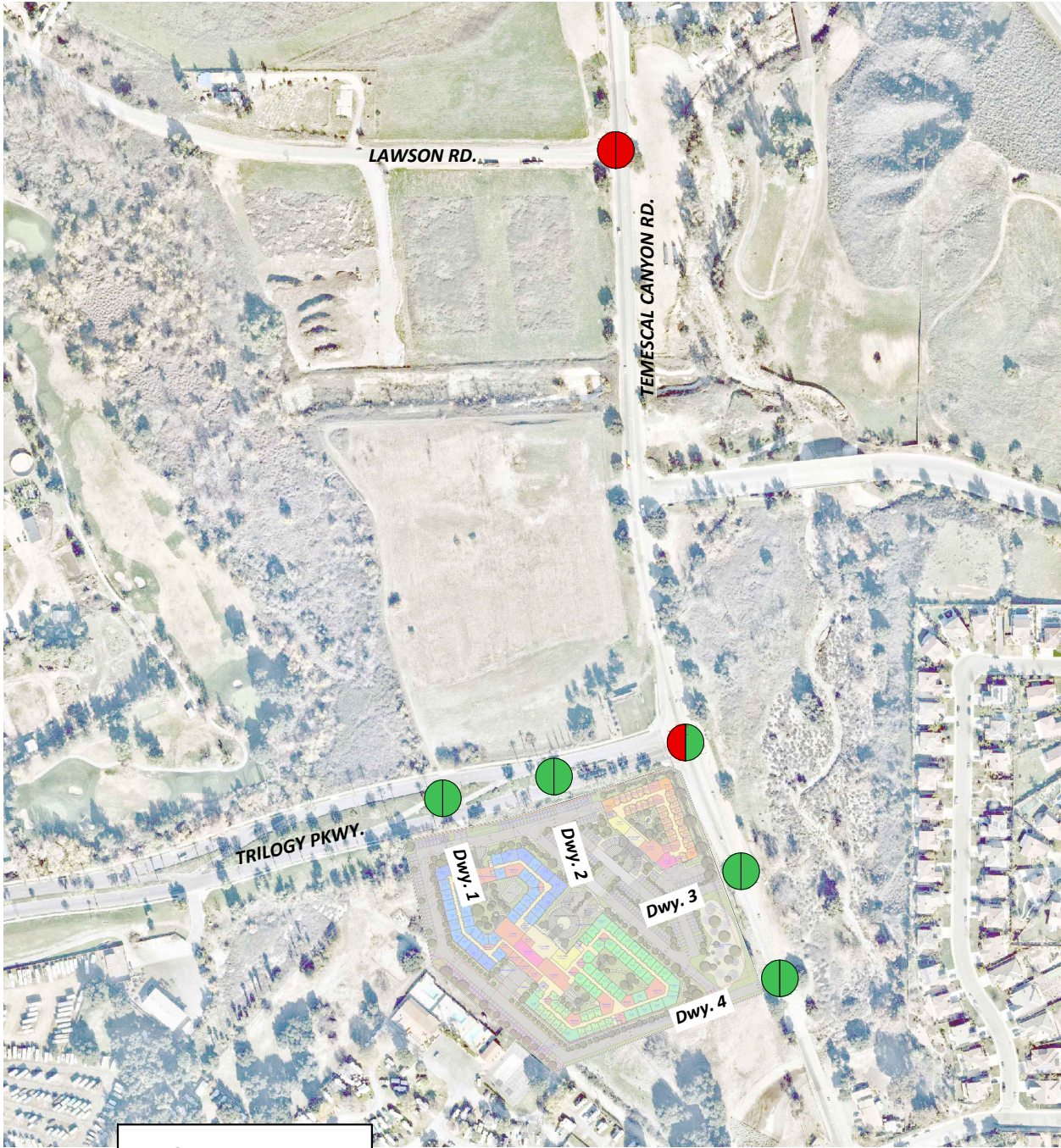

**EXHIBIT 7-5: HORIZON YEAR (2040) WITH PROJECT (2040-RIRO AT DRIVEWAY 4) SUMMARY OF LOS**



**LEGEND:**

-  = AM PEAK HOUR
-  = PM PEAK HOUR
-  = LOS A-D
-  = LOS E
-  = LOS F







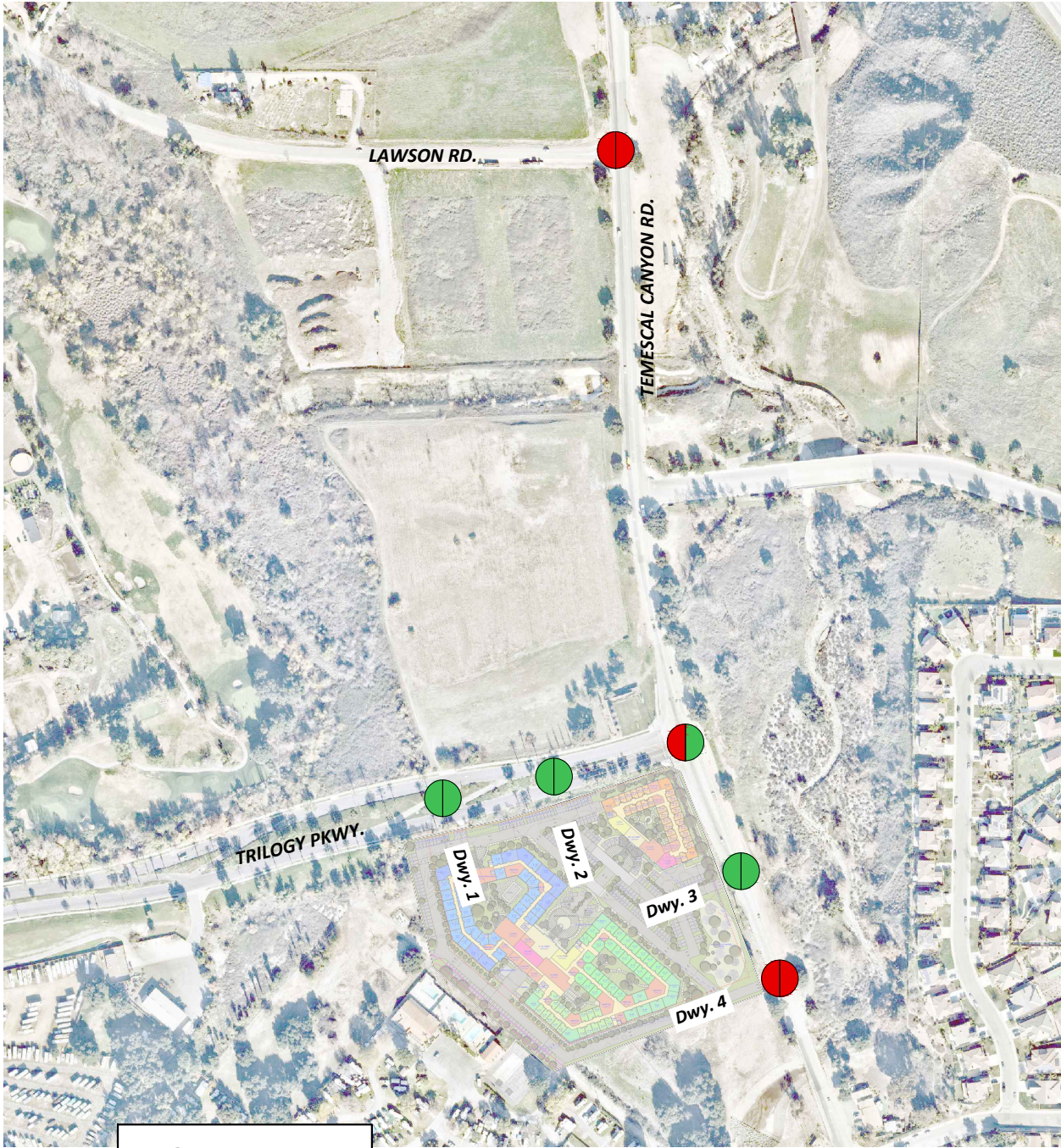

**EXHIBIT 7-6: HORIZON YEAR (2040) WITH PROJECT (2040-FULL ACCESS AT DRIVEWAY 4)  
SUMMARY OF LOS**



**LEGEND:**

-  = AM PEAK HOUR
-  = PM PEAK HOUR
-  = LOS A-D
-  = LOS E
-  = LOS F



## 7.6 DEFICIENCIES AND RECOMMENDED IMPROVEMENTS

This section provides a summary of deficiencies and recommended improvements for Horizon Year (2040) traffic conditions. Based on the deficiency criteria discussed in Section 2.5 *Deficiency Criteria*, the following intersections were found to be deficient. Improvements necessary to improve traffic deficiencies back to acceptable levels are also discussed below. The effectiveness of the recommended improvement strategies discussed below to address Horizon Year (2040) traffic deficiencies are presented in Table 7-2. The intersection operations analysis worksheets for Horizon Year (2040) With Project traffic conditions, with improvements, are included in Appendix 7.5.

The following improvements are necessary for Horizon Year (2040) With Project traffic conditions with right-in/right-out access and full access at Driveway 4:

**Recommended Improvement – Temescal Canyon Road & Lawson Road (#3)** – The following improvements are necessary to bring the LOS back to acceptable levels:

- Install a traffic signal.
- Add a 2<sup>nd</sup> northbound through lane.
- Add a 2<sup>nd</sup> southbound through lane.

**Recommended Improvement – Temescal Canyon Road & Trilogy Parkway (#4)** – The following improvements are necessary to bring the LOS back to acceptable levels:

- Add a 2<sup>nd</sup> northbound through lane.
- Add a 2<sup>nd</sup> southbound through lane.

The following improvements are necessary for Horizon Year (2040) With Project traffic conditions with full access at Driveway 4 only:

**Recommended Improvement – Temescal Canyon Road & Driveway 4 (#6)** – The following improvements are necessary to bring the LOS back to acceptable levels:

- Add a northbound left turn lane (Project improvement, needed for site access).
- Add a 2<sup>nd</sup> northbound through lane.
- Add a 2<sup>nd</sup> southbound through lane (Project frontage improvement).



Table 7-2

Intersection Analysis for EAPC (2022) Conditions With Improvements

#	Intersection	Traffic Control <sup>3</sup>	Intersection Approach Lanes <sup>1</sup>												Delay <sup>2</sup> (secs.)		Level of Service	
			Northbound			Southbound			Eastbound			Westbound			AM	PM	AM	PM
			L	T	R	L	T	R	L	T	R	L	T	R				
3	Temescal Canyon Rd. & Lawson Rd.																	
	- Without Improvements	CSS	1	1	0	0	1	0	0	1	0	0	0	0	>100.0	>100.0	F	F
	- With Improvements	TS	1	<u>2</u>	0	0	<u>2</u>	0	0	1	0	0	0	0	16.9	26.4	B	C
4	Temescal Canyon Rd. & Trilogy Pkwy.																	
	- With RIRO Access at Driveway 4																	
	- Without Improvements	TS	1	1	0	0	1	1	1	0	1	0	0	0	103.1	24.5	F	C
	- With Improvements	TS	1	<u>2</u>	0	0	<u>2</u>	1	1	0	1	0	0	0	8.7	11.2	A	B
	- With Full Access at Driveway 4																	
	- Without Improvements	TS	1	1	0	0	1	1	1	0	1	0	0	0	104.2	23.3	F	C
	- With Improvements	TS	1	<u>2</u>	0	0	<u>2</u>	1	1	0	1	0	0	0	8.6	11.0	A	B
6	Temescal Canyon Rd. & Driveway 4																	
	- With Full Access at Driveway 4																	
	- Without Improvements	CSS	<u>1</u>	1	0	0	1	0	0	1	0	0	0	0	>100.0	52.3	F	F
	- With Improvements	CSS	<u>1</u>	<u>2</u>	0	0	<u>2</u>	0	0	1	0	0	0	0	19.3	19.8	C	C

<sup>1</sup> When a right turn is designated, the lane can either be striped or unstriped. To function as a right turn lane there must be sufficient width for right turning vehicles to travel outside the through lanes.

L = Left; T = Through; R = Right; > = Right-Turn Overlap Phasing; >> = Free-Right Turn Lane; 1 = Improvement

<sup>2</sup> Per the Highway Capacity Manual (6th Edition), overall average intersection delay and level of service are shown for intersections with a traffic signal or all way stop control. For intersections with cross street stop control, the delay and level of service for the worst individual movement (or movements sharing a single lane) are shown.

<sup>3</sup> TS = Traffic Signal; TS = Improvement

This Page Intentionally Left Blank



## 8 LOCAL AND REGIONAL FUNDING MECHANISMS

Transportation improvements within the County of Riverside are funded through a combination of improvements constructed by the Project, development impact fee programs or fair share contributions. Fee programs applicable to the Project are described below.

### 8.1 RIVERSIDE COUNTY TRANSPORTATION UNIFORM MITIGATION FEE (TUMF)

The TUMF program is administered by the WRCOG based upon a regional Nexus Study most recently updated in 2016 to address major changes in right of way acquisition and improvement cost factors. (10) This regional program was put into place to ensure that development pays its fair share and that funding is in place for construction of facilities needed to maintain the requisite level of service and critical to mobility in the region. TUMF is a truly regional mitigation fee program and is imposed and implemented in every jurisdiction in Western Riverside County.

### 8.2 COUNTY OF RIVERSIDE DEVELOPMENT IMPACT FEE (DIF) PROGRAM

The Project is located within the County's Temescal Canyon Area Plan and therefore will be subject to County of Riverside DIF in an effort by the County to address development throughout its unincorporated area. The DIF program consists of two separate transportation components: the Roads, Bridges and Major Improvements component and the Traffic Signals component. Eligible facilities for funding by the County DIF program are identified on the County's Public Needs List, which currently extends through the year 2020. (11) A comprehensive review of the DIF program is now planned in order to update the nexus study. This will result in development of a revised "needs list" extending the program time horizon from 2010 to 2030.

The cost of signaling DIF network intersections is identified under the Traffic Signals component of the DIF program. County staff generally defines DIF eligible intersections as those consisting of two intersecting general plan roadways. If the intersection meets this requirement, it is potentially eligible for up to \$235,000 of credit, which is subject to negotiations with the County.

### 8.3 MEASURE A

Measure A, Riverside County's half-cent sales tax for transportation, was adopted by voters in 1988 and extended in 2002. It will continue to fund transportation improvements through 2039. Measure A funds a wide variety of transportation projects and services throughout the County. RCTC is responsible for administering the program. Measure A dollars are spent in accordance with a voter-approved expenditure plan that was adopted as part of the 1988 election.

This Page Intentionally Left Blank

## 9 REFERENCES

1. **Riverside County Transportation Department.** *Traffic Impact Analysis Preparation Guide.* County of Riverside : s.n., April 2008.
2. **California Department of Transportation.** *Guide for the Preparation of Traffic Impact Studies.* December 2002.
3. **Institute of Transportation Engineers (ITE).** *Trip Generation Manual.* 10th Edition. 2017.
4. **Western Riverside Council of Governments.** *TUMF Nexus Study, 2016 Program Update.* July 2017.
5. **Riverside County Transportation Commission.** *2011 Riverside County Congestion Management Program.* County of Riverside : RCTC, December 14, 2011.
6. **Transportation Research Board.** *Highway Capacity Manual (HCM).* 6th Edition. s.l. : National Academy of Sciences, 2016.
7. **California Department of Transportation.** California Manual on Uniform Traffic Control Devices (MUTCD). [book auth.] California Department of Transportation. *California Manual on Uniform Traffic Control Devices (CAMUTCD).* 2017.
8. **Southern California Association of Governments.** *2020 Regional Transportation Plan / Sustainable Communities Strategy.* May 2020 (to be adopted September 2020).
9. **Western Riverside Council of Governments.** *TUMF Nexus Study, 2016 Program Update.* July 2017.
10. **Willdan Financial Services.** *County of Riverside Development Impact Fee Study Update.* County of Riverside : s.n., 2013.



This Page Intentionally Left Blank

**APPENDIX 1.1:**

**APPROVED TRAFFIC STUDY SCOPING AGREEMENT**

This Page Intentionally Left Blank



**EXHIBIT B**

**SCOPING AGREEMENT FOR TRAFFIC IMPACT STUDY**

This letter acknowledges the Riverside County Transportation Department requirements for traffic impact analysis of the following project. The analysis must follow the Riverside County Transportation Department Traffic Study Guidelines dated April 2008.

Case No. \_\_\_\_\_  
 Related Cases- \_\_\_\_\_  
     SP No. \_\_\_\_\_  
     EIR No. \_\_\_\_\_  
     GPA No. \_\_\_\_\_  
     CZ No. \_\_\_\_\_  
 Project Name: Glen Ivy Senior Community  
 Project Address: Southwest corner of Temescal Canyon Road and Trilogy Parkway  
 Project Description: 144 assisted living dwelling units (112 standard assisted living dwelling units and 32 memory care dwelling units) and 76 senior adult housing attached dwelling units

	<u>Consultant</u>	<u>Developer</u>
Name:	<u>Urban Crossroads Inc. - Charlene So</u>	<u>Glen Ivy Properties, LLC</u>
Address:	<u>260 E. Baker Street, Suite 200</u> <u>Costa Mesa, CA 92626</u>	<u>34145 Pacific Coast Highway #621</u> <u>Dana Point, CA 92629</u>
Telephone:	<u>(949) 336-5982</u>	_____
Fax:	_____	_____

**A. Trip Generation Source:** ITE Trip Generation Manual, 10th Edition (2017)

Current GP Land Use	<u>Commercial Retail</u>	Proposed Land Use	<u>Residential</u>
Current Zoning	<u>Commercial Retail</u>	Proposed Zoning	<u>Residential (R-2)</u>

	Current Trip Generation			Proposed Trip Generation		
	<u>In</u>	<u>Out</u>	<u>Total</u>	<u>In</u>	<u>Out</u>	<u>Total</u>
AM Trips	_____	_____	_____	<u>22</u>	<u>20</u>	<u>42</u>
PM Trips	_____	_____	_____	<u>25</u>	<u>32</u>	<u>57</u>

Internal Trip Allowance       Yes     No      ( 0 % Trip Discount)  
 Pass-By Trip Allowance       Yes     No      ( 0 % Trip Discount)

A passby trip discount of 25% is allowed for appropriate land uses. The passby trips at adjacent study area intersections and project driveways shall be indicated on a report figure.

**B. Trip Geographic Distribution:** (See attached Exhibit 3 for detailed assignment)  
 N varies %      S varies %      E varies %      W varies %

**C. Background Traffic**  
 Project Build-out Year: 2023      Annual Ambient Growth Rate: 2 %  
 Phase Year(s) N/A

Other area Projects to be analyzed: To be provided by County Staff  
 Model/Forecast Methodology: RivTAM



**D. Study Intersections:** (NOTE: Subject to revision after other projects, trip generation and distribution are determined, or comments form other agencies). (See Exhibit 2)

- |  |           |
|--|-----------|
| 1. <u>Driveway 1 &amp; Trilogy Pkwy.</u>                             | 11. _____ |
| 2. <u>Driveway 2 &amp; Trilogy Pkwy. - Future Intersection</u>       | 12. _____ |
| 3. <u>Temescal Canyon Rd. &amp; Trilogy Pkwy.</u>                    | 13. _____ |
| 4. <u>Temescal Canyon Rd. &amp; Driveway 3 - Future Intersection</u> | 14. _____ |
| 5. <u>Temescal Canyon Rd. &amp; Driveway 4 - Future Intersection</u> | 15. _____ |
| 6. <u>Temescal Canyon Rd. &amp; Lawson Road</u>                      | 16. _____ |
| 7. _____   | 17. _____ |
| 8. _____   | 18. _____ |
| 9. _____   | 19. _____ |
| 10. _____  | 20. _____ |

**E. Study Roadway Segments:** (NOTE: Subject to revision after other projects, trip generation and distribution are determined, or comments form other agencies).

1. \_\_\_\_\_ 2. \_\_\_\_\_

**F. Other Jurisdictional Impacts**

Is this project within a City's Sphere of influence or one mile radius of City boundaries?

Yes  No

If so, name of City jurisdiction: ~~N/A~~ Corona

**G. Site Plan** (please attach reduced copy)

**H. Specific issues to be addressed in the Study (in addition to the standard analysis described in the Guideline)** (To be filled out by Transportation Department)

(NOTE: If the traffic study states that "a traffic signal is warranted" (or "a traffic signal appears to be warranted", or similar statement) at an existing unsignalized intersection under existing conditions, 8-hour approach traffic volume information must be submitted in addition to the peak hourly turning movement counts for that intersection.

LOS analysis and VMT analysis will be required.

**I. Existing Conditions**

Traffic count data must be new or recent. Provide traffic count dates if using other than new counts.

Date of counts: 11/13/2019 counts will be utilized in conjunction with a 2 percent growth rate

**\*NOTE\* Traffic Study Submittal Form and appropriate fee must be submitted with, or prior to submittal of this form. Transportation Department staff will not process the Scoping Agreement prior to receipt of the fee.**

**Recommended by:**

*Charlene S*

6/12/2020

Consultant's Representative

Date

**Approved Scoping Agreement:**

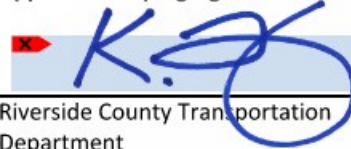

08/17/2020

Riverside County Transportation Department

Date

June 12, 2020

Mr. Kevin Tsang  
County of Riverside, Transportation Department  
4080 Lemon Street, 8th Floor  
Riverside, CA 92501

**SUBJECT: GLEN IVY SENIOR COMMUNITY TRAFFIC IMPACT ANALYSIS SCOPING AGREEMENT**

Dear Mr. Kevin Tsang:

The firm of Urban Crossroads, Inc. is pleased to submit this scoping letter regarding the traffic impact analysis for Glen Ivy Senior Community development (“Project”), which is located on the southwest corner of Temescal Canyon Road and Trilogy Parkway in the County of Riverside. This letter describes the proposed Project trip generation, trip distribution, and analysis methodology, which have been used to establish the draft proposed Project study area and analysis locations.

## **PROJECT DESCRIPTION**

A preliminary site use plan for the proposed Project is shown on Exhibit 1. Exhibit 2 depicts the location of the proposed project in relation to the existing roadway network. The Project is anticipated to have an Opening Year of 2023. Access to the Project site will be provided to Temescal Canyon Road and Trilogy Parkway. The proposed Project consists of 144 assisted living dwelling units (112 standard assisted living dwelling units and 32 memory care dwelling units) and 76 senior adult housing attached dwelling units.

## **TRIP GENERATION**

Trip generation represents the amount of traffic that is attracted and produced by a development and is based upon the specific land uses planned for a given project. In order to develop the traffic characteristics of the proposed project, trip-generation statistics published in the Institute of Transportation Engineers (ITE) [Trip Generation Manual](#) (10<sup>th</sup> Edition, 2017). The trip generation rates and summary for the proposed Project are shown in Table 1. As shown in Table 1, the proposed Project is anticipated to generate a total of 658 vehicle trip-ends per day with 43 AM peak hour trips and 57 PM peak hour trips.

## **TRIP DISTRIBUTION**

The Project trip distribution represents the directional orientation of traffic to and from the Project site. Trip distribution is the process of identifying the probable destinations, directions or traffic routes that will be utilized by Project traffic. The potential interaction between the planned land uses and surrounding regional access routes are considered, to identify the route where the Project traffic would



distribute. Exhibit 3 illustrates the anticipated trip distribution patterns for the Project.

## **ANALYSIS SCENARIOS**

Consistent with the County's TIA guidelines, intersection analysis will be provided for the following analysis scenarios:

- Existing (2020) Conditions
- Existing plus Ambient Growth plus Project (EAP) Conditions
- Existing plus Ambient Growth plus Project plus Cumulative (EAPC) Conditions
- Horizon Year (2040) Without Project Conditions
- Horizon Year (2040) With Project Conditions

All study area intersections will be evaluated using the Highway Capacity Manual (HCM) 6<sup>th</sup> Edition analysis methodology.

## **SPECIAL ISSUES**

The following special issue will also be addressed as part of the TIA:

- Site Access Evaluation: The turn pocket lengths will be determined through peak hour traffic simulations developed using Synchro and SimTraffic software in an effort to identify the required storage capacity for turn lanes at the Project driveways.

## **CUMULATIVE PROJECTS**

A preliminary list of cumulative projects is provided in Table 2 and are shown on Exhibit 4. It is requested that County staff provide an updated list of cumulative projects for inclusion in the traffic study.

## **TRAFFIC COUNTS**

In light of current economic conditions and social-distancing practices in place, historical traffic counts will be utilized from 2019. A 2 percent growth factor will be applied to these traffic counts to reflect 2020 baseline conditions. The 2019 traffic counts were collected on Wednesday November 13, 2019, when local schools were in session and operating on a typical bell schedule.

Mr. Kevin Tsang  
County of Riverside, Transportation Department  
June 12, 2020  
Page 3 of 3

## CONCLUSION

Urban Crossroads, Inc. is pleased to submit this letter documenting the Project trip generation, trip distribution, and the recommended intersection analysis locations for the Glen Ivy Senior Community Traffic Impact Study. We will continue to move forward towards completing the traffic study after receiving jurisdiction approval or comments finalizing the study area.

If you have any questions, please contact me directly at (949) 336-5982.

Respectfully submitted,

URBAN CROSSROADS, INC.



Charlene So, PE  
Associate Principal

EXHIBIT 1: PRELIMINARY SITE PLAN

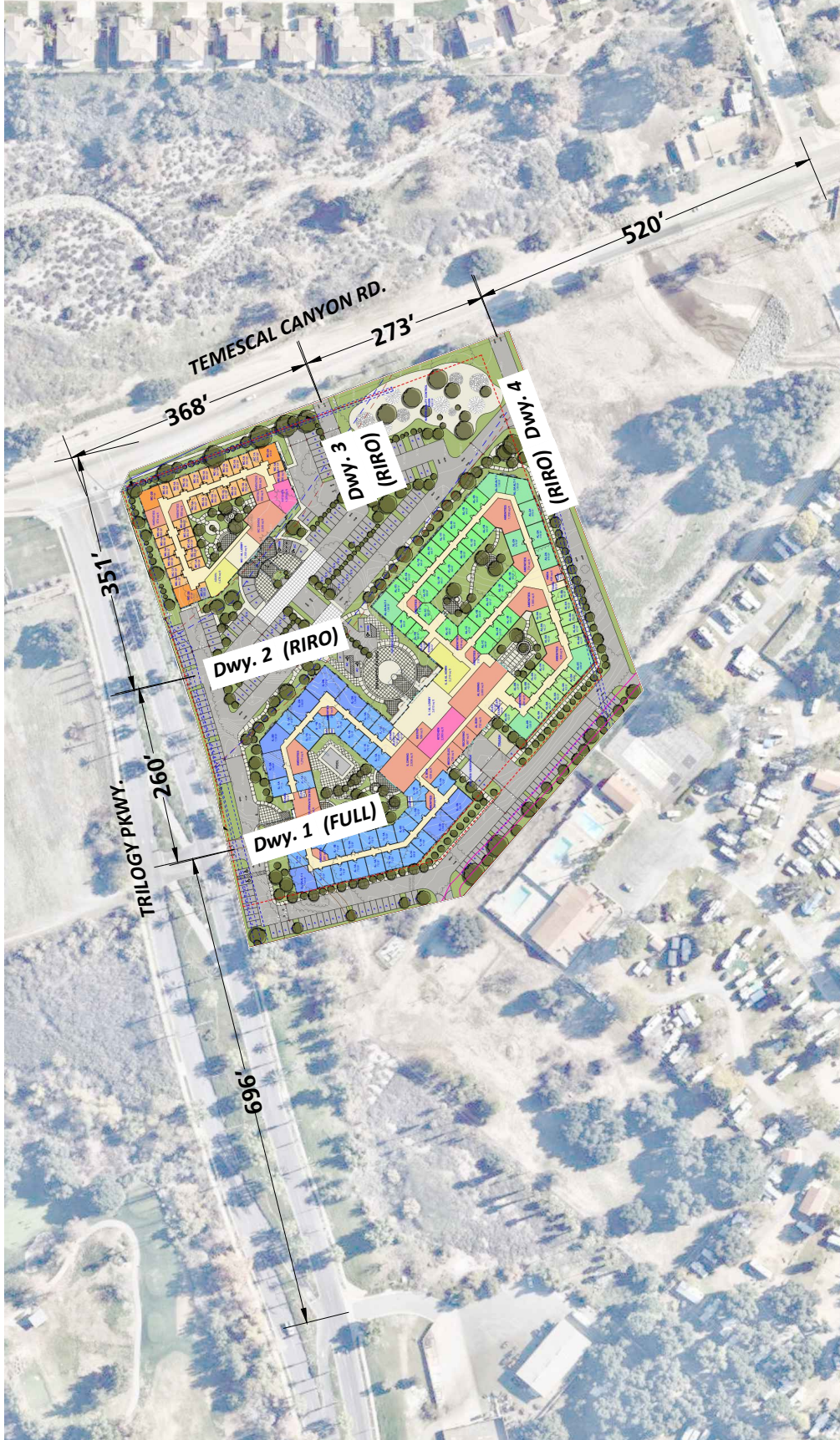

**LEGEND:**

RIRO = RIGHT-IN/RIGHT-OUT ONLY ACCESS

FULL = FULL ACCESS





EXHIBIT 2: LOCATION MAP



**LEGEND:**

- ①** = EXISTING INTERSECTION ANALYSIS LOCATION
- ②** = FUTURE INTERSECTION ANALYSIS LOCATION
- RIRO** = RIGHT-IN/RIGHT-OUT ONLY ACCESS
- FULL** = FULL ACCESS





**EXHIBIT 3: PROJECT TRIP DISTRIBUTION**

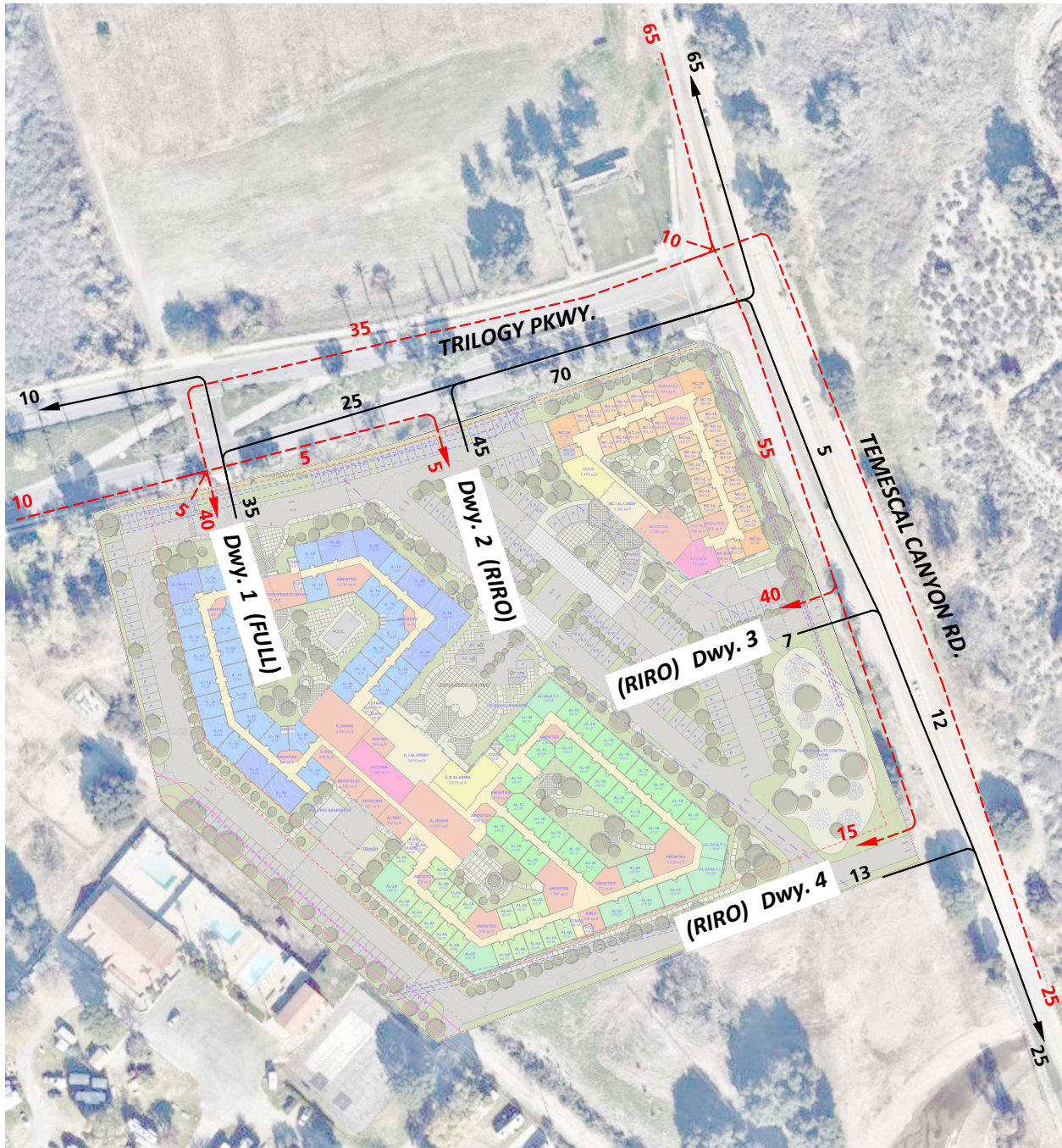

**LEGEND:**

- 10 = PERCENT TO/FROM PROJECT
- ← = OUTBOUND
- ← (red dashed) = INBOUND





**EXHIBIT 4: CUMULATIVE DEVELOPMENT PROJECTS LOCATION MAP**

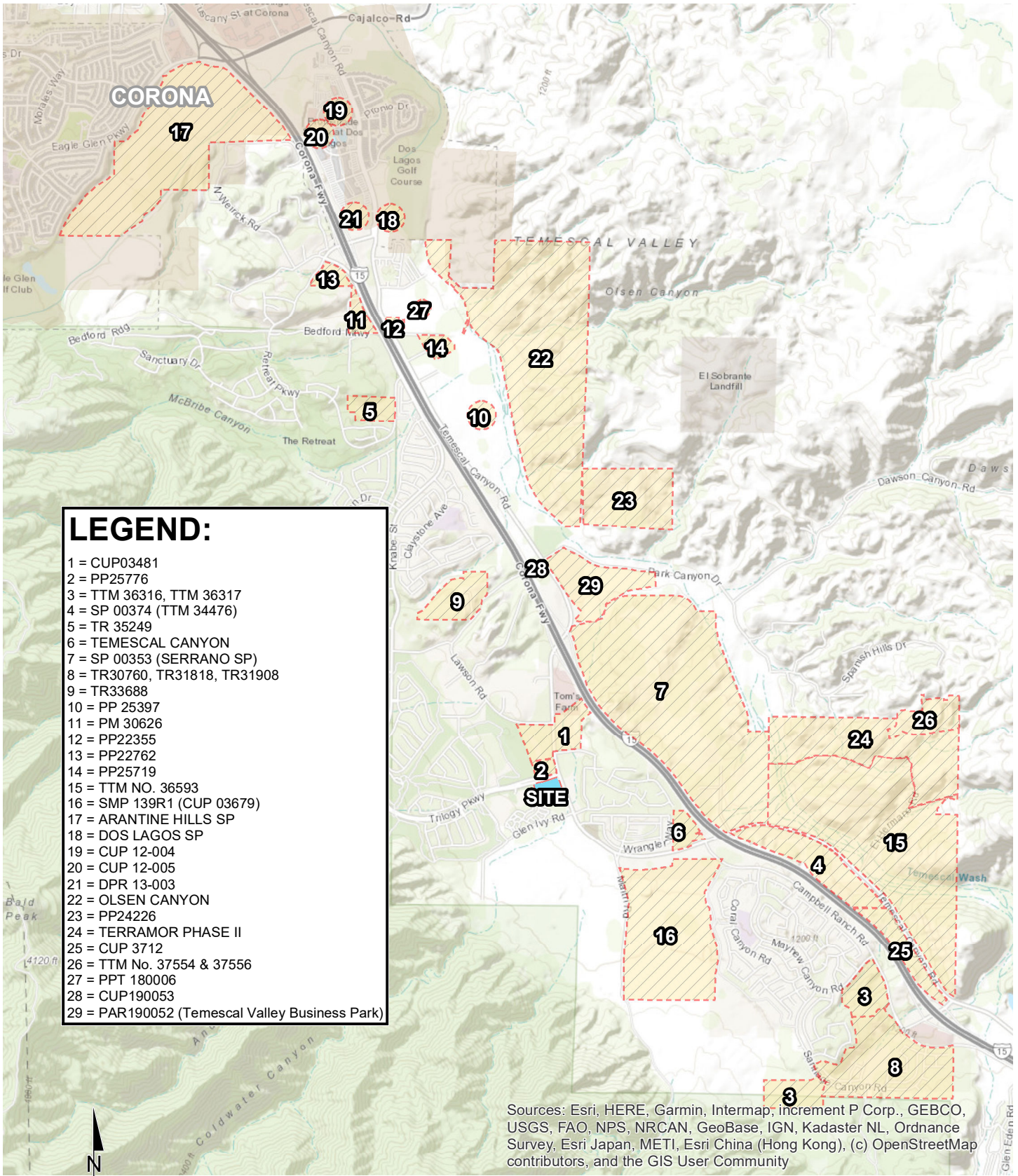



Table 1

Project Trip Generation Summary

Land Use	Units <sup>2</sup>	ITE LU Code	AM Peak Hour			PM Peak Hour			Daily
			In	Out	Total	In	Out	Total	
<b>Trip Generation Rates<sup>1</sup></b>									
Assisted Living	BEDS	254	0.12	0.07	0.19	0.10	0.16	0.26	2.60
Senior Adult Housing - Attached	DU	252	0.07	0.13	0.20	0.14	0.12	0.26	3.70

Land Use	Quantity	Units <sup>2</sup>	AM Peak Hour			PM Peak Hour			Daily
			In	Out	Total	In	Out	Total	
<b>Project Trip Generation Summary</b>									
Assisted Living	144	BEDS	17	10	27	14	23	37	376
Senior Adult Housing - Attached	76	DU	5	10	15	11	9	20	282
<b>Project Buildout Total:</b>			<b>22</b>	<b>20</b>	<b>42</b>	<b>25</b>	<b>32</b>	<b>57</b>	<b>658</b>

<sup>1</sup> Trip Generation Source: Institute of Transportation Engineers (ITE), Trip Generation Manual, Tenth Edition (2017).

<sup>2</sup> DU = Dwelling Units

**Table 2**  
Page 1 of 2

**Cumulative Development Land Use Summary**

#	Project Name	Land Use	Quantity	Units <sup>1</sup>
1	CUP03481	Shopping Center	480.000	TSF
2	PP25776	Church	73.600	TSF
		Private School	216	STU
		Pre-School	96	STU
3	TTM No. 36316	Single Family Residential	87	DU
		Single Family Residential	194	DU
	TTM No. 36317	Passive Park	14.5	AC
		Passive Park	3.9	AC
4	Specific Plan No. 00374 (TTM No. 34476) <sup>2</sup>	Fast Food w/ Drive Thru	3.500	TSF
		Business Park	476.150	TSF
		High Turnover Restaurant	13.460	TSF
		Daycare Center	10.000	TSF
		Hotel	320	ROOMS
		Shopping Center	117.740	TSF
		General Office	103.300	TSF
	Mini-Warehouse	381	UNITS	
5	TR 35249	SFDR	53	DU
6	Temescal Canyon	SFDR	93	DU
7	Specific Plan No. 00353 (Serrano Specific Plan) <sup>3</sup>	Light Industrial	6,600.994	TSF
		Shopping Center	172.150	TSF
8	TR30760	Single Family Residential	285	DU
	TR31818	Single Family Residential	311	DU
		Community Park	11.65	AC
	TR31908	Single Family Residential	261	DU
9	TR33688	Single Family Residential	49	DU
10	PP 25397	Manufacturing	60.300	TSF
11	PM 30626	Business Park	8.7	AC
12	PP22355	Fast Food w/ Drive Thru	2.500	TSF
		Retail	30.214	TSF
13	PP22762	General Office	93.924	TSF
14	PP25719	General Light Industrial	84.892	TSF
15	Specific Plan No. 00327 (Toscana Phase I and Phase III)	SFDR	917	DU
		Active Park	8.1	AC
16	SMP 139R1 (CUP 03679)	Surface Mining	2.0	MTPY
17	Arantine Hills Specific Plan	Single Family Residential	549	DU
		Multi-Family Residential	1,072	DU
		Passive Park	4.0	AC
		Active Park	11.0	AC
		General Office	59.000	TSF
		Business Park	230.900	TSF
		Specialty Retail	59.000	TSF
Shopping Center	396.400	TSF		
18	Dos Lagos Specific Plan	Apartments (PA 1)	450	DU
19	CUP 12-004	Hotel	120	RM
20	CUP 12-005	Apartments	125	DU

**Table 2**  
Page 2 of 2

**Cumulative Development Land Use Summary**

#	Project Name	Land Use	Quantity	Units <sup>1</sup>
21	DPR 13-003	Apartments	354	DU
22	Olsen Canyon	Surface Mining	2.0	MTPY
23	PP24226 (Leinen Business Park)	Manufacturing	135.421	TSF
24	Toscana Phase 2	Single Family Residential	501	DU
		Active Park	5.0	AC
		Passive Park	0.9	AC
25	CUP 3712 (Phase 1 + Phase 2)	Gas Station w/ Market and Car Wash	12	DU
		Fast Food w/ Drive Thru	6.800	TSF
		High Turnover Restaurant	20.000	TSF
		General Office	56.000	TSF
		Shopping Center	46.900	TSF
		Supermarket	43.000	TSF
		Pharmacy w/ Drive Thru	14.000	TSF
Bank w/ Drive Thru	3.500	TSF		
26	TTM No. 37554 & 37556	Single Family Residential	143	DU
27	PPT180006	Warehousing	30.250	TSF
28	CUP190053	Marijuana Dispensary	8.582	TSF
29	PAR190052 (Temescal Valley Business Park)	Industrial Park	1025.766	TSF
		Fast Food w/ Drive Thru	5.400	TSF
		Super Convenience Market/Gas Station	16	VFP

<sup>1</sup> DU = Dwelling Units; TSF = Thousand Square Feet; AC = Acres; MTPY = Million Tons Per Year; STU = Students; RM = Room

<sup>2</sup> Land Use and Quantity Source: Specific Plan No. 00374 (TTM No. 34476) TIA, Urban Crossroads, Inc., August 18, 2008.

<sup>3</sup> Source: Serrano Commerce Center TIA, Kunzman Associates, November 20, 2008.



**APPENDIX 1.2:**  
**SITE ADJACENT QUEUES**

This Page Intentionally Left Blank

**Intersection: 1: Driveway 1 & Trilogy Pkwy**

Movement	WB	NB
Directions Served	L	LR
Maximum Queue (ft)	18	29
Average Queue (ft)	1	4
95th Queue (ft)	8	21
Link Distance (ft)		39
Upstream Blk Time (%)		0
Queuing Penalty (veh)		0
Storage Bay Dist (ft)	100	
Storage Blk Time (%)		
Queuing Penalty (veh)		

**Intersection: 2: Driveway 2 & Trilogy Pkwy**

Movement	NB
Directions Served	R
Maximum Queue (ft)	30
Average Queue (ft)	5
95th Queue (ft)	24
Link Distance (ft)	55
Upstream Blk Time (%)	
Queuing Penalty (veh)	
Storage Bay Dist (ft)	
Storage Blk Time (%)	
Queuing Penalty (veh)	

**Intersection: 4: Temescal Canyon Rd & Trilogy Pkwy**

Movement	EB	EB	NB	NB	NB	SB	SB	SB
Directions Served	L	R	L	T	T	T	T	R
Maximum Queue (ft)	113	43	156	240	235	234	247	135
Average Queue (ft)	47	16	60	137	122	84	101	37
95th Queue (ft)	90	34	125	230	222	185	205	113
Link Distance (ft)	267	267		279	279	1413	1413	
Upstream Blk Time (%)				0	0			
Queuing Penalty (veh)				1	1			
Storage Bay Dist (ft)			155					110
Storage Blk Time (%)				3			9	0
Queuing Penalty (veh)				3			9	0



Intersection: 5: Temescal Canyon Rd & Driveway 3

Movement	EB	NB	NB
Directions Served	R	T	T
Maximum Queue (ft)	12	25	17
Average Queue (ft)	0	2	1
95th Queue (ft)	6	17	14
Link Distance (ft)	119	210	210
Upstream Blk Time (%)			
Queuing Penalty (veh)			
Storage Bay Dist (ft)			
Storage Blk Time (%)			
Queuing Penalty (veh)			

Intersection: 6: Temescal Canyon Rd & Driveway 4

Movement	EB	NB
Directions Served	LR	L
Maximum Queue (ft)	39	24
Average Queue (ft)	9	2
95th Queue (ft)	31	12
Link Distance (ft)	133	
Upstream Blk Time (%)		
Queuing Penalty (veh)		
Storage Bay Dist (ft)		100
Storage Blk Time (%)		
Queuing Penalty (veh)		

Zone Summary

Zone wide Queuing Penalty: 14
-------------------------------

**Intersection: 1: Driveway 1 & Trilogy Pkwy**

Movement	WB	NB
Directions Served	L	LR
Maximum Queue (ft)	24	29
Average Queue (ft)	1	6
95th Queue (ft)	11	26
Link Distance (ft)		39
Upstream Blk Time (%)		0
Queuing Penalty (veh)		0
Storage Bay Dist (ft)	100	
Storage Blk Time (%)		
Queuing Penalty (veh)		

**Intersection: 2: Driveway 2 & Trilogy Pkwy**

Movement	NB
Directions Served	R
Maximum Queue (ft)	30
Average Queue (ft)	11
95th Queue (ft)	34
Link Distance (ft)	55
Upstream Blk Time (%)	
Queuing Penalty (veh)	
Storage Bay Dist (ft)	
Storage Blk Time (%)	
Queuing Penalty (veh)	

**Intersection: 4: Temescal Canyon Rd & Trilogy Pkwy**

Movement	EB	EB	NB	NB	NB	SB	SB	SB
Directions Served	L	R	L	T	T	T	T	R
Maximum Queue (ft)	194	76	136	172	140	289	306	135
Average Queue (ft)	100	28	63	78	51	129	150	55
95th Queue (ft)	163	59	109	132	108	258	288	135
Link Distance (ft)	267	267		279	279	1413	1413	
Upstream Blk Time (%)				0				
Queuing Penalty (veh)				0				
Storage Bay Dist (ft)			155					110
Storage Blk Time (%)			0	0		10	0	
Queuing Penalty (veh)			1	0		16	0	

Intersection: 5: Temescal Canyon Rd & Driveway 3

Movement	EB
Directions Served	R
Maximum Queue (ft)	30
Average Queue (ft)	3
95th Queue (ft)	19
Link Distance (ft)	119
Upstream Blk Time (%)	
Queuing Penalty (veh)	
Storage Bay Dist (ft)	
Storage Blk Time (%)	
Queuing Penalty (veh)	

Intersection: 6: Temescal Canyon Rd & Driveway 4

Movement	EB	NB
Directions Served	LR	L
Maximum Queue (ft)	40	22
Average Queue (ft)	12	2
95th Queue (ft)	38	14
Link Distance (ft)	133	
Upstream Blk Time (%)		
Queuing Penalty (veh)		
Storage Bay Dist (ft)		100
Storage Blk Time (%)		
Queuing Penalty (veh)		

Zone Summary

Zone wide Queuing Penalty: 17



**APPENDIX 3.1:**

**EXISTING TRAFFIC COUNTS – SEPTEMBER 2018 & NOVEMBER 2019**

This Page Intentionally Left Blank

County of Riverside  
 N/S: Temescal Canyon Road  
 E/W: Lawson Road  
 Weather: Clear

File Name : 04\_CRV\_Temescal Canyon\_Lawson AM  
 Site Code : 05118715  
 Start Date : 9/27/2018  
 Page No : 1

Groups Printed- Total Volume

Start Time	Temescal Canyon Road Southbound			Temescal Canyon Road Northbound			Lawson Road Eastbound			Int. Total
	Thru	Right	App. Total	Left	Thru	App. Total	Left	Right	App. Total	
07:00 AM	61	7	68	21	268	289	17	2	19	376
07:15 AM	79	3	82	13	208	221	9	1	10	313
07:30 AM	86	14	100	16	191	207	18	3	21	328
07:45 AM	88	8	96	25	136	161	9	3	12	269
Total	314	32	346	75	803	878	53	9	62	1286
08:00 AM	59	19	78	54	123	177	8	1	9	264
08:15 AM	92	10	102	40	142	182	9	6	15	299
08:30 AM	81	10	91	30	138	168	13	15	28	287
08:45 AM	93	11	104	20	119	139	6	8	14	257
Total	325	50	375	144	522	666	36	30	66	1107
Grand Total	639	82	721	219	1325	1544	89	39	128	2393
Apprch %	88.6	11.4		14.2	85.8		69.5	30.5		
Total %	26.7	3.4	30.1	9.2	55.4	64.5	3.7	1.6	5.3	

Start Time	Temescal Canyon Road Southbound			Temescal Canyon Road Northbound			Lawson Road Eastbound			Int. Total
	Thru	Right	App. Total	Left	Thru	App. Total	Left	Right	App. Total	
Peak Hour Analysis From 07:00 AM to 08:45 AM - Peak 1 of 1										
Peak Hour for Entire Intersection Begins at 07:00 AM										
07:00 AM	61	7	68	21	<b>268</b>	<b>289</b>	17	2	19	<b>376</b>
07:15 AM	79	3	82	13	208	221	9	1	10	313
07:30 AM	86	<b>14</b>	<b>100</b>	16	191	207	<b>18</b>	<b>3</b>	<b>21</b>	328
07:45 AM	<b>88</b>	8	96	<b>25</b>	136	161	9	3	12	269
Total Volume	314	32	346	75	803	878	53	9	62	1286
% App. Total	90.8	9.2		8.5	91.5		85.5	14.5		
PHF	.892	.571	.865	.750	.749	.760	.736	.750	.738	.855



County of Riverside  
 N/S: Temescal Canyon Road  
 E/W: Lawson Road  
 Weather: Clear

File Name : 04\_CRV\_Temescal Canyon\_Lawson AM  
 Site Code : 05118715  
 Start Date : 9/27/2018  
 Page No : 2

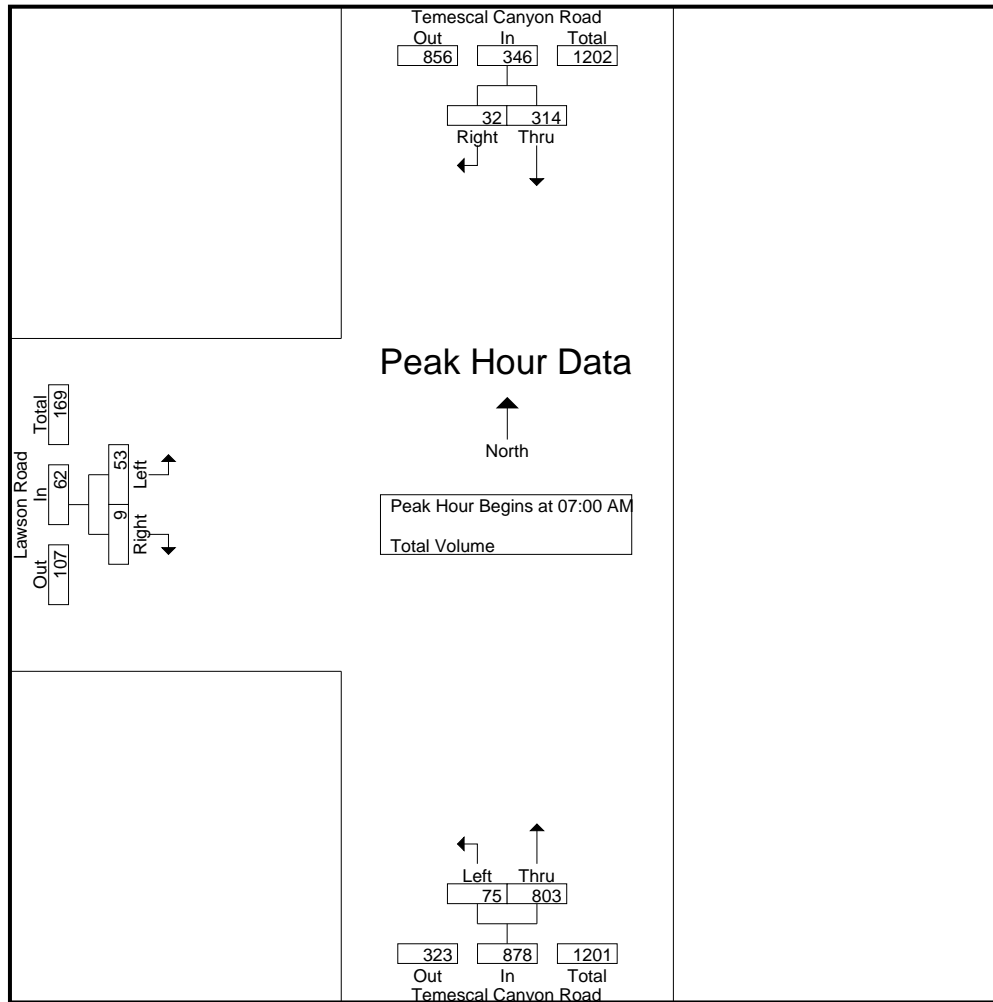

Peak Hour Analysis From 07:00 AM to 08:45 AM - Peak 1 of 1  
 Peak Hour for Each Approach Begins at:

	07:30 AM			07:00 AM			08:00 AM		
+0 mins.	86	14	100	21	<b>268</b>	<b>289</b>	8	1	9
+15 mins.	88	8	96	13	208	221	9	6	15
+30 mins.	59	<b>19</b>	78	16	191	207	<b>13</b>	<b>15</b>	<b>28</b>
+45 mins.	<b>92</b>	10	<b>102</b>	<b>25</b>	136	161	6	8	14
Total Volume	325	51	376	75	803	878	36	30	66
% App. Total	86.4	13.6		8.5	91.5		54.5	45.5	
PHF	.883	.671	.922	.750	.749	.760	.692	.500	.589

County of Riverside  
 N/S: Temescal Canyon Road  
 E/W: Lawson Road  
 Weather: Clear

File Name : 04\_CRV\_Temescal Canyon\_Lawson PM  
 Site Code : 05118715  
 Start Date : 9/27/2018  
 Page No : 1

Groups Printed- Total Volume

Start Time	Temescal Canyon Road Southbound			Temescal Canyon Road Northbound			Lawson Road Eastbound			Int. Total
	Thru	Right	App. Total	Left	Thru	App. Total	Left	Right	App. Total	
04:00 PM	119	13	132	8	125	133	12	5	17	282
04:15 PM	110	12	122	3	93	96	9	7	16	234
04:30 PM	116	23	139	9	103	112	10	8	18	269
04:45 PM	138	13	151	5	98	103	8	3	11	265
Total	483	61	544	25	419	444	39	23	62	1050
05:00 PM	142	19	161	10	101	111	13	2	15	287
05:15 PM	125	16	141	2	98	100	5	7	12	253
05:30 PM	122	15	137	7	87	94	6	3	9	240
05:45 PM	127	24	151	8	78	86	11	5	16	253
Total	516	74	590	27	364	391	35	17	52	1033
Grand Total	999	135	1134	52	783	835	74	40	114	2083
Apprch %	88.1	11.9		6.2	93.8		64.9	35.1		
Total %	48	6.5	54.4	2.5	37.6	40.1	3.6	1.9	5.5	

Start Time	Temescal Canyon Road Southbound			Temescal Canyon Road Northbound			Lawson Road Eastbound			Int. Total
	Thru	Right	App. Total	Left	Thru	App. Total	Left	Right	App. Total	
Peak Hour Analysis From 04:00 PM to 05:45 PM - Peak 1 of 1										
Peak Hour for Entire Intersection Begins at 04:30 PM										
04:30 PM	116	<b>23</b>	139	9	<b>103</b>	<b>112</b>	10	<b>8</b>	<b>18</b>	269
04:45 PM	138	13	151	5	98	103	8	3	11	265
05:00 PM	<b>142</b>	19	<b>161</b>	<b>10</b>	101	111	<b>13</b>	2	15	<b>287</b>
05:15 PM	125	16	141	2	98	100	5	7	12	253
Total Volume	521	71	592	26	400	426	36	20	56	1074
% App. Total	88	12		6.1	93.9		64.3	35.7		
PHF	.917	.772	.919	.650	.971	.951	.692	.625	.778	.936

County of Riverside  
 N/S: Temescal Canyon Road  
 E/W: Lawson Road  
 Weather: Clear

File Name : 04\_CRV\_Temescal Canyon\_Lawson PM  
 Site Code : 05118715  
 Start Date : 9/27/2018  
 Page No : 2

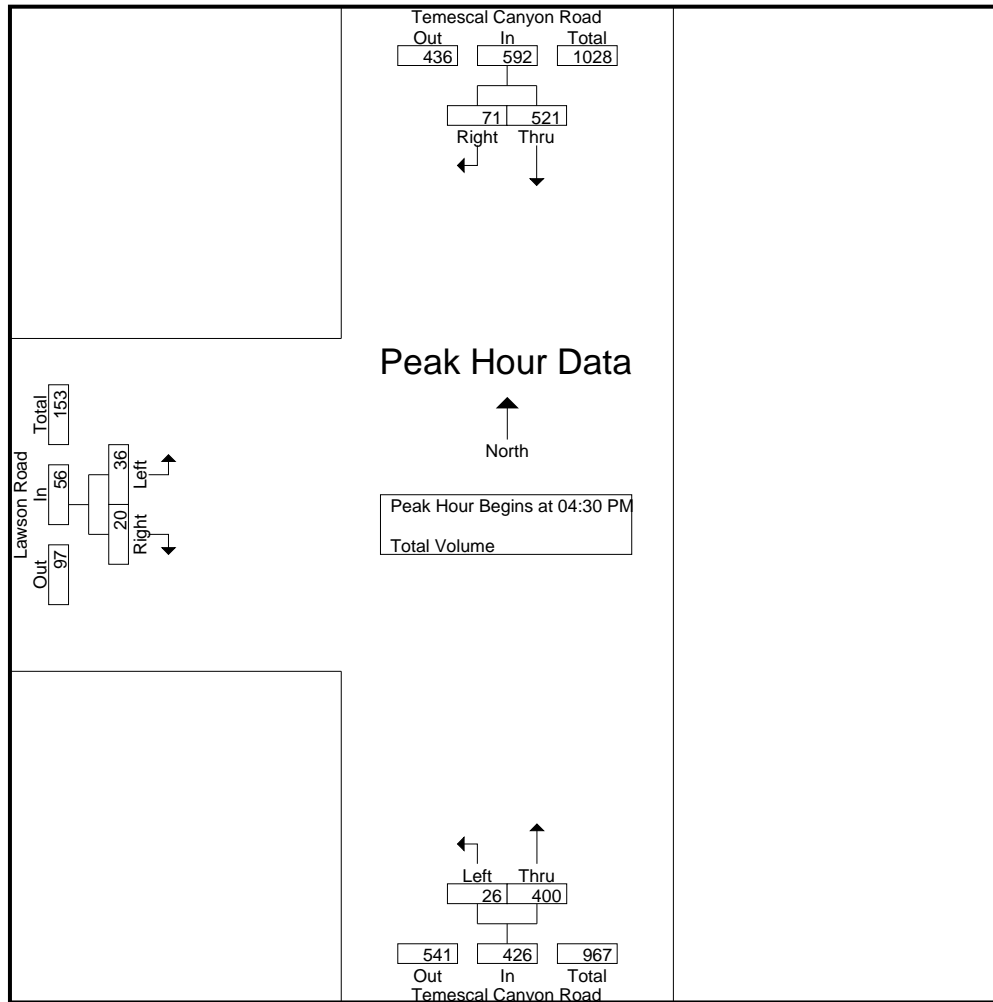

Peak Hour Analysis From 04:00 PM to 05:45 PM - Peak 1 of 1  
 Peak Hour for Each Approach Begins at:

	04:30 PM			04:00 PM			04:00 PM		
+0 mins.	116	<b>23</b>	139	8	<b>125</b>	<b>133</b>	<b>12</b>	5	17
+15 mins.	138	13	151	3	93	96	9	7	16
+30 mins.	<b>142</b>	19	<b>161</b>	<b>9</b>	103	112	10	<b>8</b>	<b>18</b>
+45 mins.	125	16	141	5	98	103	8	3	11
Total Volume	521	71	592	25	419	444	39	23	62
% App. Total	88	12		5.6	94.4		62.9	37.1	
PHF	.917	.772	.919	.694	.838	.835	.813	.719	.861



Location: County of Riverside  
 N/S: Temescal Canyon Road  
 E/W: Lawson Road



Date: 9/27/2018  
 Day: Thursday

PEDESTRIANS

	North Leg Temescal Canyon Road	East Leg Dead End	South Leg Temescal Canyon Road	West Leg Lawson Road	
	Pedestrians	Pedestrians	Pedestrians	Pedestrians	
7:00 AM	0	0	0	0	0
7:15 AM	0	0	0	0	0
7:30 AM	0	0	0	0	0
7:45 AM	0	0	0	0	0
8:00 AM	0	0	0	0	0
8:15 AM	0	0	0	0	0
8:30 AM	0	0	0	0	0
8:45 AM	0	0	0	0	0
TOTAL VOLUMES:	0	0	0	0	0

	North Leg Temescal Canyon Road	East Leg Dead End	South Leg Temescal Canyon Road	West Leg Lawson Road	
	Pedestrians	Pedestrians	Pedestrians	Pedestrians	
4:00 PM	0	0	0	0	0
4:15 PM	0	0	0	0	0
4:30 PM	0	0	0	0	0
4:45 PM	0	0	0	0	0
5:00 PM	0	0	0	0	0
5:15 PM	0	0	0	0	0
5:30 PM	0	0	0	0	0
5:45 PM	0	0	1	0	1
TOTAL VOLUMES:	0	0	1	0	1

Location: County of Riverside  
 N/S: Temescal Canyon Road  
 E/W: Lawson Road



Date: 9/27/2018  
 Day: Thursday

BICYCLES

	Southbound Temescal Canyon Road			Westbound Dead End			Northbound Temescal Canyon Road			Eastbound Lawson Road			
	Left	Thru	Right	Left	Thru	Right	Left	Thru	Right	Left	Thru	Right	
7:00 AM	0	0	0	0	0	0	0	0	0	0	0	0	0
7:15 AM	0	0	0	0	0	0	0	0	0	0	0	0	0
7:30 AM	0	0	0	0	0	0	0	0	0	0	0	0	0
7:45 AM	0	0	0	0	0	0	0	0	0	0	0	0	0
8:00 AM	0	0	0	0	0	0	0	0	0	0	0	0	0
8:15 AM	0	0	0	0	0	0	0	1	0	0	0	0	1
8:30 AM	0	1	0	0	0	0	0	0	0	0	0	0	1
8:45 AM	0	0	0	0	0	0	0	0	0	0	0	0	0
TOTAL VOLUMES:	0	1	0	0	0	0	0	1	0	0	0	0	2

	Southbound Temescal Canyon Road			Westbound Dead End			Northbound Temescal Canyon Road			Eastbound Lawson Road			
	Left	Thru	Right	Left	Thru	Right	Left	Thru	Right	Left	Thru	Right	
4:00 PM	0	0	0	0	0	0	0	0	0	0	0	0	0
4:15 PM	0	0	0	0	0	0	0	0	0	0	0	0	0
4:30 PM	0	0	0	0	0	0	0	0	0	0	0	0	0
4:45 PM	0	0	0	0	0	0	0	0	0	0	0	0	0
5:00 PM	0	0	0	0	0	0	0	0	0	0	0	0	0
5:15 PM	0	0	0	0	0	0	0	0	0	0	0	0	0
5:30 PM	0	0	0	0	0	0	0	0	0	0	0	0	0
5:45 PM	0	0	0	0	0	0	0	0	0	0	0	0	0
TOTAL VOLUMES:	0	0	0	0	0	0	0	0	0	0	0	0	0





**AimTD LLC**  
TURNING MOVEMENT COUNTS

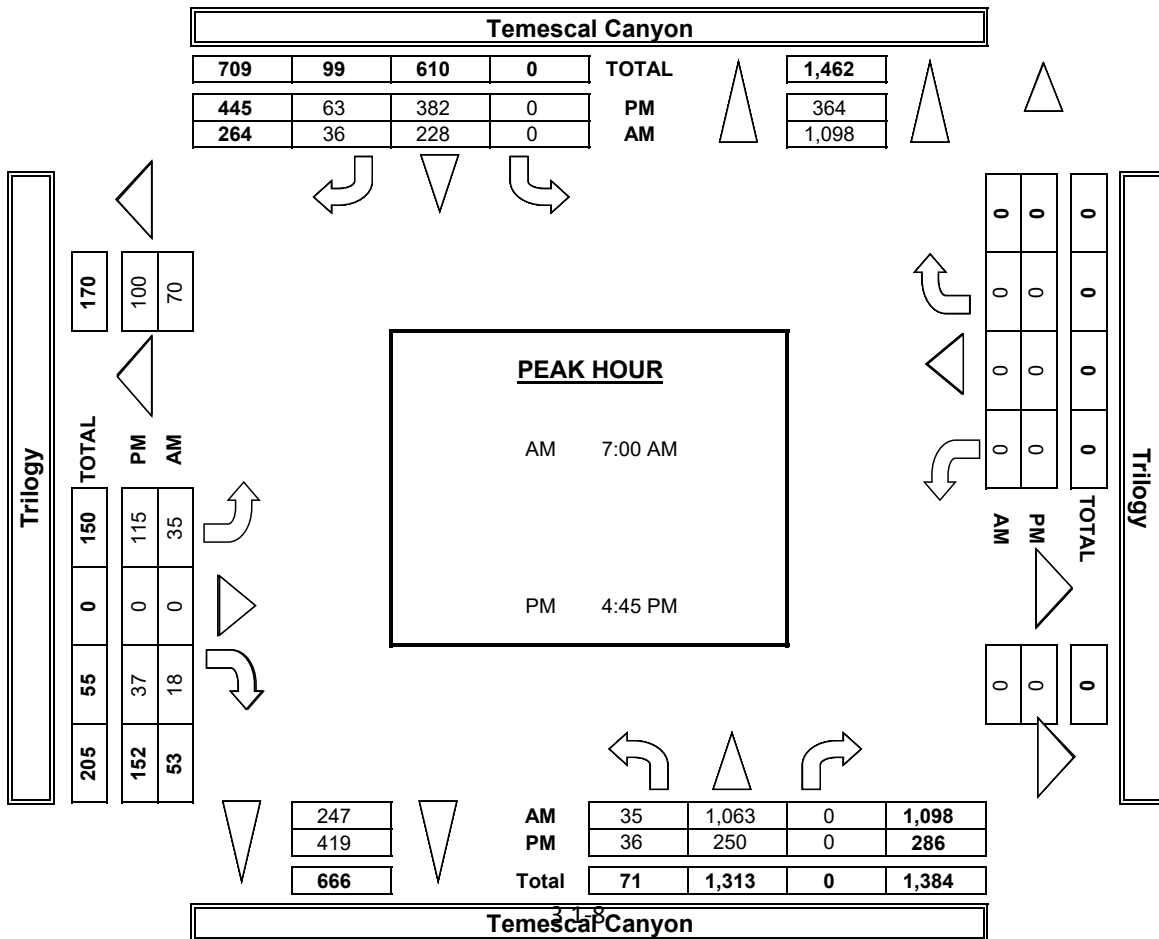
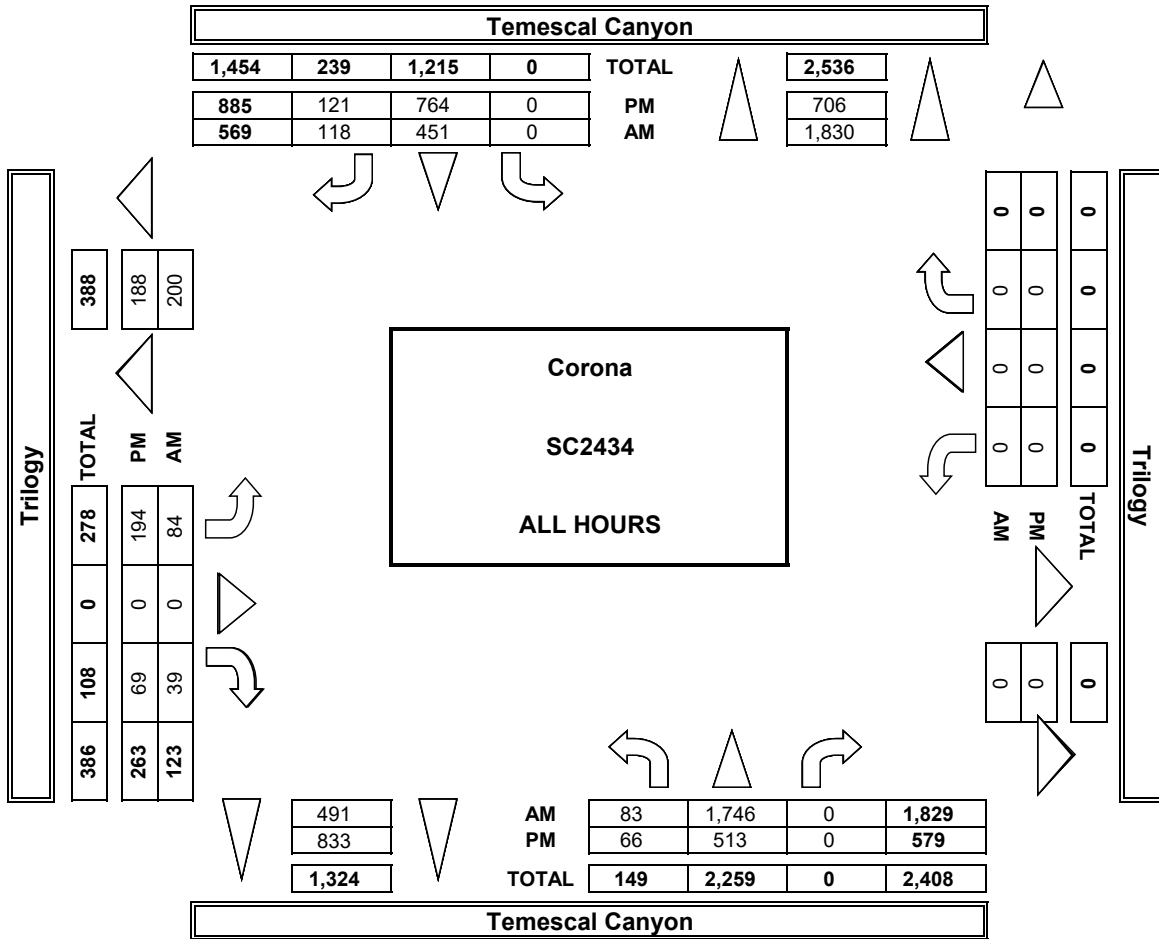

**APPENDIX 3.2:**

**EXISTING (2020) CONDITIONS INTERSECTION OPERATIONS ANALYSIS WORKSHEETS**

This Page Intentionally Left Blank



Intersection						
Int Delay, s/veh	1.7					
Movement	EBL	EBR	NBL	NBT	SBT	SBR
Lane Configurations						
Traffic Vol, veh/h	55	9	96	1023	327	33
Future Vol, veh/h	55	9	96	1023	327	33
Conflicting Peds, #/hr	0	0	0	0	0	0
Sign Control	Stop	Stop	Free	Free	Free	Free
RT Channelized	-	None	-	None	-	None
Storage Length	0	-	200	-	-	-
Veh in Median Storage, #	2	-	-	0	0	-
Grade, %	0	-	-	0	0	-
Peak Hour Factor	86	86	86	86	86	86
Heavy Vehicles, %	0	0	0	0	0	0
Mvmt Flow	64	10	112	1190	380	38

Major/Minor	Minor2	Major1	Major2			
Conflicting Flow All	1813	399	418	0	-	0
Stage 1	399	-	-	-	-	-
Stage 2	1414	-	-	-	-	-
Critical Hdwy	6.4	6.2	4.1	-	-	-
Critical Hdwy Stg 1	5.4	-	-	-	-	-
Critical Hdwy Stg 2	5.4	-	-	-	-	-
Follow-up Hdwy	3.5	3.3	2.2	-	-	-
Pot Cap-1 Maneuver	87	655	1152	-	-	-
Stage 1	682	-	-	-	-	-
Stage 2	227	-	-	-	-	-
Platoon blocked, %				-	-	-
Mov Cap-1 Maneuver	79	655	1152	-	-	-
Mov Cap-2 Maneuver	208	-	-	-	-	-
Stage 1	616	-	-	-	-	-
Stage 2	227	-	-	-	-	-

Approach	EB	NB	SB
HCM Control Delay, s	28	0.7	0
HCM LOS	D		

Minor Lane/Major Mvmt	NBL	NBT	EBLn1	SBT	SBR
Capacity (veh/h)	1152	-	230	-	-
HCM Lane V/C Ratio	0.097	-	0.324	-	-
HCM Control Delay (s)	8.5	-	28	-	-
HCM Lane LOS	A	-	D	-	-
HCM 95th %tile Q(veh)	0.3	-	1.3	-	-

Timings  
4: Temescal Canyon Rd & Trilogy Pkwy



Lane Group	EBL	EBR	NBL	NBT	SBT	SBR
Lane Configurations	↖	↗	↖	↗	↗	↖
Traffic Volume (vph)	36	18	36	1084	291	46
Future Volume (vph)	36	18	36	1084	291	46
Turn Type	Prot	Perm	Prot	NA	NA	Perm
Protected Phases	4		5	2	6	
Permitted Phases		4				6
Detector Phase	4	4	5	2	6	6
Switch Phase						
Minimum Initial (s)	10.0	10.0	5.0	10.0	10.0	10.0
Minimum Split (s)	28.8	28.8	9.6	15.4	33.4	33.4
Total Split (s)	28.8	28.8	10.0	61.2	51.2	51.2
Total Split (%)	32.0%	32.0%	11.1%	68.0%	56.9%	56.9%
Yellow Time (s)	4.8	4.8	3.6	4.4	4.4	4.4
All-Red Time (s)	1.0	1.0	1.0	1.0	1.0	1.0
Lost Time Adjust (s)	-1.8	-1.8	-0.6	-1.4	-1.4	-1.4
Total Lost Time (s)	4.0	4.0	4.0	4.0	4.0	4.0
Lead/Lag			Lead		Lag	Lag
Lead-Lag Optimize?			Yes		Yes	Yes
Recall Mode	None	None	None	None	None	None

Intersection Summary

Cycle Length: 90  
 Actuated Cycle Length: 58.4  
 Natural Cycle: 90  
 Control Type: Actuated-Uncoordinated

Splits and Phases: 4: Temescal Canyon Rd & Trilogy Pkwy



HCM 6th Signalized Intersection Summary  
4: Temescal Canyon Rd & Trilogy Pkwy

Glen Ivy Senior Living (JN 13030)  
09/03/2020



Movement	EBL	EBR	NBL	NBT	SBT	SBR
Lane Configurations						
Traffic Volume (veh/h)	36	18	36	1084	291	46
Future Volume (veh/h)	36	18	36	1084	291	46
Initial Q (Qb), veh	0	0	0	0	0	0
Ped-Bike Adj(A_pbT)	1.00	1.00	1.00			1.00
Parking Bus, Adj	1.00	1.00	1.00	1.00	1.00	1.00
Work Zone On Approach	No			No	No	
Adj Sat Flow, veh/h/ln	1900	1900	1900	1900	1900	1900
Adj Flow Rate, veh/h	37	6	37	1106	297	45
Peak Hour Factor	0.98	0.98	0.98	0.98	0.98	0.98
Percent Heavy Veh, %	0	0	0	0	0	0
Cap, veh/h	230	205	95	1348	1092	926
Arrive On Green	0.13	0.13	0.05	0.71	0.57	0.57
Sat Flow, veh/h	1810	1610	1810	1900	1900	1610
Grp Volume(v), veh/h	37	6	37	1106	297	45
Grp Sat Flow(s),veh/h/ln	1810	1610	1810	1900	1900	1610
Q Serve(g_s), s	0.9	0.2	1.0	19.8	3.9	0.6
Cycle Q Clear(g_c), s	0.9	0.2	1.0	19.8	3.9	0.6
Prop In Lane	1.00	1.00	1.00			1.00
Lane Grp Cap(c), veh/h	230	205	95	1348	1092	926
V/C Ratio(X)	0.16	0.03	0.39	0.82	0.27	0.05
Avail Cap(c_a), veh/h	917	816	222	2221	1833	1553
HCM Platoon Ratio	1.00	1.00	1.00	1.00	1.00	1.00
Upstream Filter(I)	1.00	1.00	1.00	1.00	1.00	1.00
Uniform Delay (d), s/veh	19.0	18.7	22.4	4.9	5.2	4.5
Incr Delay (d2), s/veh	0.3	0.1	1.0	1.3	0.1	0.0
Initial Q Delay(d3),s/veh	0.0	0.0	0.0	0.0	0.0	0.0
%ile BackOfQ(50%),veh/ln	0.3	0.0	0.4	2.1	0.9	0.1
Unsig. Movement Delay, s/veh						
LnGrp Delay(d),s/veh	19.3	18.8	23.4	6.2	5.4	4.6
LnGrp LOS	B	B	C	A	A	A
Approach Vol, veh/h	43			1143	342	
Approach Delay, s/veh	19.3			6.8	5.3	
Approach LOS	B			A	A	
Timer - Assigned Phs		2		4	5	6
Phs Duration (G+Y+Rc), s		38.7		10.2	6.6	32.1
Change Period (Y+Rc), s		5.4		5.8	4.6	5.4
Max Green Setting (Gmax), s		55.8		23.0	5.4	45.8
Max Q Clear Time (g_c+I1), s		21.8		2.9	3.0	5.9
Green Ext Time (p_c), s		11.5		0.1	0.0	1.9
<b>Intersection Summary</b>						
HCM 6th Ctrl Delay			6.8			
HCM 6th LOS			A			



Intersection						
Int Delay, s/veh	0.9					
Movement	EBL	EBR	NBL	NBT	SBT	SBR
Lane Configurations	Y		Y	↑	↑	
Traffic Vol, veh/h	37	21	27	416	542	74
Future Vol, veh/h	37	21	27	416	542	74
Conflicting Peds, #/hr	0	0	0	0	0	0
Sign Control	Stop	Stop	Free	Free	Free	Free
RT Channelized	-	None	-	None	-	None
Storage Length	0	-	200	-	-	-
Veh in Median Storage, #	2	-	-	0	0	-
Grade, %	0	-	-	0	0	-
Peak Hour Factor	94	94	94	94	94	94
Heavy Vehicles, %	0	0	0	0	0	0
Mvmt Flow	39	22	29	443	577	79

Major/Minor	Minor2	Major1	Major2			
Conflicting Flow All	1118	617	656	0	-	0
Stage 1	617	-	-	-	-	-
Stage 2	501	-	-	-	-	-
Critical Hdwy	6.4	6.2	4.1	-	-	-
Critical Hdwy Stg 1	5.4	-	-	-	-	-
Critical Hdwy Stg 2	5.4	-	-	-	-	-
Follow-up Hdwy	3.5	3.3	2.2	-	-	-
Pot Cap-1 Maneuver	231	494	941	-	-	-
Stage 1	542	-	-	-	-	-
Stage 2	613	-	-	-	-	-
Platoon blocked, %				-	-	-
Mov Cap-1 Maneuver	224	494	941	-	-	-
Mov Cap-2 Maneuver	426	-	-	-	-	-
Stage 1	525	-	-	-	-	-
Stage 2	613	-	-	-	-	-

Approach	EB	NB	SB
HCM Control Delay, s	14.3	0.5	0
HCM LOS	B		

Minor Lane/Major Mvmt	NBL	NBT	EBLn1	SBT	SBR
Capacity (veh/h)	941	-	448	-	-
HCM Lane V/C Ratio	0.031	-	0.138	-	-
HCM Control Delay (s)	8.9	-	14.3	-	-
HCM Lane LOS	A	-	B	-	-
HCM 95th %tile Q(veh)	0.1	-	0.5	-	-

Timings  
4: Temescal Canyon Rd & Trilogy Pkwy



Lane Group	EBL	EBR	NBL	NBT	SBT	SBR
Lane Configurations	↖	↖	↖	↑	↑	↖
Traffic Volume (vph)	139	38	37	304	484	79
Future Volume (vph)	139	38	37	304	484	79
Turn Type	Prot	Perm	Prot	NA	NA	Perm
Protected Phases	4		5	2	6	
Permitted Phases		4				6
Detector Phase	4	4	5	2	6	6
Switch Phase						
Minimum Initial (s)	10.0	10.0	5.0	10.0	10.0	10.0
Minimum Split (s)	28.8	28.8	9.6	15.4	33.4	33.4
Total Split (s)	31.0	31.0	11.0	59.0	48.0	48.0
Total Split (%)	34.4%	34.4%	12.2%	65.6%	53.3%	53.3%
Yellow Time (s)	4.8	4.8	3.6	4.4	4.4	4.4
All-Red Time (s)	1.0	1.0	1.0	1.0	1.0	1.0
Lost Time Adjust (s)	-1.8	-1.8	-0.6	-1.4	-1.4	-1.4
Total Lost Time (s)	4.0	4.0	4.0	4.0	4.0	4.0
Lead/Lag			Lead		Lag	Lag
Lead-Lag Optimize?			Yes		Yes	Yes
Recall Mode	None	None	None	None	None	None

Intersection Summary

Cycle Length: 90  
 Actuated Cycle Length: 45.2  
 Natural Cycle: 75  
 Control Type: Actuated-Uncoordinated

Splits and Phases: 4: Temescal Canyon Rd & Trilogy Pkwy



HCM 6th Signalized Intersection Summary  
 4: Temescal Canyon Rd & Trilogy Pkwy

Glen Ivy Senior Living (JN 13030)  
 09/03/2020



Movement	EBL	EBR	NBL	NBT	SBT	SBR
Lane Configurations						
Traffic Volume (veh/h)	139	38	37	304	484	79
Future Volume (veh/h)	139	38	37	304	484	79
Initial Q (Qb), veh	0	0	0	0	0	0
Ped-Bike Adj(A_pbT)	1.00	1.00	1.00			0.98
Parking Bus, Adj	1.00	1.00	1.00	1.00	1.00	1.00
Work Zone On Approach	No			No	No	
Adj Sat Flow, veh/h/ln	1900	1900	1900	1900	1900	1900
Adj Flow Rate, veh/h	145	24	39	317	504	70
Peak Hour Factor	0.96	0.96	0.96	0.96	0.96	0.96
Percent Heavy Veh, %	0	0	0	0	0	0
Cap, veh/h	461	410	106	1040	741	614
Arrive On Green	0.25	0.25	0.06	0.55	0.39	0.39
Sat Flow, veh/h	1810	1610	1810	1900	1900	1576
Grp Volume(v), veh/h	145	24	39	317	504	70
Grp Sat Flow(s),veh/h/ln	1810	1610	1810	1900	1900	1576
Q Serve(g_s), s	2.6	0.5	0.8	3.7	8.9	1.1
Cycle Q Clear(g_c), s	2.6	0.5	0.8	3.7	8.9	1.1
Prop In Lane	1.00	1.00	1.00			1.00
Lane Grp Cap(c), veh/h	461	410	106	1040	741	614
V/C Ratio(X)	0.31	0.06	0.37	0.30	0.68	0.11
Avail Cap(c_a), veh/h	1208	1075	313	2584	2067	1715
HCM Platoon Ratio	1.00	1.00	1.00	1.00	1.00	1.00
Upstream Filter(I)	1.00	1.00	1.00	1.00	1.00	1.00
Uniform Delay (d), s/veh	12.2	11.4	18.3	5.0	10.2	7.9
Incr Delay (d2), s/veh	0.4	0.1	0.8	0.2	1.1	0.1
Initial Q Delay(d3),s/veh	0.0	0.0	0.0	0.0	0.0	0.0
%ile BackOfQ(50%),veh/ln	0.8	0.0	0.3	0.7	2.6	0.3
Unsig. Movement Delay, s/veh						
LnGrp Delay(d),s/veh	12.6	11.5	19.1	5.1	11.4	8.0
LnGrp LOS	B	B	B	A	B	A
Approach Vol, veh/h				356	574	
Approach Delay, s/veh				6.7	10.9	
Approach LOS				A	B	
Timer - Assigned Phs		2		4	5	6
Phs Duration (G+Y+Rc), s		26.1		14.3	6.4	19.8
Change Period (Y+Rc), s		5.4		5.8	4.6	5.4
Max Green Setting (Gmax), s		53.6		25.2	6.4	42.6
Max Q Clear Time (g_c+11), s		5.7		4.6	2.8	10.9
Green Ext Time (p_c), s		1.9		0.4	0.0	3.5
<b>Intersection Summary</b>						
HCM 6th Ctrl Delay			9.8			
HCM 6th LOS			A			



**APPENDIX 3.3:**

**EXISTING (2020) CONDITIONS TRAFFIC SIGNAL WARRANT ANALYSIS WORKSHEETS**

This Page Intentionally Left Blank

### Figure 4C-4. Warrant 3, Peak Hour (70% Factor)

(COMMUNITY LESS THAN 10,000 POPULATION OR ABOVE 64 km/h OR ABOVE 40 mph ON MAJOR STREET)

Traffic Conditions = Existing (2020) Conditions - Weekday AM Peak Hour

Major Street Name = Temescal Canyon Rd. Total of Both Approaches (VPH) = 1479  
 Number of Approach Lanes Major Street = 1

Minor Street Name = Lawson Rd. High Volume Approach (VPH) = 64  
 Number of Approach Lanes Minor Street = 1

SIGNAL WARRANT NOT SATISFIED

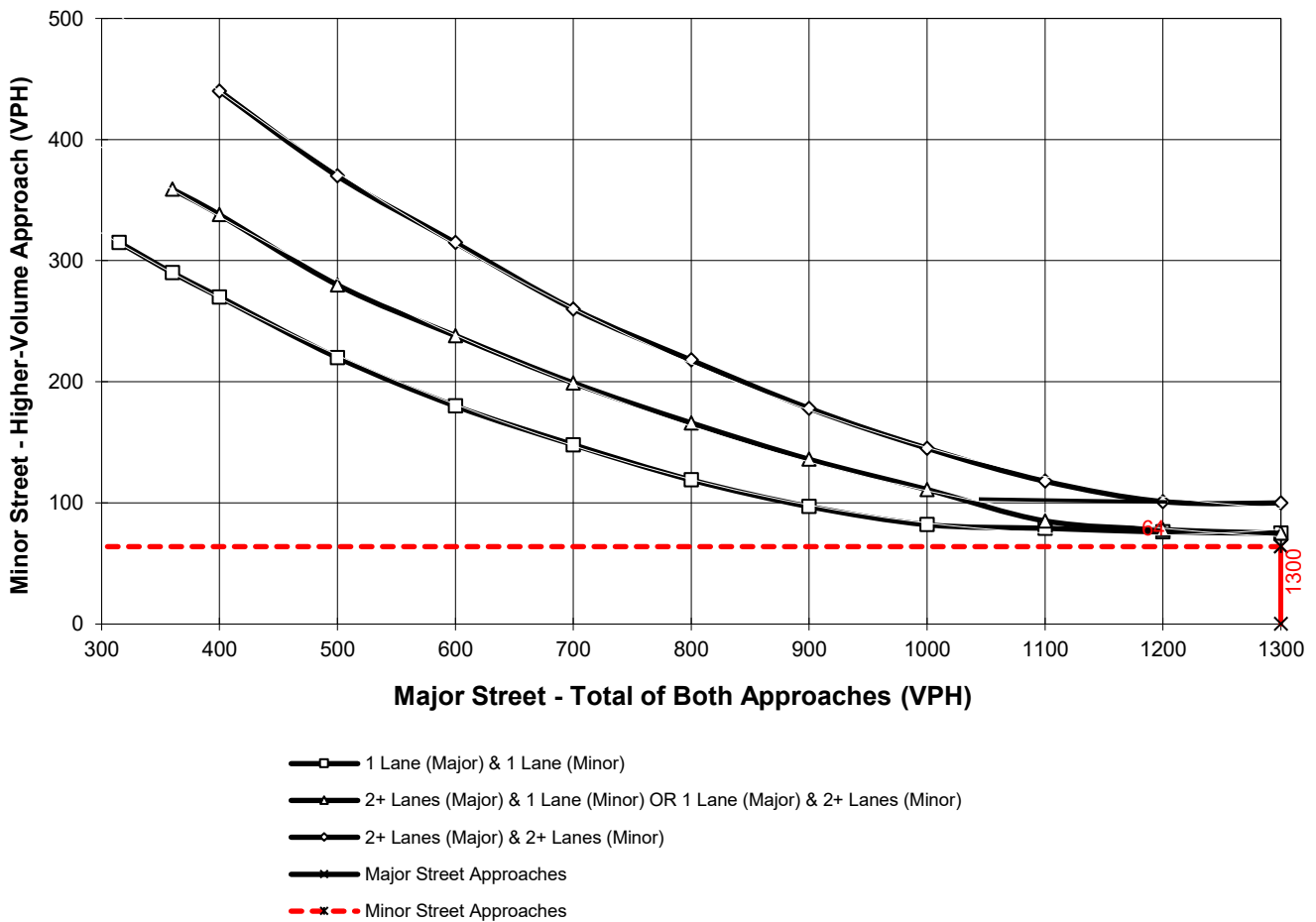

\*Note: 100 vph applies as the lower threshold for a minor-street approach with two or more lanes and 75 vph applies as the lower threshold for a minor-street approach with one lane



This Page Intentionally Left Blank

**APPENDIX 4.1:**  
**POST-PROCESSING WORKSHEETS**

This Page Intentionally Left Blank



Project: Glen Ivy Senior Living  
 Scenario: Horizon Year (2040) Without Project

Job #: 13030  
 Analyst: CS  
 Date: 9/3/20

LOCATION: Temescal Canyon Rd. / Lawson Rd.  
 FORECAST YEAR: 2040

INDIVIDUAL TURN VOLUME GROWTH REVIEW									
APPROACH	TURNING MOVEMENT	AM PEAK HOUR INPUT DATA				PM PEAK HOUR INPUT DATA			
		EXISTING COUNT	FUTURE VOLUME	DIFFERENCE	% CHANGE	EXISTING COUNT	FUTURE VOLUME	DIFFERENCE	% CHANGE
NORTH BOUND	Left	96	105	9	9%	27	81	54	199%
	Through	1,023	1,015	-8	-1%	416	493	77	18%
	Right	0	0	0	#DIV/0!	0	0	0	#DIV/0!
	<b>NB Total</b>	<b>1,119</b>	<b>1,120</b>	<b>1</b>	<b>0%</b>	<b>443</b>	<b>574</b>	<b>131</b>	<b>30%</b>
SOUTH BOUND	Left	0	0	0	#DIV/0!	0	0	0	#DIV/0!
	Through	327	553	226	69%	542	550	8	1%
	Right	33	25	-8	-25%	74	86	12	16%
	<b>SB Total</b>	<b>360</b>	<b>578</b>	<b>218</b>	<b>61%</b>	<b>616</b>	<b>636</b>	<b>20</b>	<b>3%</b>
EAST BOUND	Left	55	65	10	18%	37	27	-10	-28%
	Through	0	0	0	#DIV/0!	0	0	0	#DIV/0!
	Right	9	27	18	188%	21	33	12	59%
	<b>EB Total</b>	<b>65</b>	<b>92</b>	<b>27</b>	<b>43%</b>	<b>58</b>	<b>60</b>	<b>2</b>	<b>3%</b>
WEST BOUND	Left	0	0	0	#DIV/0!	0	0	0	#DIV/0!
	Through	0	0	0	#DIV/0!	0	0	0	#DIV/0!
	Right	0	0	0	#DIV/0!	0	0	0	#DIV/0!
	<b>WB Total</b>	<b>0</b>	<b>0</b>	<b>0</b>	<b>#DIV/0!</b>	<b>0</b>	<b>0</b>	<b>0</b>	<b>#DIV/0!</b>
<b>TOTAL ENTERING VOLUME</b>		<b>1,544</b>	<b>1,790</b>	<b>246.0456</b>	<b>16%</b>	<b>1,117</b>	<b>1,270</b>	<b>153</b>	<b>14%</b>

FORECAST PEAK HOUR TO ADT COMPARISON						
		VOLUMES		PERCENT OF ADT		ADT
		AM	PM	AM	PM	
North Leg	Inbound	578	636			
North Leg	Outbound	1,080	520			
<b>North Leg</b>	<b>TOTAL</b>	<b>1,658</b>	<b>1,156</b>	<b>8%</b>	<b>6%</b>	<b>20,888</b>
South Leg	Inbound	1,120	574			
South Leg	Outbound	580	583			
<b>South Leg</b>	<b>TOTAL</b>	<b>1,700</b>	<b>1,157</b>	<b>8%</b>	<b>6%</b>	<b>20,964</b>
East Leg	Inbound	0	0			
East Leg	Outbound	0	0			
<b>East Leg</b>	<b>TOTAL</b>	<b>0</b>	<b>0</b>	<b>#DIV/0!</b>	<b>#DIV/0!</b>	<b>-</b>
West Leg	Inbound	92	60			
West Leg	Outbound	130	167			
<b>West Leg</b>	<b>TOTAL</b>	<b>222</b>	<b>227</b>	<b>7%</b>	<b>7%</b>	<b>3,200</b>
<b>OVERALL TOTAL</b>		<b>3,580</b>	<b>2,540</b>	<b>8%</b>	<b>6%</b>	<b>45,051</b>

Z:\Shared\UcJobs\13030\Post Processing\[03\_Temescal Canyon & Lawson.xls]Output (3)

Project: Glen Ivy Senior Living  
 Scenario: Horizon Year (2040) Without Project

Job #: 13030  
 Analyst: CS  
 Date: 9/3/20

LOCATION: Temescal Canyon Rd. / Trilogy Pkwy.  
 FORECAST YEAR: 2040

INDIVIDUAL TURN VOLUME GROWTH REVIEW									
APPROACH	TURNING MOVEMENT	AM PEAK HOUR INPUT DATA				PM PEAK HOUR INPUT DATA			
		EXISTING COUNT	FUTURE VOLUME	DIFFERENCE	% CHANGE	EXISTING COUNT	FUTURE VOLUME	DIFFERENCE	% CHANGE
NORTH BOUND	Left	36	27	-9	-24%	37	38	1	3%
	Through	1,084	1,089	5	0%	304	433	129	42%
	Right	0	0	0	#DIV/0!	0	0	0	#DIV/0!
	<b>NB Total</b>	<b>1,120</b>	<b>1,116</b>	<b>-4</b>	<b>0%</b>	<b>341</b>	<b>471</b>	<b>130</b>	<b>38%</b>
SOUTH BOUND	Left	0	0	0	#DIV/0!	0	0	0	#DIV/0!
	Through	291	501	210	72%	484	490	6	1%
	Right	46	53	7	16%	79	82	3	3%
	<b>SB Total</b>	<b>336</b>	<b>554</b>	<b>218</b>	<b>65%</b>	<b>563</b>	<b>572</b>	<b>9</b>	<b>2%</b>
EAST BOUND	Left	36	31	-5	-13%	139	157	18	13%
	Through	0	0	0	#DIV/0!	0	0	0	#DIV/0!
	Right	18	19	1	3%	38	30	-8	-21%
	<b>EB Total</b>	<b>54</b>	<b>50</b>	<b>-4</b>	<b>-8%</b>	<b>177</b>	<b>187</b>	<b>10</b>	<b>6%</b>
WEST BOUND	Left	0	0	0	#DIV/0!	0	0	0	#DIV/0!
	Through	0	0	0	#DIV/0!	0	0	0	#DIV/0!
	Right	0	0	0	#DIV/0!	0	0	0	#DIV/0!
	<b>WB Total</b>	<b>0</b>	<b>0</b>	<b>0</b>	<b>#DIV/0!</b>	<b>0</b>	<b>0</b>	<b>0</b>	<b>#DIV/0!</b>
<b>TOTAL ENTERING VOLUME</b>		<b>1,510</b>	<b>1,720</b>	<b>209.7</b>	<b>14%</b>	<b>1,081</b>	<b>1,230</b>	<b>149</b>	<b>14%</b>

FORECAST PEAK HOUR TO ADT COMPARISON						
		VOLUMES		PERCENT OF ADT		ADT
		AM	PM	AM	PM	
North Leg	Inbound	554	572			
North Leg	Outbound	1,120	590			
<b>North Leg</b>	<b>TOTAL</b>	<b>1,674</b>	<b>1,162</b>	<b>8%</b>	<b>6%</b>	<b>20,096</b>
South Leg	Inbound	1,116	471			
South Leg	Outbound	520	520			
<b>South Leg</b>	<b>TOTAL</b>	<b>1,636</b>	<b>991</b>	<b>10%</b>	<b>6%</b>	<b>16,617</b>
East Leg	Inbound	0	0			
East Leg	Outbound	0	0			
<b>East Leg</b>	<b>TOTAL</b>	<b>0</b>	<b>0</b>	<b>#DIV/0!</b>	<b>#DIV/0!</b>	<b>-</b>
West Leg	Inbound	50	187			
West Leg	Outbound	80	120			
<b>West Leg</b>	<b>TOTAL</b>	<b>130</b>	<b>307</b>	<b>2%</b>	<b>6%</b>	<b>5,207</b>
<b>OVERALL TOTAL</b>		<b>3,440</b>	<b>2,460</b>	<b>8%</b>	<b>6%</b>	<b>41,919</b>

Z:\Shared\UcJobs\13030\Post Processing\[04\_Temescal Canyon & Trilogy Pkwy.xls]Output (3)

**APPENDIX 5.1:**

**EAP (2023 – RIRO AT DRIVEWAY 4) CONDITIONS INTERSECTION OPERATIONS  
ANALYSIS WORKSHEETS**

This Page Intentionally Left Blank



Intersection						
Int Delay, s/veh	0.8					
Movement	EBT	EBR	WBL	WBT	NBL	NBR
Lane Configurations	↑↑		↖	↑↑	↘	
Traffic Vol, veh/h	58	1	9	86	2	5
Future Vol, veh/h	58	1	9	86	2	5
Conflicting Peds, #/hr	0	0	0	0	0	0
Sign Control	Free	Free	Free	Free	Stop	Stop
RT Channelized	-	None	-	None	-	None
Storage Length	-	-	100	-	0	-
Veh in Median Storage, #	0	-	-	0	0	-
Grade, %	0	-	-	0	0	-
Peak Hour Factor	92	92	92	92	92	92
Heavy Vehicles, %	0	0	0	0	0	0
Mvmt Flow	63	1	10	93	2	5

Major/Minor	Major1	Major2	Minor1	Minor2	Minor3
Conflicting Flow All	0	0	64	0	131
Stage 1	-	-	-	-	64
Stage 2	-	-	-	-	67
Critical Hdwy	-	-	4.1	-	6.8
Critical Hdwy Stg 1	-	-	-	-	5.8
Critical Hdwy Stg 2	-	-	-	-	5.8
Follow-up Hdwy	-	-	2.2	-	3.5
Pot Cap-1 Maneuver	-	-	1551	-	855
Stage 1	-	-	-	-	957
Stage 2	-	-	-	-	954
Platoon blocked, %	-	-	-	-	-
Mov Cap-1 Maneuver	-	-	1551	-	850
Mov Cap-2 Maneuver	-	-	-	-	850
Stage 1	-	-	-	-	957
Stage 2	-	-	-	-	948

Approach	EB	WB	NB
HCM Control Delay, s	0	0.7	8.7
HCM LOS			A

Minor Lane/Major Mvmt	NBLn1	EBT	EBR	WBL	WBT
Capacity (veh/h)	978	-	-	1551	-
HCM Lane V/C Ratio	0.008	-	-	0.006	-
HCM Control Delay (s)	8.7	-	-	7.3	-
HCM Lane LOS	A	-	-	A	-
HCM 95th %tile Q(veh)	0	-	-	0	-

Intersection						
Int Delay, s/veh	0.5					
Movement	EBT	EBR	WBL	WBT	NBL	NBR
Lane Configurations	↑↑			↑↑		↑
Traffic Vol, veh/h	62	1	0	95	0	9
Future Vol, veh/h	62	1	0	95	0	9
Conflicting Peds, #/hr	0	0	0	0	0	0
Sign Control	Free	Free	Free	Free	Stop	Stop
RT Channelized	-	None	-	None	-	None
Storage Length	-	-	-	-	-	0
Veh in Median Storage, #	0	-	-	0	0	-
Grade, %	0	-	-	0	0	-
Peak Hour Factor	92	92	92	92	92	92
Heavy Vehicles, %	0	0	0	0	0	0
Mvmt Flow	67	1	0	103	0	10

Major/Minor	Major1	Major2	Minor1
Conflicting Flow All	0	0	- - - 34
Stage 1	-	-	- - -
Stage 2	-	-	- - -
Critical Hdwy	-	-	- - - 6.9
Critical Hdwy Stg 1	-	-	- - -
Critical Hdwy Stg 2	-	-	- - -
Follow-up Hdwy	-	-	- - - 3.3
Pot Cap-1 Maneuver	-	- 0	- 0 1038
Stage 1	-	- 0	- 0 -
Stage 2	-	- 0	- 0 -
Platoon blocked, %	-	-	-
Mov Cap-1 Maneuver	-	-	- - 1038
Mov Cap-2 Maneuver	-	-	- - -
Stage 1	-	-	- - -
Stage 2	-	-	- - -

Approach	EB	WB	NB
HCM Control Delay, s	0	0	8.5
HCM LOS			A

Minor Lane/Major Mvmt	NBLn1	EBT	EBR	WBT
Capacity (veh/h)	1038	-	-	-
HCM Lane V/C Ratio	0.009	-	-	-
HCM Control Delay (s)	8.5	-	-	-
HCM Lane LOS	A	-	-	-
HCM 95th %tile Q(veh)	0	-	-	-

Intersection						
Int Delay, s/veh	1.9					
Movement	EBL	EBR	NBL	NBT	SBT	SBR
Lane Configurations	Y		Y	↑	↑	
Traffic Vol, veh/h	59	10	102	1100	363	35
Future Vol, veh/h	59	10	102	1100	363	35
Conflicting Peds, #/hr	0	0	0	0	0	0
Sign Control	Stop	Stop	Free	Free	Free	Free
RT Channelized	-	None	-	None	-	None
Storage Length	0	-	200	-	-	-
Veh in Median Storage, #	2	-	-	0	0	-
Grade, %	0	-	-	0	0	-
Peak Hour Factor	86	86	86	86	86	86
Heavy Vehicles, %	0	0	0	0	0	0
Mvmt Flow	69	12	119	1279	422	41

Major/Minor	Minor2	Major1		Major2	
Conflicting Flow All	1960	443	463	0	0
Stage 1	443	-	-	-	-
Stage 2	1517	-	-	-	-
Critical Hdwy	6.4	6.2	4.1	-	-
Critical Hdwy Stg 1	5.4	-	-	-	-
Critical Hdwy Stg 2	5.4	-	-	-	-
Follow-up Hdwy	3.5	3.3	2.2	-	-
Pot Cap-1 Maneuver	71	619	1109	-	-
Stage 1	651	-	-	-	-
Stage 2	202	-	-	-	-
Platoon blocked, %				-	-
Mov Cap-1 Maneuver	~ 63	619	1109	-	-
Mov Cap-2 Maneuver	185	-	-	-	-
Stage 1	581	-	-	-	-
Stage 2	202	-	-	-	-

Approach	EB	NB	SB
HCM Control Delay, s	33.2	0.7	0
HCM LOS	D		

Minor Lane/Major Mvmt	NBL	NBT	EBLn1	SBT	SBR
Capacity (veh/h)	1109	-	206	-	-
HCM Lane V/C Ratio	0.107	-	0.389	-	-
HCM Control Delay (s)	8.6	-	33.2	-	-
HCM Lane LOS	A	-	D	-	-
HCM 95th %tile Q(veh)	0.4	-	1.7	-	-

Notes  
 ~: Volume exceeds capacity    \$: Delay exceeds 300s    +: Computation Not Defined    \*: All major volume in platoon

Timings  
4: Temescal Canyon Rd & Trilogy Pkwy



Lane Group	EBL	EBR	NBL	NBT	SBT	SBR
Lane Configurations	↖	↗	↖	↑	↑	↗
Traffic Volume (vph)	52	20	44	1151	322	51
Future Volume (vph)	52	20	44	1151	322	51
Turn Type	Prot	Perm	Prot	NA	NA	Perm
Protected Phases	4		5	2	6	
Permitted Phases		4				6
Detector Phase	4	4	5	2	6	6
Switch Phase						
Minimum Initial (s)	10.0	10.0	5.0	10.0	10.0	10.0
Minimum Split (s)	28.8	28.8	9.6	15.4	33.4	33.4
Total Split (s)	28.8	28.8	10.0	61.2	51.2	51.2
Total Split (%)	32.0%	32.0%	11.1%	68.0%	56.9%	56.9%
Yellow Time (s)	4.8	4.8	3.6	4.4	4.4	4.4
All-Red Time (s)	1.0	1.0	1.0	1.0	1.0	1.0
Lost Time Adjust (s)	-1.8	-1.8	-0.6	-1.4	-1.4	-1.4
Total Lost Time (s)	4.0	4.0	4.0	4.0	4.0	4.0
Lead/Lag			Lead		Lag	Lag
Lead-Lag Optimize?			Yes		Yes	Yes
Recall Mode	None	None	None	None	None	None
Act Effct Green (s)	15.4	15.4	6.7	52.8	48.1	48.1
Actuated g/C Ratio	0.24	0.24	0.10	0.82	0.75	0.75
v/c Ratio	0.12	0.05	0.24	0.75	0.23	0.04
Control Delay	26.5	12.0	39.2	12.6	7.9	3.0
Queue Delay	0.0	0.0	0.0	0.0	0.0	0.0
Total Delay	26.5	12.0	39.2	12.6	7.9	3.0
LOS	C	B	D	B	A	A
Approach Delay	22.6			13.6	7.2	
Approach LOS	C			B	A	

Intersection Summary

Cycle Length: 90  
 Actuated Cycle Length: 64.1  
 Natural Cycle: 90  
 Control Type: Actuated-Uncoordinated  
 Maximum v/c Ratio: 0.75  
 Intersection Signal Delay: 12.5  
 Intersection LOS: B  
 Intersection Capacity Utilization 75.6%  
 ICU Level of Service D  
 Analysis Period (min) 15

Splits and Phases: 4: Temescal Canyon Rd & Trilogy Pkwy

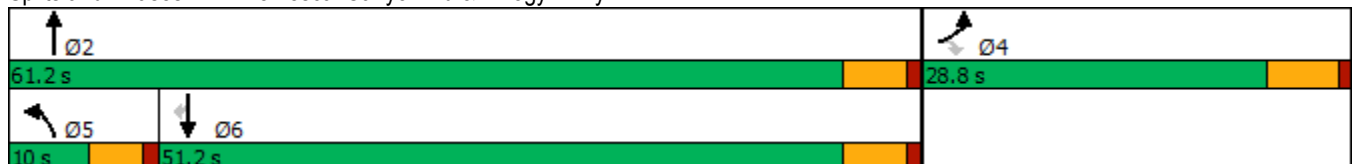



HCM 6th Signalized Intersection Summary  
4: Temescal Canyon Rd & Trilogy Pkwy

Glen Ivy Senior Living (JN 13030)  
09/11/2020



Movement	EBL	EBR	NBL	NBT	SBT	SBR
Lane Configurations						
Traffic Volume (veh/h)	52	20	44	1151	322	51
Future Volume (veh/h)	52	20	44	1151	322	51
Initial Q (Qb), veh	0	0	0	0	0	0
Ped-Bike Adj(A_pbT)	1.00	1.00	1.00			1.00
Parking Bus, Adj	1.00	1.00	1.00	1.00	1.00	1.00
Work Zone On Approach	No			No	No	
Adj Sat Flow, veh/h/ln	1900	1900	1900	1900	1900	1900
Adj Flow Rate, veh/h	53	8	45	1174	329	50
Peak Hour Factor	0.98	0.98	0.98	0.98	0.98	0.98
Percent Heavy Veh, %	0	0	0	0	0	0
Cap, veh/h	253	225	100	1369	1132	959
Arrive On Green	0.14	0.14	0.06	0.72	0.60	0.60
Sat Flow, veh/h	1810	1610	1810	1900	1900	1610
Grp Volume(v), veh/h	53	8	45	1174	329	50
Grp Sat Flow(s),veh/h/ln	1810	1610	1810	1900	1900	1610
Q Serve(g_s), s	1.5	0.2	1.4	25.9	4.9	0.7
Cycle Q Clear(g_c), s	1.5	0.2	1.4	25.9	4.9	0.7
Prop In Lane	1.00	1.00	1.00			1.00
Lane Grp Cap(c), veh/h	253	225	100	1369	1132	959
V/C Ratio(X)	0.21	0.04	0.45	0.86	0.29	0.05
Avail Cap(c_a), veh/h	783	697	189	1896	1565	1326
HCM Platoon Ratio	1.00	1.00	1.00	1.00	1.00	1.00
Upstream Filter(I)	1.00	1.00	1.00	1.00	1.00	1.00
Uniform Delay (d), s/veh	21.8	21.3	26.2	5.9	5.7	4.8
Incr Delay (d2), s/veh	0.4	0.1	1.2	3.0	0.1	0.0
Initial Q Delay(d3),s/veh	0.0	0.0	0.0	0.0	0.0	0.0
%ile BackOfQ(50%),veh/ln	0.6	0.0	0.6	4.6	1.3	0.2
Unsig. Movement Delay, s/veh						
LnGrp Delay(d),s/veh	22.3	21.4	27.4	8.9	5.8	4.9
LnGrp LOS	C	C	C	A	A	A
Approach Vol, veh/h	61			1219	379	
Approach Delay, s/veh	22.1			9.6	5.7	
Approach LOS	C			A	A	
Timer - Assigned Phs		2		4	5	6
Phs Duration (G+Y+Rc), s		45.3		12.0	7.2	38.1
Change Period (Y+Rc), s		5.4		5.8	4.6	5.4
Max Green Setting (Gmax), s		55.8		23.0	5.4	45.8
Max Q Clear Time (g_c+I1), s		27.9		3.5	3.4	6.9
Green Ext Time (p_c), s		12.0		0.1	0.0	2.1
<b>Intersection Summary</b>						
HCM 6th Ctrl Delay			9.2			
HCM 6th LOS			A			

Intersection						
Int Delay, s/veh	0					
Movement	EBL	EBR	NBL	NBT	SBT	SBR
Lane Configurations		↗		↑	↘	
Traffic Vol, veh/h	0	1	0	1195	333	10
Future Vol, veh/h	0	1	0	1195	333	10
Conflicting Peds, #/hr	0	0	0	0	0	0
Sign Control	Stop	Stop	Free	Free	Free	Free
RT Channelized	-	None	-	None	-	None
Storage Length	-	0	-	-	-	-
Veh in Median Storage, #	0	-	-	0	0	-
Grade, %	0	-	-	0	0	-
Peak Hour Factor	92	92	92	92	92	92
Heavy Vehicles, %	0	0	0	0	0	0
Mvmt Flow	0	1	0	1299	362	11

Major/Minor	Minor2	Major1	Major2		
Conflicting Flow All	-	368	-	0	-
Stage 1	-	-	-	-	-
Stage 2	-	-	-	-	-
Critical Hdwy	-	6.2	-	-	-
Critical Hdwy Stg 1	-	-	-	-	-
Critical Hdwy Stg 2	-	-	-	-	-
Follow-up Hdwy	-	3.3	-	-	-
Pot Cap-1 Maneuver	0	682	0	-	-
Stage 1	0	-	0	-	-
Stage 2	0	-	0	-	-
Platoon blocked, %				-	-
Mov Cap-1 Maneuver	-	682	-	-	-
Mov Cap-2 Maneuver	-	-	-	-	-
Stage 1	-	-	-	-	-
Stage 2	-	-	-	-	-

Approach	EB	NB	SB
HCM Control Delay, s	10.3	0	0
HCM LOS	B		

Minor Lane/Major Mvmt	NBT	EBLn1	SBT	SBR
Capacity (veh/h)	-	682	-	-
HCM Lane V/C Ratio	-	0.002	-	-
HCM Control Delay (s)	-	10.3	-	-
HCM Lane LOS	-	B	-	-
HCM 95th %tile Q(veh)	-	0	-	-

Intersection						
Int Delay, s/veh	0					
Movement	EBL	EBR	NBL	NBT	SBT	SBR
Lane Configurations		↗		↑	↘	
Traffic Vol, veh/h	0	3	0	1195	331	4
Future Vol, veh/h	0	3	0	1195	331	4
Conflicting Peds, #/hr	0	0	0	0	0	0
Sign Control	Stop	Stop	Free	Free	Free	Free
RT Channelized	-	None	-	None	-	None
Storage Length	-	0	-	-	-	-
Veh in Median Storage, #	0	-	-	0	0	-
Grade, %	0	-	-	0	0	-
Peak Hour Factor	92	92	92	92	92	92
Heavy Vehicles, %	0	0	0	0	0	0
Mvmt Flow	0	3	0	1299	360	4

Major/Minor	Minor2	Major1	Major2		
Conflicting Flow All	-	362	-	0	-
Stage 1	-	-	-	-	-
Stage 2	-	-	-	-	-
Critical Hdwy	-	6.2	-	-	-
Critical Hdwy Stg 1	-	-	-	-	-
Critical Hdwy Stg 2	-	-	-	-	-
Follow-up Hdwy	-	3.3	-	-	-
Pot Cap-1 Maneuver	0	687	0	-	-
Stage 1	0	-	0	-	-
Stage 2	0	-	0	-	-
Platoon blocked, %				-	-
Mov Cap-1 Maneuver	-	687	-	-	-
Mov Cap-2 Maneuver	-	-	-	-	-
Stage 1	-	-	-	-	-
Stage 2	-	-	-	-	-

Approach	EB	NB	SB
HCM Control Delay, s	10.3	0	0
HCM LOS	B		

Minor Lane/Major Mvmt	NBT EBLn1	SBT	SBR
Capacity (veh/h)	- 687	-	-
HCM Lane V/C Ratio	- 0.005	-	-
HCM Control Delay (s)	- 10.3	-	-
HCM Lane LOS	- B	-	-
HCM 95th %tile Q(veh)	- 0	-	-

Intersection						
Int Delay, s/veh	0.6					
Movement	EBT	EBR	WBL	WBT	NBL	NBR
Lane Configurations	↑↑		↘	↑↑	↘	
Traffic Vol, veh/h	189	1	9	123	4	9
Future Vol, veh/h	189	1	9	123	4	9
Conflicting Peds, #/hr	0	0	0	0	0	0
Sign Control	Free	Free	Free	Free	Stop	Stop
RT Channelized	-	None	-	None	-	None
Storage Length	-	-	100	-	0	-
Veh in Median Storage, #	0	-	-	0	0	-
Grade, %	0	-	-	0	0	-
Peak Hour Factor	92	92	92	92	92	92
Heavy Vehicles, %	0	0	0	0	0	0
Mvmt Flow	205	1	10	134	4	10

Major/Minor	Major1	Major2	Minor1	Minor2	Minor3
Conflicting Flow All	0	0	206	0	293
Stage 1	-	-	-	-	206
Stage 2	-	-	-	-	87
Critical Hdwy	-	-	4.1	-	6.8
Critical Hdwy Stg 1	-	-	-	-	5.8
Critical Hdwy Stg 2	-	-	-	-	5.8
Follow-up Hdwy	-	-	2.2	-	3.5
Pot Cap-1 Maneuver	-	-	1377	-	680
Stage 1	-	-	-	-	814
Stage 2	-	-	-	-	932
Platoon blocked, %	-	-	-	-	-
Mov Cap-1 Maneuver	-	-	1377	-	675
Mov Cap-2 Maneuver	-	-	-	-	675
Stage 1	-	-	-	-	814
Stage 2	-	-	-	-	925

Approach	EB	WB	NB
HCM Control Delay, s	0	0.5	9.4
HCM LOS			A

Minor Lane/Major Mvmt	NBLn1	EBT	EBR	WBL	WBT
Capacity (veh/h)	838	-	-	1377	-
HCM Lane V/C Ratio	0.017	-	-	0.007	-
HCM Control Delay (s)	9.4	-	-	7.6	-
HCM Lane LOS	A	-	-	A	-
HCM 95th %tile Q(veh)	0.1	-	-	0	-



Intersection						
Int Delay, s/veh	0.4					
Movement	EBT	EBR	WBL	WBT	NBL	NBR
Lane Configurations	↑↑			↑↑		↑
Traffic Vol, veh/h	197	1	0	132	0	16
Future Vol, veh/h	197	1	0	132	0	16
Conflicting Peds, #/hr	0	0	0	0	0	0
Sign Control	Free	Free	Free	Free	Stop	Stop
RT Channelized	-	None	-	None	-	None
Storage Length	-	-	-	-	-	0
Veh in Median Storage, #	0	-	-	0	0	-
Grade, %	0	-	-	0	0	-
Peak Hour Factor	92	92	92	92	92	92
Heavy Vehicles, %	0	0	0	0	0	0
Mvmt Flow	214	1	0	143	0	17

Major/Minor	Major1	Major2	Minor1		
Conflicting Flow All	0	0	-	-	108
Stage 1	-	-	-	-	-
Stage 2	-	-	-	-	-
Critical Hdwy	-	-	-	-	6.9
Critical Hdwy Stg 1	-	-	-	-	-
Critical Hdwy Stg 2	-	-	-	-	-
Follow-up Hdwy	-	-	-	-	3.3
Pot Cap-1 Maneuver	-	-	0	-	932
Stage 1	-	-	0	-	-
Stage 2	-	-	0	-	-
Platoon blocked, %	-	-	-	-	-
Mov Cap-1 Maneuver	-	-	-	-	932
Mov Cap-2 Maneuver	-	-	-	-	-
Stage 1	-	-	-	-	-
Stage 2	-	-	-	-	-

Approach	EB	WB	NB
HCM Control Delay, s	0	0	8.9
HCM LOS			A

Minor Lane/Major Mvmt	NBLn1	EBT	EBR	WBT
Capacity (veh/h)	932	-	-	-
HCM Lane V/C Ratio	0.019	-	-	-
HCM Control Delay (s)	8.9	-	-	-
HCM Lane LOS	A	-	-	-
HCM 95th %tile Q(veh)	0.1	-	-	-

Intersection						
Int Delay, s/veh	1					
Movement	EBL	EBR	NBL	NBT	SBT	SBR
Lane Configurations	↔		↔	↑	↑	
Traffic Vol, veh/h	40	22	29	465	593	78
Future Vol, veh/h	40	22	29	465	593	78
Conflicting Peds, #/hr	0	0	0	0	0	0
Sign Control	Stop	Stop	Free	Free	Free	Free
RT Channelized	-	None	-	None	-	None
Storage Length	0	-	200	-	-	-
Veh in Median Storage, #	2	-	-	0	0	-
Grade, %	0	-	-	0	0	-
Peak Hour Factor	94	94	94	94	94	94
Heavy Vehicles, %	0	0	0	0	0	0
Mvmt Flow	43	23	31	495	631	83

Major/Minor	Minor2	Major1	Major2			
Conflicting Flow All	1230	673	714	0	-	0
Stage 1	673	-	-	-	-	-
Stage 2	557	-	-	-	-	-
Critical Hdwy	6.4	6.2	4.1	-	-	-
Critical Hdwy Stg 1	5.4	-	-	-	-	-
Critical Hdwy Stg 2	5.4	-	-	-	-	-
Follow-up Hdwy	3.5	3.3	2.2	-	-	-
Pot Cap-1 Maneuver	198	459	895	-	-	-
Stage 1	511	-	-	-	-	-
Stage 2	578	-	-	-	-	-
Platoon blocked, %				-	-	-
Mov Cap-1 Maneuver	191	459	895	-	-	-
Mov Cap-2 Maneuver	395	-	-	-	-	-
Stage 1	493	-	-	-	-	-
Stage 2	578	-	-	-	-	-

Approach	EB	NB	SB
HCM Control Delay, s	15.3	0.5	0
HCM LOS	C		

Minor Lane/Major Mvmt	NBL	NBT	EBLn1	SBT	SBR
Capacity (veh/h)	895	-	416	-	-
HCM Lane V/C Ratio	0.034	-	0.159	-	-
HCM Control Delay (s)	9.2	-	15.3	-	-
HCM Lane LOS	A	-	C	-	-
HCM 95th %tile Q(veh)	0.1	-	0.6	-	-

Timings  
4: Temescal Canyon Rd & Trilogy Pkwy



Lane Group	EBL	EBR	NBL	NBT	SBT	SBR
Lane Configurations	↖	↗	↖	↑	↑	↗
Traffic Volume (vph)	171	42	46	323	528	87
Future Volume (vph)	171	42	46	323	528	87
Turn Type	Prot	Perm	Prot	NA	NA	Perm
Protected Phases	4		5	2	6	
Permitted Phases		4				6
Detector Phase	4	4	5	2	6	6
Switch Phase						
Minimum Initial (s)	10.0	10.0	5.0	10.0	10.0	10.0
Minimum Split (s)	28.8	28.8	9.6	15.4	33.4	33.4
Total Split (s)	31.0	31.0	11.0	59.0	48.0	48.0
Total Split (%)	34.4%	34.4%	12.2%	65.6%	53.3%	53.3%
Yellow Time (s)	4.8	4.8	3.6	4.4	4.4	4.4
All-Red Time (s)	1.0	1.0	1.0	1.0	1.0	1.0
Lost Time Adjust (s)	-1.8	-1.8	-0.6	-1.4	-1.4	-1.4
Total Lost Time (s)	4.0	4.0	4.0	4.0	4.0	4.0
Lead/Lag			Lead		Lag	Lag
Lead-Lag Optimize?			Yes		Yes	Yes
Recall Mode	None	None	None	None	None	None
Act Effct Green (s)	18.5	18.5	8.3	33.5	28.4	28.4
Actuated g/C Ratio	0.36	0.36	0.16	0.66	0.56	0.56
v/c Ratio	0.27	0.07	0.16	0.27	0.52	0.10
Control Delay	20.4	7.7	30.6	6.6	14.4	4.8
Queue Delay	0.0	0.0	0.0	0.0	0.0	0.0
Total Delay	20.4	7.7	30.6	6.6	14.4	4.8
LOS	C	A	C	A	B	A
Approach Delay	17.9			9.6	13.0	
Approach LOS	B			A	B	

Intersection Summary

Cycle Length: 90	
Actuated Cycle Length: 50.7	
Natural Cycle: 75	
Control Type: Actuated-Uncoordinated	
Maximum v/c Ratio: 0.52	
Intersection Signal Delay: 12.8	Intersection LOS: B
Intersection Capacity Utilization 51.4%	ICU Level of Service A
Analysis Period (min) 15	

Splits and Phases: 4: Temescal Canyon Rd & Trilogy Pkwy



HCM 6th Signalized Intersection Summary  
4: Temescal Canyon Rd & Trilogy Pkwy

Glen Ivy Senior Living (JN 13030)  
09/11/2020



Movement	EBL	EBR	NBL	NBT	SBT	SBR
Lane Configurations						
Traffic Volume (veh/h)	171	42	46	323	528	87
Future Volume (veh/h)	171	42	46	323	528	87
Initial Q (Qb), veh	0	0	0	0	0	0
Ped-Bike Adj(A_pbT)	1.00	1.00	1.00			0.98
Parking Bus, Adj	1.00	1.00	1.00	1.00	1.00	1.00
Work Zone On Approach	No			No	No	
Adj Sat Flow, veh/h/ln	1900	1900	1900	1900	1900	1900
Adj Flow Rate, veh/h	178	28	48	336	550	79
Peak Hour Factor	0.96	0.96	0.96	0.96	0.96	0.96
Percent Heavy Veh, %	0	0	0	0	0	0
Cap, veh/h	456	406	116	1072	775	643
Arrive On Green	0.25	0.25	0.06	0.56	0.41	0.41
Sat Flow, veh/h	1810	1610	1810	1900	1900	1577
Grp Volume(v), veh/h	178	28	48	336	550	79
Grp Sat Flow(s),veh/h/ln	1810	1610	1810	1900	1900	1577
Q Serve(g_s), s	3.6	0.6	1.1	4.1	10.5	1.4
Cycle Q Clear(g_c), s	3.6	0.6	1.1	4.1	10.5	1.4
Prop In Lane	1.00	1.00	1.00			1.00
Lane Grp Cap(c), veh/h	456	406	116	1072	775	643
V/C Ratio(X)	0.39	0.07	0.41	0.31	0.71	0.12
Avail Cap(c_a), veh/h	1123	999	291	2401	1921	1594
HCM Platoon Ratio	1.00	1.00	1.00	1.00	1.00	1.00
Upstream Filter(I)	1.00	1.00	1.00	1.00	1.00	1.00
Uniform Delay (d), s/veh	13.5	12.4	19.6	5.0	10.7	8.0
Incr Delay (d2), s/veh	0.5	0.1	0.9	0.2	1.2	0.1
Initial Q Delay(d3),s/veh	0.0	0.0	0.0	0.0	0.0	0.0
%ile BackOfQ(50%),veh/ln	1.1	0.0	0.4	0.8	3.2	0.3
Unsig. Movement Delay, s/veh						
LnGrp Delay(d),s/veh	14.0	12.5	20.4	5.2	12.0	8.1
LnGrp LOS	B	B	C	A	B	A
Approach Vol, veh/h	206			384	629	
Approach Delay, s/veh	13.8			7.1	11.5	
Approach LOS	B			A	B	
Timer - Assigned Phs		2		4	5	6
Phs Duration (G+Y+Rc), s		28.6		15.0	6.8	21.8
Change Period (Y+Rc), s		5.4		5.8	4.6	5.4
Max Green Setting (Gmax), s		53.6		25.2	6.4	42.6
Max Q Clear Time (g_c+11), s		6.1		5.6	3.1	12.5
Green Ext Time (p_c), s		2.0		0.5	0.0	3.9
<b>Intersection Summary</b>						
HCM 6th Ctrl Delay			10.5			
HCM 6th LOS			B			



Intersection						
Int Delay, s/veh	0					
Movement	EBL	EBR	NBL	NBT	SBT	SBR
Lane Configurations		↗		↑	↘	
Traffic Vol, veh/h	0	3	0	369	559	11
Future Vol, veh/h	0	3	0	369	559	11
Conflicting Peds, #/hr	0	0	0	0	0	0
Sign Control	Stop	Stop	Free	Free	Free	Free
RT Channelized	-	None	-	None	-	None
Storage Length	-	0	-	-	-	-
Veh in Median Storage, #	0	-	-	0	0	-
Grade, %	0	-	-	0	0	-
Peak Hour Factor	92	92	92	92	92	92
Heavy Vehicles, %	0	0	0	0	0	0
Mvmt Flow	0	3	0	401	608	12

Major/Minor	Minor2	Major1	Major2		
Conflicting Flow All	-	614	-	0	-
Stage 1	-	-	-	-	-
Stage 2	-	-	-	-	-
Critical Hdwy	-	6.2	-	-	-
Critical Hdwy Stg 1	-	-	-	-	-
Critical Hdwy Stg 2	-	-	-	-	-
Follow-up Hdwy	-	3.3	-	-	-
Pot Cap-1 Maneuver	0	496	0	-	-
Stage 1	0	-	0	-	-
Stage 2	0	-	0	-	-
Platoon blocked, %				-	-
Mov Cap-1 Maneuver	-	496	-	-	-
Mov Cap-2 Maneuver	-	-	-	-	-
Stage 1	-	-	-	-	-
Stage 2	-	-	-	-	-

Approach	EB	NB	SB
HCM Control Delay, s	12.3	0	0
HCM LOS	B		

Minor Lane/Major Mvmt	NBT EBLn1	SBT	SBR
Capacity (veh/h)	- 496	-	-
HCM Lane V/C Ratio	- 0.007	-	-
HCM Control Delay (s)	- 12.3	-	-
HCM Lane LOS	- B	-	-
HCM 95th %tile Q(veh)	- 0	-	-

Intersection						
Int Delay, s/veh	0.1					
Movement	EBL	EBR	NBL	NBT	SBT	SBR
Lane Configurations		↗		↑	↘	
Traffic Vol, veh/h	0	5	0	369	557	4
Future Vol, veh/h	0	5	0	369	557	4
Conflicting Peds, #/hr	0	0	0	0	0	0
Sign Control	Stop	Stop	Free	Free	Free	Free
RT Channelized	-	None	-	None	-	None
Storage Length	-	0	-	-	-	-
Veh in Median Storage, #	0	-	-	0	0	-
Grade, %	0	-	-	0	0	-
Peak Hour Factor	92	92	92	92	92	92
Heavy Vehicles, %	0	0	0	0	0	0
Mvmt Flow	0	5	0	401	605	4

Major/Minor	Minor2	Major1	Major2		
Conflicting Flow All	-	607	-	0	0
Stage 1	-	-	-	-	-
Stage 2	-	-	-	-	-
Critical Hdwy	-	6.2	-	-	-
Critical Hdwy Stg 1	-	-	-	-	-
Critical Hdwy Stg 2	-	-	-	-	-
Follow-up Hdwy	-	3.3	-	-	-
Pot Cap-1 Maneuver	0	500	0	-	-
Stage 1	0	-	0	-	-
Stage 2	0	-	0	-	-
Platoon blocked, %				-	-
Mov Cap-1 Maneuver	-	500	-	-	-
Mov Cap-2 Maneuver	-	-	-	-	-
Stage 1	-	-	-	-	-
Stage 2	-	-	-	-	-

Approach	EB	NB	SB
HCM Control Delay, s	12.3	0	0
HCM LOS	B		

Minor Lane/Major Mvmt	NBT	EBLn1	SBT	SBR
Capacity (veh/h)	-	500	-	-
HCM Lane V/C Ratio	-	0.011	-	-
HCM Control Delay (s)	-	12.3	-	-
HCM Lane LOS	-	B	-	-
HCM 95th %tile Q(veh)	-	0	-	-

**APPENDIX 5.2:**

**EAP (2023 – FULL ACCESS AT DRIVEWAY 4) CONDITIONS INTERSECTION  
OPERATIONS ANALYSIS WORKSHEETS**

This Page Intentionally Left Blank



Intersection						
Int Delay, s/veh	0.5					
Movement	EBT	EBR	WBL	WBT	NBL	NBR
Lane Configurations	↑↑		↑	↑↑	↑	
Traffic Vol, veh/h	58	1	5	86	2	3
Future Vol, veh/h	58	1	5	86	2	3
Conflicting Peds, #/hr	0	0	0	0	0	0
Sign Control	Free	Free	Free	Free	Stop	Stop
RT Channelized	-	None	-	None	-	None
Storage Length	-	-	100	-	0	-
Veh in Median Storage, #	0	-	-	0	0	-
Grade, %	0	-	-	0	0	-
Peak Hour Factor	92	92	92	92	92	92
Heavy Vehicles, %	0	0	0	0	0	0
Mvmt Flow	63	1	5	93	2	3

Major/Minor	Major1	Major2	Minor1	Minor2	Minor3
Conflicting Flow All	0	0	64	0	121
Stage 1	-	-	-	-	64
Stage 2	-	-	-	-	57
Critical Hdwy	-	-	4.1	-	6.8
Critical Hdwy Stg 1	-	-	-	-	5.8
Critical Hdwy Stg 2	-	-	-	-	5.8
Follow-up Hdwy	-	-	2.2	-	3.5
Pot Cap-1 Maneuver	-	-	1551	-	867
Stage 1	-	-	-	-	957
Stage 2	-	-	-	-	965
Platoon blocked, %	-	-	-	-	-
Mov Cap-1 Maneuver	-	-	1551	-	864
Mov Cap-2 Maneuver	-	-	-	-	864
Stage 1	-	-	-	-	957
Stage 2	-	-	-	-	962

Approach	EB	WB	NB
HCM Control Delay, s	0	0.4	8.8
HCM LOS			A

Minor Lane/Major Mvmt	NBLn1	EBT	EBR	WBL	WBT
Capacity (veh/h)	962	-	-	1551	-
HCM Lane V/C Ratio	0.006	-	-	0.004	-
HCM Control Delay (s)	8.8	-	-	7.3	-
HCM Lane LOS	A	-	-	A	-
HCM 95th %tile Q(veh)	0	-	-	0	-

Intersection						
Int Delay, s/veh	0.4					
Movement	EBT	EBR	WBL	WBT	NBL	NBR
Lane Configurations	↑↑			↑↑		↑
Traffic Vol, veh/h	60	1	0	91	0	7
Future Vol, veh/h	60	1	0	91	0	7
Conflicting Peds, #/hr	0	0	0	0	0	0
Sign Control	Free	Free	Free	Free	Stop	Stop
RT Channelized	-	None	-	None	-	None
Storage Length	-	-	-	-	-	0
Veh in Median Storage, #	0	-	-	0	0	-
Grade, %	0	-	-	0	0	-
Peak Hour Factor	92	92	92	92	92	92
Heavy Vehicles, %	0	0	0	0	0	0
Mvmt Flow	65	1	0	99	0	8

Major/Minor	Major1	Major2	Minor1
Conflicting Flow All	0	0	- - - 33
Stage 1	-	-	- - -
Stage 2	-	-	- - -
Critical Hdwy	-	-	- - - 6.9
Critical Hdwy Stg 1	-	-	- - -
Critical Hdwy Stg 2	-	-	- - -
Follow-up Hdwy	-	-	- - - 3.3
Pot Cap-1 Maneuver	-	- 0	- 0 1040
Stage 1	-	- 0	- 0 -
Stage 2	-	- 0	- 0 -
Platoon blocked, %	-	-	-
Mov Cap-1 Maneuver	-	-	- - 1040
Mov Cap-2 Maneuver	-	-	- - -
Stage 1	-	-	- - -
Stage 2	-	-	- - -

Approach	EB	WB	NB
HCM Control Delay, s	0	0	8.5
HCM LOS			A

Minor Lane/Major Mvmt	NBLn1	EBT	EBR	WBT
Capacity (veh/h)	1040	-	-	-
HCM Lane V/C Ratio	0.007	-	-	-
HCM Control Delay (s)	8.5	-	-	-
HCM Lane LOS	A	-	-	-
HCM 95th %tile Q(veh)	0	-	-	-

Intersection						
Int Delay, s/veh	1.9					
Movement	EBL	EBR	NBL	NBT	SBT	SBR
Lane Configurations	↔		↔	↑	↑	
Traffic Vol, veh/h	59	10	102	1100	363	35
Future Vol, veh/h	59	10	102	1100	363	35
Conflicting Peds, #/hr	0	0	0	0	0	0
Sign Control	Stop	Stop	Free	Free	Free	Free
RT Channelized	-	None	-	None	-	None
Storage Length	0	-	200	-	-	-
Veh in Median Storage, #	2	-	-	0	0	-
Grade, %	0	-	-	0	0	-
Peak Hour Factor	86	86	86	86	86	86
Heavy Vehicles, %	0	0	0	0	0	0
Mvmt Flow	69	12	119	1279	422	41

Major/Minor	Minor2	Major1		Major2	
Conflicting Flow All	1960	443	463	0	0
Stage 1	443	-	-	-	-
Stage 2	1517	-	-	-	-
Critical Hdwy	6.4	6.2	4.1	-	-
Critical Hdwy Stg 1	5.4	-	-	-	-
Critical Hdwy Stg 2	5.4	-	-	-	-
Follow-up Hdwy	3.5	3.3	2.2	-	-
Pot Cap-1 Maneuver	71	619	1109	-	-
Stage 1	651	-	-	-	-
Stage 2	202	-	-	-	-
Platoon blocked, %				-	-
Mov Cap-1 Maneuver	~ 63	619	1109	-	-
Mov Cap-2 Maneuver	185	-	-	-	-
Stage 1	581	-	-	-	-
Stage 2	202	-	-	-	-

Approach	EB	NB	SB
HCM Control Delay, s	33.2	0.7	0
HCM LOS	D		

Minor Lane/Major Mvmt	NBL	NBT	EBLn1	SBT	SBR
Capacity (veh/h)	1109	-	206	-	-
HCM Lane V/C Ratio	0.107	-	0.389	-	-
HCM Control Delay (s)	8.6	-	33.2	-	-
HCM Lane LOS	A	-	D	-	-
HCM 95th %tile Q(veh)	0.4	-	1.7	-	-

Notes  
 ~: Volume exceeds capacity    \$: Delay exceeds 300s    +: Computation Not Defined    \*: All major volume in platoon

Timings  
4: Temescal Canyon Rd & Trilogy Pkwy



Lane Group	EBL	EBR	NBL	NBT	SBT	SBR
Lane Configurations	↖	↗	↖	↑	↑	↗
Traffic Volume (vph)	47	20	41	1156	322	51
Future Volume (vph)	47	20	41	1156	322	51
Turn Type	Prot	Perm	Prot	NA	NA	Perm
Protected Phases	4		5	2	6	
Permitted Phases		4				6
Detector Phase	4	4	5	2	6	6
Switch Phase						
Minimum Initial (s)	10.0	10.0	5.0	10.0	10.0	10.0
Minimum Split (s)	28.8	28.8	9.6	15.4	33.4	33.4
Total Split (s)	28.8	28.8	10.0	61.2	51.2	51.2
Total Split (%)	32.0%	32.0%	11.1%	68.0%	56.9%	56.9%
Yellow Time (s)	4.8	4.8	3.6	4.4	4.4	4.4
All-Red Time (s)	1.0	1.0	1.0	1.0	1.0	1.0
Lost Time Adjust (s)	-1.8	-1.8	-0.6	-1.4	-1.4	-1.4
Total Lost Time (s)	4.0	4.0	4.0	4.0	4.0	4.0
Lead/Lag			Lead		Lag	Lag
Lead-Lag Optimize?			Yes		Yes	Yes
Recall Mode	None	None	None	None	None	None
Act Effct Green (s)	15.2	15.2	6.6	53.5	48.7	48.7
Actuated g/C Ratio	0.23	0.23	0.10	0.82	0.75	0.75
v/c Ratio	0.11	0.05	0.23	0.75	0.23	0.04
Control Delay	26.5	12.0	39.2	12.7	7.9	3.0
Queue Delay	0.0	0.0	0.0	0.0	0.0	0.0
Total Delay	26.5	12.0	39.2	12.7	7.9	3.0
LOS	C	B	D	B	A	A
Approach Delay	22.2			13.7	7.2	
Approach LOS	C			B	A	

Intersection Summary

Cycle Length: 90  
 Actuated Cycle Length: 64.9  
 Natural Cycle: 90  
 Control Type: Actuated-Uncoordinated  
 Maximum v/c Ratio: 0.75  
 Intersection Signal Delay: 12.5  
 Intersection LOS: B  
 Intersection Capacity Utilization 75.8%  
 ICU Level of Service D  
 Analysis Period (min) 15

Splits and Phases: 4: Temescal Canyon Rd & Trilogy Pkwy

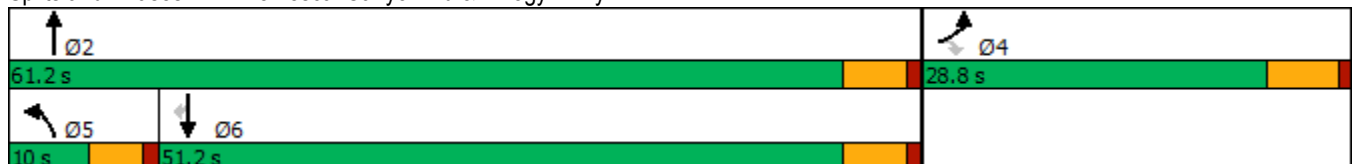



HCM 6th Signalized Intersection Summary  
4: Temescal Canyon Rd & Trilogy Pkwy

Glen Ivy Senior Living (JN 13030)  
09/11/2020



Movement	EBL	EBR	NBL	NBT	SBT	SBR
Lane Configurations						
Traffic Volume (veh/h)	47	20	41	1156	322	51
Future Volume (veh/h)	47	20	41	1156	322	51
Initial Q (Qb), veh	0	0	0	0	0	0
Ped-Bike Adj(A_pbT)	1.00	1.00	1.00			1.00
Parking Bus, Adj	1.00	1.00	1.00	1.00	1.00	1.00
Work Zone On Approach	No			No	No	
Adj Sat Flow, veh/h/ln	1900	1900	1900	1900	1900	1900
Adj Flow Rate, veh/h	48	8	42	1180	329	50
Peak Hour Factor	0.98	0.98	0.98	0.98	0.98	0.98
Percent Heavy Veh, %	0	0	0	0	0	0
Cap, veh/h	244	217	96	1377	1142	968
Arrive On Green	0.13	0.13	0.05	0.72	0.60	0.60
Sat Flow, veh/h	1810	1610	1810	1900	1900	1610
Grp Volume(v), veh/h	48	8	42	1180	329	50
Grp Sat Flow(s),veh/h/ln	1810	1610	1810	1900	1900	1610
Q Serve(g_s), s	1.3	0.2	1.3	25.7	4.8	0.7
Cycle Q Clear(g_c), s	1.3	0.2	1.3	25.7	4.8	0.7
Prop In Lane	1.00	1.00	1.00			1.00
Lane Grp Cap(c), veh/h	244	217	96	1377	1142	968
V/C Ratio(X)	0.20	0.04	0.44	0.86	0.29	0.05
Avail Cap(c_a), veh/h	788	701	191	1909	1575	1335
HCM Platoon Ratio	1.00	1.00	1.00	1.00	1.00	1.00
Upstream Filter(I)	1.00	1.00	1.00	1.00	1.00	1.00
Uniform Delay (d), s/veh	21.9	21.4	26.1	5.7	5.5	4.7
Incr Delay (d2), s/veh	0.4	0.1	1.2	3.0	0.1	0.0
Initial Q Delay(d3),s/veh	0.0	0.0	0.0	0.0	0.0	0.0
%ile BackOfQ(50%),veh/ln	0.5	0.0	0.5	4.3	1.2	0.2
Unsig. Movement Delay, s/veh						
LnGrp Delay(d),s/veh	22.3	21.5	27.3	8.7	5.6	4.7
LnGrp LOS	C	C	C	A	A	A
Approach Vol, veh/h	56			1222	379	
Approach Delay, s/veh	22.2			9.3	5.5	
Approach LOS	C			A	A	
Timer - Assigned Phs		2		4	5	6
Phs Duration (G+Y+Rc), s		45.3		11.7	7.0	38.2
Change Period (Y+Rc), s		5.4		5.8	4.6	5.4
Max Green Setting (Gmax), s		55.8		23.0	5.4	45.8
Max Q Clear Time (g_c+I1), s		27.7		3.3	3.3	6.8
Green Ext Time (p_c), s		12.2		0.1	0.0	2.1
<b>Intersection Summary</b>						
HCM 6th Ctrl Delay			8.9			
HCM 6th LOS			A			

Intersection						
Int Delay, s/veh	0					
Movement	EBL	EBR	NBL	NBT	SBT	SBR
Lane Configurations		↗		↑	↘	
Traffic Vol, veh/h	0	1	0	1196	333	10
Future Vol, veh/h	0	1	0	1196	333	10
Conflicting Peds, #/hr	0	0	0	0	0	0
Sign Control	Stop	Stop	Free	Free	Free	Free
RT Channelized	-	None	-	None	-	None
Storage Length	-	0	-	-	-	-
Veh in Median Storage, #	0	-	-	0	0	-
Grade, %	0	-	-	0	0	-
Peak Hour Factor	92	92	92	92	92	92
Heavy Vehicles, %	0	0	0	0	0	0
Mvmt Flow	0	1	0	1300	362	11

Major/Minor	Minor2	Major1	Major2		
Conflicting Flow All	-	368	-	0	-
Stage 1	-	-	-	-	-
Stage 2	-	-	-	-	-
Critical Hdwy	-	6.2	-	-	-
Critical Hdwy Stg 1	-	-	-	-	-
Critical Hdwy Stg 2	-	-	-	-	-
Follow-up Hdwy	-	3.3	-	-	-
Pot Cap-1 Maneuver	0	682	0	-	-
Stage 1	0	-	0	-	-
Stage 2	0	-	0	-	-
Platoon blocked, %				-	-
Mov Cap-1 Maneuver	-	682	-	-	-
Mov Cap-2 Maneuver	-	-	-	-	-
Stage 1	-	-	-	-	-
Stage 2	-	-	-	-	-

Approach	EB	NB	SB
HCM Control Delay, s	10.3	0	0
HCM LOS	B		

Minor Lane/Major Mvmt	NBT	EBLn1	SBT	SBR
Capacity (veh/h)	-	682	-	-
HCM Lane V/C Ratio	-	0.002	-	-
HCM Control Delay (s)	-	10.3	-	-
HCM Lane LOS	-	B	-	-
HCM 95th %tile Q(veh)	-	0	-	-

Intersection						
Int Delay, s/veh	0.2					
Movement	EBL	EBR	NBL	NBT	SBT	SBR
Lane Configurations	Y		Y	↑	↑	
Traffic Vol, veh/h	5	3	4	1192	331	4
Future Vol, veh/h	5	3	4	1192	331	4
Conflicting Peds, #/hr	0	0	0	0	0	0
Sign Control	Stop	Stop	Free	Free	Free	Free
RT Channelized	-	None	-	None	-	None
Storage Length	0	-	100	-	-	-
Veh in Median Storage, #	0	-	-	0	0	-
Grade, %	0	-	-	0	0	-
Peak Hour Factor	92	92	92	92	92	92
Heavy Vehicles, %	0	0	0	0	0	0
Mvmt Flow	5	3	4	1296	360	4

Major/Minor	Minor2	Major1	Major2			
Conflicting Flow All	1666	362	364	0	-	0
Stage 1	362	-	-	-	-	-
Stage 2	1304	-	-	-	-	-
Critical Hdwy	6.4	6.2	4.1	-	-	-
Critical Hdwy Stg 1	5.4	-	-	-	-	-
Critical Hdwy Stg 2	5.4	-	-	-	-	-
Follow-up Hdwy	3.5	3.3	2.2	-	-	-
Pot Cap-1 Maneuver	107	687	1206	-	-	-
Stage 1	709	-	-	-	-	-
Stage 2	257	-	-	-	-	-
Platoon blocked, %				-	-	-
Mov Cap-1 Maneuver	107	687	1206	-	-	-
Mov Cap-2 Maneuver	107	-	-	-	-	-
Stage 1	707	-	-	-	-	-
Stage 2	257	-	-	-	-	-

Approach	EB	NB	SB
HCM Control Delay, s	29.3	0	0
HCM LOS	D		

Minor Lane/Major Mvmt	NBL	NBT	EBLn1	SBT	SBR
Capacity (veh/h)	1206	-	157	-	-
HCM Lane V/C Ratio	0.004	-	0.055	-	-
HCM Control Delay (s)	8	-	29.3	-	-
HCM Lane LOS	A	-	D	-	-
HCM 95th %tile Q(veh)	0	-	0.2	-	-

Intersection						
Int Delay, s/veh	0.4					
Movement	EBT	EBR	WBL	WBT	NBL	NBR
Lane Configurations	↑↑		↖	↑↑	↘	
Traffic Vol, veh/h	189	1	5	123	4	5
Future Vol, veh/h	189	1	5	123	4	5
Conflicting Peds, #/hr	0	0	0	0	0	0
Sign Control	Free	Free	Free	Free	Stop	Stop
RT Channelized	-	None	-	None	-	None
Storage Length	-	-	100	-	0	-
Veh in Median Storage, #	0	-	-	0	0	-
Grade, %	0	-	-	0	0	-
Peak Hour Factor	92	92	92	92	92	92
Heavy Vehicles, %	0	0	0	0	0	0
Mvmt Flow	205	1	5	134	4	5

Major/Minor	Major1	Major2	Minor1		
Conflicting Flow All	0	0	206	0	283 103
Stage 1	-	-	-	-	206 -
Stage 2	-	-	-	-	77 -
Critical Hdwy	-	-	4.1	-	6.8 6.9
Critical Hdwy Stg 1	-	-	-	-	5.8 -
Critical Hdwy Stg 2	-	-	-	-	5.8 -
Follow-up Hdwy	-	-	2.2	-	3.5 3.3
Pot Cap-1 Maneuver	-	-	1377	-	689 938
Stage 1	-	-	-	-	814 -
Stage 2	-	-	-	-	943 -
Platoon blocked, %	-	-	-	-	-
Mov Cap-1 Maneuver	-	-	1377	-	686 938
Mov Cap-2 Maneuver	-	-	-	-	686 -
Stage 1	-	-	-	-	814 -
Stage 2	-	-	-	-	939 -

Approach	EB	WB	NB
HCM Control Delay, s	0	0.3	9.5
HCM LOS			A

Minor Lane/Major Mvmt	NBLn1	EBT	EBR	WBL	WBT
Capacity (veh/h)	806	-	-	1377	-
HCM Lane V/C Ratio	0.012	-	-	0.004	-
HCM Control Delay (s)	9.5	-	-	7.6	-
HCM Lane LOS	A	-	-	A	-
HCM 95th %tile Q(veh)	0	-	-	0	-



Intersection						
Int Delay, s/veh	0.3					
Movement	EBT	EBR	WBL	WBT	NBL	NBR
Lane Configurations	↑↑			↑↑		↑
Traffic Vol, veh/h	193	1	0	128	0	13
Future Vol, veh/h	193	1	0	128	0	13
Conflicting Peds, #/hr	0	0	0	0	0	0
Sign Control	Free	Free	Free	Free	Stop	Stop
RT Channelized	-	None	-	None	-	None
Storage Length	-	-	-	-	-	0
Veh in Median Storage, #	0	-	-	0	0	-
Grade, %	0	-	-	0	0	-
Peak Hour Factor	92	92	92	92	92	92
Heavy Vehicles, %	0	0	0	0	0	0
Mvmt Flow	210	1	0	139	0	14

Major/Minor	Major1	Major2	Minor1	Minor2	Minor3
Conflicting Flow All	0	0	-	-	106
Stage 1	-	-	-	-	-
Stage 2	-	-	-	-	-
Critical Hdwy	-	-	-	-	6.9
Critical Hdwy Stg 1	-	-	-	-	-
Critical Hdwy Stg 2	-	-	-	-	-
Follow-up Hdwy	-	-	-	-	3.3
Pot Cap-1 Maneuver	-	-	0	-	934
Stage 1	-	-	0	-	-
Stage 2	-	-	0	-	-
Platoon blocked, %	-	-	-	-	-
Mov Cap-1 Maneuver	-	-	-	-	934
Mov Cap-2 Maneuver	-	-	-	-	-
Stage 1	-	-	-	-	-
Stage 2	-	-	-	-	-

Approach	EB	WB	NB
HCM Control Delay, s	0	0	8.9
HCM LOS			A

Minor Lane/Major Mvmt	NBLn1	EBT	EBR	WBT
Capacity (veh/h)	934	-	-	-
HCM Lane V/C Ratio	0.015	-	-	-
HCM Control Delay (s)	8.9	-	-	-
HCM Lane LOS	A	-	-	-
HCM 95th %tile Q(veh)	0	-	-	-

Intersection						
Int Delay, s/veh	1					
Movement	EBL	EBR	NBL	NBT	SBT	SBR
Lane Configurations	↔		↔	↑	↑	
Traffic Vol, veh/h	40	22	29	465	593	78
Future Vol, veh/h	40	22	29	465	593	78
Conflicting Peds, #/hr	0	0	0	0	0	0
Sign Control	Stop	Stop	Free	Free	Free	Free
RT Channelized	-	None	-	None	-	None
Storage Length	0	-	200	-	-	-
Veh in Median Storage, #	2	-	-	0	0	-
Grade, %	0	-	-	0	0	-
Peak Hour Factor	94	94	94	94	94	94
Heavy Vehicles, %	0	0	0	0	0	0
Mvmt Flow	43	23	31	495	631	83

Major/Minor	Minor2	Major1	Major2			
Conflicting Flow All	1230	673	714	0	-	0
Stage 1	673	-	-	-	-	-
Stage 2	557	-	-	-	-	-
Critical Hdwy	6.4	6.2	4.1	-	-	-
Critical Hdwy Stg 1	5.4	-	-	-	-	-
Critical Hdwy Stg 2	5.4	-	-	-	-	-
Follow-up Hdwy	3.5	3.3	2.2	-	-	-
Pot Cap-1 Maneuver	198	459	895	-	-	-
Stage 1	511	-	-	-	-	-
Stage 2	578	-	-	-	-	-
Platoon blocked, %				-	-	-
Mov Cap-1 Maneuver	191	459	895	-	-	-
Mov Cap-2 Maneuver	395	-	-	-	-	-
Stage 1	493	-	-	-	-	-
Stage 2	578	-	-	-	-	-

Approach	EB	NB	SB
HCM Control Delay, s	15.3	0.5	0
HCM LOS	C		

Minor Lane/Major Mvmt	NBL	NBT	EBLn1	SBT	SBR
Capacity (veh/h)	895	-	416	-	-
HCM Lane V/C Ratio	0.034	-	0.159	-	-
HCM Control Delay (s)	9.2	-	15.3	-	-
HCM Lane LOS	A	-	C	-	-
HCM 95th %tile Q(veh)	0.1	-	0.6	-	-

Timings  
4: Temescal Canyon Rd & Trilogy Pkwy



Lane Group	EBL	EBR	NBL	NBT	SBT	SBR
Lane Configurations	↖	↗	↖	↑	↑	↗
Traffic Volume (vph)	163	42	42	331	528	87
Future Volume (vph)	163	42	42	331	528	87
Turn Type	Prot	Perm	Prot	NA	NA	Perm
Protected Phases	4		5	2	6	
Permitted Phases		4				6
Detector Phase	4	4	5	2	6	6
Switch Phase						
Minimum Initial (s)	10.0	10.0	5.0	10.0	10.0	10.0
Minimum Split (s)	28.8	28.8	9.6	15.4	33.4	33.4
Total Split (s)	31.0	31.0	11.0	59.0	48.0	48.0
Total Split (%)	34.4%	34.4%	12.2%	65.6%	53.3%	53.3%
Yellow Time (s)	4.8	4.8	3.6	4.4	4.4	4.4
All-Red Time (s)	1.0	1.0	1.0	1.0	1.0	1.0
Lost Time Adjust (s)	-1.8	-1.8	-0.6	-1.4	-1.4	-1.4
Total Lost Time (s)	4.0	4.0	4.0	4.0	4.0	4.0
Lead/Lag			Lead		Lag	Lag
Lead-Lag Optimize?			Yes		Yes	Yes
Recall Mode	None	None	None	None	None	None
Act Effct Green (s)	18.1	18.1	8.2	31.0	28.1	28.1
Actuated g/C Ratio	0.37	0.37	0.17	0.64	0.58	0.58
v/c Ratio	0.25	0.07	0.14	0.28	0.50	0.10
Control Delay	19.2	7.8	29.3	6.8	12.9	4.6
Queue Delay	0.0	0.0	0.0	0.0	0.0	0.0
Total Delay	19.2	7.8	29.3	6.8	12.9	4.6
LOS	B	A	C	A	B	A
Approach Delay	16.8			9.4	11.7	
Approach LOS	B			A	B	

Intersection Summary

Cycle Length: 90  
 Actuated Cycle Length: 48.3  
 Natural Cycle: 75  
 Control Type: Actuated-Uncoordinated  
 Maximum v/c Ratio: 0.50  
 Intersection Signal Delay: 11.9  
 Intersection LOS: B  
 Intersection Capacity Utilization 50.6%  
 ICU Level of Service A  
 Analysis Period (min) 15

Splits and Phases: 4: Temescal Canyon Rd & Trilogy Pkwy



HCM 6th Signalized Intersection Summary  
4: Temescal Canyon Rd & Trilogy Pkwy

Glen Ivy Senior Living (JN 13030)  
09/11/2020



Movement	EBL	EBR	NBL	NBT	SBT	SBR
Lane Configurations						
Traffic Volume (veh/h)	163	42	42	331	528	87
Future Volume (veh/h)	163	42	42	331	528	87
Initial Q (Qb), veh	0	0	0	0	0	0
Ped-Bike Adj(A_pbT)	1.00	1.00	1.00			0.98
Parking Bus, Adj	1.00	1.00	1.00	1.00	1.00	1.00
Work Zone On Approach	No			No	No	
Adj Sat Flow, veh/h/ln	1900	1900	1900	1900	1900	1900
Adj Flow Rate, veh/h	170	28	44	345	550	79
Peak Hour Factor	0.96	0.96	0.96	0.96	0.96	0.96
Percent Heavy Veh, %	0	0	0	0	0	0
Cap, veh/h	456	405	111	1070	777	645
Arrive On Green	0.25	0.25	0.06	0.56	0.41	0.41
Sat Flow, veh/h	1810	1610	1810	1900	1900	1577
Grp Volume(v), veh/h	170	28	44	345	550	79
Grp Sat Flow(s),veh/h/ln	1810	1610	1810	1900	1900	1577
Q Serve(g_s), s	3.3	0.6	1.0	4.2	10.4	1.3
Cycle Q Clear(g_c), s	3.3	0.6	1.0	4.2	10.4	1.3
Prop In Lane	1.00	1.00	1.00			1.00
Lane Grp Cap(c), veh/h	456	405	111	1070	777	645
V/C Ratio(X)	0.37	0.07	0.40	0.32	0.71	0.12
Avail Cap(c_a), veh/h	1132	1007	293	2421	1937	1607
HCM Platoon Ratio	1.00	1.00	1.00	1.00	1.00	1.00
Upstream Filter(I)	1.00	1.00	1.00	1.00	1.00	1.00
Uniform Delay (d), s/veh	13.3	12.3	19.5	5.0	10.6	7.9
Incr Delay (d2), s/veh	0.5	0.1	0.9	0.2	1.2	0.1
Initial Q Delay(d3),s/veh	0.0	0.0	0.0	0.0	0.0	0.0
%ile BackOfQ(50%),veh/ln	1.1	0.6	0.4	0.9	3.2	0.3
Unsig. Movement Delay, s/veh						
LnGrp Delay(d),s/veh	13.8	12.4	20.3	5.2	11.8	8.0
LnGrp LOS	B	B	C	A	B	A
Approach Vol, veh/h	198			389	629	
Approach Delay, s/veh	13.6			6.9	11.3	
Approach LOS	B			A	B	
Timer - Assigned Phs		2		4	5	6
Phs Duration (G+Y+Rc), s		28.3		14.9	6.6	21.7
Change Period (Y+Rc), s		5.4		5.8	4.6	5.4
Max Green Setting (Gmax), s		53.6		25.2	6.4	42.6
Max Q Clear Time (g_c+1), s		6.2		5.3	3.0	12.4
Green Ext Time (p_c), s		2.1		0.5	0.0	3.9
<b>Intersection Summary</b>						
HCM 6th Ctrl Delay			10.3			
HCM 6th LOS			B			



Intersection						
Int Delay, s/veh	0					
Movement	EBL	EBR	NBL	NBT	SBT	SBR
Lane Configurations		↗		↑	↘	
Traffic Vol, veh/h	0	3	0	373	559	11
Future Vol, veh/h	0	3	0	373	559	11
Conflicting Peds, #/hr	0	0	0	0	0	0
Sign Control	Stop	Stop	Free	Free	Free	Free
RT Channelized	-	None	-	None	-	None
Storage Length	-	0	-	-	-	-
Veh in Median Storage, #	0	-	-	0	0	-
Grade, %	0	-	-	0	0	-
Peak Hour Factor	92	92	92	92	92	92
Heavy Vehicles, %	0	0	0	0	0	0
Mvmt Flow	0	3	0	405	608	12

Major/Minor	Minor2	Major1	Major2		
Conflicting Flow All	-	614	-	0	0
Stage 1	-	-	-	-	-
Stage 2	-	-	-	-	-
Critical Hdwy	-	6.2	-	-	-
Critical Hdwy Stg 1	-	-	-	-	-
Critical Hdwy Stg 2	-	-	-	-	-
Follow-up Hdwy	-	3.3	-	-	-
Pot Cap-1 Maneuver	0	496	0	-	-
Stage 1	0	-	0	-	-
Stage 2	0	-	0	-	-
Platoon blocked, %				-	-
Mov Cap-1 Maneuver	-	496	-	-	-
Mov Cap-2 Maneuver	-	-	-	-	-
Stage 1	-	-	-	-	-
Stage 2	-	-	-	-	-

Approach	EB	NB	SB
HCM Control Delay, s	12.3	0	0
HCM LOS	B		

Minor Lane/Major Mvmt	NBT EBLn1	SBT	SBR
Capacity (veh/h)	- 496	-	-
HCM Lane V/C Ratio	- 0.007	-	-
HCM Control Delay (s)	- 12.3	-	-
HCM Lane LOS	- B	-	-
HCM 95th %tile Q(veh)	- 0	-	-

Intersection						
Int Delay, s/veh	0.3					
Movement	EBL	EBR	NBL	NBT	SBT	SBR
Lane Configurations	Y		Y	↑	↑	
Traffic Vol, veh/h	8	5	4	365	557	4
Future Vol, veh/h	8	5	4	365	557	4
Conflicting Peds, #/hr	0	0	0	0	0	0
Sign Control	Stop	Stop	Free	Free	Free	Free
RT Channelized	-	None	-	None	-	None
Storage Length	0	-	100	-	-	-
Veh in Median Storage, #	0	-	-	0	0	-
Grade, %	0	-	-	0	0	-
Peak Hour Factor	92	92	92	92	92	92
Heavy Vehicles, %	0	0	0	0	0	0
Mvmt Flow	9	5	4	397	605	4

Major/Minor	Minor2	Major1	Major2			
Conflicting Flow All	1012	607	609	0	-	0
Stage 1	607	-	-	-	-	-
Stage 2	405	-	-	-	-	-
Critical Hdwy	6.4	6.2	4.1	-	-	-
Critical Hdwy Stg 1	5.4	-	-	-	-	-
Critical Hdwy Stg 2	5.4	-	-	-	-	-
Follow-up Hdwy	3.5	3.3	2.2	-	-	-
Pot Cap-1 Maneuver	267	500	979	-	-	-
Stage 1	548	-	-	-	-	-
Stage 2	678	-	-	-	-	-
Platoon blocked, %				-	-	-
Mov Cap-1 Maneuver	266	500	979	-	-	-
Mov Cap-2 Maneuver	266	-	-	-	-	-
Stage 1	546	-	-	-	-	-
Stage 2	678	-	-	-	-	-

Approach	EB	NB	SB
HCM Control Delay, s	16.6	0.1	0
HCM LOS	C		

Minor Lane/Major Mvmt	NBL	NBT	EBLn1	SBT	SBR
Capacity (veh/h)	979	-	324	-	-
HCM Lane V/C Ratio	0.004	-	0.044	-	-
HCM Control Delay (s)	8.7	-	16.6	-	-
HCM Lane LOS	A	-	C	-	-
HCM 95th %tile Q(veh)	0	-	0.1	-	-

**APPENDIX 5.3:**

**EAP (2023) CONDITIONS TRAFFIC SIGNAL WARRANT ANALYSIS WORKSHEETS**

This Page Intentionally Left Blank



### Figure 4C-4. Warrant 3, Peak Hour (70% Factor)

(COMMUNITY LESS THAN 10,000 POPULATION OR ABOVE 64 km/h OR ABOVE 40 mph ON MAJOR STREET)

Traffic Conditions = **EAP (2023) Conditions - Weekday AM Peak Hour**

Major Street Name = **Temescal Canyon Rd.** Total of Both Approaches (VPH) = **1600**  
 Number of Approach Lanes Major Street = **1**

Minor Street Name = **Lawson Rd.** High Volume Approach (VPH) = **69**  
 Number of Approach Lanes Minor Street = **1**

**SIGNAL WARRANT NOT SATISFIED**

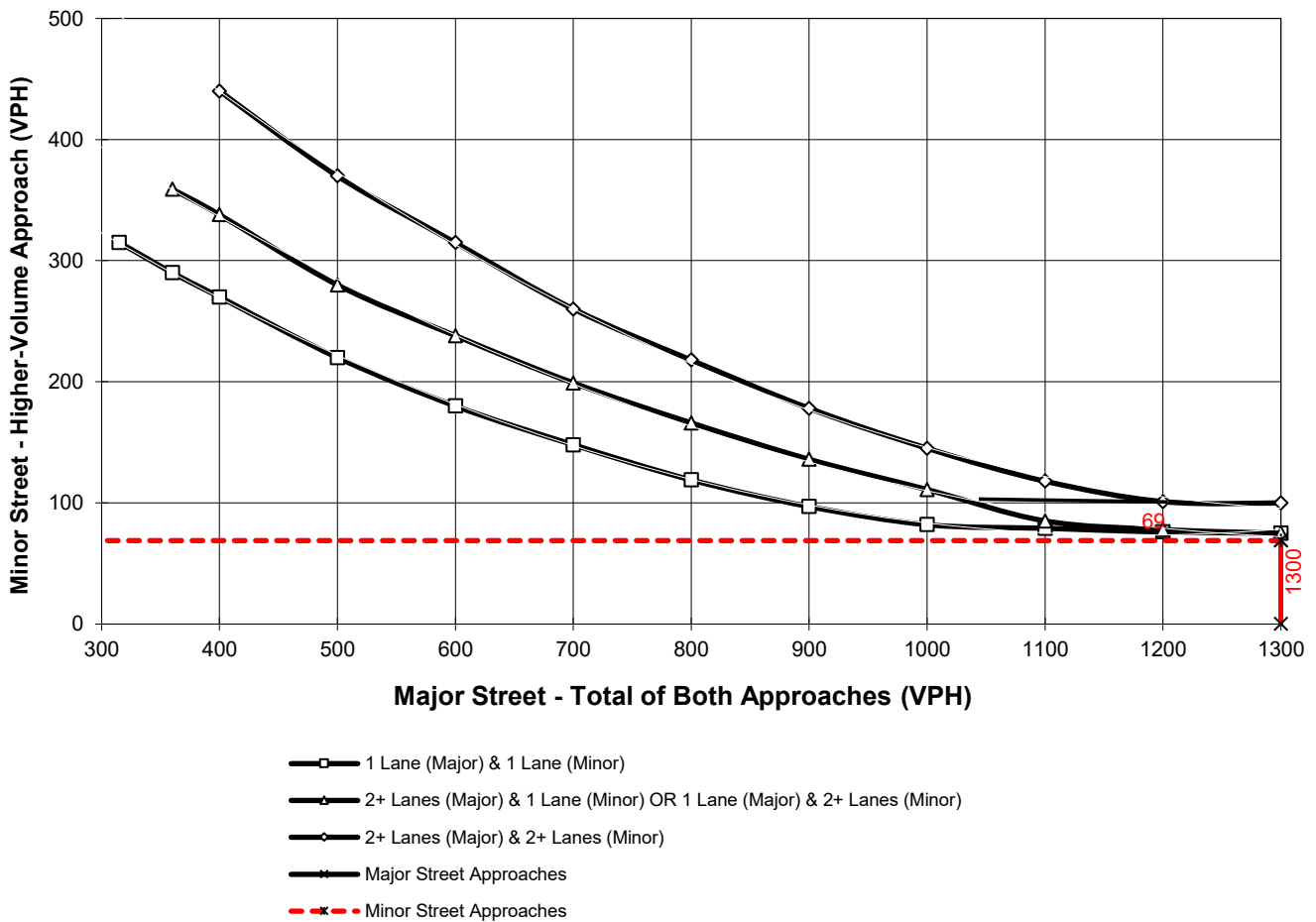

\*Note: 100 vph applies as the lower threshold for a minor-street approach with two or more lanes and 75 vph applies as the lower threshold for a minor-street approach with one lane

### Figure 4C-103 (CA). Traffic Signal Warrants Worksheet (Average Traffic Estimate Form)

<u>DIST</u>	<u>CO</u>	<u>RTE</u>	<u>PM</u>	CALC <u>CS</u>	TRAFFIC CONDITIONS	<u>EAP 2023</u>	
Jurisdiction: <u>County of Riverside</u>				CHK <u>CS</u>		DATE <u>09/03/20</u>	
Major Street: <u>Trilogy Pkwy.</u>					Critical Approach Speed (Major) <u>45</u> mph	DATE <u>09/03/20</u>	
Minor Street: <u>Driveway 1</u>					Critical Approach Speed (Minor) <u>25</u> mph		
Major Street Approach Lanes =			<u>1</u>	lane	Minor Street Approach Lanes:	<u>1</u> lane	
Major Street Future ADT =			<u>5,176</u>	vpd	Minor Street Future ADT =	<u>134</u> vpd	
Speed limit or critical speed on major street traffic > 64 km/h (40 mph); .....						<input checked="" type="checkbox"/>	
						or	<b>RURAL (R)</b>
In built up area of isolated community of < 10,000 population .....						<input type="checkbox"/>	

**(Based on Estimated Average Daily Traffic - See Note)**

		Minimum Requirements EADT			
<u>URBAN</u>	<u>RURAL</u>				
<b>CONDITION A - Minimum Vehicular Volume</b>	<b>XX</b>				
<u>Satisfied</u>	<u>Not Satisfied</u>				
		Vehicles Per Day on Major Street (Total of Both Approaches)		Vehicles Per Day on Higher-Volume Minor Street Approach (One Direction Only)	
		<u>Urban</u>	<u>Rural</u>	<u>Urban</u>	<u>Rural</u>
Number of lanes for moving traffic on each approach					
<u>Major Street</u>	<u>Minor Street</u>				
1 <b>5,176</b>	1 <b>134</b>				
2 +	1	8,000	5,600	2,400	1,680
2 +	2 +	9,600	6,720	2,400	1,680
1	2 +	9,600	6,720	3,200	2,240
		8,000	5,600	3,200	2,240
<b>CONDITION B - Interruption of Continuous Traffic</b>	<b>XX</b>				
<u>Satisfied</u>	<u>Not Satisfied</u>				
		Vehicles Per Day on Major Street (Total of Both Approaches)		Vehicles Per Day on Higher-Volume Minor Street Approach (One Direction Only)	
		<u>Urban</u>	<u>Rural</u>	<u>Urban</u>	<u>Rural</u>
Number of lanes for moving traffic on each approach					
<u>Major Street</u>	<u>Minor Street</u>				
1 <b>5,176</b>	1 <b>134</b>				
2 +	1	12,000	8,400	1,200	850
2 +	2 +	14,400	10,080	1,200	850
1	2 +	14,400	10,080	1,600	1,120
		12,000	8,400	1,600	1,120
<b>Combination of CONDITIONS A + B</b>					
<u>Satisfied</u>	<u>Not Satisfied</u>				
		2 CONDITIONS 80%		2 CONDITIONS 80%	
No one condition satisfied, but following conditions fulfilled 80% of more .....					
	<b>XX</b>				
	<b>A</b>				
	<b>8%</b>				
	<b>B</b>				
	<b>16%</b>				

**Note: To be used only for NEW INTERSECTIONS or other locations where it is not reasonable to count actual traffic volumes.**

The satisfaction of a traffic signal warrant or warrants shall not in itself require the installation of a traffic control signal.



### Figure 4C-103 (CA). Traffic Signal Warrants Worksheet (Average Traffic Estimate Form)

<u>DIST</u>	<u>CO</u>	<u>RTE</u>	<u>PM</u>	TRAFFIC CONDITIONS	<u>EAP 2023</u>
Jurisdiction: <u>County of Riverside</u>				CALC <u>CS</u>	DATE <u>09/03/20</u>
Major Street: <u>Temescal Canyon Rd.</u>				CHK <u>CS</u>	DATE <u>09/03/20</u>
Minor Street: <u>Driveway 4</u>				Critical Approach Speed (Major) <u>40</u> mph	
				Critical Approach Speed (Minor) <u>25</u> mph	
Major Street Approach Lanes =		<u>1</u>	lane	Minor Street Approach Lanes:	<u>1</u> lane
Major Street Future ADT =		<u>14,977</u>	vpd	Minor Street Future ADT =	<u>117</u> vpd
Speed limit or critical speed on major street traffic > 64 km/h (40 mph); .....					<input type="checkbox"/>
					or
In built up area of isolated community of < 10,000 population .....					<input type="checkbox"/>

**RURAL (R)**

**(Based on Estimated Average Daily Traffic - See Note)**

<u>URBAN</u>	<u>RURAL</u>	Minimum Requirements EADT			
<b>XX</b>					
<b>CONDITION A - Minimum Vehicular Volume</b>		Vehicles Per Day on Major Street		Vehicles Per Day on Higher-Volume Minor Street Approach	
<u>Satisfied</u>	<u>Not Satisfied</u>	(Total of Both Approaches)		(One Direction Only)	
	<b>XX</b>	Urban	Rural	Urban	Rural
Number of lanes for moving traffic on each approach					
<u>Major Street</u>	<u>Minor Street</u>				
1 <b>14,977</b>	1 <b>117</b>	8,000 *	5,600	2,400	1,680
2 +	1	9,600	6,720	2,400	1,680
2 +	2 +	9,600	6,720	3,200	2,240
1	2 +	8,000	5,600	3,200	2,240
<b>CONDITION B - Interruption of Continuous Traffic</b>		Vehicles Per Day on Major Street		Vehicles Per Day on Higher-Volume Minor Street Approach	
<u>Satisfied</u>	<u>Not Satisfied</u>	(Total of Both Approaches)		(One Direction Only)	
	<b>XX</b>	Urban	Rural	Urban	Rural
Number of lanes for moving traffic on each approach					
<u>Major Street</u>	<u>Minor Street</u>				
1 <b>14,977</b>	1 <b>117</b>	12,000 *	8,400	1,200	850
2 +	1	14,400	10,080	1,200	850
2 +	2 +	14,400	10,080	1,600	1,120
1	2 +	12,000	8,400	1,600	1,120
<b>Combination of CONDITIONS A + B</b>		2 CONDITIONS		2 CONDITIONS	
<u>Satisfied</u>	<u>Not Satisfied</u>	80%		80%	
No one condition satisfied, but following conditions fulfilled 80% of more .....	<b>XX</b>				
	<b>A</b>				
	<b>5%</b>				
	<b>B</b>				
	<b>10%</b>				

**Note: To be used only for NEW INTERSECTIONS or other locations where it is not reasonable to count actual traffic volumes.**

The satisfaction of a traffic signal warrant or warrants shall not in itself require the installation of a traffic control signal.



This Page Intentionally Left Blank



**APPENDIX 6.1:**

**EAPC (2023 – RIRO AT DRIVEWAY 4) CONDITIONS INTERSECTION OPERATIONS  
ANALYSIS WORKSHEETS**

This Page Intentionally Left Blank

Intersection						
Int Delay, s/veh	0.4					
Movement	EBT	EBR	WBL	WBT	NBL	NBR
Lane Configurations	↑↑		↖	↑↑	↗	
Traffic Vol, veh/h	142	1	9	156	2	5
Future Vol, veh/h	142	1	9	156	2	5
Conflicting Peds, #/hr	0	0	0	0	0	0
Sign Control	Free	Free	Free	Free	Stop	Stop
RT Channelized	-	None	-	None	-	None
Storage Length	-	-	100	-	0	-
Veh in Median Storage, #	0	-	-	0	0	-
Grade, %	0	-	-	0	0	-
Peak Hour Factor	92	92	92	92	92	92
Heavy Vehicles, %	0	0	0	0	0	0
Mvmt Flow	154	1	10	170	2	5

Major/Minor	Major1	Major2	Minor1		
Conflicting Flow All	0	0	155	0	260 78
Stage 1	-	-	-	-	155 -
Stage 2	-	-	-	-	105 -
Critical Hdwy	-	-	4.1	-	6.8 6.9
Critical Hdwy Stg 1	-	-	-	-	5.8 -
Critical Hdwy Stg 2	-	-	-	-	5.8 -
Follow-up Hdwy	-	-	2.2	-	3.5 3.3
Pot Cap-1 Maneuver	-	-	1438	-	712 973
Stage 1	-	-	-	-	863 -
Stage 2	-	-	-	-	914 -
Platoon blocked, %	-	-	-	-	-
Mov Cap-1 Maneuver	-	-	1438	-	707 973
Mov Cap-2 Maneuver	-	-	-	-	707 -
Stage 1	-	-	-	-	863 -
Stage 2	-	-	-	-	908 -

Approach	EB	WB	NB
HCM Control Delay, s	0	0.4	9.1
HCM LOS			A

Minor Lane/Major Mvmt	NBLn1	EBT	EBR	WBL	WBT
Capacity (veh/h)	879	-	-	1438	-
HCM Lane V/C Ratio	0.009	-	-	0.007	-
HCM Control Delay (s)	9.1	-	-	7.5	-
HCM Lane LOS	A	-	-	A	-
HCM 95th %tile Q(veh)	0	-	-	0	-

Intersection						
Int Delay, s/veh	0.2					
Movement	EBT	EBR	WBL	WBT	NBL	NBR
Lane Configurations	↑↑			↑↑		↑
Traffic Vol, veh/h	146	1	0	165	0	9
Future Vol, veh/h	146	1	0	165	0	9
Conflicting Peds, #/hr	0	0	0	0	0	0
Sign Control	Free	Free	Free	Free	Stop	Stop
RT Channelized	-	None	-	None	-	None
Storage Length	-	-	-	-	-	0
Veh in Median Storage, #	0	-	-	0	0	-
Grade, %	0	-	-	0	0	-
Peak Hour Factor	92	92	92	92	92	92
Heavy Vehicles, %	0	0	0	0	0	0
Mvmt Flow	159	1	0	179	0	10

Major/Minor	Major1	Major2	Minor1		
Conflicting Flow All	0	0	-	-	80
Stage 1	-	-	-	-	-
Stage 2	-	-	-	-	-
Critical Hdwy	-	-	-	-	6.9
Critical Hdwy Stg 1	-	-	-	-	-
Critical Hdwy Stg 2	-	-	-	-	-
Follow-up Hdwy	-	-	-	-	3.3
Pot Cap-1 Maneuver	-	0	-	0	971
Stage 1	-	0	-	0	-
Stage 2	-	0	-	0	-
Platoon blocked, %	-	-	-	-	-
Mov Cap-1 Maneuver	-	-	-	-	971
Mov Cap-2 Maneuver	-	-	-	-	-
Stage 1	-	-	-	-	-
Stage 2	-	-	-	-	-

Approach	EB	WB	NB
HCM Control Delay, s	0	0	8.7
HCM LOS			A

Minor Lane/Major Mvmt	NBLn1	EBT	EBR	WBT
Capacity (veh/h)	971	-	-	-
HCM Lane V/C Ratio	0.01	-	-	-
HCM Control Delay (s)	8.7	-	-	-
HCM Lane LOS	A	-	-	-
HCM 95th %tile Q(veh)	0	-	-	-



Intersection						
Int Delay, s/veh	31.7					
Movement	EBL	EBR	NBL	NBT	SBT	SBR
Lane Configurations						
Traffic Vol, veh/h	135	91	150	1334	504	124
Future Vol, veh/h	135	91	150	1334	504	124
Conflicting Peds, #/hr	0	0	0	0	0	0
Sign Control	Stop	Stop	Free	Free	Free	Free
RT Channelized	-	None	-	None	-	None
Storage Length	0	-	200	-	-	-
Veh in Median Storage, #	2	-	-	0	0	-
Grade, %	0	-	-	0	0	-
Peak Hour Factor	86	86	86	86	86	86
Heavy Vehicles, %	0	0	0	0	0	0
Mvmt Flow	157	106	174	1551	586	144

Major/Minor	Minor2	Major1	Major2			
Conflicting Flow All	2557	658	730	0	-	0
Stage 1	658	-	-	-	-	-
Stage 2	1899	-	-	-	-	-
Critical Hdwy	6.4	6.2	4.1	-	-	-
Critical Hdwy Stg 1	5.4	-	-	-	-	-
Critical Hdwy Stg 2	5.4	-	-	-	-	-
Follow-up Hdwy	3.5	3.3	2.2	-	-	-
Pot Cap-1 Maneuver	~ 30	468	883	-	-	-
Stage 1	519	-	-	-	-	-
Stage 2	~ 131	-	-	-	-	-
Platoon blocked, %				-	-	-
Mov Cap-1 Maneuver	~ 24	468	883	-	-	-
Mov Cap-2 Maneuver	~ 119	-	-	-	-	-
Stage 1	417	-	-	-	-	-
Stage 2	~ 131	-	-	-	-	-

Approach	EB	NB	SB
HCM Control Delay, s	321.7	1	0
HCM LOS	F		

Minor Lane/Major Mvmt	NBL	NBT	EBLn1	SBT	SBR
Capacity (veh/h)	883	-	170	-	-
HCM Lane V/C Ratio	0.198	-	1.546	-	-
HCM Control Delay (s)	10.1	-	321.7	-	-
HCM Lane LOS	B	-	F	-	-
HCM 95th %tile Q(veh)	0.7	-	17.3	-	-

Notes  
 ~: Volume exceeds capacity    \$: Delay exceeds 300s    +: Computation Not Defined    \*: All major volume in platoon

Timings  
4: Temescal Canyon Rd & Trilogy Pkwy



Lane Group	EBL	EBR	NBL	NBT	SBT	SBR
Lane Configurations	↖	↗	↖	↑	↑	↗
Traffic Volume (vph)	91	65	83	1393	515	81
Future Volume (vph)	91	65	83	1393	515	81
Turn Type	Prot	Perm	Prot	NA	NA	Perm
Protected Phases	4		5	2	6	
Permitted Phases		4				6
Detector Phase	4	4	5	2	6	6
Switch Phase						
Minimum Initial (s)	10.0	10.0	5.0	10.0	10.0	10.0
Minimum Split (s)	28.8	28.8	9.6	15.4	33.4	33.4
Total Split (s)	28.8	28.8	10.0	61.2	51.2	51.2
Total Split (%)	32.0%	32.0%	11.1%	68.0%	56.9%	56.9%
Yellow Time (s)	4.8	4.8	3.6	4.4	4.4	4.4
All-Red Time (s)	1.0	1.0	1.0	1.0	1.0	1.0
Lost Time Adjust (s)	-1.8	-1.8	-0.6	-1.4	-1.4	-1.4
Total Lost Time (s)	4.0	4.0	4.0	4.0	4.0	4.0
Lead/Lag			Lead		Lag	Lag
Lead-Lag Optimize?			Yes		Yes	Yes
Recall Mode	None	None	None	None	None	None
Act Effct Green (s)	14.3	14.3	6.1	59.1	51.5	51.5
Actuated g/C Ratio	0.19	0.19	0.08	0.77	0.67	0.67
v/c Ratio	0.28	0.19	0.59	0.97	0.41	0.07
Control Delay	30.0	8.5	56.1	31.4	10.4	3.2
Queue Delay	0.0	0.0	0.0	0.0	0.0	0.0
Total Delay	30.0	8.5	56.1	31.4	10.4	3.2
LOS	C	A	E	C	B	A
Approach Delay	21.1			32.8	9.4	
Approach LOS	C			C	A	

Intersection Summary

Cycle Length: 90	
Actuated Cycle Length: 76.6	
Natural Cycle: 120	
Control Type: Actuated-Uncoordinated	
Maximum v/c Ratio: 0.97	
Intersection Signal Delay: 25.7	Intersection LOS: C
Intersection Capacity Utilization 88.3%	ICU Level of Service E
Analysis Period (min) 15	

Splits and Phases: 4: Temescal Canyon Rd & Trilogy Pkwy

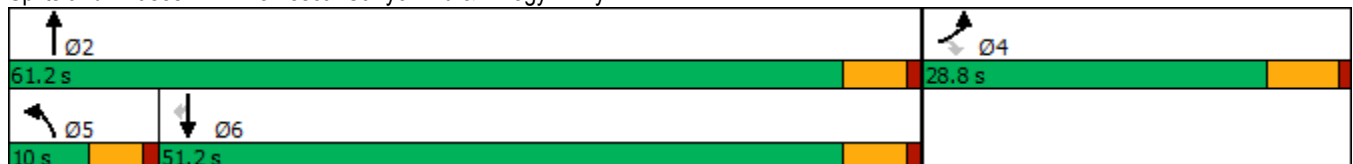

HCM 6th Signalized Intersection Summary  
 4: Temescal Canyon Rd & Trilogy Pkwy

Glen Ivy Senior Living (JN 13030)

09/11/2020



Movement	EBL	EBR	NBL	NBT	SBT	SBR
Lane Configurations						
Traffic Volume (veh/h)	91	65	83	1393	515	81
Future Volume (veh/h)	91	65	83	1393	515	81
Initial Q (Qb), veh	0	0	0	0	0	0
Ped-Bike Adj(A_pbT)	1.00	1.00	1.00			1.00
Parking Bus, Adj	1.00	1.00	1.00	1.00	1.00	1.00
Work Zone On Approach	No			No	No	
Adj Sat Flow, veh/h/ln	1900	1900	1900	1900	1900	1900
Adj Flow Rate, veh/h	93	54	85	1421	526	81
Peak Hour Factor	0.98	0.98	0.98	0.98	0.98	0.98
Percent Heavy Veh, %	0	0	0	0	0	0
Cap, veh/h	269	239	123	1420	1191	1009
Arrive On Green	0.15	0.15	0.07	0.75	0.63	0.63
Sat Flow, veh/h	1810	1610	1810	1900	1900	1610
Grp Volume(v), veh/h	93	54	85	1421	526	81
Grp Sat Flow(s),veh/h/ln	1810	1610	1810	1900	1900	1610
Q Serve(g_s), s	3.5	2.3	3.5	57.2	10.9	1.5
Cycle Q Clear(g_c), s	3.5	2.3	3.5	57.2	10.9	1.5
Prop In Lane	1.00	1.00	1.00			1.00
Lane Grp Cap(c), veh/h	269	239	123	1420	1191	1009
V/C Ratio(X)	0.35	0.23	0.69	1.00	0.44	0.08
Avail Cap(c_a), veh/h	586	522	142	1420	1191	1009
HCM Platoon Ratio	1.00	1.00	1.00	1.00	1.00	1.00
Upstream Filter(I)	1.00	1.00	1.00	1.00	1.00	1.00
Uniform Delay (d), s/veh	29.3	28.7	34.9	9.7	7.4	5.6
Incr Delay (d2), s/veh	0.8	0.5	8.1	24.1	0.3	0.0
Initial Q Delay(d3),s/veh	0.0	0.0	0.0	0.0	0.0	0.0
%ile BackOfQ(50%),veh/ln	1.5	2.2	1.7	21.0	3.4	0.4
Unsig. Movement Delay, s/veh						
LnGrp Delay(d),s/veh	30.0	29.2	43.0	33.8	7.6	5.6
LnGrp LOS	C	C	D	F	A	A
Approach Vol, veh/h	147			1506	607	
Approach Delay, s/veh	29.7			34.3	7.4	
Approach LOS	C			C	A	
Timer - Assigned Phs		2		4	5	6
Phs Duration (G+Y+Rc), s		61.2		15.4	9.2	52.0
Change Period (Y+Rc), s		5.4		5.8	4.6	5.4
Max Green Setting (Gmax), s		55.8		23.0	5.4	45.8
Max Q Clear Time (g_c+11), s		59.2		5.5	5.5	12.9
Green Ext Time (p_c), s		0.0		0.3	0.0	3.7
<b>Intersection Summary</b>						
HCM 6th Ctrl Delay			26.8			
HCM 6th LOS			C			

Intersection						
Int Delay, s/veh	0					
Movement	EBL	EBR	NBL	NBT	SBT	SBR
Lane Configurations		↗		↑	↘	
Traffic Vol, veh/h	0	1	0	1476	570	10
Future Vol, veh/h	0	1	0	1476	570	10
Conflicting Peds, #/hr	0	0	0	0	0	0
Sign Control	Stop	Stop	Free	Free	Free	Free
RT Channelized	-	None	-	None	-	None
Storage Length	-	0	-	-	-	-
Veh in Median Storage, #	0	-	-	0	0	-
Grade, %	0	-	-	0	0	-
Peak Hour Factor	92	92	92	92	92	92
Heavy Vehicles, %	0	0	0	0	0	0
Mvmt Flow	0	1	0	1604	620	11

Major/Minor	Minor2	Major1	Major2		
Conflicting Flow All	-	626	-	0	-
Stage 1	-	-	-	-	-
Stage 2	-	-	-	-	-
Critical Hdwy	-	6.2	-	-	-
Critical Hdwy Stg 1	-	-	-	-	-
Critical Hdwy Stg 2	-	-	-	-	-
Follow-up Hdwy	-	3.3	-	-	-
Pot Cap-1 Maneuver	0	488	0	-	-
Stage 1	0	-	0	-	-
Stage 2	0	-	0	-	-
Platoon blocked, %				-	-
Mov Cap-1 Maneuver	-	488	-	-	-
Mov Cap-2 Maneuver	-	-	-	-	-
Stage 1	-	-	-	-	-
Stage 2	-	-	-	-	-

Approach	EB	NB	SB
HCM Control Delay, s	12.4	0	0
HCM LOS	B		

Minor Lane/Major Mvmt	NBT EBLn1	SBT	SBR
Capacity (veh/h)	- 488	-	-
HCM Lane V/C Ratio	- 0.002	-	-
HCM Control Delay (s)	- 12.4	-	-
HCM Lane LOS	- B	-	-
HCM 95th %tile Q(veh)	- 0	-	-



Intersection						
Int Delay, s/veh	0					
Movement	EBL	EBR	NBL	NBT	SBT	SBR
Lane Configurations		↗		↑	↘	
Traffic Vol, veh/h	0	3	0	1476	568	4
Future Vol, veh/h	0	3	0	1476	568	4
Conflicting Peds, #/hr	0	0	0	0	0	0
Sign Control	Stop	Stop	Free	Free	Free	Free
RT Channelized	-	None	-	None	-	None
Storage Length	-	0	-	-	-	-
Veh in Median Storage, #	0	-	-	0	0	-
Grade, %	0	-	-	0	0	-
Peak Hour Factor	92	92	92	92	92	92
Heavy Vehicles, %	0	0	0	0	0	0
Mvmt Flow	0	3	0	1604	617	4

Major/Minor	Minor2	Major1	Major2		
Conflicting Flow All	-	619	-	0	-
Stage 1	-	-	-	-	-
Stage 2	-	-	-	-	-
Critical Hdwy	-	6.2	-	-	-
Critical Hdwy Stg 1	-	-	-	-	-
Critical Hdwy Stg 2	-	-	-	-	-
Follow-up Hdwy	-	3.3	-	-	-
Pot Cap-1 Maneuver	0	492	0	-	-
Stage 1	0	-	0	-	-
Stage 2	0	-	0	-	-
Platoon blocked, %				-	-
Mov Cap-1 Maneuver	-	492	-	-	-
Mov Cap-2 Maneuver	-	-	-	-	-
Stage 1	-	-	-	-	-
Stage 2	-	-	-	-	-

Approach	EB	NB	SB
HCM Control Delay, s	12.4	0	0
HCM LOS	B		

Minor Lane/Major Mvmt	NBT EBLn1	SBT	SBR
Capacity (veh/h)	- 492	-	-
HCM Lane V/C Ratio	- 0.007	-	-
HCM Control Delay (s)	- 12.4	-	-
HCM Lane LOS	- B	-	-
HCM 95th %tile Q(veh)	- 0	-	-

Intersection						
Int Delay, s/veh	0.4					
Movement	EBT	EBR	WBL	WBT	NBL	NBR
Lane Configurations	↑↑		↖	↑↑	↗	
Traffic Vol, veh/h	285	1	9	215	4	9
Future Vol, veh/h	285	1	9	215	4	9
Conflicting Peds, #/hr	0	0	0	0	0	0
Sign Control	Free	Free	Free	Free	Stop	Stop
RT Channelized	-	None	-	None	-	None
Storage Length	-	-	100	-	0	-
Veh in Median Storage, #	0	-	-	0	0	-
Grade, %	0	-	-	0	0	-
Peak Hour Factor	92	92	92	92	92	92
Heavy Vehicles, %	0	0	0	0	0	0
Mvmt Flow	310	1	10	234	4	10

Major/Minor	Major1	Major2	Minor1			
Conflicting Flow All	0	0	311	0	448	156
Stage 1	-	-	-	-	311	-
Stage 2	-	-	-	-	137	-
Critical Hdwy	-	-	4.1	-	6.8	6.9
Critical Hdwy Stg 1	-	-	-	-	5.8	-
Critical Hdwy Stg 2	-	-	-	-	5.8	-
Follow-up Hdwy	-	-	2.2	-	3.5	3.3
Pot Cap-1 Maneuver	-	-	1261	-	544	868
Stage 1	-	-	-	-	722	-
Stage 2	-	-	-	-	881	-
Platoon blocked, %	-	-	-	-	-	-
Mov Cap-1 Maneuver	-	-	1261	-	540	868
Mov Cap-2 Maneuver	-	-	-	-	540	-
Stage 1	-	-	-	-	722	-
Stage 2	-	-	-	-	874	-

Approach	EB	WB	NB
HCM Control Delay, s	0	0.3	10
HCM LOS			B

Minor Lane/Major Mvmt	NBLn1	EBT	EBR	WBL	WBT
Capacity (veh/h)	731	-	-	1261	-
HCM Lane V/C Ratio	0.019	-	-	0.008	-
HCM Control Delay (s)	10	-	-	7.9	-
HCM Lane LOS	B	-	-	A	-
HCM 95th %tile Q(veh)	0.1	-	-	0	-

Intersection						
Int Delay, s/veh	0.3					
Movement	EBT	EBR	WBL	WBT	NBL	NBR
Lane Configurations	↑↑			↑↑		↑
Traffic Vol, veh/h	293	1	0	224	0	16
Future Vol, veh/h	293	1	0	224	0	16
Conflicting Peds, #/hr	0	0	0	0	0	0
Sign Control	Free	Free	Free	Free	Stop	Stop
RT Channelized	-	None	-	None	-	None
Storage Length	-	-	-	-	-	0
Veh in Median Storage, #	0	-	-	0	0	-
Grade, %	0	-	-	0	0	-
Peak Hour Factor	92	92	92	92	92	92
Heavy Vehicles, %	0	0	0	0	0	0
Mvmt Flow	318	1	0	243	0	17

Major/Minor	Major1	Major2	Minor1		
Conflicting Flow All	0	0	-	-	160
Stage 1	-	-	-	-	-
Stage 2	-	-	-	-	-
Critical Hdwy	-	-	-	-	6.9
Critical Hdwy Stg 1	-	-	-	-	-
Critical Hdwy Stg 2	-	-	-	-	-
Follow-up Hdwy	-	-	-	-	3.3
Pot Cap-1 Maneuver	-	0	-	0	863
Stage 1	-	0	-	0	-
Stage 2	-	0	-	0	-
Platoon blocked, %	-	-	-	-	-
Mov Cap-1 Maneuver	-	-	-	-	863
Mov Cap-2 Maneuver	-	-	-	-	-
Stage 1	-	-	-	-	-
Stage 2	-	-	-	-	-

Approach	EB	WB	NB
HCM Control Delay, s	0	0	9.3
HCM LOS			A

Minor Lane/Major Mvmt	NBLn1	EBT	EBR	WBT
Capacity (veh/h)	863	-	-	-
HCM Lane V/C Ratio	0.02	-	-	-
HCM Control Delay (s)	9.3	-	-	-
HCM Lane LOS	A	-	-	-
HCM 95th %tile Q(veh)	0.1	-	-	-

Intersection						
Int Delay, s/veh	70.4					
Movement	EBL	EBR	NBL	NBT	SBT	SBR
Lane Configurations	↔		↔	↑	↑	
Traffic Vol, veh/h	280	106	127	639	807	312
Future Vol, veh/h	280	106	127	639	807	312
Conflicting Peds, #/hr	0	0	0	0	0	0
Sign Control	Stop	Stop	Free	Free	Free	Free
RT Channelized	-	None	-	None	-	None
Storage Length	0	-	200	-	-	-
Veh in Median Storage, #	2	-	-	0	0	-
Grade, %	0	-	-	0	0	-
Peak Hour Factor	94	94	94	94	94	94
Heavy Vehicles, %	0	0	0	0	0	0
Mvmt Flow	298	113	135	680	859	332

Major/Minor	Minor2	Major1	Major2			
Conflicting Flow All	1975	1025	1191	0	-	0
Stage 1	1025	-	-	-	-	-
Stage 2	950	-	-	-	-	-
Critical Hdwy	6.4	6.2	4.1	-	-	-
Critical Hdwy Stg 1	5.4	-	-	-	-	-
Critical Hdwy Stg 2	5.4	-	-	-	-	-
Follow-up Hdwy	3.5	3.3	2.2	-	-	-
Pot Cap-1 Maneuver	~ 69	288	593	-	-	-
Stage 1	349	-	-	-	-	-
Stage 2	379	-	-	-	-	-
Platoon blocked, %				-	-	-
Mov Cap-1 Maneuver	~ 53	288	593	-	-	-
Mov Cap-2 Maneuver	~ 212	-	-	-	-	-
Stage 1	~ 269	-	-	-	-	-
Stage 2	379	-	-	-	-	-

Approach	EB	NB	SB
HCM Control Delay, s	410.2	2.1	0
HCM LOS	F		

Minor Lane/Major Mvmt	NBL	NBT	EBLn1	SBT	SBR
Capacity (veh/h)	593	-	229	-	-
HCM Lane V/C Ratio	0.228	-	1.793	-	-
HCM Control Delay (s)	12.9	-	410.2	-	-
HCM Lane LOS	B	-	F	-	-
HCM 95th %tile Q(veh)	0.9	-	28.2	-	-

Notes  
 ~: Volume exceeds capacity    \$: Delay exceeds 300s    +: Computation Not Defined    \*: All major volume in platoon



Timings  
4: Temescal Canyon Rd & Trilogy Pkwy

Glen Ivy Senior Living (JN 13030)

09/11/2020



Lane Group	EBL	EBR	NBL	NBT	SBT	SBR
Lane Configurations	↖	↗	↖	↑	↑	↗
Traffic Volume (vph)	218	91	95	547	783	130
Future Volume (vph)	218	91	95	547	783	130
Turn Type	Prot	Perm	Prot	NA	NA	Perm
Protected Phases	4		5	2	6	
Permitted Phases		4				6
Detector Phase	4	4	5	2	6	6
Switch Phase						
Minimum Initial (s)	10.0	10.0	5.0	10.0	10.0	10.0
Minimum Split (s)	28.8	28.8	9.6	15.4	33.4	33.4
Total Split (s)	31.0	31.0	11.0	59.0	48.0	48.0
Total Split (%)	34.4%	34.4%	12.2%	65.6%	53.3%	53.3%
Yellow Time (s)	4.8	4.8	3.6	4.4	4.4	4.4
All-Red Time (s)	1.0	1.0	1.0	1.0	1.0	1.0
Lost Time Adjust (s)	-1.8	-1.8	-0.6	-1.4	-1.4	-1.4
Total Lost Time (s)	4.0	4.0	4.0	4.0	4.0	4.0
Lead/Lag			Lead		Lag	Lag
Lead-Lag Optimize?			Yes		Yes	Yes
Recall Mode	None	None	None	None	None	None
Act Effct Green (s)	17.7	17.7	7.2	45.1	37.1	37.1
Actuated g/C Ratio	0.25	0.25	0.10	0.63	0.52	0.52
v/c Ratio	0.51	0.20	0.54	0.47	0.83	0.16
Control Delay	30.7	7.0	49.3	8.5	24.7	6.2
Queue Delay	0.0	0.0	0.0	0.0	0.0	0.0
Total Delay	30.7	7.0	49.3	8.5	24.7	6.2
LOS	C	A	D	A	C	A
Approach Delay	23.7			14.5	22.1	
Approach LOS	C			B	C	

Intersection Summary

Cycle Length: 90	
Actuated Cycle Length: 71.4	
Natural Cycle: 80	
Control Type: Actuated-Uncoordinated	
Maximum v/c Ratio: 0.83	
Intersection Signal Delay: 19.7	Intersection LOS: B
Intersection Capacity Utilization 68.6%	ICU Level of Service C
Analysis Period (min) 15	

Splits and Phases: 4: Temescal Canyon Rd & Trilogy Pkwy

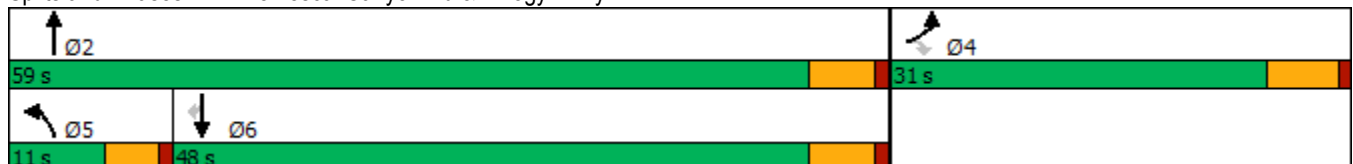

HCM 6th Signalized Intersection Summary  
4: Temescal Canyon Rd & Trilogy Pkwy

Glen Ivy Senior Living (JN 13030)

09/11/2020



Movement	EBL	EBR	NBL	NBT	SBT	SBR
Lane Configurations						
Traffic Volume (veh/h)	218	91	95	547	783	130
Future Volume (veh/h)	218	91	95	547	783	130
Initial Q (Qb), veh	0	0	0	0	0	0
Ped-Bike Adj(A_pbT)	1.00	1.00	1.00			0.98
Parking Bus, Adj	1.00	1.00	1.00	1.00	1.00	1.00
Work Zone On Approach	No			No	No	
Adj Sat Flow, veh/h/ln	1900	1900	1900	1900	1900	1900
Adj Flow Rate, veh/h	227	79	99	570	816	123
Peak Hour Factor	0.96	0.96	0.96	0.96	0.96	0.96
Percent Heavy Veh, %	0	0	0	0	0	0
Cap, veh/h	358	319	145	1267	987	819
Arrive On Green	0.20	0.20	0.08	0.67	0.52	0.52
Sat Flow, veh/h	1810	1610	1810	1900	1900	1577
Grp Volume(v), veh/h	227	79	99	570	816	123
Grp Sat Flow(s),veh/h/ln	1810	1610	1810	1900	1900	1577
Q Serve(g_s), s	6.8	2.5	3.2	8.5	21.4	2.4
Cycle Q Clear(g_c), s	6.8	2.5	3.2	8.5	21.4	2.4
Prop In Lane	1.00	1.00	1.00			1.00
Lane Grp Cap(c), veh/h	358	319	145	1267	987	819
V/C Ratio(X)	0.63	0.25	0.68	0.45	0.83	0.15
Avail Cap(c_a), veh/h	824	733	214	1763	1410	1170
HCM Platoon Ratio	1.00	1.00	1.00	1.00	1.00	1.00
Upstream Filter(I)	1.00	1.00	1.00	1.00	1.00	1.00
Uniform Delay (d), s/veh	21.8	20.0	26.5	4.7	12.0	7.4
Incr Delay (d2), s/veh	1.9	0.4	2.1	0.3	2.9	0.1
Initial Q Delay(d3),s/veh	0.0	0.0	0.0	0.0	0.0	0.0
%ile BackOfQ(50%),veh/ln	2.7	2.4	1.3	1.8	7.3	0.6
Unsig. Movement Delay, s/veh						
LnGrp Delay(d),s/veh	23.7	20.5	28.6	4.9	14.9	7.5
LnGrp LOS	C	C	C	A	B	A
Approach Vol, veh/h	306			669	939	
Approach Delay, s/veh	22.8			8.4	13.9	
Approach LOS	C			A	B	
Timer - Assigned Phs		2		4	5	6
Phs Duration (G+Y+Rc), s		43.5		15.7	8.8	34.8
Change Period (Y+Rc), s		5.4		5.8	4.6	5.4
Max Green Setting (Gmax), s		53.6		25.2	6.4	42.6
Max Q Clear Time (g_c+11), s		10.5		8.8	5.2	23.4
Green Ext Time (p_c), s		3.9		0.8	0.0	5.9
<b>Intersection Summary</b>						
HCM 6th Ctrl Delay			13.4			
HCM 6th LOS			B			

Intersection						
Int Delay, s/veh	0					
Movement	EBL	EBR	NBL	NBT	SBT	SBR
Lane Configurations		↗		↑	↘	
Traffic Vol, veh/h	0	3	0	642	863	11
Future Vol, veh/h	0	3	0	642	863	11
Conflicting Peds, #/hr	0	0	0	0	0	0
Sign Control	Stop	Stop	Free	Free	Free	Free
RT Channelized	-	None	-	None	-	None
Storage Length	-	0	-	-	-	-
Veh in Median Storage, #	0	-	-	0	0	-
Grade, %	0	-	-	0	0	-
Peak Hour Factor	92	92	92	92	92	92
Heavy Vehicles, %	0	0	0	0	0	0
Mvmt Flow	0	3	0	698	938	12

Major/Minor	Minor2	Major1	Major2			
Conflicting Flow All	-	944	-	0	-	0
Stage 1	-	-	-	-	-	-
Stage 2	-	-	-	-	-	-
Critical Hdwy	-	6.2	-	-	-	-
Critical Hdwy Stg 1	-	-	-	-	-	-
Critical Hdwy Stg 2	-	-	-	-	-	-
Follow-up Hdwy	-	3.3	-	-	-	-
Pot Cap-1 Maneuver	0	321	0	-	-	-
Stage 1	0	-	0	-	-	-
Stage 2	0	-	0	-	-	-
Platoon blocked, %				-	-	-
Mov Cap-1 Maneuver	-	321	-	-	-	-
Mov Cap-2 Maneuver	-	-	-	-	-	-
Stage 1	-	-	-	-	-	-
Stage 2	-	-	-	-	-	-

Approach	EB	NB	SB
HCM Control Delay, s	16.3	0	0
HCM LOS	C		

Minor Lane/Major Mvmt	NBT	EBLn1	SBT	SBR
Capacity (veh/h)	-	321	-	-
HCM Lane V/C Ratio	-	0.01	-	-
HCM Control Delay (s)	-	16.3	-	-
HCM Lane LOS	-	C	-	-
HCM 95th %tile Q(veh)	-	0	-	-

Intersection						
Int Delay, s/veh	0.1					
Movement	EBL	EBR	NBL	NBT	SBT	SBR
Lane Configurations		↗		↑	↘	
Traffic Vol, veh/h	0	5	0	642	861	4
Future Vol, veh/h	0	5	0	642	861	4
Conflicting Peds, #/hr	0	0	0	0	0	0
Sign Control	Stop	Stop	Free	Free	Free	Free
RT Channelized	-	None	-	None	-	None
Storage Length	-	0	-	-	-	-
Veh in Median Storage, #	0	-	-	0	0	-
Grade, %	0	-	-	0	0	-
Peak Hour Factor	92	92	92	92	92	92
Heavy Vehicles, %	0	0	0	0	0	0
Mvmt Flow	0	5	0	698	936	4

Major/Minor	Minor2	Major1	Major2		
Conflicting Flow All	-	938	-	0	-
Stage 1	-	-	-	-	-
Stage 2	-	-	-	-	-
Critical Hdwy	-	6.2	-	-	-
Critical Hdwy Stg 1	-	-	-	-	-
Critical Hdwy Stg 2	-	-	-	-	-
Follow-up Hdwy	-	3.3	-	-	-
Pot Cap-1 Maneuver	0	323	0	-	-
Stage 1	0	-	0	-	-
Stage 2	0	-	0	-	-
Platoon blocked, %				-	-
Mov Cap-1 Maneuver	-	323	-	-	-
Mov Cap-2 Maneuver	-	-	-	-	-
Stage 1	-	-	-	-	-
Stage 2	-	-	-	-	-

Approach	EB	NB	SB
HCM Control Delay, s	16.3	0	0
HCM LOS	C		

Minor Lane/Major Mvmt	NBT EBLn1	SBT	SBR
Capacity (veh/h)	- 323	-	-
HCM Lane V/C Ratio	- 0.017	-	-
HCM Control Delay (s)	- 16.3	-	-
HCM Lane LOS	- C	-	-
HCM 95th %tile Q(veh)	- 0.1	-	-

**APPENDIX 6.2:**

**EAPC (2023 – FULL ACCESS AT DRIVEWAY 4) CONDITIONS INTERSECTION  
OPERATIONS ANALYSIS WORKSHEETS**



This Page Intentionally Left Blank

Intersection						
Int Delay, s/veh	0.3					
Movement	EBT	EBR	WBL	WBT	NBL	NBR
Lane Configurations	↑↑		↑	↑↑	↑	
Traffic Vol, veh/h	142	1	5	156	2	3
Future Vol, veh/h	142	1	5	156	2	3
Conflicting Peds, #/hr	0	0	0	0	0	0
Sign Control	Free	Free	Free	Free	Stop	Stop
RT Channelized	-	None	-	None	-	None
Storage Length	-	-	100	-	0	-
Veh in Median Storage, #	0	-	-	0	0	-
Grade, %	0	-	-	0	0	-
Peak Hour Factor	92	92	92	92	92	92
Heavy Vehicles, %	0	0	0	0	0	0
Mvmt Flow	154	1	5	170	2	3

Major/Minor	Major1	Major2	Minor1		
Conflicting Flow All	0	0	155	0	250 78
Stage 1	-	-	-	-	155 -
Stage 2	-	-	-	-	95 -
Critical Hdwy	-	-	4.1	-	6.8 6.9
Critical Hdwy Stg 1	-	-	-	-	5.8 -
Critical Hdwy Stg 2	-	-	-	-	5.8 -
Follow-up Hdwy	-	-	2.2	-	3.5 3.3
Pot Cap-1 Maneuver	-	-	1438	-	723 973
Stage 1	-	-	-	-	863 -
Stage 2	-	-	-	-	924 -
Platoon blocked, %	-	-	-	-	-
Mov Cap-1 Maneuver	-	-	1438	-	721 973
Mov Cap-2 Maneuver	-	-	-	-	721 -
Stage 1	-	-	-	-	863 -
Stage 2	-	-	-	-	921 -

Approach	EB	WB	NB
HCM Control Delay, s	0	0.2	9.2
HCM LOS			A

Minor Lane/Major Mvmt	NBLn1	EBT	EBR	WBL	WBT
Capacity (veh/h)	854	-	-	1438	-
HCM Lane V/C Ratio	0.006	-	-	0.004	-
HCM Control Delay (s)	9.2	-	-	7.5	-
HCM Lane LOS	A	-	-	A	-
HCM 95th %tile Q(veh)	0	-	-	0	-

Intersection						
Int Delay, s/veh	0.2					
Movement	EBT	EBR	WBL	WBT	NBL	NBR
Lane Configurations	↑↑			↑↑		↑
Traffic Vol, veh/h	144	1	0	161	0	7
Future Vol, veh/h	144	1	0	161	0	7
Conflicting Peds, #/hr	0	0	0	0	0	0
Sign Control	Free	Free	Free	Free	Stop	Stop
RT Channelized	-	None	-	None	-	None
Storage Length	-	-	-	-	-	0
Veh in Median Storage, #	0	-	-	0	0	-
Grade, %	0	-	-	0	0	-
Peak Hour Factor	92	92	92	92	92	92
Heavy Vehicles, %	0	0	0	0	0	0
Mvmt Flow	157	1	0	175	0	8

Major/Minor	Major1	Major2	Minor1		
Conflicting Flow All	0	0	-	-	79
Stage 1	-	-	-	-	-
Stage 2	-	-	-	-	-
Critical Hdwy	-	-	-	-	6.9
Critical Hdwy Stg 1	-	-	-	-	-
Critical Hdwy Stg 2	-	-	-	-	-
Follow-up Hdwy	-	-	-	-	3.3
Pot Cap-1 Maneuver	-	-	0	-	972
Stage 1	-	-	0	-	-
Stage 2	-	-	0	-	-
Platoon blocked, %	-	-	-	-	-
Mov Cap-1 Maneuver	-	-	-	-	972
Mov Cap-2 Maneuver	-	-	-	-	-
Stage 1	-	-	-	-	-
Stage 2	-	-	-	-	-

Approach	EB	WB	NB
HCM Control Delay, s	0	0	8.7
HCM LOS			A

Minor Lane/Major Mvmt	NBLn1	EBT	EBR	WBT
Capacity (veh/h)	972	-	-	-
HCM Lane V/C Ratio	0.008	-	-	-
HCM Control Delay (s)	8.7	-	-	-
HCM Lane LOS	A	-	-	-
HCM 95th %tile Q(veh)	0	-	-	-

Intersection						
Int Delay, s/veh	31.7					
Movement	EBL	EBR	NBL	NBT	SBT	SBR
Lane Configurations	Y		Y	↑	↑	
Traffic Vol, veh/h	135	91	150	1334	504	124
Future Vol, veh/h	135	91	150	1334	504	124
Conflicting Peds, #/hr	0	0	0	0	0	0
Sign Control	Stop	Stop	Free	Free	Free	Free
RT Channelized	-	None	-	None	-	None
Storage Length	0	-	200	-	-	-
Veh in Median Storage, #	2	-	-	0	0	-
Grade, %	0	-	-	0	0	-
Peak Hour Factor	86	86	86	86	86	86
Heavy Vehicles, %	0	0	0	0	0	0
Mvmt Flow	157	106	174	1551	586	144

Major/Minor	Minor2	Major1	Major2			
Conflicting Flow All	2557	658	730	0	-	0
Stage 1	658	-	-	-	-	-
Stage 2	1899	-	-	-	-	-
Critical Hdwy	6.4	6.2	4.1	-	-	-
Critical Hdwy Stg 1	5.4	-	-	-	-	-
Critical Hdwy Stg 2	5.4	-	-	-	-	-
Follow-up Hdwy	3.5	3.3	2.2	-	-	-
Pot Cap-1 Maneuver	~ 30	468	883	-	-	-
Stage 1	519	-	-	-	-	-
Stage 2	~ 131	-	-	-	-	-
Platoon blocked, %				-	-	-
Mov Cap-1 Maneuver	~ 24	468	883	-	-	-
Mov Cap-2 Maneuver	~ 119	-	-	-	-	-
Stage 1	417	-	-	-	-	-
Stage 2	~ 131	-	-	-	-	-

Approach	EB	NB	SB
HCM Control Delay, s	321.7	1	0
HCM LOS	F		

Minor Lane/Major Mvmt	NBL	NBT	EBLn1	SBT	SBR
Capacity (veh/h)	883	-	170	-	-
HCM Lane V/C Ratio	0.198	-	1.546	-	-
HCM Control Delay (s)	10.1	-	321.7	-	-
HCM Lane LOS	B	-	F	-	-
HCM 95th %tile Q(veh)	0.7	-	17.3	-	-

Notes  
 ~: Volume exceeds capacity    \$: Delay exceeds 300s    +: Computation Not Defined    \*: All major volume in platoon

Timings  
4: Temescal Canyon Rd & Trilogy Pkwy



Lane Group	EBL	EBR	NBL	NBT	SBT	SBR
Lane Configurations	↖	↗	↖	↑	↑	↗
Traffic Volume (vph)	86	65	80	1398	515	81
Future Volume (vph)	86	65	80	1398	515	81
Turn Type	Prot	Perm	Prot	NA	NA	Perm
Protected Phases	4		5	2	6	
Permitted Phases		4				6
Detector Phase	4	4	5	2	6	6
Switch Phase						
Minimum Initial (s)	10.0	10.0	5.0	10.0	10.0	10.0
Minimum Split (s)	28.8	28.8	9.6	15.4	33.4	33.4
Total Split (s)	28.8	28.8	10.0	61.2	51.2	51.2
Total Split (%)	32.0%	32.0%	11.1%	68.0%	56.9%	56.9%
Yellow Time (s)	4.8	4.8	3.6	4.4	4.4	4.4
All-Red Time (s)	1.0	1.0	1.0	1.0	1.0	1.0
Lost Time Adjust (s)	-1.8	-1.8	-0.6	-1.4	-1.4	-1.4
Total Lost Time (s)	4.0	4.0	4.0	4.0	4.0	4.0
Lead/Lag			Lead		Lag	Lag
Lead-Lag Optimize?			Yes		Yes	Yes
Recall Mode	None	None	None	None	None	None
Act Effct Green (s)	14.3	14.3	6.0	59.1	51.4	51.4
Actuated g/C Ratio	0.19	0.19	0.08	0.77	0.67	0.67
v/c Ratio	0.26	0.19	0.58	0.97	0.41	0.07
Control Delay	29.8	8.6	55.0	32.1	10.4	3.2
Queue Delay	0.0	0.0	0.0	0.0	0.0	0.0
Total Delay	29.8	8.6	55.0	32.1	10.4	3.2
LOS	C	A	D	C	B	A
Approach Delay	20.7			33.3	9.4	
Approach LOS	C			C	A	

Intersection Summary

Cycle Length: 90  
 Actuated Cycle Length: 76.5  
 Natural Cycle: 120  
 Control Type: Actuated-Uncoordinated  
 Maximum v/c Ratio: 0.97  
 Intersection Signal Delay: 26.0  
 Intersection LOS: C  
 Intersection Capacity Utilization 88.6%  
 ICU Level of Service E  
 Analysis Period (min) 15

Splits and Phases: 4: Temescal Canyon Rd & Trilogy Pkwy

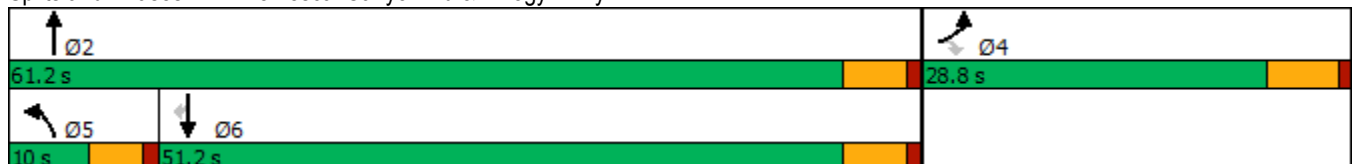



HCM 6th Signalized Intersection Summary  
4: Temescal Canyon Rd & Trilogy Pkwy

Glen Ivy Senior Living (JN 13030)  
09/11/2020



Movement	EBL	EBR	NBL	NBT	SBT	SBR
Lane Configurations						
Traffic Volume (veh/h)	86	65	80	1398	515	81
Future Volume (veh/h)	86	65	80	1398	515	81
Initial Q (Qb), veh	0	0	0	0	0	0
Ped-Bike Adj(A_pbT)	1.00	1.00	1.00			1.00
Parking Bus, Adj	1.00	1.00	1.00	1.00	1.00	1.00
Work Zone On Approach	No			No	No	
Adj Sat Flow, veh/h/ln	1900	1900	1900	1900	1900	1900
Adj Flow Rate, veh/h	88	54	82	1427	526	81
Peak Hour Factor	0.98	0.98	0.98	0.98	0.98	0.98
Percent Heavy Veh, %	0	0	0	0	0	0
Cap, veh/h	268	238	119	1420	1196	1013
Arrive On Green	0.15	0.15	0.07	0.75	0.63	0.63
Sat Flow, veh/h	1810	1610	1810	1900	1900	1610
Grp Volume(v), veh/h	88	54	82	1427	526	81
Grp Sat Flow(s),veh/h/ln	1810	1610	1810	1900	1900	1610
Q Serve(g_s), s	3.3	2.3	3.4	57.2	10.9	1.5
Cycle Q Clear(g_c), s	3.3	2.3	3.4	57.2	10.9	1.5
Prop In Lane	1.00	1.00	1.00			1.00
Lane Grp Cap(c), veh/h	268	238	119	1420	1196	1013
V/C Ratio(X)	0.33	0.23	0.69	1.00	0.44	0.08
Avail Cap(c_a), veh/h	587	522	142	1420	1196	1013
HCM Platoon Ratio	1.00	1.00	1.00	1.00	1.00	1.00
Upstream Filter(I)	1.00	1.00	1.00	1.00	1.00	1.00
Uniform Delay (d), s/veh	29.2	28.7	35.0	9.7	7.3	5.5
Incr Delay (d2), s/veh	0.7	0.5	7.0	25.0	0.3	0.0
Initial Q Delay(d3),s/veh	0.0	0.0	0.0	0.0	0.0	0.0
%ile BackOfQ(50%),veh/ln	1.4	0.0	1.7	21.4	3.4	0.4
Unsig. Movement Delay, s/veh						
LnGrp Delay(d),s/veh	29.9	29.2	42.0	34.7	7.5	5.6
LnGrp LOS	C	C	D	F	A	A
Approach Vol, veh/h	142			1509	607	
Approach Delay, s/veh	29.6			35.0	7.3	
Approach LOS	C			D	A	
Timer - Assigned Phs		2		4	5	6
Phs Duration (G+Y+Rc), s		61.2		15.3	9.0	52.2
Change Period (Y+Rc), s		5.4		5.8	4.6	5.4
Max Green Setting (Gmax), s		55.8		23.0	5.4	45.8
Max Q Clear Time (g_c+11), s		59.2		5.3	5.4	12.9
Green Ext Time (p_c), s		0.0		0.3	0.0	3.7
<b>Intersection Summary</b>						
HCM 6th Ctrl Delay			27.2			
HCM 6th LOS			C			

Intersection						
Int Delay, s/veh	0					
Movement	EBL	EBR	NBL	NBT	SBT	SBR
Lane Configurations		↗		↑	↘	
Traffic Vol, veh/h	0	1	0	1477	570	10
Future Vol, veh/h	0	1	0	1477	570	10
Conflicting Peds, #/hr	0	0	0	0	0	0
Sign Control	Stop	Stop	Free	Free	Free	Free
RT Channelized	-	None	-	None	-	None
Storage Length	-	0	-	-	-	-
Veh in Median Storage, #	0	-	-	0	0	-
Grade, %	0	-	-	0	0	-
Peak Hour Factor	92	92	92	92	92	92
Heavy Vehicles, %	0	0	0	0	0	0
Mvmt Flow	0	1	0	1605	620	11

Major/Minor	Minor2	Major1	Major2		
Conflicting Flow All	-	626	-	0	0
Stage 1	-	-	-	-	-
Stage 2	-	-	-	-	-
Critical Hdwy	-	6.2	-	-	-
Critical Hdwy Stg 1	-	-	-	-	-
Critical Hdwy Stg 2	-	-	-	-	-
Follow-up Hdwy	-	3.3	-	-	-
Pot Cap-1 Maneuver	0	488	0	-	-
Stage 1	0	-	0	-	-
Stage 2	0	-	0	-	-
Platoon blocked, %				-	-
Mov Cap-1 Maneuver	-	488	-	-	-
Mov Cap-2 Maneuver	-	-	-	-	-
Stage 1	-	-	-	-	-
Stage 2	-	-	-	-	-

Approach	EB	NB	SB
HCM Control Delay, s	12.4	0	0
HCM LOS	B		

Minor Lane/Major Mvmt	NBT EBLn1	SBT	SBR
Capacity (veh/h)	- 488	-	-
HCM Lane V/C Ratio	- 0.002	-	-
HCM Control Delay (s)	- 12.4	-	-
HCM Lane LOS	- B	-	-
HCM 95th %tile Q(veh)	- 0	-	-

Intersection						
Int Delay, s/veh	0.2					
Movement	EBL	EBR	NBL	NBT	SBT	SBR
Lane Configurations	Y		Y	↑	↑	
Traffic Vol, veh/h	5	3	4	1473	568	4
Future Vol, veh/h	5	3	4	1473	568	4
Conflicting Peds, #/hr	0	0	0	0	0	0
Sign Control	Stop	Stop	Free	Free	Free	Free
RT Channelized	-	None	-	None	-	None
Storage Length	0	-	100	-	-	-
Veh in Median Storage, #	0	-	-	0	0	-
Grade, %	0	-	-	0	0	-
Peak Hour Factor	92	92	92	92	92	92
Heavy Vehicles, %	0	0	0	0	0	0
Mvmt Flow	5	3	4	1601	617	4

Major/Minor	Minor2	Major1	Major2			
Conflicting Flow All	2228	619	621	0	-	0
Stage 1	619	-	-	-	-	-
Stage 2	1609	-	-	-	-	-
Critical Hdwy	6.4	6.2	4.1	-	-	-
Critical Hdwy Stg 1	5.4	-	-	-	-	-
Critical Hdwy Stg 2	5.4	-	-	-	-	-
Follow-up Hdwy	3.5	3.3	2.2	-	-	-
Pot Cap-1 Maneuver	48	492	969	-	-	-
Stage 1	541	-	-	-	-	-
Stage 2	182	-	-	-	-	-
Platoon blocked, %				-	-	-
Mov Cap-1 Maneuver	48	492	969	-	-	-
Mov Cap-2 Maneuver	48	-	-	-	-	-
Stage 1	539	-	-	-	-	-
Stage 2	182	-	-	-	-	-

Approach	EB	NB	SB
HCM Control Delay, s	60.9	0	0
HCM LOS	F		

Minor Lane/Major Mvmt	NBL	NBT	EBLn1	SBT	SBR
Capacity (veh/h)	969	-	73	-	-
HCM Lane V/C Ratio	0.004	-	0.119	-	-
HCM Control Delay (s)	8.7	-	60.9	-	-
HCM Lane LOS	A	-	F	-	-
HCM 95th %tile Q(veh)	0	-	0.4	-	-

Intersection						
Int Delay, s/veh	0.3					
Movement	EBT	EBR	WBL	WBT	NBL	NBR
Lane Configurations	↑↑		↑	↑↑	↑	
Traffic Vol, veh/h	285	1	5	215	4	5
Future Vol, veh/h	285	1	5	215	4	5
Conflicting Peds, #/hr	0	0	0	0	0	0
Sign Control	Free	Free	Free	Free	Stop	Stop
RT Channelized	-	None	-	None	-	None
Storage Length	-	-	100	-	0	-
Veh in Median Storage, #	0	-	-	0	0	-
Grade, %	0	-	-	0	0	-
Peak Hour Factor	92	92	92	92	92	92
Heavy Vehicles, %	0	0	0	0	0	0
Mvmt Flow	310	1	5	234	4	5

Major/Minor	Major1	Major2	Minor1			
Conflicting Flow All	0	0	311	0	438	156
Stage 1	-	-	-	-	311	-
Stage 2	-	-	-	-	127	-
Critical Hdwy	-	-	4.1	-	6.8	6.9
Critical Hdwy Stg 1	-	-	-	-	5.8	-
Critical Hdwy Stg 2	-	-	-	-	5.8	-
Follow-up Hdwy	-	-	2.2	-	3.5	3.3
Pot Cap-1 Maneuver	-	-	1261	-	552	868
Stage 1	-	-	-	-	722	-
Stage 2	-	-	-	-	891	-
Platoon blocked, %	-	-	-	-	-	-
Mov Cap-1 Maneuver	-	-	1261	-	550	868
Mov Cap-2 Maneuver	-	-	-	-	550	-
Stage 1	-	-	-	-	722	-
Stage 2	-	-	-	-	887	-

Approach	EB	WB	NB
HCM Control Delay, s	0	0.2	10.3
HCM LOS			B

Minor Lane/Major Mvmt	NBLn1	EBT	EBR	WBL	WBT
Capacity (veh/h)	691	-	-	1261	-
HCM Lane V/C Ratio	0.014	-	-	0.004	-
HCM Control Delay (s)	10.3	-	-	7.9	-
HCM Lane LOS	B	-	-	A	-
HCM 95th %tile Q(veh)	0	-	-	0	-

Intersection						
Int Delay, s/veh	0.2					
Movement	EBT	EBR	WBL	WBT	NBL	NBR
Lane Configurations	↑↑			↑↑		↑
Traffic Vol, veh/h	289	1	0	220	0	13
Future Vol, veh/h	289	1	0	220	0	13
Conflicting Peds, #/hr	0	0	0	0	0	0
Sign Control	Free	Free	Free	Free	Stop	Stop
RT Channelized	-	None	-	None	-	None
Storage Length	-	-	-	-	-	0
Veh in Median Storage, #	0	-	-	0	0	-
Grade, %	0	-	-	0	0	-
Peak Hour Factor	92	92	92	92	92	92
Heavy Vehicles, %	0	0	0	0	0	0
Mvmt Flow	314	1	0	239	0	14

Major/Minor	Major1	Major2	Minor1	Minor2	Minor3
Conflicting Flow All	0	0	-	-	158
Stage 1	-	-	-	-	-
Stage 2	-	-	-	-	-
Critical Hdwy	-	-	-	-	6.9
Critical Hdwy Stg 1	-	-	-	-	-
Critical Hdwy Stg 2	-	-	-	-	-
Follow-up Hdwy	-	-	-	-	3.3
Pot Cap-1 Maneuver	-	-	0	-	866
Stage 1	-	-	0	-	-
Stage 2	-	-	0	-	-
Platoon blocked, %	-	-	-	-	-
Mov Cap-1 Maneuver	-	-	-	-	866
Mov Cap-2 Maneuver	-	-	-	-	-
Stage 1	-	-	-	-	-
Stage 2	-	-	-	-	-

Approach	EB	WB	NB
HCM Control Delay, s	0	0	9.2
HCM LOS			A

Minor Lane/Major Mvmt	NBLn1	EBT	EBR	WBT
Capacity (veh/h)	866	-	-	-
HCM Lane V/C Ratio	0.016	-	-	-
HCM Control Delay (s)	9.2	-	-	-
HCM Lane LOS	A	-	-	-
HCM 95th %tile Q(veh)	0.1	-	-	-



Intersection						
Int Delay, s/veh	70.4					
Movement	EBL	EBR	NBL	NBT	SBT	SBR
Lane Configurations	↔		↔	↑	↑	
Traffic Vol, veh/h	280	106	127	639	807	312
Future Vol, veh/h	280	106	127	639	807	312
Conflicting Peds, #/hr	0	0	0	0	0	0
Sign Control	Stop	Stop	Free	Free	Free	Free
RT Channelized	-	None	-	None	-	None
Storage Length	0	-	200	-	-	-
Veh in Median Storage, #	2	-	-	0	0	-
Grade, %	0	-	-	0	0	-
Peak Hour Factor	94	94	94	94	94	94
Heavy Vehicles, %	0	0	0	0	0	0
Mvmt Flow	298	113	135	680	859	332

Major/Minor	Minor2	Major1		Major2	
Conflicting Flow All	1975	1025	1191	0	0
Stage 1	1025	-	-	-	-
Stage 2	950	-	-	-	-
Critical Hdwy	6.4	6.2	4.1	-	-
Critical Hdwy Stg 1	5.4	-	-	-	-
Critical Hdwy Stg 2	5.4	-	-	-	-
Follow-up Hdwy	3.5	3.3	2.2	-	-
Pot Cap-1 Maneuver	~ 69	288	593	-	-
Stage 1	349	-	-	-	-
Stage 2	379	-	-	-	-
Platoon blocked, %				-	-
Mov Cap-1 Maneuver	~ 53	288	593	-	-
Mov Cap-2 Maneuver	~ 212	-	-	-	-
Stage 1	~ 269	-	-	-	-
Stage 2	379	-	-	-	-

Approach	EB	NB	SB
HCM Control Delay, s	\$ 410.2	2.1	0
HCM LOS	F		

Minor Lane/Major Mvmt	NBL	NBT	EBLn1	SBT	SBR
Capacity (veh/h)	593	-	229	-	-
HCM Lane V/C Ratio	0.228	-	1.793	-	-
HCM Control Delay (s)	12.9	-	\$ 410.2	-	-
HCM Lane LOS	B	-	F	-	-
HCM 95th %tile Q(veh)	0.9	-	28.2	-	-

Notes  
 ~: Volume exceeds capacity    \$: Delay exceeds 300s    +: Computation Not Defined    \*: All major volume in platoon

Timings  
4: Temescal Canyon Rd & Trilogy Pkwy



Lane Group	EBL	EBR	NBL	NBT	SBT	SBR
Lane Configurations	↖	↗	↖	↑	↑	↗
Traffic Volume (vph)	210	91	91	555	783	130
Future Volume (vph)	210	91	91	555	783	130
Turn Type	Prot	Perm	Prot	NA	NA	Perm
Protected Phases	4		5	2	6	
Permitted Phases		4				6
Detector Phase	4	4	5	2	6	6
Switch Phase						
Minimum Initial (s)	10.0	10.0	5.0	10.0	10.0	10.0
Minimum Split (s)	28.8	28.8	9.6	15.4	33.4	33.4
Total Split (s)	31.0	31.0	11.0	59.0	48.0	48.0
Total Split (%)	34.4%	34.4%	12.2%	65.6%	53.3%	53.3%
Yellow Time (s)	4.8	4.8	3.6	4.4	4.4	4.4
All-Red Time (s)	1.0	1.0	1.0	1.0	1.0	1.0
Lost Time Adjust (s)	-1.8	-1.8	-0.6	-1.4	-1.4	-1.4
Total Lost Time (s)	4.0	4.0	4.0	4.0	4.0	4.0
Lead/Lag			Lead		Lag	Lag
Lead-Lag Optimize?			Yes		Yes	Yes
Recall Mode	None	None	None	None	None	None
Act Effct Green (s)	17.4	17.4	7.2	45.0	37.0	37.0
Actuated g/C Ratio	0.24	0.24	0.10	0.63	0.52	0.52
v/c Ratio	0.50	0.20	0.52	0.48	0.83	0.16
Control Delay	30.4	7.0	48.2	8.4	24.5	6.2
Queue Delay	0.0	0.0	0.0	0.0	0.0	0.0
Total Delay	30.4	7.0	48.2	8.4	24.5	6.2
LOS	C	A	D	A	C	A
Approach Delay	23.3			14.1	21.9	
Approach LOS	C			B	C	

Intersection Summary

Cycle Length: 90  
 Actuated Cycle Length: 71.1  
 Natural Cycle: 80  
 Control Type: Actuated-Uncoordinated  
 Maximum v/c Ratio: 0.83  
 Intersection Signal Delay: 19.4  
 Intersection LOS: B  
 Intersection Capacity Utilization 67.9%  
 ICU Level of Service C  
 Analysis Period (min) 15

Splits and Phases: 4: Temescal Canyon Rd & Trilogy Pkwy

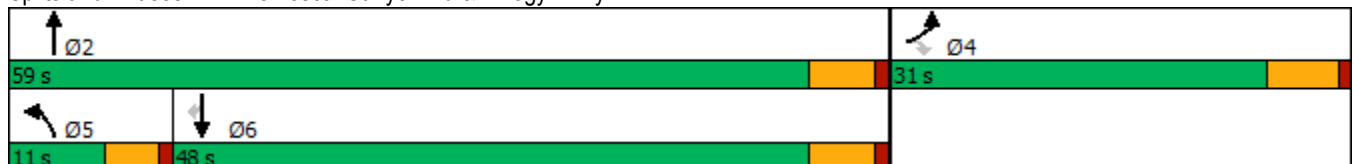

HCM 6th Signalized Intersection Summary  
4: Temescal Canyon Rd & Trilogy Pkwy

Glen Ivy Senior Living (JN 13030)  
09/11/2020



Movement	EBL	EBR	NBL	NBT	SBT	SBR
Lane Configurations						
Traffic Volume (veh/h)	210	91	91	555	783	130
Future Volume (veh/h)	210	91	91	555	783	130
Initial Q (Qb), veh	0	0	0	0	0	0
Ped-Bike Adj(A_pbT)	1.00	1.00	1.00			0.98
Parking Bus, Adj	1.00	1.00	1.00	1.00	1.00	1.00
Work Zone On Approach	No			No	No	
Adj Sat Flow, veh/h/ln	1900	1900	1900	1900	1900	1900
Adj Flow Rate, veh/h	219	79	95	578	816	123
Peak Hour Factor	0.96	0.96	0.96	0.96	0.96	0.96
Percent Heavy Veh, %	0	0	0	0	0	0
Cap, veh/h	360	320	140	1264	988	820
Arrive On Green	0.20	0.20	0.08	0.67	0.52	0.52
Sat Flow, veh/h	1810	1610	1810	1900	1900	1577
Grp Volume(v), veh/h	219	79	95	578	816	123
Grp Sat Flow(s),veh/h/ln	1810	1610	1810	1900	1900	1577
Q Serve(g_s), s	6.5	2.4	3.0	8.6	21.3	2.4
Cycle Q Clear(g_c), s	6.5	2.4	3.0	8.6	21.3	2.4
Prop In Lane	1.00	1.00	1.00			1.00
Lane Grp Cap(c), veh/h	360	320	140	1264	988	820
V/C Ratio(X)	0.61	0.25	0.68	0.46	0.83	0.15
Avail Cap(c_a), veh/h	829	738	215	1773	1418	1177
HCM Platoon Ratio	1.00	1.00	1.00	1.00	1.00	1.00
Upstream Filter(I)	1.00	1.00	1.00	1.00	1.00	1.00
Uniform Delay (d), s/veh	21.5	19.9	26.5	4.7	11.9	7.4
Incr Delay (d2), s/veh	1.7	0.4	2.1	0.3	2.8	0.1
Initial Q Delay(d3),s/veh	0.0	0.0	0.0	0.0	0.0	0.0
%ile BackOfQ(50%),veh/ln	2.5	0.0	1.3	1.9	7.2	0.6
Unsig. Movement Delay, s/veh						
LnGrp Delay(d),s/veh	23.2	20.3	28.6	5.0	14.7	7.4
LnGrp LOS	C	C	C	A	B	A
Approach Vol, veh/h	298			673	939	
Approach Delay, s/veh	22.4			8.3	13.7	
Approach LOS	C			A	B	
Timer - Assigned Phs		2		4	5	6
Phs Duration (G+Y+Rc), s		43.2		15.7	8.6	34.7
Change Period (Y+Rc), s		5.4		5.8	4.6	5.4
Max Green Setting (Gmax), s		53.6		25.2	6.4	42.6
Max Q Clear Time (g_c+11), s		10.6		8.5	5.0	23.3
Green Ext Time (p_c), s		4.0		0.8	0.0	6.0
<b>Intersection Summary</b>						
HCM 6th Ctrl Delay			13.2			
HCM 6th LOS			B			

Intersection						
Int Delay, s/veh	0					
Movement	EBL	EBR	NBL	NBT	SBT	SBR
Lane Configurations		↗		↑	↘	
Traffic Vol, veh/h	0	3	0	646	863	11
Future Vol, veh/h	0	3	0	646	863	11
Conflicting Peds, #/hr	0	0	0	0	0	0
Sign Control	Stop	Stop	Free	Free	Free	Free
RT Channelized	-	None	-	None	-	None
Storage Length	-	0	-	-	-	-
Veh in Median Storage, #	0	-	-	0	0	-
Grade, %	0	-	-	0	0	-
Peak Hour Factor	92	92	92	92	92	92
Heavy Vehicles, %	0	0	0	0	0	0
Mvmt Flow	0	3	0	702	938	12

Major/Minor	Minor2	Major1	Major2		
Conflicting Flow All	-	944	-	0	-
Stage 1	-	-	-	-	-
Stage 2	-	-	-	-	-
Critical Hdwy	-	6.2	-	-	-
Critical Hdwy Stg 1	-	-	-	-	-
Critical Hdwy Stg 2	-	-	-	-	-
Follow-up Hdwy	-	3.3	-	-	-
Pot Cap-1 Maneuver	0	321	0	-	-
Stage 1	0	-	0	-	-
Stage 2	0	-	0	-	-
Platoon blocked, %				-	-
Mov Cap-1 Maneuver	-	321	-	-	-
Mov Cap-2 Maneuver	-	-	-	-	-
Stage 1	-	-	-	-	-
Stage 2	-	-	-	-	-

Approach	EB	NB	SB
HCM Control Delay, s	16.3	0	0
HCM LOS	C		

Minor Lane/Major Mvmt	NBT	EBLn1	SBT	SBR
Capacity (veh/h)	-	321	-	-
HCM Lane V/C Ratio	-	0.01	-	-
HCM Control Delay (s)	-	16.3	-	-
HCM Lane LOS	-	C	-	-
HCM 95th %tile Q(veh)	-	0	-	-

Intersection						
Int Delay, s/veh	0.3					
Movement	EBL	EBR	NBL	NBT	SBT	SBR
Lane Configurations	Y		Y	↑	↑	
Traffic Vol, veh/h	8	5	4	638	861	4
Future Vol, veh/h	8	5	4	638	861	4
Conflicting Peds, #/hr	0	0	0	0	0	0
Sign Control	Stop	Stop	Free	Free	Free	Free
RT Channelized	-	None	-	None	-	None
Storage Length	0	-	100	-	-	-
Veh in Median Storage, #	0	-	-	0	0	-
Grade, %	0	-	-	0	0	-
Peak Hour Factor	92	92	92	92	92	92
Heavy Vehicles, %	0	0	0	0	0	0
Mvmt Flow	9	5	4	693	936	4

Major/Minor	Minor2	Major1	Major2			
Conflicting Flow All	1639	938	940	0	-	0
Stage 1	938	-	-	-	-	-
Stage 2	701	-	-	-	-	-
Critical Hdwy	6.4	6.2	4.1	-	-	-
Critical Hdwy Stg 1	5.4	-	-	-	-	-
Critical Hdwy Stg 2	5.4	-	-	-	-	-
Follow-up Hdwy	3.5	3.3	2.2	-	-	-
Pot Cap-1 Maneuver	112	323	737	-	-	-
Stage 1	384	-	-	-	-	-
Stage 2	496	-	-	-	-	-
Platoon blocked, %				-	-	-
Mov Cap-1 Maneuver	111	323	737	-	-	-
Mov Cap-2 Maneuver	111	-	-	-	-	-
Stage 1	382	-	-	-	-	-
Stage 2	496	-	-	-	-	-

Approach	EB	NB	SB
HCM Control Delay, s	31.9	0.1	0
HCM LOS	D		

Minor Lane/Major Mvmt	NBL	NBT	EBLn1	SBT	SBR
Capacity (veh/h)	737	-	148	-	-
HCM Lane V/C Ratio	0.006	-	0.095	-	-
HCM Control Delay (s)	9.9	-	31.9	-	-
HCM Lane LOS	A	-	D	-	-
HCM 95th %tile Q(veh)	0	-	0.3	-	-



**APPENDIX 6.3:**

**EAPC (2023) CONDITIONS TRAFFIC SIGNAL WARRANT ANALYSIS WORKSHEETS**

This Page Intentionally Left Blank

### Figure 4C-4. Warrant 3, Peak Hour (70% Factor)

(COMMUNITY LESS THAN 10,000 POPULATION OR ABOVE 64 km/h OR ABOVE 40 mph ON MAJOR STREET)

Traffic Conditions = **EAPC (2023) Conditions - Weekday AM Peak Hour**

Major Street Name = **Temescal Canyon Rd.** Total of Both Approaches (VPH) = **2112**  
 Number of Approach Lanes Major Street = **1**

Minor Street Name = **Lawson Rd.** High Volume Approach (VPH) = **225**  
 Number of Approach Lanes Minor Street = **1**

**WARRANTED FOR A SIGNAL**

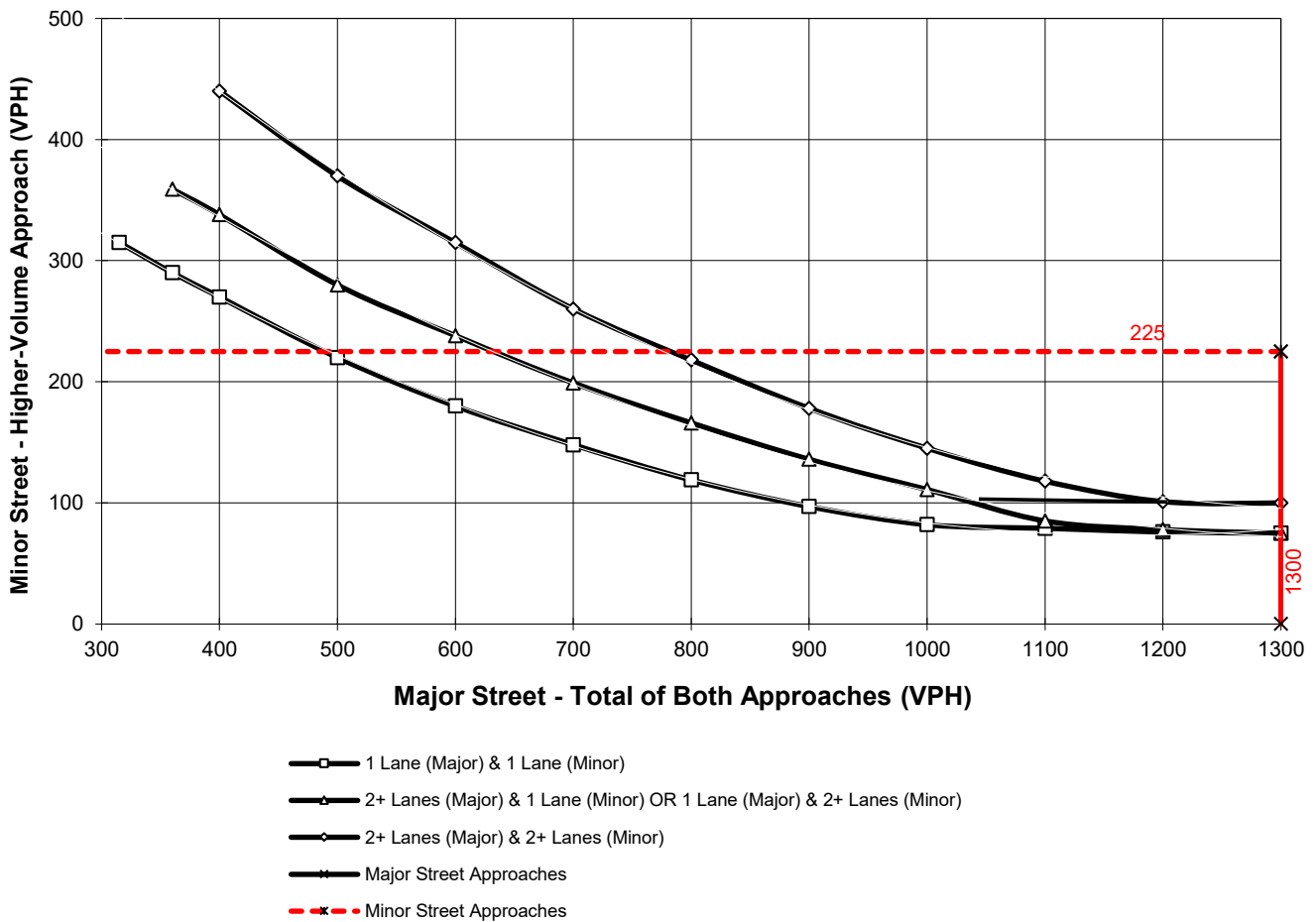

\*Note: 100 vph applies as the lower threshold for a minor-street approach with two or more lanes and 75 vph applies as the lower threshold for a minor-street approach with one lane

### Figure 4C-103 (CA). Traffic Signal Warrants Worksheet (Average Traffic Estimate Form)

<u>DIST</u>	<u>CO</u>	<u>RTE</u>	<u>PM</u>	TRAFFIC CONDITIONS	<b>EAPC 2023</b>
Jurisdiction: <u>County of Riverside</u>				CALC <u>CS</u>	DATE <u>09/03/20</u>
Major Street: <u>Trilogy Pkwy.</u>				CHK <u>CS</u>	DATE <u>09/03/20</u>
Minor Street: <u>Driveway 1</u>				Critical Approach Speed (Major) <u>45</u> mph	
				Critical Approach Speed (Minor) <u>25</u> mph	
Major Street Approach Lanes = <u>1</u>	lane	Minor Street Approach Lanes = <u>1</u>	lane		
Major Street Future ADT = <u>7,082</u>	vpd	Minor Street Future ADT = <u>134</u>	vpd		
Speed limit or critical speed on major street traffic > 64 km/h (40 mph); .....	<input checked="" type="checkbox"/>	or	<input type="checkbox"/>		<b>RURAL (R)</b>
In built up area of isolated community of < 10,000 population .....	<input type="checkbox"/>				

**(Based on Estimated Average Daily Traffic - See Note)**

<u>URBAN</u>	<u>RURAL</u>	Minimum Requirements EADT			
<b>CONDITION A - Minimum Vehicular Volume</b>	<b>XX</b>	Vehicles Per Day on Major Street (Total of Both Approaches)		Vehicles Per Day on Higher-Volume Minor Street Approach (One Direction Only)	
<u>Satisfied</u>	<u>Not Satisfied</u>				
	<b>XX</b>	<u>Urban</u>	<u>Rural</u>	<u>Urban</u>	<u>Rural</u>
Number of lanes for moving traffic on each approach					
<u>Major Street</u>	<u>Minor Street</u>				
<u>1 7,082</u>	<u>1 134</u>	8,000	5,600 *	2,400	1,680
2 +	1	9,600	6,720	2,400	1,680
2 +	2 +	9,600	6,720	3,200	2,240
1	2 +	8,000	5,600	3,200	2,240
<b>CONDITION B - Interruption of Continuous Traffic</b>		Vehicles Per Day on Major Street (Total of Both Approaches)		Vehicles Per Day on Higher-Volume Minor Street Approach (One Direction Only)	
<u>Satisfied</u>	<u>Not Satisfied</u>				
	<b>XX</b>	<u>Urban</u>	<u>Rural</u>	<u>Urban</u>	<u>Rural</u>
Number of lanes for moving traffic on each approach					
<u>Major Street</u>	<u>Minor Street</u>				
<u>1 7,082</u>	<u>1 134</u>	12,000	8,400	1,200	850
2 +	1	14,400	10,080	1,200	850
2 +	2 +	14,400	10,080	1,600	1,120
1	2 +	12,000	8,400	1,600	1,120
<b>Combination of CONDITIONS A + B</b>		2 CONDITIONS		2 CONDITIONS	
<u>Satisfied</u>	<u>Not Satisfied</u>	80%		80%	
No one condition satisfied, but following conditions fulfilled 80% of more .....	<b>XX</b>				
	<b>A</b>				
	<b>8%</b>				
	<b>B</b>				
	<b>16%</b>				

**Note: To be used only for NEW INTERSECTIONS or other locations where it is not reasonable to count actual traffic volumes.**

The satisfaction of a traffic signal warrant or warrants shall not in itself require the installation of a traffic control signal.



### Figure 4C-103 (CA). Traffic Signal Warrants Worksheet (Average Traffic Estimate Form)

<u>DIST</u>	<u>CO</u>	<u>RTE</u>	<u>PM</u>	TRAFFIC CONDITIONS	<u>EAPC 2023</u>
Jurisdiction: <u>County of Riverside</u>				CALC <u>CS</u>	DATE <u>09/03/20</u>
Major Street: <u>Temescal Canyon Rd.</u>				CHK <u>CS</u>	DATE <u>09/03/20</u>
Minor Street: <u>Driveway 4</u>				Critical Approach Speed (Major) <u>40</u> mph	
				Critical Approach Speed (Minor) <u>25</u> mph	

Major Street Approach Lanes = 1 lane                      Minor Street Approach Lanes: 1 lane

Major Street Future ADT = 32,051 vpd                      Minor Street Future ADT = 117 vpd

Speed limit or critical speed on major street traffic > 64 km/h (40 mph); .....

or

In built up area of isolated community of < 10,000 population .....  **RURAL (R)**

**(Based on Estimated Average Daily Traffic - See Note)**

<u>URBAN</u>	<u>RURAL</u>	Minimum Requirements EADT			
<b>XX</b>					
<b>CONDITION A - Minimum Vehicular Volume</b>		Vehicles Per Day on Major Street		Vehicles Per Day on Higher-Volume Minor Street Approach	
<u>Satisfied</u>	<u>Not Satisfied</u>	(Total of Both Approaches)		(One Direction Only)	
	<b>XX</b>	Urban	Rural	Urban	Rural
Number of lanes for moving traffic on each approach					
<u>Major Street</u>	<u>Minor Street</u>				
1 <b>32,051</b>	1 <b>117</b>	8,000 *	5,600	2,400	1,680
2 +	1	9,600	6,720	2,400	1,680
2 +	2 +	9,600	6,720	3,200	2,240
1	2 +	8,000	5,600	3,200	2,240
<b>CONDITION B - Interruption of Continuous Traffic</b>		Vehicles Per Day on Major Street		Vehicles Per Day on Higher-Volume Minor Street Approach	
<u>Satisfied</u>	<u>Not Satisfied</u>	(Total of Both Approaches)		(One Direction Only)	
	<b>XX</b>	Urban	Rural	Urban	Rural
Number of lanes for moving traffic on each approach					
<u>Major Street</u>	<u>Minor Street</u>				
1 <b>32,051</b>	1 <b>117</b>	12,000 *	8,400	1,200	850
2 +	1	14,400	10,080	1,200	850
2 +	2 +	14,400	10,080	1,600	1,120
1	2 +	12,000	8,400	1,600	1,120
<b>Combination of CONDITIONS A + B</b>		2 CONDITIONS		2 CONDITIONS	
<u>Satisfied</u>	<u>Not Satisfied</u>	80%		80%	
No one condition satisfied, but following conditions fulfilled 80% of more .....	<b>XX</b>				
	<b>A</b>				
	<b>5%</b>				
	<b>B</b>				
	<b>10%</b>				

**Note: To be used only for NEW INTERSECTIONS or other locations where it is not reasonable to count actual traffic volumes.**

The satisfaction of a traffic signal warrant or warrants shall not in itself require the installation of a traffic control signal.





This Page Intentionally Left Blank

**APPENDIX 6.4:**

**EAPC (2023) CONDITIONS INTERSECTION OPERATIONS ANALYSIS WORKSHEETS  
WITH IMPROVEMENTS**

This Page Intentionally Left Blank

Timings  
3: Temescal Canyon Rd & Lawson Rd.



Lane Group	EBL	NBL	NBT	SBT
Lane Configurations	W	W	↑↑	↑↑
Traffic Volume (vph)	135	150	1334	504
Future Volume (vph)	135	150	1334	504
Turn Type	Prot	Prot	NA	NA
Protected Phases	4	5	2	6
Permitted Phases				
Detector Phase	4	5	2	6
Switch Phase				
Minimum Initial (s)	10.0	5.0	10.0	10.0
Minimum Split (s)	28.8	9.6	15.4	33.4
Total Split (s)	30.0	22.0	60.0	38.0
Total Split (%)	33.3%	24.4%	66.7%	42.2%
Yellow Time (s)	4.8	3.6	4.4	4.4
All-Red Time (s)	1.0	1.0	1.0	1.0
Lost Time Adjust (s)	0.0	0.0	0.0	0.0
Total Lost Time (s)	5.8	4.6	5.4	5.4
Lead/Lag		Lead		Lag
Lead-Lag Optimize?		Yes		Yes
Recall Mode	None	None	None	None

Intersection Summary

Cycle Length: 90

Actuated Cycle Length: 64.7

Natural Cycle: 75

Control Type: Actuated-Uncoordinated

Splits and Phases: 3: Temescal Canyon Rd & Lawson Rd.

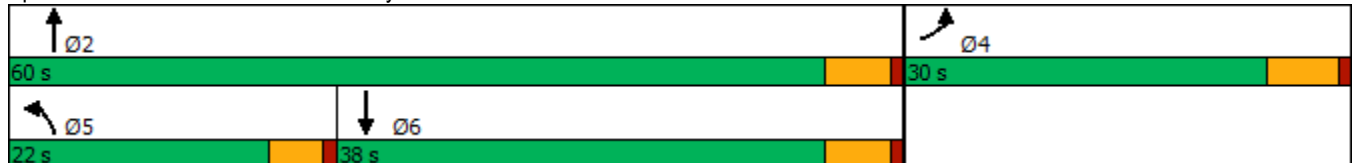

HCM 6th Signalized Intersection Summary  
 3: Temescal Canyon Rd & Lawson Rd.

Glen Ivy Senior Living (JN 13030)

09/11/2020



Movement	EBL	EBR	NBL	NBT	SBT	SBR
Lane Configurations						
Traffic Volume (veh/h)	135	91	150	1334	504	124
Future Volume (veh/h)	135	91	150	1334	504	124
Initial Q (Qb), veh	0	0	0	0	0	0
Ped-Bike Adj(A_pbT)	1.00	1.00	1.00			1.00
Parking Bus, Adj	1.00	1.00	1.00	1.00	1.00	1.00
Work Zone On Approach	No			No	No	
Adj Sat Flow, veh/h/ln	1900	1900	1900	1900	1900	1900
Adj Flow Rate, veh/h	157	106	174	1551	586	144
Peak Hour Factor	0.86	0.86	0.86	0.86	0.86	0.86
Percent Heavy Veh, %	0	0	0	0	0	0
Cap, veh/h	195	132	223	2196	1157	284
Arrive On Green	0.19	0.19	0.12	0.61	0.40	0.40
Sat Flow, veh/h	1025	692	1810	3705	2969	704
Grp Volume(v), veh/h	264	0	174	1551	367	363
Grp Sat Flow(s),veh/h/ln	1724	0	1810	1805	1805	1773
Q Serve(g_s), s	8.1	0.0	5.2	16.4	8.5	8.5
Cycle Q Clear(g_c), s	8.1	0.0	5.2	16.4	8.5	8.5
Prop In Lane	0.59	0.40	1.00			0.40
Lane Grp Cap(c), veh/h	329	0	223	2196	727	714
V/C Ratio(X)	0.80	0.00	0.78	0.71	0.51	0.51
Avail Cap(c_a), veh/h	750	0	566	3541	1057	1039
HCM Platoon Ratio	1.00	1.00	1.00	1.00	1.00	1.00
Upstream Filter(I)	1.00	0.00	1.00	1.00	1.00	1.00
Uniform Delay (d), s/veh	21.5	0.0	23.7	7.5	12.5	12.5
Incr Delay (d2), s/veh	4.6	0.0	2.3	0.4	0.5	0.6
Initial Q Delay(d3),s/veh	0.0	0.0	0.0	0.0	0.0	0.0
%ile BackOfQ(50%),veh/ln	3.2	0.0	2.1	3.8	2.8	2.8
Unsig. Movement Delay, s/veh						
LnGrp Delay(d),s/veh	26.1	0.0	25.9	7.9	13.0	13.0
LnGrp LOS	C	A	C	A	B	B
Approach Vol, veh/h	264			1725	730	
Approach Delay, s/veh	26.1			9.7	13.0	
Approach LOS	C			A	B	
Timer - Assigned Phs		2		4	5	6
Phs Duration (G+Y+Rc), s		39.3		16.4	11.4	27.8
Change Period (Y+Rc), s		5.4		5.8	4.6	5.4
Max Green Setting (Gmax), s		54.6		24.2	17.4	32.6
Max Q Clear Time (g_c+11), s		18.4		10.1	7.2	10.5
Green Ext Time (p_c), s		15.4		0.6	0.2	4.3
<b>Intersection Summary</b>						
HCM 6th Ctrl Delay			12.2			
HCM 6th LOS			B			



Intersection						
Int Delay, s/veh	0.1					
Movement	EBL	EBR	NBL	NBT	SBT	SBR
Lane Configurations	↘↗		↘	↑↑	↑↑	
Traffic Vol, veh/h	5	3	4	1473	568	4
Future Vol, veh/h	5	3	4	1473	568	4
Conflicting Peds, #/hr	0	0	0	0	0	0
Sign Control	Stop	Stop	Free	Free	Free	Free
RT Channelized	-	None	-	None	-	None
Storage Length	0	-	100	-	-	-
Veh in Median Storage, #	0	-	-	0	0	-
Grade, %	0	-	-	0	0	-
Peak Hour Factor	92	92	92	92	92	92
Heavy Vehicles, %	0	0	0	0	0	0
Mvmt Flow	5	3	4	1601	617	4

Major/Minor	Minor2	Major1	Major2			
Conflicting Flow All	1428	311	621	0	-	0
Stage 1	619	-	-	-	-	-
Stage 2	809	-	-	-	-	-
Critical Hdwy	6.8	6.9	4.1	-	-	-
Critical Hdwy Stg 1	5.8	-	-	-	-	-
Critical Hdwy Stg 2	5.8	-	-	-	-	-
Follow-up Hdwy	3.5	3.3	2.2	-	-	-
Pot Cap-1 Maneuver	128	691	969	-	-	-
Stage 1	505	-	-	-	-	-
Stage 2	403	-	-	-	-	-
Platoon blocked, %				-	-	-
Mov Cap-1 Maneuver	127	691	969	-	-	-
Mov Cap-2 Maneuver	127	-	-	-	-	-
Stage 1	503	-	-	-	-	-
Stage 2	403	-	-	-	-	-

Approach	EB	NB	SB
HCM Control Delay, s	25.7	0	0
HCM LOS	D		

Minor Lane/Major Mvmt	NBL	NBT	EBLn1	SBT	SBR
Capacity (veh/h)	969	-	183	-	-
HCM Lane V/C Ratio	0.004	-	0.048	-	-
HCM Control Delay (s)	8.7	-	25.7	-	-
HCM Lane LOS	A	-	D	-	-
HCM 95th %tile Q(veh)	0	-	0.1	-	-

Timings  
3: Temescal Canyon Rd & Lawson Rd.



Lane Group	EBL	NBL	NBT	SBT
Lane Configurations				
Traffic Volume (vph)	280	127	639	807
Future Volume (vph)	280	127	639	807
Turn Type	Prot	Prot	NA	NA
Protected Phases	4	5	2	6
Permitted Phases				
Detector Phase	4	5	2	6
Switch Phase				
Minimum Initial (s)	10.0	5.0	10.0	10.0
Minimum Split (s)	28.8	9.6	15.4	33.4
Total Split (s)	32.0	15.0	58.0	43.0
Total Split (%)	35.6%	16.7%	64.4%	47.8%
Yellow Time (s)	4.8	3.6	4.4	4.4
All-Red Time (s)	1.0	1.0	1.0	1.0
Lost Time Adjust (s)	-1.8	-0.6	-1.4	-1.4
Total Lost Time (s)	4.0	4.0	4.0	4.0
Lead/Lag		Lead		Lag
Lead-Lag Optimize?		Yes		Yes
Recall Mode	None	None	Min	Min

Intersection Summary

Cycle Length: 90  
 Actuated Cycle Length: 79.4  
 Natural Cycle: 75  
 Control Type: Actuated-Uncoordinated

Splits and Phases: 3: Temescal Canyon Rd & Lawson Rd.

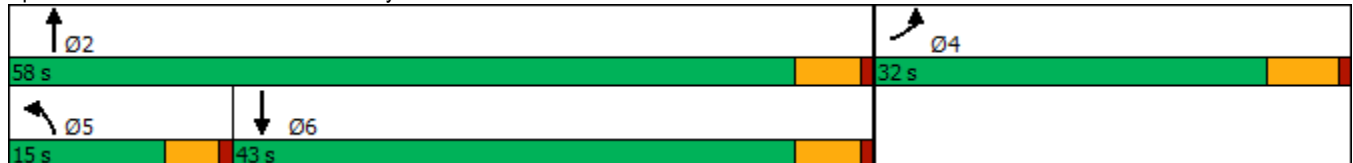

HCM 6th Signalized Intersection Summary  
 3: Temescal Canyon Rd & Lawson Rd.

Glen Ivy Senior Living (JN 13030)  
 09/11/2020



Movement	EBL	EBR	NBL	NBT	SBT	SBR
Lane Configurations						
Traffic Volume (veh/h)	280	106	127	639	807	312
Future Volume (veh/h)	280	106	127	639	807	312
Initial Q (Qb), veh	0	0	0	0	0	0
Ped-Bike Adj(A_pbT)	1.00	1.00	1.00			1.00
Parking Bus, Adj	1.00	1.00	1.00	1.00	1.00	1.00
Work Zone On Approach	No			No	No	
Adj Sat Flow, veh/h/ln	1900	1900	1900	1900	1900	1900
Adj Flow Rate, veh/h	298	113	135	680	859	332
Peak Hour Factor	0.94	0.94	0.94	0.94	0.94	0.94
Percent Heavy Veh, %	0	0	0	0	0	0
Cap, veh/h	364	138	186	2158	1114	429
Arrive On Green	0.29	0.26	0.10	0.60	0.44	0.42
Sat Flow, veh/h	1266	480	1810	3705	2642	981
Grp Volume(v), veh/h	412	0	135	680	608	583
Grp Sat Flow(s),veh/h/ln	1750	0	1810	1805	1805	1723
Q Serve(g_s), s	15.3	0.0	5.0	6.5	19.9	20.2
Cycle Q Clear(g_c), s	15.3	0.0	5.0	6.5	19.9	20.2
Prop In Lane	0.72	0.27	1.00			0.57
Lane Grp Cap(c), veh/h	503	0	186	2158	789	754
V/C Ratio(X)	0.82	0.00	0.73	0.32	0.77	0.77
Avail Cap(c_a), veh/h	704	0	286	2801	1012	966
HCM Platoon Ratio	1.00	1.00	1.00	1.00	1.00	1.00
Upstream Filter(I)	1.00	0.00	1.00	1.00	1.00	1.00
Uniform Delay (d), s/veh	23.4	0.0	30.3	6.9	16.6	17.0
Incr Delay (d2), s/veh	5.3	0.0	2.0	0.1	2.8	3.0
Initial Q Delay(d3),s/veh	0.0	0.0	0.0	0.0	0.0	0.0
%ile BackOfQ(50%),veh/ln	6.3	0.0	2.1	1.9	7.5	7.5
Unsig. Movement Delay, s/veh						
LnGrp Delay(d),s/veh	28.7	0.0	32.3	7.0	19.4	20.0
LnGrp LOS	C	A	C	A	B	C
Approach Vol, veh/h	412			815	1191	
Approach Delay, s/veh	28.7			11.2	19.7	
Approach LOS	C			B	B	
Timer - Assigned Phs		2		4	5	6
Phs Duration (G+Y+Rc), s		45.6		24.0	11.2	34.4
Change Period (Y+Rc), s		5.4		5.8	4.6	5.4
Max Green Setting (Gmax), s		52.6		26.2	10.4	37.6
Max Q Clear Time (g_c+11), s		8.5		17.3	7.0	22.2
Green Ext Time (p_c), s		5.0		0.9	0.0	6.9

Intersection Summary

HCM 6th Ctrl Delay	18.4
HCM 6th LOS	B

Notes

User approved volume balancing among the lanes for turning movement.

Intersection						
Int Delay, s/veh	0.2					
Movement	EBL	EBR	NBL	NBT	SBT	SBR
Lane Configurations						
Traffic Vol, veh/h	8	5	4	638	861	4
Future Vol, veh/h	8	5	4	638	861	4
Conflicting Peds, #/hr	0	0	0	0	0	0
Sign Control	Stop	Stop	Free	Free	Free	Free
RT Channelized	-	None	-	None	-	None
Storage Length	0	-	100	-	-	-
Veh in Median Storage, #	0	-	-	0	0	-
Grade, %	0	-	-	0	0	-
Peak Hour Factor	92	92	92	92	92	92
Heavy Vehicles, %	0	0	0	0	0	0
Mvmt Flow	9	5	4	693	936	4

Major/Minor	Minor2	Major1	Major2			
Conflicting Flow All	1293	470	940	0	-	0
Stage 1	938	-	-	-	-	-
Stage 2	355	-	-	-	-	-
Critical Hdwy	6.8	6.9	4.1	-	-	-
Critical Hdwy Stg 1	5.8	-	-	-	-	-
Critical Hdwy Stg 2	5.8	-	-	-	-	-
Follow-up Hdwy	3.5	3.3	2.2	-	-	-
Pot Cap-1 Maneuver	157	545	737	-	-	-
Stage 1	346	-	-	-	-	-
Stage 2	686	-	-	-	-	-
Platoon blocked, %				-	-	-
Mov Cap-1 Maneuver	156	545	737	-	-	-
Mov Cap-2 Maneuver	156	-	-	-	-	-
Stage 1	344	-	-	-	-	-
Stage 2	686	-	-	-	-	-

Approach	EB	NB	SB
HCM Control Delay, s	22.9	0.1	0
HCM LOS	C		

Minor Lane/Major Mvmt	NBL	NBT	EBLn1	SBT	SBR
Capacity (veh/h)	737	-	215	-	-
HCM Lane V/C Ratio	0.006	-	0.066	-	-
HCM Control Delay (s)	9.9	-	22.9	-	-
HCM Lane LOS	A	-	C	-	-
HCM 95th %tile Q(veh)	0	-	0.2	-	-

**APPENDIX 7.1:**

**HORIZON YEAR (2040) WITHOUT PROJECT CONDITIONS INTERSECTION OPERATIONS  
ANALYSIS WORKSHEETS**



This Page Intentionally Left Blank

Intersection						
Int Delay, s/veh	88.3					
Movement	EBL	EBR	NBL	NBT	SBT	SBR
Lane Configurations	Y		Y	↑	↑	
Traffic Vol, veh/h	155	94	186	1709	613	137
Future Vol, veh/h	155	94	186	1709	613	137
Conflicting Peds, #/hr	0	0	0	0	0	0
Sign Control	Stop	Stop	Free	Free	Free	Free
RT Channelized	-	None	-	None	-	None
Storage Length	0	-	200	-	-	-
Veh in Median Storage, #	2	-	-	0	0	-
Grade, %	0	-	-	0	0	-
Peak Hour Factor	86	86	86	86	86	86
Heavy Vehicles, %	0	0	0	0	0	0
Mvmt Flow	180	109	216	1987	713	159

Major/Minor	Minor2	Major1		Major2	
Conflicting Flow All	3212	793	872	0	0
Stage 1	793	-	-	-	-
Stage 2	2419	-	-	-	-
Critical Hdwy	6.4	6.2	4.1	-	-
Critical Hdwy Stg 1	5.4	-	-	-	-
Critical Hdwy Stg 2	5.4	-	-	-	-
Follow-up Hdwy	3.5	3.3	2.2	-	-
Pot Cap-1 Maneuver	~ 11	392	782	-	-
Stage 1	449	-	-	-	-
Stage 2	~ 71	-	-	-	-
Platoon blocked, %				-	-
Mov Cap-1 Maneuver	~ 8	392	782	-	-
Mov Cap-2 Maneuver	~ 65	-	-	-	-
Stage 1	325	-	-	-	-
Stage 2	~ 71	-	-	-	-

Approach	EB	NB	SB
HCM Control Delay, \$	1017.7	1.1	0
HCM LOS	F		

Minor Lane/Major Mvmt	NBL	NBT	EBLn1	SBT	SBR
Capacity (veh/h)	782	-	95	-	-
HCM Lane V/C Ratio	0.277	-	3.048	-	-
HCM Control Delay (s)	11.4	\$	1017.7	-	-
HCM Lane LOS	B	-	F	-	-
HCM 95th %tile Q(veh)	1.1	-	28.2	-	-

Notes  
 ~: Volume exceeds capacity    \$: Delay exceeds 300s    +: Computation Not Defined    \*: All major volume in platoon

Timings  
4: Temescal Canyon Rd & Trilogy Pkwy



Lane Group	EBL	EBR	NBL	NBT	SBT	SBR
Lane Configurations	↖	↗	↖	↑	↑	↗
Traffic Volume (vph)	90	71	90	1806	611	96
Future Volume (vph)	90	71	90	1806	611	96
Turn Type	Prot	Perm	Prot	NA	NA	Perm
Protected Phases	4		5	2	6	
Permitted Phases		4				6
Detector Phase	4	4	5	2	6	6
Switch Phase						
Minimum Initial (s)	10.0	10.0	5.0	10.0	10.0	10.0
Minimum Split (s)	28.8	28.8	9.6	15.4	33.4	33.4
Total Split (s)	28.8	28.8	10.0	61.2	51.2	51.2
Total Split (%)	32.0%	32.0%	11.1%	68.0%	56.9%	56.9%
Yellow Time (s)	4.8	4.8	3.6	4.4	4.4	4.4
All-Red Time (s)	1.0	1.0	1.0	1.0	1.0	1.0
Lost Time Adjust (s)	-1.8	-1.8	-0.6	-1.4	-1.4	-1.4
Total Lost Time (s)	4.0	4.0	4.0	4.0	4.0	4.0
Lead/Lag			Lead		Lag	Lag
Lead-Lag Optimize?			Yes		Yes	Yes
Recall Mode	None	None	None	None	None	None

Intersection Summary

Cycle Length: 90  
 Actuated Cycle Length: 76.6  
 Natural Cycle: 120  
 Control Type: Actuated-Uncoordinated

Splits and Phases: 4: Temescal Canyon Rd & Trilogy Pkwy

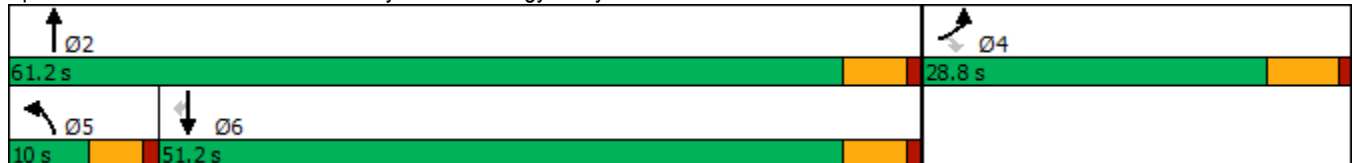

HCM 6th Signalized Intersection Summary  
4: Temescal Canyon Rd & Trilogy Pkwy

Glen Ivy Senior Living (JN 13030)

09/04/2020



Movement	EBL	EBR	NBL	NBT	SBT	SBR
Lane Configurations						
Traffic Volume (veh/h)	90	71	90	1806	611	96
Future Volume (veh/h)	90	71	90	1806	611	96
Initial Q (Qb), veh	0	0	0	0	0	0
Ped-Bike Adj(A_pbT)	1.00	1.00	1.00			1.00
Parking Bus, Adj	1.00	1.00	1.00	1.00	1.00	1.00
Work Zone On Approach	No			No	No	
Adj Sat Flow, veh/h/ln	1900	1900	1900	1900	1900	1900
Adj Flow Rate, veh/h	92	60	92	1843	623	96
Peak Hour Factor	0.98	0.98	0.98	0.98	0.98	0.98
Percent Heavy Veh, %	0	0	0	0	0	0
Cap, veh/h	269	240	132	1419	1181	1001
Arrive On Green	0.15	0.15	0.07	0.75	0.62	0.62
Sat Flow, veh/h	1810	1610	1810	1900	1900	1610
Grp Volume(v), veh/h	92	60	92	1843	623	96
Grp Sat Flow(s),veh/h/ln	1810	1610	1810	1900	1900	1610
Q Serve(g_s), s	3.5	2.5	3.8	57.2	14.1	1.8
Cycle Q Clear(g_c), s	3.5	2.5	3.8	57.2	14.1	1.8
Prop In Lane	1.00	1.00	1.00			1.00
Lane Grp Cap(c), veh/h	269	240	132	1419	1181	1001
V/C Ratio(X)	0.34	0.25	0.70	1.30	0.53	0.10
Avail Cap(c_a), veh/h	586	521	142	1419	1181	1001
HCM Platoon Ratio	1.00	1.00	1.00	1.00	1.00	1.00
Upstream Filter(I)	1.00	1.00	1.00	1.00	1.00	1.00
Uniform Delay (d), s/veh	29.2	28.8	34.7	9.7	8.2	5.8
Incr Delay (d2), s/veh	0.7	0.5	10.4	139.9	0.4	0.0
Initial Q Delay(d3),s/veh	0.0	0.0	0.0	0.0	0.0	0.0
%ile BackOfQ(50%),veh/ln	1.5	0.0	2.0	66.8	4.5	0.5
Unsig. Movement Delay, s/veh						
LnGrp Delay(d),s/veh	30.0	29.4	45.0	149.6	8.6	5.9
LnGrp LOS	C	C	D	F	A	A
Approach Vol, veh/h	152			1935	719	
Approach Delay, s/veh	29.7			144.6	8.2	
Approach LOS	C			F	A	
Timer - Assigned Phs		2		4	5	6
Phs Duration (G+Y+Rc), s		61.2		15.4	9.6	51.6
Change Period (Y+Rc), s		5.4		5.8	4.6	5.4
Max Green Setting (Gmax), s		55.8		23.0	5.4	45.8
Max Q Clear Time (g_c+I1), s		59.2		5.5	5.8	16.1
Green Ext Time (p_c), s		0.0		0.3	0.0	4.6
<b>Intersection Summary</b>						
HCM 6th Ctrl Delay			103.5			
HCM 6th LOS			F			

Intersection						
Int Delay, s/veh	118.4					
Movement	EBL	EBR	NBL	NBT	SBT	SBR
Lane Configurations	↔		↔	↑	↑	
Traffic Vol, veh/h	294	114	137	774	995	340
Future Vol, veh/h	294	114	137	774	995	340
Conflicting Peds, #/hr	0	0	0	0	0	0
Sign Control	Stop	Stop	Free	Free	Free	Free
RT Channelized	-	None	-	None	-	None
Storage Length	0	-	200	-	-	-
Veh in Median Storage, #	2	-	-	0	0	-
Grade, %	0	-	-	0	0	-
Peak Hour Factor	94	94	94	94	94	94
Heavy Vehicles, %	0	0	0	0	0	0
Mvmt Flow	313	121	146	823	1059	362

Major/Minor	Minor2	Major1	Major2			
Conflicting Flow All	2355	1240	1421	0	-	0
Stage 1	1240	-	-	-	-	-
Stage 2	1115	-	-	-	-	-
Critical Hdwy	6.4	6.2	4.1	-	-	-
Critical Hdwy Stg 1	5.4	-	-	-	-	-
Critical Hdwy Stg 2	5.4	-	-	-	-	-
Follow-up Hdwy	3.5	3.3	2.2	-	-	-
Pot Cap-1 Maneuver	~ 40	216	485	-	-	-
Stage 1	~ 276	-	-	-	-	-
Stage 2	316	-	-	-	-	-
Platoon blocked, %				-	-	-
Mov Cap-1 Maneuver	~ 28	216	485	-	-	-
Mov Cap-2 Maneuver	~ 156	-	-	-	-	-
Stage 1	~ 193	-	-	-	-	-
Stage 2	316	-	-	-	-	-

Approach	EB	NB	SB
HCM Control Delay, s	\$ 765.3	2.3	0
HCM LOS	F		

Minor Lane/Major Mvmt	NBL	NBT	EBLn1	SBT	SBR
Capacity (veh/h)	485	-	169	-	-
HCM Lane V/C Ratio	0.301	-	2.568	-	-
HCM Control Delay (s)	15.6	-	\$ 765.3	-	-
HCM Lane LOS	C	-	F	-	-
HCM 95th %tile Q(veh)	1.3	-	37.5	-	-

Notes  
 ~: Volume exceeds capacity    \$: Delay exceeds 300s    +: Computation Not Defined    \*: All major volume in platoon



Timings  
4: Temescal Canyon Rd & Trilogy Pkwy



Lane Group	EBL	EBR	NBL	NBT	SBT	SBR
Lane Configurations	↖	↖	↖	↑	↑	↗
Traffic Volume (vph)	248	103	102	663	952	157
Future Volume (vph)	248	103	102	663	952	157
Turn Type	Prot	Perm	Prot	NA	NA	Perm
Protected Phases	4		5	2	6	
Permitted Phases		4				6
Detector Phase	4	4	5	2	6	6
Switch Phase						
Minimum Initial (s)	10.0	10.0	5.0	10.0	10.0	10.0
Minimum Split (s)	28.8	28.8	9.6	15.4	33.4	33.4
Total Split (s)	31.0	31.0	11.0	59.0	48.0	48.0
Total Split (%)	34.4%	34.4%	12.2%	65.6%	53.3%	53.3%
Yellow Time (s)	4.8	4.8	3.6	4.4	4.4	4.4
All-Red Time (s)	1.0	1.0	1.0	1.0	1.0	1.0
Lost Time Adjust (s)	-1.8	-1.8	-0.6	-1.4	-1.4	-1.4
Total Lost Time (s)	4.0	4.0	4.0	4.0	4.0	4.0
Lead/Lag			Lead		Lag	Lag
Lead-Lag Optimize?			Yes		Yes	Yes
Recall Mode	None	None	None	None	None	None

Intersection Summary

Cycle Length: 90  
 Actuated Cycle Length: 81.7  
 Natural Cycle: 90  
 Control Type: Actuated-Uncoordinated

Splits and Phases: 4: Temescal Canyon Rd & Trilogy Pkwy

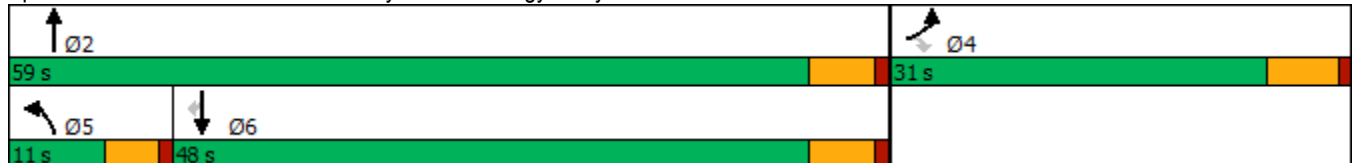

HCM 6th Signalized Intersection Summary  
4: Temescal Canyon Rd & Trilogy Pkwy

Glen Ivy Senior Living (JN 13030)  
09/04/2020



Movement	EBL	EBR	NBL	NBT	SBT	SBR
Lane Configurations						
Traffic Volume (veh/h)	248	103	102	663	952	157
Future Volume (veh/h)	248	103	102	663	952	157
Initial Q (Qb), veh	0	0	0	0	0	0
Ped-Bike Adj(A_pbT)	1.00	1.00	1.00			0.98
Parking Bus, Adj	1.00	1.00	1.00	1.00	1.00	1.00
Work Zone On Approach	No			No	No	
Adj Sat Flow, veh/h/ln	1900	1900	1900	1900	1900	1900
Adj Flow Rate, veh/h	258	91	106	691	992	152
Peak Hour Factor	0.96	0.96	0.96	0.96	0.96	0.96
Percent Heavy Veh, %	0	0	0	0	0	0
Cap, veh/h	354	315	149	1327	1069	887
Arrive On Green	0.20	0.20	0.08	0.70	0.56	0.56
Sat Flow, veh/h	1810	1610	1810	1900	1900	1577
Grp Volume(v), veh/h	258	91	106	691	992	152
Grp Sat Flow(s),veh/h/ln	1810	1610	1810	1900	1900	1577
Q Serve(g_s), s	10.1	3.6	4.3	13.0	35.9	3.5
Cycle Q Clear(g_c), s	10.1	3.6	4.3	13.0	35.9	3.5
Prop In Lane	1.00	1.00	1.00			1.00
Lane Grp Cap(c), veh/h	354	315	149	1327	1069	887
V/C Ratio(X)	0.73	0.29	0.71	0.52	0.93	0.17
Avail Cap(c_a), veh/h	650	578	169	1390	1112	923
HCM Platoon Ratio	1.00	1.00	1.00	1.00	1.00	1.00
Upstream Filter(I)	1.00	1.00	1.00	1.00	1.00	1.00
Uniform Delay (d), s/veh	28.4	25.8	33.6	5.4	15.1	8.0
Incr Delay (d2), s/veh	2.9	0.5	8.8	0.3	12.9	0.1
Initial Q Delay(d3),s/veh	0.0	0.0	0.0	0.0	0.0	0.0
%ile BackOfQ(50%),veh/ln	4.3	3.5	2.1	3.3	15.9	1.0
Unsig. Movement Delay, s/veh						
LnGrp Delay(d),s/veh	31.3	26.3	42.4	5.7	28.0	8.1
LnGrp LOS	C	C	D	A	C	A
Approach Vol, veh/h	349			797	1144	
Approach Delay, s/veh	30.0			10.6	25.3	
Approach LOS	C			B	C	
Timer - Assigned Phs		2		4	5	6
Phs Duration (G+Y+Rc), s		56.5		18.7	10.2	46.3
Change Period (Y+Rc), s		5.4		5.8	4.6	5.4
Max Green Setting (Gmax), s		53.6		25.2	6.4	42.6
Max Q Clear Time (g_c+1), s		15.0		12.1	6.3	37.9
Green Ext Time (p_c), s		5.1		0.8	0.0	2.9
<b>Intersection Summary</b>						
HCM 6th Ctrl Delay			20.9			
HCM 6th LOS			C			

**APPENDIX 7.2:**

**HORIZON YEAR (2040) WITH PROJECT (RIRO AT DRIVEWAY 4) CONDITIONS  
INTERSECTION OPERATIONS ANALYSIS WORKSHEETS**

This Page Intentionally Left Blank

Intersection						
Int Delay, s/veh	0.3					
Movement	EBT	EBR	WBL	WBT	NBL	NBR
Lane Configurations	↑↑		↖	↑↑	↘	
Traffic Vol, veh/h	163	1	9	187	2	5
Future Vol, veh/h	163	1	9	187	2	5
Conflicting Peds, #/hr	0	0	0	0	0	0
Sign Control	Free	Free	Free	Free	Stop	Stop
RT Channelized	-	None	-	None	-	None
Storage Length	-	-	100	-	0	-
Veh in Median Storage, #	0	-	-	0	0	-
Grade, %	0	-	-	0	0	-
Peak Hour Factor	92	92	92	92	92	92
Heavy Vehicles, %	0	0	0	0	0	0
Mvmt Flow	177	1	10	203	2	5

Major/Minor	Major1	Major2	Minor1		
Conflicting Flow All	0	0	178	0	300
Stage 1	-	-	-	-	178
Stage 2	-	-	-	-	122
Critical Hdwy	-	-	4.1	-	6.8
Critical Hdwy Stg 1	-	-	-	-	5.8
Critical Hdwy Stg 2	-	-	-	-	5.8
Follow-up Hdwy	-	-	2.2	-	3.5
Pot Cap-1 Maneuver	-	-	1410	-	673
Stage 1	-	-	-	-	841
Stage 2	-	-	-	-	896
Platoon blocked, %	-	-	-	-	-
Mov Cap-1 Maneuver	-	-	1410	-	668
Mov Cap-2 Maneuver	-	-	-	-	668
Stage 1	-	-	-	-	841
Stage 2	-	-	-	-	890

Approach	EB	WB	NB
HCM Control Delay, s	0	0.3	9.3
HCM LOS			A

Minor Lane/Major Mvmt	NBLn1	EBT	EBR	WBL	WBT
Capacity (veh/h)	852	-	-	1410	-
HCM Lane V/C Ratio	0.009	-	-	0.007	-
HCM Control Delay (s)	9.3	-	-	7.6	-
HCM Lane LOS	A	-	-	A	-
HCM 95th %tile Q(veh)	0	-	-	0	-



Intersection						
Int Delay, s/veh	0.2					
Movement	EBT	EBR	WBL	WBT	NBL	NBR
Lane Configurations	↑↑			↑↑		↑
Traffic Vol, veh/h	167	1	0	196	0	9
Future Vol, veh/h	167	1	0	196	0	9
Conflicting Peds, #/hr	0	0	0	0	0	0
Sign Control	Free	Free	Free	Free	Stop	Stop
RT Channelized	-	None	-	None	-	None
Storage Length	-	-	-	-	-	0
Veh in Median Storage, #	0	-	-	0	0	-
Grade, %	0	-	-	0	0	-
Peak Hour Factor	92	92	92	92	92	92
Heavy Vehicles, %	0	0	0	0	0	0
Mvmt Flow	182	1	0	213	0	10

Major/Minor	Major1	Major2	Minor1	Minor2	Minor3
Conflicting Flow All	0	0	-	-	92
Stage 1	-	-	-	-	-
Stage 2	-	-	-	-	-
Critical Hdwy	-	-	-	-	6.9
Critical Hdwy Stg 1	-	-	-	-	-
Critical Hdwy Stg 2	-	-	-	-	-
Follow-up Hdwy	-	-	-	-	3.3
Pot Cap-1 Maneuver	-	-	0	-	954
Stage 1	-	-	0	-	-
Stage 2	-	-	0	-	-
Platoon blocked, %	-	-	-	-	-
Mov Cap-1 Maneuver	-	-	-	-	954
Mov Cap-2 Maneuver	-	-	-	-	-
Stage 1	-	-	-	-	-
Stage 2	-	-	-	-	-

Approach	EB	WB	NB
HCM Control Delay, s	0	0	8.8
HCM LOS			A

Minor Lane/Major Mvmt	NBLn1	EBT	EBR	WBT
Capacity (veh/h)	954	-	-	-
HCM Lane V/C Ratio	0.01	-	-	-
HCM Control Delay (s)	8.8	-	-	-
HCM Lane LOS	A	-	-	-
HCM 95th %tile Q(veh)	0	-	-	-

Intersection						
Int Delay, s/veh	87.4					
Movement	EBL	EBR	NBL	NBT	SBT	SBR
Lane Configurations	Y		Y	↑	↑	
Traffic Vol, veh/h	155	94	186	1723	629	137
Future Vol, veh/h	155	94	186	1723	629	137
Conflicting Peds, #/hr	0	0	0	0	0	0
Sign Control	Stop	Stop	Free	Free	Free	Free
RT Channelized	-	None	-	None	-	None
Storage Length	0	-	200	-	-	-
Veh in Median Storage, #	2	-	-	0	0	-
Grade, %	0	-	-	0	0	-
Peak Hour Factor	86	86	86	86	86	86
Heavy Vehicles, %	0	0	0	0	0	0
Mvmt Flow	180	109	216	2003	731	159

Major/Minor	Minor2	Major1		Major2	
Conflicting Flow All	3246	811	890	0	0
Stage 1	811	-	-	-	-
Stage 2	2435	-	-	-	-
Critical Hdwy	6.4	6.2	4.1	-	-
Critical Hdwy Stg 1	5.4	-	-	-	-
Critical Hdwy Stg 2	5.4	-	-	-	-
Follow-up Hdwy	3.5	3.3	2.2	-	-
Pot Cap-1 Maneuver	~ 11	383	770	-	-
Stage 1	440	-	-	-	-
Stage 2	~ 70	-	-	-	-
Platoon blocked, %				-	-
Mov Cap-1 Maneuver	~ 8	383	770	-	-
Mov Cap-2 Maneuver	~ 65	-	-	-	-
Stage 1	316	-	-	-	-
Stage 2	~ 70	-	-	-	-

Approach	EB	NB	SB
HCM Control Delay, \$	1017.7	1.1	0
HCM LOS	F		

Minor Lane/Major Mvmt	NBL	NBT	EBLn1	SBT	SBR
Capacity (veh/h)	770	-	95	-	-
HCM Lane V/C Ratio	0.281	-	3.048	-	-
HCM Control Delay (s)	11.5	\$	1017.7	-	-
HCM Lane LOS	B	-	F	-	-
HCM 95th %tile Q(veh)	1.2	-	28.2	-	-

Notes  
 ~: Volume exceeds capacity    \$: Delay exceeds 300s    +: Computation Not Defined    \*: All major volume in platoon

Timings  
4: Temescal Canyon Rd & Trilogy Pkwy



Lane Group	EBL	EBR	NBL	NBT	SBT	SBR
Lane Configurations	↖	↗	↖	↑	↑	↗
Traffic Volume (vph)	104	72	96	1806	625	98
Future Volume (vph)	104	72	96	1806	625	98
Turn Type	Prot	Perm	Prot	NA	NA	Perm
Protected Phases	4		5	2	6	
Permitted Phases		4				6
Detector Phase	4	4	5	2	6	6
Switch Phase						
Minimum Initial (s)	10.0	10.0	5.0	10.0	10.0	10.0
Minimum Split (s)	28.8	28.8	9.6	15.4	33.4	33.4
Total Split (s)	28.8	28.8	10.0	61.2	51.2	51.2
Total Split (%)	32.0%	32.0%	11.1%	68.0%	56.9%	56.9%
Yellow Time (s)	4.8	4.8	3.6	4.4	4.4	4.4
All-Red Time (s)	1.0	1.0	1.0	1.0	1.0	1.0
Lost Time Adjust (s)	-1.8	-1.8	-0.6	-1.4	-1.4	-1.4
Total Lost Time (s)	4.0	4.0	4.0	4.0	4.0	4.0
Lead/Lag			Lead		Lag	Lag
Lead-Lag Optimize?			Yes		Yes	Yes
Recall Mode	None	None	None	None	None	None

Intersection Summary

Cycle Length: 90  
 Actuated Cycle Length: 76.7  
 Natural Cycle: 120  
 Control Type: Actuated-Uncoordinated

Splits and Phases: 4: Temescal Canyon Rd & Trilogy Pkwy

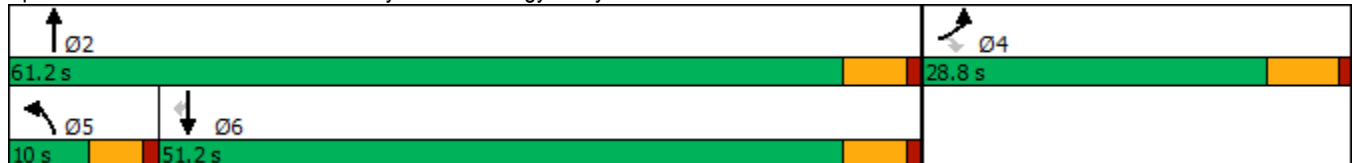

HCM 6th Signalized Intersection Summary  
4: Temescal Canyon Rd & Trilogy Pkwy

Glen Ivy Senior Living (JN 13030)  
09/11/2020



Movement	EBL	EBR	NBL	NBT	SBT	SBR
Lane Configurations						
Traffic Volume (veh/h)	104	72	96	1806	625	98
Future Volume (veh/h)	104	72	96	1806	625	98
Initial Q (Qb), veh	0	0	0	0	0	0
Ped-Bike Adj(A_pbT)	1.00	1.00	1.00			1.00
Parking Bus, Adj	1.00	1.00	1.00	1.00	1.00	1.00
Work Zone On Approach	No			No	No	
Adj Sat Flow, veh/h/ln	1900	1900	1900	1900	1900	1900
Adj Flow Rate, veh/h	106	61	98	1843	638	98
Peak Hour Factor	0.98	0.98	0.98	0.98	0.98	0.98
Percent Heavy Veh, %	0	0	0	0	0	0
Cap, veh/h	272	242	139	1417	1171	993
Arrive On Green	0.15	0.15	0.08	0.75	0.62	0.62
Sat Flow, veh/h	1810	1610	1810	1900	1900	1610
Grp Volume(v), veh/h	106	61	98	1843	638	98
Grp Sat Flow(s),veh/h/ln	1810	1610	1810	1900	1900	1610
Q Serve(g_s), s	4.1	2.6	4.1	57.2	14.9	1.9
Cycle Q Clear(g_c), s	4.1	2.6	4.1	57.2	14.9	1.9
Prop In Lane	1.00	1.00	1.00			1.00
Lane Grp Cap(c), veh/h	272	242	139	1417	1171	993
V/C Ratio(X)	0.39	0.25	0.70	1.30	0.54	0.10
Avail Cap(c_a), veh/h	585	521	142	1417	1171	993
HCM Platoon Ratio	1.00	1.00	1.00	1.00	1.00	1.00
Upstream Filter(I)	1.00	1.00	1.00	1.00	1.00	1.00
Uniform Delay (d), s/veh	29.4	28.8	34.6	9.8	8.5	6.0
Incr Delay (d2), s/veh	0.9	0.5	12.2	140.7	0.5	0.0
Initial Q Delay(d3),s/veh	0.0	0.0	0.0	0.0	0.0	0.0
%ile BackOfQ(50%),veh/ln	1.7	0.0	2.2	67.1	4.8	0.5
Unsig. Movement Delay, s/veh						
LnGrp Delay(d),s/veh	30.3	29.3	46.8	150.5	9.0	6.0
LnGrp LOS	C	C	D	F	A	A
Approach Vol, veh/h	167			1941	736	
Approach Delay, s/veh	30.0			145.2	8.6	
Approach LOS	C			F	A	
Timer - Assigned Phs		2		4	5	6
Phs Duration (G+Y+Rc), s		61.2		15.5	9.9	51.3
Change Period (Y+Rc), s		5.4		5.8	4.6	5.4
Max Green Setting (Gmax), s		55.8		23.0	5.4	45.8
Max Q Clear Time (g_c+1), s		59.2		6.1	6.1	16.9
Green Ext Time (p_c), s		0.0		0.4	0.0	4.7
<b>Intersection Summary</b>						
HCM 6th Ctrl Delay			103.1			
HCM 6th LOS			F			

Intersection						
Int Delay, s/veh	0					
Movement	EBL	EBR	NBL	NBT	SBT	SBR
Lane Configurations		↗		↑	↘	
Traffic Vol, veh/h	0	1	0	1902	703	10
Future Vol, veh/h	0	1	0	1902	703	10
Conflicting Peds, #/hr	0	0	0	0	0	0
Sign Control	Stop	Stop	Free	Free	Free	Free
RT Channelized	-	None	-	None	-	None
Storage Length	-	0	-	-	-	-
Veh in Median Storage, #	0	-	-	0	0	-
Grade, %	0	-	-	0	0	-
Peak Hour Factor	92	92	92	92	92	92
Heavy Vehicles, %	0	0	0	0	0	0
Mvmt Flow	0	1	0	2067	764	11

Major/Minor	Minor2	Major1	Major2		
Conflicting Flow All	-	770	-	0	-
Stage 1	-	-	-	-	-
Stage 2	-	-	-	-	-
Critical Hdwy	-	6.2	-	-	-
Critical Hdwy Stg 1	-	-	-	-	-
Critical Hdwy Stg 2	-	-	-	-	-
Follow-up Hdwy	-	3.3	-	-	-
Pot Cap-1 Maneuver	0	404	0	-	-
Stage 1	0	-	0	-	-
Stage 2	0	-	0	-	-
Platoon blocked, %				-	-
Mov Cap-1 Maneuver	-	404	-	-	-
Mov Cap-2 Maneuver	-	-	-	-	-
Stage 1	-	-	-	-	-
Stage 2	-	-	-	-	-

Approach	EB	NB	SB
HCM Control Delay, s	13.9	0	0
HCM LOS	B		

Minor Lane/Major Mvmt	NBT EBLn1	SBT	SBR
Capacity (veh/h)	- 404	-	-
HCM Lane V/C Ratio	- 0.003	-	-
HCM Control Delay (s)	- 13.9	-	-
HCM Lane LOS	- B	-	-
HCM 95th %tile Q(veh)	- 0	-	-



Intersection						
Int Delay, s/veh	0					
Movement	EBL	EBR	NBL	NBT	SBT	SBR
Lane Configurations		↗		↑	↘	
Traffic Vol, veh/h	0	3	0	1902	701	4
Future Vol, veh/h	0	3	0	1902	701	4
Conflicting Peds, #/hr	0	0	0	0	0	0
Sign Control	Stop	Stop	Free	Free	Free	Free
RT Channelized	-	None	-	None	-	None
Storage Length	-	0	-	-	-	-
Veh in Median Storage, #	0	-	-	0	0	-
Grade, %	0	-	-	0	0	-
Peak Hour Factor	92	92	92	92	92	92
Heavy Vehicles, %	0	0	0	0	0	0
Mvmt Flow	0	3	0	2067	762	4

Major/Minor	Minor2	Major1	Major2		
Conflicting Flow All	-	764	-	0	-
Stage 1	-	-	-	-	-
Stage 2	-	-	-	-	-
Critical Hdwy	-	6.2	-	-	-
Critical Hdwy Stg 1	-	-	-	-	-
Critical Hdwy Stg 2	-	-	-	-	-
Follow-up Hdwy	-	3.3	-	-	-
Pot Cap-1 Maneuver	0	407	0	-	-
Stage 1	0	-	0	-	-
Stage 2	0	-	0	-	-
Platoon blocked, %				-	-
Mov Cap-1 Maneuver	-	407	-	-	-
Mov Cap-2 Maneuver	-	-	-	-	-
Stage 1	-	-	-	-	-
Stage 2	-	-	-	-	-

Approach	EB	NB	SB
HCM Control Delay, s	13.9	0	0
HCM LOS	B		

Minor Lane/Major Mvmt	NBT EBLn1	SBT	SBR
Capacity (veh/h)	- 407	-	-
HCM Lane V/C Ratio	- 0.008	-	-
HCM Control Delay (s)	- 13.9	-	-
HCM Lane LOS	- B	-	-
HCM 95th %tile Q(veh)	- 0	-	-

Intersection						
Int Delay, s/veh	0.3					
Movement	EBT	EBR	WBL	WBT	NBL	NBR
Lane Configurations	↑↑		↖	↑↑	↘	
Traffic Vol, veh/h	353	1	9	259	4	9
Future Vol, veh/h	353	1	9	259	4	9
Conflicting Peds, #/hr	0	0	0	0	0	0
Sign Control	Free	Free	Free	Free	Stop	Stop
RT Channelized	-	None	-	None	-	None
Storage Length	-	-	100	-	0	-
Veh in Median Storage, #	0	-	-	0	0	-
Grade, %	0	-	-	0	0	-
Peak Hour Factor	92	92	92	92	92	92
Heavy Vehicles, %	0	0	0	0	0	0
Mvmt Flow	384	1	10	282	4	10

Major/Minor	Major1	Major2	Minor1	Minor2	Minor3
Conflicting Flow All	0	0	385	0	546
Stage 1	-	-	-	-	385
Stage 2	-	-	-	-	161
Critical Hdwy	-	-	4.1	-	6.8
Critical Hdwy Stg 1	-	-	-	-	5.8
Critical Hdwy Stg 2	-	-	-	-	5.8
Follow-up Hdwy	-	-	2.2	-	3.5
Pot Cap-1 Maneuver	-	-	1185	-	473
Stage 1	-	-	-	-	663
Stage 2	-	-	-	-	857
Platoon blocked, %	-	-	-	-	-
Mov Cap-1 Maneuver	-	-	1185	-	469
Mov Cap-2 Maneuver	-	-	-	-	469
Stage 1	-	-	-	-	663
Stage 2	-	-	-	-	850

Approach	EB	WB	NB
HCM Control Delay, s	0	0.3	10.5
HCM LOS			B

Minor Lane/Major Mvmt	NBLn1	EBT	EBR	WBL	WBT
Capacity (veh/h)	667	-	-	1185	-
HCM Lane V/C Ratio	0.021	-	-	0.008	-
HCM Control Delay (s)	10.5	-	-	8.1	-
HCM Lane LOS	B	-	-	A	-
HCM 95th %tile Q(veh)	0.1	-	-	0	-

Intersection						
Int Delay, s/veh	0.2					
Movement	EBT	EBR	WBL	WBT	NBL	NBR
Lane Configurations	↑↑			↑↑		↑
Traffic Vol, veh/h	361	1	0	268	0	16
Future Vol, veh/h	361	1	0	268	0	16
Conflicting Peds, #/hr	0	0	0	0	0	0
Sign Control	Free	Free	Free	Free	Stop	Stop
RT Channelized	-	None	-	None	-	None
Storage Length	-	-	-	-	-	0
Veh in Median Storage, #	0	-	-	0	0	-
Grade, %	0	-	-	0	0	-
Peak Hour Factor	92	92	92	92	92	92
Heavy Vehicles, %	0	0	0	0	0	0
Mvmt Flow	392	1	0	291	0	17

Major/Minor	Major1	Major2	Minor1		
Conflicting Flow All	0	0	-	-	197
Stage 1	-	-	-	-	-
Stage 2	-	-	-	-	-
Critical Hdwy	-	-	-	-	6.9
Critical Hdwy Stg 1	-	-	-	-	-
Critical Hdwy Stg 2	-	-	-	-	-
Follow-up Hdwy	-	-	-	-	3.3
Pot Cap-1 Maneuver	-	0	-	0	817
Stage 1	-	0	-	0	-
Stage 2	-	0	-	0	-
Platoon blocked, %	-	-	-	-	-
Mov Cap-1 Maneuver	-	-	-	-	817
Mov Cap-2 Maneuver	-	-	-	-	-
Stage 1	-	-	-	-	-
Stage 2	-	-	-	-	-

Approach	EB	WB	NB
HCM Control Delay, s	0	0	9.5
HCM LOS			A

Minor Lane/Major Mvmt	NBLn1	EBT	EBR	WBT
Capacity (veh/h)	817	-	-	-
HCM Lane V/C Ratio	0.021	-	-	-
HCM Control Delay (s)	9.5	-	-	-
HCM Lane LOS	A	-	-	-
HCM 95th %tile Q(veh)	0.1	-	-	-

Intersection						
Int Delay, s/veh	122.2					
Movement	EBL	EBR	NBL	NBT	SBT	SBR
Lane Configurations	Y		Y	↑	↑	
Traffic Vol, veh/h	294	114	137	797	1013	340
Future Vol, veh/h	294	114	137	797	1013	340
Conflicting Peds, #/hr	0	0	0	0	0	0
Sign Control	Stop	Stop	Free	Free	Free	Free
RT Channelized	-	None	-	None	-	None
Storage Length	0	-	200	-	-	-
Veh in Median Storage, #	2	-	-	0	0	-
Grade, %	0	-	-	0	0	-
Peak Hour Factor	94	94	94	94	94	94
Heavy Vehicles, %	0	0	0	0	0	0
Mvmt Flow	313	121	146	848	1078	362

Major/Minor	Minor2	Major1	Major2			
Conflicting Flow All	2399	1259	1440	0	-	0
Stage 1	1259	-	-	-	-	-
Stage 2	1140	-	-	-	-	-
Critical Hdwy	6.4	6.2	4.1	-	-	-
Critical Hdwy Stg 1	5.4	-	-	-	-	-
Critical Hdwy Stg 2	5.4	-	-	-	-	-
Follow-up Hdwy	3.5	3.3	2.2	-	-	-
Pot Cap-1 Maneuver	~ 37	210	477	-	-	-
Stage 1	~ 270	-	-	-	-	-
Stage 2	~ 308	-	-	-	-	-
Platoon blocked, %				-	-	-
Mov Cap-1 Maneuver	~ 26	210	477	-	-	-
Mov Cap-2 Maneuver	~ 151	-	-	-	-	-
Stage 1	~ 187	-	-	-	-	-
Stage 2	~ 308	-	-	-	-	-

Approach	EB	NB	SB
HCM Control Delay, s	\$ 801.7	2.3	0
HCM LOS	F		

Minor Lane/Major Mvmt	NBL	NBT	EBLn1	SBT	SBR
Capacity (veh/h)	477	-	164	-	-
HCM Lane V/C Ratio	0.306	-	2.647	-	-
HCM Control Delay (s)	15.8	-	\$ 801.7	-	-
HCM Lane LOS	C	-	F	-	-
HCM 95th %tile Q(veh)	1.3	-	38	-	-

Notes  
 ~: Volume exceeds capacity    \$: Delay exceeds 300s    +: Computation Not Defined    \*: All major volume in platoon

Timings  
4: Temescal Canyon Rd & Trilogy Pkwy



Lane Group	EBL	EBR	NBL	NBT	SBT	SBR
Lane Configurations	↖	↗	↖	↑	↑	↗
Traffic Volume (vph)	271	105	109	663	967	160
Future Volume (vph)	271	105	109	663	967	160
Turn Type	Prot	Perm	Prot	NA	NA	Perm
Protected Phases	4		5	2	6	
Permitted Phases		4				6
Detector Phase	4	4	5	2	6	6
Switch Phase						
Minimum Initial (s)	10.0	10.0	5.0	10.0	10.0	10.0
Minimum Split (s)	28.8	28.8	9.6	15.4	33.4	33.4
Total Split (s)	31.0	31.0	11.0	59.0	48.0	48.0
Total Split (%)	34.4%	34.4%	12.2%	65.6%	53.3%	53.3%
Yellow Time (s)	4.8	4.8	3.6	4.4	4.4	4.4
All-Red Time (s)	1.0	1.0	1.0	1.0	1.0	1.0
Lost Time Adjust (s)	-1.8	-1.8	-0.6	-1.4	-1.4	-1.4
Total Lost Time (s)	4.0	4.0	4.0	4.0	4.0	4.0
Lead/Lag			Lead		Lag	Lag
Lead-Lag Optimize?			Yes		Yes	Yes
Recall Mode	None	None	None	None	None	None

Intersection Summary

Cycle Length: 90  
 Actuated Cycle Length: 82.9  
 Natural Cycle: 90  
 Control Type: Actuated-Uncoordinated

Splits and Phases: 4: Temescal Canyon Rd & Trilogy Pkwy

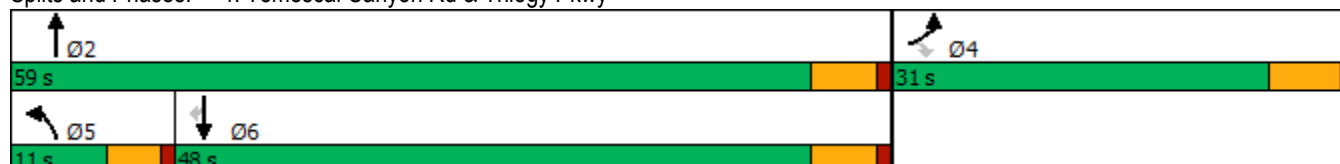



HCM 6th Signalized Intersection Summary  
4: Temescal Canyon Rd & Trilogy Pkwy

Glen Ivy Senior Living (JN 13030)  
09/11/2020



Movement	EBL	EBR	NBL	NBT	SBT	SBR
Lane Configurations						
Traffic Volume (veh/h)	271	105	109	663	967	160
Future Volume (veh/h)	271	105	109	663	967	160
Initial Q (Qb), veh	0	0	0	0	0	0
Ped-Bike Adj(A_pbT)	1.00	1.00	1.00			0.98
Parking Bus, Adj	1.00	1.00	1.00	1.00	1.00	1.00
Work Zone On Approach	No			No	No	
Adj Sat Flow, veh/h/ln	1900	1900	1900	1900	1900	1900
Adj Flow Rate, veh/h	282	93	114	691	1007	155
Peak Hour Factor	0.96	0.96	0.96	0.96	0.96	0.96
Percent Heavy Veh, %	0	0	0	0	0	0
Cap, veh/h	372	331	158	1316	1054	875
Arrive On Green	0.21	0.21	0.09	0.69	0.55	0.55
Sat Flow, veh/h	1810	1610	1810	1900	1900	1577
Grp Volume(v), veh/h	282	93	114	691	1007	155
Grp Sat Flow(s),veh/h/ln	1810	1610	1810	1900	1900	1577
Q Serve(g_s), s	11.6	3.8	4.8	13.8	39.6	3.8
Cycle Q Clear(g_c), s	11.6	3.8	4.8	13.8	39.6	3.8
Prop In Lane	1.00	1.00	1.00			1.00
Lane Grp Cap(c), veh/h	372	331	158	1316	1054	875
V/C Ratio(X)	0.76	0.28	0.72	0.53	0.96	0.18
Avail Cap(c_a), veh/h	620	552	161	1326	1061	880
HCM Platoon Ratio	1.00	1.00	1.00	1.00	1.00	1.00
Upstream Filter(I)	1.00	1.00	1.00	1.00	1.00	1.00
Uniform Delay (d), s/veh	29.4	26.4	35.0	5.8	16.6	8.7
Incr Delay (d2), s/veh	3.2	0.5	12.5	0.4	17.8	0.1
Initial Q Delay(d3),s/veh	0.0	0.0	0.0	0.0	0.0	0.0
%ile BackOfQ(50%),veh/ln	4.9	0.0	2.6	3.8	19.0	1.1
Unsig. Movement Delay, s/veh						
LnGrp Delay(d),s/veh	32.6	26.8	47.6	6.2	34.5	8.8
LnGrp LOS	C	C	D	A	C	A
Approach Vol, veh/h	375			805	1162	
Approach Delay, s/veh	31.2			12.1	31.0	
Approach LOS	C			B	C	
Timer - Assigned Phs		2		4	5	6
Phs Duration (G+Y+Rc), s		58.6		20.2	10.9	47.7
Change Period (Y+Rc), s		5.4		5.8	4.6	5.4
Max Green Setting (Gmax), s		53.6		25.2	6.4	42.6
Max Q Clear Time (g_c+11), s		15.8		13.6	6.8	41.6
Green Ext Time (p_c), s		5.1		0.9	0.0	0.7
<b>Intersection Summary</b>						
HCM 6th Ctrl Delay			24.5			
HCM 6th LOS			C			

Intersection						
Int Delay, s/veh	0					
Movement	EBL	EBR	NBL	NBT	SBT	SBR
Lane Configurations		↗		↑	↘	
Traffic Vol, veh/h	0	3	0	772	1078	11
Future Vol, veh/h	0	3	0	772	1078	11
Conflicting Peds, #/hr	0	0	0	0	0	0
Sign Control	Stop	Stop	Free	Free	Free	Free
RT Channelized	-	None	-	None	-	None
Storage Length	-	0	-	-	-	-
Veh in Median Storage, #	0	-	-	0	0	-
Grade, %	0	-	-	0	0	-
Peak Hour Factor	92	92	92	92	92	92
Heavy Vehicles, %	0	0	0	0	0	0
Mvmt Flow	0	3	0	839	1172	12

Major/Minor	Minor2	Major1	Major2		
Conflicting Flow All	-	1178	-	0	-
Stage 1	-	-	-	-	-
Stage 2	-	-	-	-	-
Critical Hdwy	-	6.2	-	-	-
Critical Hdwy Stg 1	-	-	-	-	-
Critical Hdwy Stg 2	-	-	-	-	-
Follow-up Hdwy	-	3.3	-	-	-
Pot Cap-1 Maneuver	0	235	0	-	-
Stage 1	0	-	0	-	-
Stage 2	0	-	0	-	-
Platoon blocked, %				-	-
Mov Cap-1 Maneuver	-	235	-	-	-
Mov Cap-2 Maneuver	-	-	-	-	-
Stage 1	-	-	-	-	-
Stage 2	-	-	-	-	-

Approach	EB	NB	SB
HCM Control Delay, s	20.5	0	0
HCM LOS	C		

Minor Lane/Major Mvmt	NBT	EBLn1	SBT	SBR
Capacity (veh/h)	-	235	-	-
HCM Lane V/C Ratio	-	0.014	-	-
HCM Control Delay (s)	-	20.5	-	-
HCM Lane LOS	-	C	-	-
HCM 95th %tile Q(veh)	-	0	-	-

Intersection						
Int Delay, s/veh	0.1					
Movement	EBL	EBR	NBL	NBT	SBT	SBR
Lane Configurations		↗		↑	↘	
Traffic Vol, veh/h	0	5	0	772	1076	4
Future Vol, veh/h	0	5	0	772	1076	4
Conflicting Peds, #/hr	0	0	0	0	0	0
Sign Control	Stop	Stop	Free	Free	Free	Free
RT Channelized	-	None	-	None	-	None
Storage Length	-	0	-	-	-	-
Veh in Median Storage, #	0	-	-	0	0	-
Grade, %	0	-	-	0	0	-
Peak Hour Factor	92	92	92	92	92	92
Heavy Vehicles, %	0	0	0	0	0	0
Mvmt Flow	0	5	0	839	1170	4

Major/Minor	Minor2	Major1	Major2		
Conflicting Flow All	-	1172	-	0	-
Stage 1	-	-	-	-	-
Stage 2	-	-	-	-	-
Critical Hdwy	-	6.2	-	-	-
Critical Hdwy Stg 1	-	-	-	-	-
Critical Hdwy Stg 2	-	-	-	-	-
Follow-up Hdwy	-	3.3	-	-	-
Pot Cap-1 Maneuver	0	236	0	-	-
Stage 1	0	-	0	-	-
Stage 2	0	-	0	-	-
Platoon blocked, %				-	-
Mov Cap-1 Maneuver	-	236	-	-	-
Mov Cap-2 Maneuver	-	-	-	-	-
Stage 1	-	-	-	-	-
Stage 2	-	-	-	-	-

Approach	EB	NB	SB
HCM Control Delay, s	20.6	0	0
HCM LOS	C		

Minor Lane/Major Mvmt	NBT EBLn1	SBT	SBR
Capacity (veh/h)	- 236	-	-
HCM Lane V/C Ratio	- 0.023	-	-
HCM Control Delay (s)	- 20.6	-	-
HCM Lane LOS	- C	-	-
HCM 95th %tile Q(veh)	- 0.1	-	-

**APPENDIX 7.3:**

**HORIZON YEAR (2040) WITH PROJECT (FULL ACCESS AT DRIVEWAY 4) CONDITIONS  
INTERSECTION OPERATIONS ANALYSIS WORKSHEETS**

This Page Intentionally Left Blank



Intersection						
Int Delay, s/veh	0.2					
Movement	EBT	EBR	WBL	WBT	NBL	NBR
Lane Configurations	↑↑		↖	↑↑	↘	
Traffic Vol, veh/h	163	1	5	187	2	3
Future Vol, veh/h	163	1	5	187	2	3
Conflicting Peds, #/hr	0	0	0	0	0	0
Sign Control	Free	Free	Free	Free	Stop	Stop
RT Channelized	-	None	-	None	-	None
Storage Length	-	-	100	-	0	-
Veh in Median Storage, #	0	-	-	0	0	-
Grade, %	0	-	-	0	0	-
Peak Hour Factor	92	92	92	92	92	92
Heavy Vehicles, %	0	0	0	0	0	0
Mvmt Flow	177	1	5	203	2	3

Major/Minor	Major1	Major2	Minor1	Minor2
Conflicting Flow All	0	0	178	89
Stage 1	-	-	-	178
Stage 2	-	-	-	112
Critical Hdwy	-	-	4.1	6.9
Critical Hdwy Stg 1	-	-	-	5.8
Critical Hdwy Stg 2	-	-	-	5.8
Follow-up Hdwy	-	-	2.2	3.3
Pot Cap-1 Maneuver	-	-	1410	958
Stage 1	-	-	-	841
Stage 2	-	-	-	906
Platoon blocked, %	-	-	-	-
Mov Cap-1 Maneuver	-	-	1410	958
Mov Cap-2 Maneuver	-	-	-	680
Stage 1	-	-	-	841
Stage 2	-	-	-	902

Approach	EB	WB	NB
HCM Control Delay, s	0	0.2	9.4
HCM LOS			A

Minor Lane/Major Mvmt	NBLn1	EBT	EBR	WBL	WBT
Capacity (veh/h)	823	-	-	1410	-
HCM Lane V/C Ratio	0.007	-	-	0.004	-
HCM Control Delay (s)	9.4	-	-	7.6	-
HCM Lane LOS	A	-	-	A	-
HCM 95th %tile Q(veh)	0	-	-	0	-

Intersection						
Int Delay, s/veh	0.2					
Movement	EBT	EBR	WBL	WBT	NBL	NBR
Lane Configurations	↑↑			↑↑		↑
Traffic Vol, veh/h	165	1	0	192	0	7
Future Vol, veh/h	165	1	0	192	0	7
Conflicting Peds, #/hr	0	0	0	0	0	0
Sign Control	Free	Free	Free	Free	Stop	Stop
RT Channelized	-	None	-	None	-	None
Storage Length	-	-	-	-	-	0
Veh in Median Storage, #	0	-	-	0	0	-
Grade, %	0	-	-	0	0	-
Peak Hour Factor	92	92	92	92	92	92
Heavy Vehicles, %	0	0	0	0	0	0
Mvmt Flow	179	1	0	209	0	8

Major/Minor	Major1	Major2	Minor1		
Conflicting Flow All	0	0	-	-	90
Stage 1	-	-	-	-	-
Stage 2	-	-	-	-	-
Critical Hdwy	-	-	-	-	6.9
Critical Hdwy Stg 1	-	-	-	-	-
Critical Hdwy Stg 2	-	-	-	-	-
Follow-up Hdwy	-	-	-	-	3.3
Pot Cap-1 Maneuver	-	0	-	0	956
Stage 1	-	0	-	0	-
Stage 2	-	0	-	0	-
Platoon blocked, %	-	-	-	-	-
Mov Cap-1 Maneuver	-	-	-	-	956
Mov Cap-2 Maneuver	-	-	-	-	-
Stage 1	-	-	-	-	-
Stage 2	-	-	-	-	-

Approach	EB	WB	NB
HCM Control Delay, s	0	0	8.8
HCM LOS			A

Minor Lane/Major Mvmt	NBLn1	EBT	EBR	WBT
Capacity (veh/h)	956	-	-	-
HCM Lane V/C Ratio	0.008	-	-	-
HCM Control Delay (s)	8.8	-	-	-
HCM Lane LOS	A	-	-	-
HCM 95th %tile Q(veh)	0	-	-	-

Intersection						
Int Delay, s/veh	87.4					
Movement	EBL	EBR	NBL	NBT	SBT	SBR
Lane Configurations	Y		Y	↑	↑	
Traffic Vol, veh/h	155	94	186	1723	629	137
Future Vol, veh/h	155	94	186	1723	629	137
Conflicting Peds, #/hr	0	0	0	0	0	0
Sign Control	Stop	Stop	Free	Free	Free	Free
RT Channelized	-	None	-	None	-	None
Storage Length	0	-	200	-	-	-
Veh in Median Storage, #	2	-	-	0	0	-
Grade, %	0	-	-	0	0	-
Peak Hour Factor	86	86	86	86	86	86
Heavy Vehicles, %	0	0	0	0	0	0
Mvmt Flow	180	109	216	2003	731	159

Major/Minor	Minor2	Major1		Major2	
Conflicting Flow All	3246	811	890	0	0
Stage 1	811	-	-	-	-
Stage 2	2435	-	-	-	-
Critical Hdwy	6.4	6.2	4.1	-	-
Critical Hdwy Stg 1	5.4	-	-	-	-
Critical Hdwy Stg 2	5.4	-	-	-	-
Follow-up Hdwy	3.5	3.3	2.2	-	-
Pot Cap-1 Maneuver	~ 11	383	770	-	-
Stage 1	440	-	-	-	-
Stage 2	~ 70	-	-	-	-
Platoon blocked, %				-	-
Mov Cap-1 Maneuver	~ 8	383	770	-	-
Mov Cap-2 Maneuver	~ 65	-	-	-	-
Stage 1	316	-	-	-	-
Stage 2	~ 70	-	-	-	-

Approach	EB	NB	SB
HCM Control Delay, \$	1017.7	1.1	0
HCM LOS	F		

Minor Lane/Major Mvmt	NBL	NBT	EBLn1	SBT	SBR
Capacity (veh/h)	770	-	95	-	-
HCM Lane V/C Ratio	0.281	-	3.048	-	-
HCM Control Delay (s)	11.5	\$	1017.7	-	-
HCM Lane LOS	B	-	F	-	-
HCM 95th %tile Q(veh)	1.2	-	28.2	-	-

Notes  
 ~: Volume exceeds capacity    \$: Delay exceeds 300s    +: Computation Not Defined    \*: All major volume in platoon

Timings  
4: Temescal Canyon Rd & Trilogy Pkwy



Lane Group	EBL	EBR	NBL	NBT	SBT	SBR
Lane Configurations	↖	↗	↖	↑	↑	↗
Traffic Volume (vph)	99	72	93	1811	625	98
Future Volume (vph)	99	72	93	1811	625	98
Turn Type	Prot	Perm	Prot	NA	NA	Perm
Protected Phases	4		5	2	6	
Permitted Phases		4				6
Detector Phase	4	4	5	2	6	6
Switch Phase						
Minimum Initial (s)	10.0	10.0	5.0	10.0	10.0	10.0
Minimum Split (s)	28.8	28.8	9.6	15.4	33.4	33.4
Total Split (s)	28.8	28.8	10.0	61.2	51.2	51.2
Total Split (%)	32.0%	32.0%	11.1%	68.0%	56.9%	56.9%
Yellow Time (s)	4.8	4.8	3.6	4.4	4.4	4.4
All-Red Time (s)	1.0	1.0	1.0	1.0	1.0	1.0
Lost Time Adjust (s)	-1.8	-1.8	-0.6	-1.4	-1.4	-1.4
Total Lost Time (s)	4.0	4.0	4.0	4.0	4.0	4.0
Lead/Lag			Lead		Lag	Lag
Lead-Lag Optimize?			Yes		Yes	Yes
Recall Mode	None	None	None	None	None	None

Intersection Summary

Cycle Length: 90  
 Actuated Cycle Length: 76.6  
 Natural Cycle: 120  
 Control Type: Actuated-Uncoordinated

Splits and Phases: 4: Temescal Canyon Rd & Trilogy Pkwy

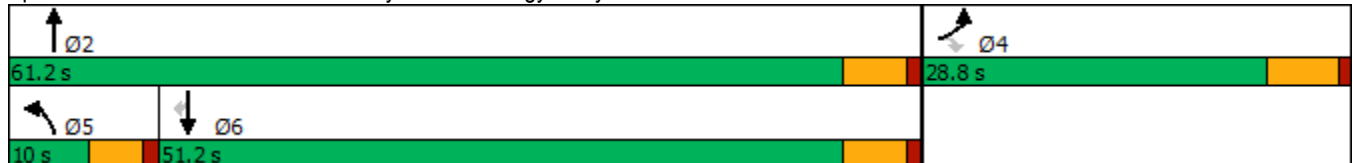

HCM 6th Signalized Intersection Summary  
4: Temescal Canyon Rd & Trilogy Pkwy

Glen Ivy Senior Living (JN 13030)  
09/11/2020



Movement	EBL	EBR	NBL	NBT	SBT	SBR
Lane Configurations						
Traffic Volume (veh/h)	99	72	93	1811	625	98
Future Volume (veh/h)	99	72	93	1811	625	98
Initial Q (Qb), veh	0	0	0	0	0	0
Ped-Bike Adj(A_pbT)	1.00	1.00	1.00			1.00
Parking Bus, Adj	1.00	1.00	1.00	1.00	1.00	1.00
Work Zone On Approach	No			No	No	
Adj Sat Flow, veh/h/ln	1900	1900	1900	1900	1900	1900
Adj Flow Rate, veh/h	101	61	95	1848	638	98
Peak Hour Factor	0.98	0.98	0.98	0.98	0.98	0.98
Percent Heavy Veh, %	0	0	0	0	0	0
Cap, veh/h	271	241	136	1417	1176	996
Arrive On Green	0.15	0.15	0.07	0.75	0.62	0.62
Sat Flow, veh/h	1810	1610	1810	1900	1900	1610
Grp Volume(v), veh/h	101	61	95	1848	638	98
Grp Sat Flow(s),veh/h/ln	1810	1610	1810	1900	1900	1610
Q Serve(g_s), s	3.9	2.6	3.9	57.2	14.8	1.9
Cycle Q Clear(g_c), s	3.9	2.6	3.9	57.2	14.8	1.9
Prop In Lane	1.00	1.00	1.00			1.00
Lane Grp Cap(c), veh/h	271	241	136	1417	1176	996
V/C Ratio(X)	0.37	0.25	0.70	1.30	0.54	0.10
Avail Cap(c_a), veh/h	585	521	142	1417	1176	996
HCM Platoon Ratio	1.00	1.00	1.00	1.00	1.00	1.00
Upstream Filter(I)	1.00	1.00	1.00	1.00	1.00	1.00
Uniform Delay (d), s/veh	29.4	28.8	34.6	9.7	8.4	5.9
Incr Delay (d2), s/veh	0.9	0.5	11.3	142.0	0.5	0.0
Initial Q Delay(d3),s/veh	0.0	0.0	0.0	0.0	0.0	0.0
%ile BackOfQ(50%),veh/ln	1.6	2.4	2.1	67.5	4.8	0.5
Unsig. Movement Delay, s/veh						
LnGrp Delay(d),s/veh	30.2	29.4	45.9	151.8	8.9	6.0
LnGrp LOS	C	C	D	F	A	A
Approach Vol, veh/h	162			1943	736	
Approach Delay, s/veh	29.9			146.6	8.5	
Approach LOS	C			F	A	
Timer - Assigned Phs		2		4	5	6
Phs Duration (G+Y+Rc), s		61.2		15.5	9.7	51.5
Change Period (Y+Rc), s		5.4		5.8	4.6	5.4
Max Green Setting (Gmax), s		55.8		23.0	5.4	45.8
Max Q Clear Time (g_c+11), s		59.2		5.9	5.9	16.8
Green Ext Time (p_c), s		0.0		0.4	0.0	4.7
<b>Intersection Summary</b>						
HCM 6th Ctrl Delay			104.2			
HCM 6th LOS			F			



Intersection						
Int Delay, s/veh	0					
Movement	EBL	EBR	NBL	NBT	SBT	SBR
Lane Configurations		↗		↑	↘	
Traffic Vol, veh/h	0	1	0	1903	703	10
Future Vol, veh/h	0	1	0	1903	703	10
Conflicting Peds, #/hr	0	0	0	0	0	0
Sign Control	Stop	Stop	Free	Free	Free	Free
RT Channelized	-	None	-	None	-	None
Storage Length	-	0	-	-	-	-
Veh in Median Storage, #	0	-	-	0	0	-
Grade, %	0	-	-	0	0	-
Peak Hour Factor	92	92	92	92	92	92
Heavy Vehicles, %	0	0	0	0	0	0
Mvmt Flow	0	1	0	2068	764	11

Major/Minor	Minor2	Major1	Major2		
Conflicting Flow All	-	770	-	0	-
Stage 1	-	-	-	-	-
Stage 2	-	-	-	-	-
Critical Hdwy	-	6.2	-	-	-
Critical Hdwy Stg 1	-	-	-	-	-
Critical Hdwy Stg 2	-	-	-	-	-
Follow-up Hdwy	-	3.3	-	-	-
Pot Cap-1 Maneuver	0	404	0	-	-
Stage 1	0	-	0	-	-
Stage 2	0	-	0	-	-
Platoon blocked, %				-	-
Mov Cap-1 Maneuver	-	404	-	-	-
Mov Cap-2 Maneuver	-	-	-	-	-
Stage 1	-	-	-	-	-
Stage 2	-	-	-	-	-

Approach	EB	NB	SB
HCM Control Delay, s	13.9	0	0
HCM LOS	B		

Minor Lane/Major Mvmt	NBT EBLn1	SBT	SBR
Capacity (veh/h)	- 404	-	-
HCM Lane V/C Ratio	- 0.003	-	-
HCM Control Delay (s)	- 13.9	-	-
HCM Lane LOS	- B	-	-
HCM 95th %tile Q(veh)	- 0	-	-

Intersection						
Int Delay, s/veh	0.5					
Movement	EBL	EBR	NBL	NBT	SBT	SBR
Lane Configurations	Y		Y	↑	↑	
Traffic Vol, veh/h	5	3	4	1899	701	4
Future Vol, veh/h	5	3	4	1899	701	4
Conflicting Peds, #/hr	0	0	0	0	0	0
Sign Control	Stop	Stop	Free	Free	Free	Free
RT Channelized	-	None	-	None	-	None
Storage Length	0	-	100	-	-	-
Veh in Median Storage, #	0	-	-	0	0	-
Grade, %	0	-	-	0	0	-
Peak Hour Factor	92	92	92	92	92	92
Heavy Vehicles, %	0	0	0	0	0	0
Mvmt Flow	5	3	4	2064	762	4

Major/Minor	Minor2	Major1	Major2			
Conflicting Flow All	2836	764	766	0	-	0
Stage 1	764	-	-	-	-	-
Stage 2	2072	-	-	-	-	-
Critical Hdwy	6.4	6.2	4.1	-	-	-
Critical Hdwy Stg 1	5.4	-	-	-	-	-
Critical Hdwy Stg 2	5.4	-	-	-	-	-
Follow-up Hdwy	3.5	3.3	2.2	-	-	-
Pot Cap-1 Maneuver	20	407	856	-	-	-
Stage 1	463	-	-	-	-	-
Stage 2	107	-	-	-	-	-
Platoon blocked, %				-	-	-
Mov Cap-1 Maneuver	20	407	856	-	-	-
Mov Cap-2 Maneuver	20	-	-	-	-	-
Stage 1	461	-	-	-	-	-
Stage 2	107	-	-	-	-	-

Approach	EB	NB	SB
HCM Control Delay, s	161.4	0	0
HCM LOS	F		

Minor Lane/Major Mvmt	NBL	NBT	EBLn1	SBT	SBR
Capacity (veh/h)	856	-	31	-	-
HCM Lane V/C Ratio	0.005	-	0.281	-	-
HCM Control Delay (s)	9.2	-	161.4	-	-
HCM Lane LOS	A	-	F	-	-
HCM 95th %tile Q(veh)	0	-	0.9	-	-

Intersection						
Int Delay, s/veh	0.2					
Movement	EBT	EBR	WBL	WBT	NBL	NBR
Lane Configurations	↑↑		↖	↑↑	↘	
Traffic Vol, veh/h	353	1	5	259	4	5
Future Vol, veh/h	353	1	5	259	4	5
Conflicting Peds, #/hr	0	0	0	0	0	0
Sign Control	Free	Free	Free	Free	Stop	Stop
RT Channelized	-	None	-	None	-	None
Storage Length	-	-	100	-	0	-
Veh in Median Storage, #	0	-	-	0	0	-
Grade, %	0	-	-	0	0	-
Peak Hour Factor	92	92	92	92	92	92
Heavy Vehicles, %	0	0	0	0	0	0
Mvmt Flow	384	1	5	282	4	5

Major/Minor	Major1	Major2	Minor1		
Conflicting Flow All	0	0	385	0	536 193
Stage 1	-	-	-	-	385 -
Stage 2	-	-	-	-	151 -
Critical Hdwy	-	-	4.1	-	6.8 6.9
Critical Hdwy Stg 1	-	-	-	-	5.8 -
Critical Hdwy Stg 2	-	-	-	-	5.8 -
Follow-up Hdwy	-	-	2.2	-	3.5 3.3
Pot Cap-1 Maneuver	-	-	1185	-	480 822
Stage 1	-	-	-	-	663 -
Stage 2	-	-	-	-	867 -
Platoon blocked, %	-	-	-	-	-
Mov Cap-1 Maneuver	-	-	1185	-	478 822
Mov Cap-2 Maneuver	-	-	-	-	478 -
Stage 1	-	-	-	-	663 -
Stage 2	-	-	-	-	864 -

Approach	EB	WB	NB
HCM Control Delay, s	0	0.2	10.9
HCM LOS			B

Minor Lane/Major Mvmt	NBLn1	EBT	EBR	WBL	WBT
Capacity (veh/h)	623	-	-	1185	-
HCM Lane V/C Ratio	0.016	-	-	0.005	-
HCM Control Delay (s)	10.9	-	-	8.1	-
HCM Lane LOS	B	-	-	A	-
HCM 95th %tile Q(veh)	0	-	-	0	-

Intersection						
Int Delay, s/veh	0.2					
Movement	EBT	EBR	WBL	WBT	NBL	NBR
Lane Configurations	↑↑			↑↑		↑
Traffic Vol, veh/h	357	1	0	264	0	13
Future Vol, veh/h	357	1	0	264	0	13
Conflicting Peds, #/hr	0	0	0	0	0	0
Sign Control	Free	Free	Free	Free	Stop	Stop
RT Channelized	-	None	-	None	-	None
Storage Length	-	-	-	-	-	0
Veh in Median Storage, #	0	-	-	0	0	-
Grade, %	0	-	-	0	0	-
Peak Hour Factor	92	92	92	92	92	92
Heavy Vehicles, %	0	0	0	0	0	0
Mvmt Flow	388	1	0	287	0	14

Major/Minor	Major1	Major2	Minor1			
Conflicting Flow All	0	0	-	-	-	195
Stage 1	-	-	-	-	-	-
Stage 2	-	-	-	-	-	-
Critical Hdwy	-	-	-	-	-	6.9
Critical Hdwy Stg 1	-	-	-	-	-	-
Critical Hdwy Stg 2	-	-	-	-	-	-
Follow-up Hdwy	-	-	-	-	-	3.3
Pot Cap-1 Maneuver	-	-	0	-	0	820
Stage 1	-	-	0	-	0	-
Stage 2	-	-	0	-	0	-
Platoon blocked, %	-	-	-	-	-	-
Mov Cap-1 Maneuver	-	-	-	-	-	820
Mov Cap-2 Maneuver	-	-	-	-	-	-
Stage 1	-	-	-	-	-	-
Stage 2	-	-	-	-	-	-

Approach	EB	WB	NB
HCM Control Delay, s	0	0	9.5
HCM LOS			A

Minor Lane/Major Mvmt	NBLn1	EBT	EBR	WBT
Capacity (veh/h)	820	-	-	-
HCM Lane V/C Ratio	0.017	-	-	-
HCM Control Delay (s)	9.5	-	-	-
HCM Lane LOS	A	-	-	-
HCM 95th %tile Q(veh)	0.1	-	-	-

Intersection						
Int Delay, s/veh	122.2					
Movement	EBL	EBR	NBL	NBT	SBT	SBR
Lane Configurations	Y		Y	↑	↑	
Traffic Vol, veh/h	294	114	137	797	1013	340
Future Vol, veh/h	294	114	137	797	1013	340
Conflicting Peds, #/hr	0	0	0	0	0	0
Sign Control	Stop	Stop	Free	Free	Free	Free
RT Channelized	-	None	-	None	-	None
Storage Length	0	-	200	-	-	-
Veh in Median Storage, #	2	-	-	0	0	-
Grade, %	0	-	-	0	0	-
Peak Hour Factor	94	94	94	94	94	94
Heavy Vehicles, %	0	0	0	0	0	0
Mvmt Flow	313	121	146	848	1078	362

Major/Minor	Minor2	Major1	Major2			
Conflicting Flow All	2399	1259	1440	0	-	0
Stage 1	1259	-	-	-	-	-
Stage 2	1140	-	-	-	-	-
Critical Hdwy	6.4	6.2	4.1	-	-	-
Critical Hdwy Stg 1	5.4	-	-	-	-	-
Critical Hdwy Stg 2	5.4	-	-	-	-	-
Follow-up Hdwy	3.5	3.3	2.2	-	-	-
Pot Cap-1 Maneuver	~ 37	210	477	-	-	-
Stage 1	~ 270	-	-	-	-	-
Stage 2	~ 308	-	-	-	-	-
Platoon blocked, %				-	-	-
Mov Cap-1 Maneuver	~ 26	210	477	-	-	-
Mov Cap-2 Maneuver	~ 151	-	-	-	-	-
Stage 1	~ 187	-	-	-	-	-
Stage 2	~ 308	-	-	-	-	-

Approach	EB	NB	SB
HCM Control Delay, s	\$ 801.7	2.3	0
HCM LOS	F		

Minor Lane/Major Mvmt	NBL	NBT	EBLn1	SBT	SBR
Capacity (veh/h)	477	-	164	-	-
HCM Lane V/C Ratio	0.306	-	2.647	-	-
HCM Control Delay (s)	15.8	-	\$ 801.7	-	-
HCM Lane LOS	C	-	F	-	-
HCM 95th %tile Q(veh)	1.3	-	38	-	-

Notes  
 ~: Volume exceeds capacity    \$: Delay exceeds 300s    +: Computation Not Defined    \*: All major volume in platoon



Timings  
4: Temescal Canyon Rd & Trilogy Pkwy



Lane Group	EBL	EBR	NBL	NBT	SBT	SBR
Lane Configurations	↖	↖	↖	↑	↑	↖
Traffic Volume (vph)	263	105	105	671	967	160
Future Volume (vph)	263	105	105	671	967	160
Turn Type	Prot	Perm	Prot	NA	NA	Perm
Protected Phases	4		5	2	6	
Permitted Phases		4				6
Detector Phase	4	4	5	2	6	6
Switch Phase						
Minimum Initial (s)	10.0	10.0	5.0	10.0	10.0	10.0
Minimum Split (s)	28.8	28.8	9.6	15.4	33.4	33.4
Total Split (s)	31.0	31.0	11.0	59.0	48.0	48.0
Total Split (%)	34.4%	34.4%	12.2%	65.6%	53.3%	53.3%
Yellow Time (s)	4.8	4.8	3.6	4.4	4.4	4.4
All-Red Time (s)	1.0	1.0	1.0	1.0	1.0	1.0
Lost Time Adjust (s)	-1.8	-1.8	-0.6	-1.4	-1.4	-1.4
Total Lost Time (s)	4.0	4.0	4.0	4.0	4.0	4.0
Lead/Lag			Lead		Lag	Lag
Lead-Lag Optimize?			Yes		Yes	Yes
Recall Mode	None	None	None	None	None	None

Intersection Summary

Cycle Length: 90  
 Actuated Cycle Length: 82.6  
 Natural Cycle: 90  
 Control Type: Actuated-Uncoordinated

Splits and Phases: 4: Temescal Canyon Rd & Trilogy Pkwy

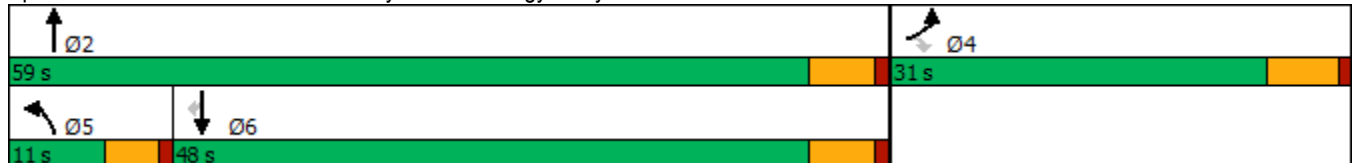

HCM 6th Signalized Intersection Summary  
4: Temescal Canyon Rd & Trilogy Pkwy

Glen Ivy Senior Living (JN 13030)  
09/11/2020



Movement	EBL	EBR	NBL	NBT	SBT	SBR
Lane Configurations						
Traffic Volume (veh/h)	263	105	105	671	967	160
Future Volume (veh/h)	263	105	105	671	967	160
Initial Q (Qb), veh	0	0	0	0	0	0
Ped-Bike Adj(A_pbT)	1.00	1.00	1.00			0.98
Parking Bus, Adj	1.00	1.00	1.00	1.00	1.00	1.00
Work Zone On Approach	No			No	No	
Adj Sat Flow, veh/h/ln	1900	1900	1900	1900	1900	1900
Adj Flow Rate, veh/h	274	93	109	699	1007	155
Peak Hour Factor	0.96	0.96	0.96	0.96	0.96	0.96
Percent Heavy Veh, %	0	0	0	0	0	0
Cap, veh/h	366	326	152	1320	1062	881
Arrive On Green	0.20	0.20	0.08	0.69	0.56	0.56
Sat Flow, veh/h	1810	1610	1810	1900	1900	1577
Grp Volume(v), veh/h	274	93	109	699	1007	155
Grp Sat Flow(s),veh/h/ln	1810	1610	1810	1900	1900	1577
Q Serve(g_s), s	11.1	3.8	4.6	13.8	38.6	3.7
Cycle Q Clear(g_c), s	11.1	3.8	4.6	13.8	38.6	3.7
Prop In Lane	1.00	1.00	1.00			1.00
Lane Grp Cap(c), veh/h	366	326	152	1320	1062	881
V/C Ratio(X)	0.75	0.29	0.72	0.53	0.95	0.18
Avail Cap(c_a), veh/h	629	560	163	1346	1077	894
HCM Platoon Ratio	1.00	1.00	1.00	1.00	1.00	1.00
Upstream Filter(I)	1.00	1.00	1.00	1.00	1.00	1.00
Uniform Delay (d), s/veh	29.1	26.2	34.6	5.7	16.1	8.4
Incr Delay (d2), s/veh	3.1	0.5	10.7	0.4	16.4	0.1
Initial Q Delay(d3),s/veh	0.0	0.0	0.0	0.0	0.0	0.0
%ile BackOfQ(50%),veh/ln	4.7	0.0	2.4	3.7	18.1	1.1
Unsig. Movement Delay, s/veh						
LnGrp Delay(d),s/veh	32.2	26.7	45.3	6.1	32.4	8.5
LnGrp LOS	C	C	D	A	C	A
Approach Vol, veh/h	367			808	1162	
Approach Delay, s/veh	30.8			11.4	29.2	
Approach LOS	C			B	C	
Timer - Assigned Phs		2		4	5	6
Phs Duration (G+Y+Rc), s		57.9		19.7	10.5	47.4
Change Period (Y+Rc), s		5.4		5.8	4.6	5.4
Max Green Setting (Gmax), s		53.6		25.2	6.4	42.6
Max Q Clear Time (g_c+11), s		15.8		13.1	6.6	40.6
Green Ext Time (p_c), s		5.2		0.9	0.0	1.4
<b>Intersection Summary</b>						
HCM 6th Ctrl Delay			23.3			
HCM 6th LOS			C			

Intersection						
Int Delay, s/veh	0					
Movement	EBL	EBR	NBL	NBT	SBT	SBR
Lane Configurations		↗		↑	↘	
Traffic Vol, veh/h	0	3	0	776	1078	11
Future Vol, veh/h	0	3	0	776	1078	11
Conflicting Peds, #/hr	0	0	0	0	0	0
Sign Control	Stop	Stop	Free	Free	Free	Free
RT Channelized	-	None	-	None	-	None
Storage Length	-	0	-	-	-	-
Veh in Median Storage, #	0	-	-	0	0	-
Grade, %	0	-	-	0	0	-
Peak Hour Factor	92	92	92	92	92	92
Heavy Vehicles, %	0	0	0	0	0	0
Mvmt Flow	0	3	0	843	1172	12

Major/Minor	Minor2	Major1	Major2		
Conflicting Flow All	-	1178	-	0	-
Stage 1	-	-	-	-	-
Stage 2	-	-	-	-	-
Critical Hdwy	-	6.2	-	-	-
Critical Hdwy Stg 1	-	-	-	-	-
Critical Hdwy Stg 2	-	-	-	-	-
Follow-up Hdwy	-	3.3	-	-	-
Pot Cap-1 Maneuver	0	235	0	-	-
Stage 1	0	-	0	-	-
Stage 2	0	-	0	-	-
Platoon blocked, %				-	-
Mov Cap-1 Maneuver	-	235	-	-	-
Mov Cap-2 Maneuver	-	-	-	-	-
Stage 1	-	-	-	-	-
Stage 2	-	-	-	-	-

Approach	EB	NB	SB
HCM Control Delay, s	20.5	0	0
HCM LOS	C		

Minor Lane/Major Mvmt	NBT	EBLn1	SBT	SBR
Capacity (veh/h)	-	235	-	-
HCM Lane V/C Ratio	-	0.014	-	-
HCM Control Delay (s)	-	20.5	-	-
HCM Lane LOS	-	C	-	-
HCM 95th %tile Q(veh)	-	0	-	-

Intersection						
Int Delay, s/veh	0.4					
Movement	EBL	EBR	NBL	NBT	SBT	SBR
Lane Configurations	Y		Y	↑	↑	
Traffic Vol, veh/h	8	5	4	768	1076	4
Future Vol, veh/h	8	5	4	768	1076	4
Conflicting Peds, #/hr	0	0	0	0	0	0
Sign Control	Stop	Stop	Free	Free	Free	Free
RT Channelized	-	None	-	None	-	None
Storage Length	0	-	100	-	-	-
Veh in Median Storage, #	0	-	-	0	0	-
Grade, %	0	-	-	0	0	-
Peak Hour Factor	92	92	92	92	92	92
Heavy Vehicles, %	0	0	0	0	0	0
Mvmt Flow	9	5	4	835	1170	4

Major/Minor	Minor2	Major1	Major2			
Conflicting Flow All	2015	1172	1174	0	-	0
Stage 1	1172	-	-	-	-	-
Stage 2	843	-	-	-	-	-
Critical Hdwy	6.4	6.2	4.1	-	-	-
Critical Hdwy Stg 1	5.4	-	-	-	-	-
Critical Hdwy Stg 2	5.4	-	-	-	-	-
Follow-up Hdwy	3.5	3.3	2.2	-	-	-
Pot Cap-1 Maneuver	65	236	602	-	-	-
Stage 1	297	-	-	-	-	-
Stage 2	426	-	-	-	-	-
Platoon blocked, %				-	-	-
Mov Cap-1 Maneuver	65	236	602	-	-	-
Mov Cap-2 Maneuver	65	-	-	-	-	-
Stage 1	295	-	-	-	-	-
Stage 2	426	-	-	-	-	-

Approach	EB	NB	SB
HCM Control Delay, s	52.3	0.1	0
HCM LOS	F		

Minor Lane/Major Mvmt	NBL	NBT	EBLn1	SBT	SBR
Capacity (veh/h)	602	-	90	-	-
HCM Lane V/C Ratio	0.007	-	0.157	-	-
HCM Control Delay (s)	11	-	52.3	-	-
HCM Lane LOS	B	-	F	-	-
HCM 95th %tile Q(veh)	0	-	0.5	-	-

**APPENDIX 7.4:**

**HORIZON YEAR (2040) WITH PROJECT CONDITIONS TRAFFIC SIGNAL WARRANT  
ANALYSIS WORKSHEETS**

This Page Intentionally Left Blank



### Figure 4C-103 (CA). Traffic Signal Warrants Worksheet (Average Traffic Estimate Form)

<u>DIST</u>	<u>CO</u>	<u>RTE</u>	<u>PM</u>	TRAFFIC CONDITIONS	<b>2040 WP</b>
Jurisdiction: <u>County of Riverside</u>				CALC <u>CS</u>	DATE <u>09/03/20</u>
Major Street: <u>Trilogy Pkwy.</u>				CHK <u>CS</u>	DATE <u>09/03/20</u>
Minor Street: <u>Driveway 1</u>				Critical Approach Speed (Major) <u>45</u> mph	
				Critical Approach Speed (Minor) <u>25</u> mph	
Major Street Approach Lanes = <u>1</u>	lane	Minor Street Approach Lanes = <u>1</u>	lane		
Major Street Future ADT = <u>8,881</u>	vpd	Minor Street Future ADT = <u>134</u>	vpd		
Speed limit or critical speed on major street traffic > 64 km/h (40 mph); .....	<input checked="" type="checkbox"/>	or	<input type="checkbox"/>		<b>RURAL (R)</b>
In built up area of isolated community of < 10,000 population .....	<input type="checkbox"/>				

**(Based on Estimated Average Daily Traffic - See Note)**

<u>URBAN</u>	<u>RURAL</u>	Minimum Requirements EADT			
<b>CONDITION A - Minimum Vehicular Volume</b>		Vehicles Per Day on Major Street (Total of Both Approaches)		Vehicles Per Day on Higher-Volume Minor Street Approach (One Direction Only)	
<u>Satisfied</u>	<u>Not Satisfied</u>	<u>Urban</u>	<u>Rural</u>	<u>Urban</u>	<u>Rural</u>
	<b>XX</b>				
Number of lanes for moving traffic on each approach					
<u>Major Street</u>	<u>Minor Street</u>				
1 <b>8,881</b>	1 <b>134</b>	8,000	5,600 *	2,400	1,680
2 +	1	9,600	6,720	2,400	1,680
2 +	2 +	9,600	6,720	3,200	2,240
1	2 +	8,000	5,600	3,200	2,240
<b>CONDITION B - Interruption of Continuous Traffic</b>		Vehicles Per Day on Major Street (Total of Both Approaches)		Vehicles Per Day on Higher-Volume Minor Street Approach (One Direction Only)	
<u>Satisfied</u>	<u>Not Satisfied</u>	<u>Urban</u>	<u>Rural</u>	<u>Urban</u>	<u>Rural</u>
	<b>XX</b>				
Number of lanes for moving traffic on each approach					
<u>Major Street</u>	<u>Minor Street</u>				
1 <b>8,881</b>	1 <b>134</b>	12,000	8,400 *	1,200	850
2 +	1	14,400	10,080	1,200	850
2 +	2 +	14,400	10,080	1,600	1,120
1	2 +	12,000	8,400	1,600	1,120
<b>Combination of CONDITIONS A + B</b>		2 CONDITIONS 80%		2 CONDITIONS 80%	
<u>Satisfied</u>	<u>Not Satisfied</u>				
	<b>XX</b>				
No one condition satisfied, but following conditions fulfilled 80% of more .....					
	<b>A</b>				
	<b>8%</b>				
	<b>B</b>				
	<b>16%</b>				

**Note: To be used only for NEW INTERSECTIONS or other locations where it is not reasonable to count actual traffic volumes.**

The satisfaction of a traffic signal warrant or warrants shall not in itself require the installation of a traffic control signal.



### Figure 4C-103 (CA). Traffic Signal Warrants Worksheet (Average Traffic Estimate Form)

<u>DIST</u>	<u>CO</u>	<u>RTE</u>	<u>PM</u>	TRAFFIC CONDITIONS	<b>2040 WP</b>
Jurisdiction: <u>County of Riverside</u>				CALC <u>CS</u>	DATE <u>09/03/20</u>
Major Street: <u>Temescal Canyon Rd.</u>				CHK <u>CS</u>	DATE <u>09/03/20</u>
Minor Street: <u>Driveway 4</u>				Critical Approach Speed (Major) <u>40</u> mph	
				Critical Approach Speed (Minor) <u>25</u> mph	
Major Street Approach Lanes = <u>1</u>	lane	Minor Street Approach Lanes: <u>1</u>	lane		
Major Street Future ADT = <u>37,333</u>	vpd	Minor Street Future ADT = <u>117</u>	vpd		
Speed limit or critical speed on major street traffic > 64 km/h (40 mph); .....				<input type="checkbox"/>	
				or	<b>RURAL (R)</b>
In built up area of isolated community of < 10,000 population .....				<input type="checkbox"/>	

**(Based on Estimated Average Daily Traffic - See Note)**

<u>URBAN</u>	<u>RURAL</u>	Minimum Requirements EADT			
<b>XX</b>					
<b>CONDITION A - Minimum Vehicular Volume</b>		Vehicles Per Day on Major Street (Total of Both Approaches)		Vehicles Per Day on Higher-Volume Minor Street Approach (One Direction Only)	
<u>Satisfied</u>	<u>Not Satisfied</u>				
	<b>XX</b>	<u>Urban</u>	<u>Rural</u>	<u>Urban</u>	<u>Rural</u>
Number of lanes for moving traffic on each approach					
<u>Major Street</u>	<u>Minor Street</u>				
1 <b>37,333</b>	1 <b>117</b>	8,000 *	5,600	2,400	1,680
2 +	1	9,600	6,720	2,400	1,680
2 +	2 +	9,600	6,720	3,200	2,240
1	2 +	8,000	5,600	3,200	2,240
<b>CONDITION B - Interruption of Continuous Traffic</b>		Vehicles Per Day on Major Street (Total of Both Approaches)		Vehicles Per Day on Higher-Volume Minor Street Approach (One Direction Only)	
<u>Satisfied</u>	<u>Not Satisfied</u>				
	<b>XX</b>	<u>Urban</u>	<u>Rural</u>	<u>Urban</u>	<u>Rural</u>
Number of lanes for moving traffic on each approach					
<u>Major Street</u>	<u>Minor Street</u>				
1 <b>37,333</b>	1 <b>117</b>	12,000 *	8,400	1,200	850
2 +	1	14,400	10,080	1,200	850
2 +	2 +	14,400	10,080	1,600	1,120
1	2 +	12,000	8,400	1,600	1,120
<b>Combination of CONDITIONS A + B</b>		2 CONDITIONS 80%		2 CONDITIONS 80%	
<u>Satisfied</u>	<u>Not Satisfied</u>				
	<b>XX</b>				
No one condition satisfied, but following conditions fulfilled 80% of more .....					
	<u>A</u>				
	<b>5%</b>				
	<u>B</u>				
	<b>10%</b>				

**Note: To be used only for NEW INTERSECTIONS or other locations where it is not reasonable to count actual traffic volumes.**

The satisfaction of a traffic signal warrant or warrants shall not in itself require the installation of a traffic control signal.

**APPENDIX 7.5:**

**HORIZON YEAR (2040) WITH PROJECT CONDITIONS INTERSECTION OPERATIONS  
ANALYSIS WORKSHEETS WITH IMPROVEMENTS**

This Page Intentionally Left Blank

Timings  
3: Temescal Canyon Rd & Lawson Rd.



Lane Group	EBL	NBL	NBT	SBT
Lane Configurations				
Traffic Volume (vph)	155	186	1723	629
Future Volume (vph)	155	186	1723	629
Turn Type	Prot	Prot	NA	NA
Protected Phases	4	5	2	6
Permitted Phases				
Detector Phase	4	5	2	6
Switch Phase				
Minimum Initial (s)	10.0	5.0	10.0	10.0
Minimum Split (s)	28.8	9.6	15.4	33.4
Total Split (s)	30.0	22.0	60.0	38.0
Total Split (%)	33.3%	24.4%	66.7%	42.2%
Yellow Time (s)	4.8	3.6	4.4	4.4
All-Red Time (s)	1.0	1.0	1.0	1.0
Lost Time Adjust (s)	0.0	0.0	0.0	0.0
Total Lost Time (s)	5.8	4.6	5.4	5.4
Lead/Lag		Lead		Lag
Lead-Lag Optimize?		Yes		Yes
Recall Mode	None	None	None	None

Intersection Summary

Cycle Length: 90

Actuated Cycle Length: 79.6

Natural Cycle: 80

Control Type: Actuated-Uncoordinated

Splits and Phases: 3: Temescal Canyon Rd & Lawson Rd.

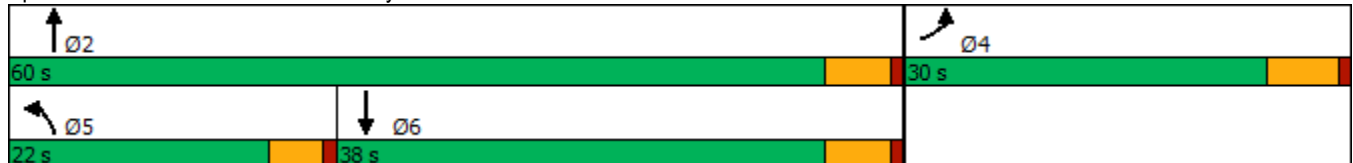

HCM 6th Signalized Intersection Summary  
 3: Temescal Canyon Rd & Lawson Rd.

Glen Ivy Senior Living (JN 13030)  
 09/11/2020



Movement	EBL	EBR	NBL	NBT	SBT	SBR
Lane Configurations						
Traffic Volume (veh/h)	155	94	186	1723	629	137
Future Volume (veh/h)	155	94	186	1723	629	137
Initial Q (Qb), veh	0	0	0	0	0	0
Ped-Bike Adj(A_pbT)	1.00	1.00	1.00			1.00
Parking Bus, Adj	1.00	1.00	1.00	1.00	1.00	1.00
Work Zone On Approach	No			No	No	
Adj Sat Flow, veh/h/ln	1900	1900	1900	1900	1900	1900
Adj Flow Rate, veh/h	180	109	216	2003	731	159
Peak Hour Factor	0.86	0.86	0.86	0.86	0.86	0.86
Percent Heavy Veh, %	0	0	0	0	0	0
Cap, veh/h	211	128	259	2365	1329	289
Arrive On Green	0.20	0.20	0.14	0.66	0.45	0.45
Sat Flow, veh/h	1073	650	1810	3705	3043	641
Grp Volume(v), veh/h	290	0	216	2003	447	443
Grp Sat Flow(s),veh/h/ln	1729	0	1810	1805	1805	1785
Q Serve(g_s), s	12.2	0.0	8.7	32.4	13.6	13.6
Cycle Q Clear(g_c), s	12.2	0.0	8.7	32.4	13.6	13.6
Prop In Lane	0.62	0.38	1.00			0.36
Lane Grp Cap(c), veh/h	339	0	259	2365	814	805
V/C Ratio(X)	0.85	0.00	0.83	0.85	0.55	0.55
Avail Cap(c_a), veh/h	556	0	418	2616	814	805
HCM Platoon Ratio	1.00	1.00	1.00	1.00	1.00	1.00
Upstream Filter(I)	1.00	0.00	1.00	1.00	1.00	1.00
Uniform Delay (d), s/veh	29.2	0.0	31.4	10.1	15.1	15.1
Incr Delay (d2), s/veh	7.1	0.0	3.7	2.6	0.8	0.8
Initial Q Delay(d3),s/veh	0.0	0.0	0.0	0.0	0.0	0.0
%ile BackOfQ(50%),veh/ln	5.3	0.0	3.8	9.6	5.0	5.0
Unsig. Movement Delay, s/veh						
LnGrp Delay(d),s/veh	36.3	0.0	35.1	12.6	15.9	15.9
LnGrp LOS	D	A	D	B	B	B
Approach Vol, veh/h	290			2219	890	
Approach Delay, s/veh	36.3			14.8	15.9	
Approach LOS	D			B	B	
Timer - Assigned Phs		2		4	5	6
Phs Duration (G+Y+Rc), s		54.8		20.6	15.4	39.4
Change Period (Y+Rc), s		5.4		5.8	4.6	5.4
Max Green Setting (Gmax), s		54.6		24.2	17.4	32.6
Max Q Clear Time (g_c+11), s		34.4		14.2	10.7	15.6
Green Ext Time (p_c), s		15.0		0.6	0.2	5.0
<b>Intersection Summary</b>						
HCM 6th Ctrl Delay			16.9			
HCM 6th LOS			B			



Timings  
4: Temescal Canyon Rd & Trilogy Pkwy



Lane Group	EBL	EBR	NBL	NBT	SBT	SBR
Lane Configurations	↖	↗	↖	↑↑	↑↑	↗
Traffic Volume (vph)	99	72	93	1811	625	98
Future Volume (vph)	99	72	93	1811	625	98
Turn Type	Prot	Perm	Prot	NA	NA	Perm
Protected Phases	4		5	2	6	
Permitted Phases		4				6
Detector Phase	4	4	5	2	6	6
Switch Phase						
Minimum Initial (s)	10.0	10.0	5.0	10.0	10.0	10.0
Minimum Split (s)	28.8	28.8	9.6	15.4	33.4	33.4
Total Split (s)	28.8	28.8	14.2	61.2	47.0	47.0
Total Split (%)	32.0%	32.0%	15.8%	68.0%	52.2%	52.2%
Yellow Time (s)	4.8	4.8	3.6	4.4	4.4	4.4
All-Red Time (s)	1.0	1.0	1.0	1.0	1.0	1.0
Lost Time Adjust (s)	-1.8	-1.8	-0.6	-1.4	-1.4	-1.4
Total Lost Time (s)	4.0	4.0	4.0	4.0	4.0	4.0
Lead/Lag			Lead		Lag	Lag
Lead-Lag Optimize?			Yes		Yes	Yes
Recall Mode	None	None	None	None	None	None

Intersection Summary

Cycle Length: 90  
 Actuated Cycle Length: 63.7  
 Natural Cycle: 75  
 Control Type: Actuated-Uncoordinated

Splits and Phases: 4: Temescal Canyon Rd & Trilogy Pkwy



HCM 6th Signalized Intersection Summary  
4: Temescal Canyon Rd & Trilogy Pkwy

Glen Ivy Senior Living (JN 13030)  
09/11/2020



Movement	EBL	EBR	NBL	NBT	SBT	SBR
Lane Configurations						
Traffic Volume (veh/h)	99	72	93	1811	625	98
Future Volume (veh/h)	99	72	93	1811	625	98
Initial Q (Qb), veh	0	0	0	0	0	0
Ped-Bike Adj(A_pbT)	1.00	1.00	1.00			1.00
Parking Bus, Adj	1.00	1.00	1.00	1.00	1.00	1.00
Work Zone On Approach	No			No	No	
Adj Sat Flow, veh/h/ln	1900	1900	1900	1900	1900	1900
Adj Flow Rate, veh/h	101	61	95	1848	638	98
Peak Hour Factor	0.98	0.98	0.98	0.98	0.98	0.98
Percent Heavy Veh, %	0	0	0	0	0	0
Cap, veh/h	326	290	140	2493	1982	884
Arrive On Green	0.18	0.18	0.08	0.69	0.55	0.55
Sat Flow, veh/h	1810	1610	1810	3705	3705	1610
Grp Volume(v), veh/h	101	61	95	1848	638	98
Grp Sat Flow(s),veh/h/ln	1810	1610	1810	1805	1805	1610
Q Serve(g_s), s	3.0	2.0	3.2	20.1	6.0	1.8
Cycle Q Clear(g_c), s	3.0	2.0	3.2	20.1	6.0	1.8
Prop In Lane	1.00	1.00	1.00			1.00
Lane Grp Cap(c), veh/h	326	290	140	2493	1982	884
V/C Ratio(X)	0.31	0.21	0.68	0.74	0.32	0.11
Avail Cap(c_a), veh/h	723	644	298	3329	2503	1116
HCM Platoon Ratio	1.00	1.00	1.00	1.00	1.00	1.00
Upstream Filter(I)	1.00	1.00	1.00	1.00	1.00	1.00
Uniform Delay (d), s/veh	22.1	21.7	27.9	6.1	7.7	6.7
Incr Delay (d2), s/veh	0.5	0.4	2.2	0.6	0.1	0.1
Initial Q Delay(d3),s/veh	0.0	0.0	0.0	0.0	0.0	0.0
%ile BackOfQ(50%),veh/ln	1.2	0.0	1.3	4.0	1.7	0.5
Unsig. Movement Delay, s/veh						
LnGrp Delay(d),s/veh	22.6	22.0	30.0	6.7	7.8	6.8
LnGrp LOS	C	C	C	A	A	A
Approach Vol, veh/h	162			1943	736	
Approach Delay, s/veh	22.4			7.8	7.6	
Approach LOS	C			A	A	
Timer - Assigned Phs		2		4	5	6
Phs Duration (G+Y+Rc), s		46.8		15.2	8.8	38.0
Change Period (Y+Rc), s		5.4		5.8	4.6	5.4
Max Green Setting (Gmax), s		55.8		23.0	9.6	41.6
Max Q Clear Time (g_c+I1), s		22.1		5.0	5.2	8.0
Green Ext Time (p_c), s		19.3		0.4	0.0	4.8
<b>Intersection Summary</b>						
HCM 6th Ctrl Delay			8.6			
HCM 6th LOS			A			

Intersection						
Int Delay, s/veh	0.1					
Movement	EBL	EBR	NBL	NBT	SBT	SBR
Lane Configurations						
Traffic Vol, veh/h	5	3	4	1899	701	4
Future Vol, veh/h	5	3	4	1899	701	4
Conflicting Peds, #/hr	0	0	0	0	0	0
Sign Control	Stop	Stop	Free	Free	Free	Free
RT Channelized	-	None	-	None	-	None
Storage Length	0	-	100	-	-	-
Veh in Median Storage, #	1	-	-	0	0	-
Grade, %	0	-	-	0	0	-
Peak Hour Factor	92	92	92	92	92	92
Heavy Vehicles, %	0	0	0	0	0	0
Mvmt Flow	5	3	4	2064	762	4

Major/Minor	Minor2	Major1	Major2			
Conflicting Flow All	1804	383	766	0	-	0
Stage 1	764	-	-	-	-	-
Stage 2	1040	-	-	-	-	-
Critical Hdwy	6.8	6.9	4.1	-	-	-
Critical Hdwy Stg 1	5.8	-	-	-	-	-
Critical Hdwy Stg 2	5.8	-	-	-	-	-
Follow-up Hdwy	3.5	3.3	2.2	-	-	-
Pot Cap-1 Maneuver	72	621	856	-	-	-
Stage 1	426	-	-	-	-	-
Stage 2	306	-	-	-	-	-
Platoon blocked, %				-	-	-
Mov Cap-1 Maneuver	72	621	856	-	-	-
Mov Cap-2 Maneuver	194	-	-	-	-	-
Stage 1	424	-	-	-	-	-
Stage 2	306	-	-	-	-	-

Approach	EB	NB	SB
HCM Control Delay, s	19.3	0	0
HCM LOS	C		

Minor Lane/Major Mvmt	NBL	NBT	EBLn1	SBT	SBR
Capacity (veh/h)	856	-	261	-	-
HCM Lane V/C Ratio	0.005	-	0.033	-	-
HCM Control Delay (s)	9.2	-	19.3	-	-
HCM Lane LOS	A	-	C	-	-
HCM 95th %tile Q(veh)	0	-	0.1	-	-

Timings  
4: Temescal Canyon Rd & Trilogy Pkwy



Lane Group	EBL	EBR	NBL	NBT	SBT	SBR
Lane Configurations	↖	↗	↖	↑↑	↑↑	↗
Traffic Volume (vph)	104	72	96	1806	625	98
Future Volume (vph)	104	72	96	1806	625	98
Turn Type	Prot	Perm	Prot	NA	NA	Perm
Protected Phases	4		5	2	6	
Permitted Phases		4				6
Detector Phase	4	4	5	2	6	6
Switch Phase						
Minimum Initial (s)	10.0	10.0	5.0	10.0	10.0	10.0
Minimum Split (s)	28.8	28.8	9.6	15.4	33.4	33.4
Total Split (s)	28.8	28.8	14.4	61.2	46.8	46.8
Total Split (%)	32.0%	32.0%	16.0%	68.0%	52.0%	52.0%
Yellow Time (s)	4.8	4.8	3.6	4.4	4.4	4.4
All-Red Time (s)	1.0	1.0	1.0	1.0	1.0	1.0
Lost Time Adjust (s)	-1.8	-1.8	-0.6	-1.4	-1.4	-1.4
Total Lost Time (s)	4.0	4.0	4.0	4.0	4.0	4.0
Lead/Lag			Lead		Lag	Lag
Lead-Lag Optimize?			Yes		Yes	Yes
Recall Mode	None	None	None	None	None	None

Intersection Summary

Cycle Length: 90  
 Actuated Cycle Length: 63.7  
 Natural Cycle: 75  
 Control Type: Actuated-Uncoordinated

Splits and Phases: 4: Temescal Canyon Rd & Trilogy Pkwy

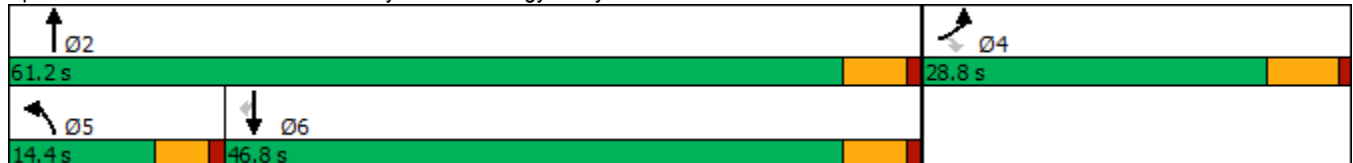

HCM 6th Signalized Intersection Summary  
4: Temescal Canyon Rd & Trilogy Pkwy

Glen Ivy Senior Living (JN 13030)  
09/11/2020



Movement	EBL	EBR	NBL	NBT	SBT	SBR
Lane Configurations						
Traffic Volume (veh/h)	104	72	96	1806	625	98
Future Volume (veh/h)	104	72	96	1806	625	98
Initial Q (Qb), veh	0	0	0	0	0	0
Ped-Bike Adj(A_pbT)	1.00	1.00	1.00			1.00
Parking Bus, Adj	1.00	1.00	1.00	1.00	1.00	1.00
Work Zone On Approach	No			No	No	
Adj Sat Flow, veh/h/ln	1900	1900	1900	1900	1900	1900
Adj Flow Rate, veh/h	106	61	98	1843	638	98
Peak Hour Factor	0.98	0.98	0.98	0.98	0.98	0.98
Percent Heavy Veh, %	0	0	0	0	0	0
Cap, veh/h	328	292	144	2489	1970	878
Arrive On Green	0.18	0.18	0.08	0.69	0.55	0.55
Sat Flow, veh/h	1810	1610	1810	3705	3705	1610
Grp Volume(v), veh/h	106	61	98	1843	638	98
Grp Sat Flow(s),veh/h/ln	1810	1610	1810	1805	1805	1610
Q Serve(g_s), s	3.2	2.0	3.3	20.1	6.0	1.8
Cycle Q Clear(g_c), s	3.2	2.0	3.3	20.1	6.0	1.8
Prop In Lane	1.00	1.00	1.00			1.00
Lane Grp Cap(c), veh/h	328	292	144	2489	1970	878
V/C Ratio(X)	0.32	0.21	0.68	0.74	0.32	0.11
Avail Cap(c_a), veh/h	724	644	304	3332	2494	1112
HCM Platoon Ratio	1.00	1.00	1.00	1.00	1.00	1.00
Upstream Filter(I)	1.00	1.00	1.00	1.00	1.00	1.00
Uniform Delay (d), s/veh	22.1	21.6	27.8	6.1	7.8	6.8
Incr Delay (d2), s/veh	0.6	0.4	2.1	0.6	0.1	0.1
Initial Q Delay(d3),s/veh	0.0	0.0	0.0	0.0	0.0	0.0
%ile BackOfQ(50%),veh/ln	1.2	1.9	1.4	4.0	1.8	0.5
Unsig. Movement Delay, s/veh						
LnGrp Delay(d),s/veh	22.6	21.9	29.9	6.7	7.9	6.9
LnGrp LOS	C	C	C	A	A	A
Approach Vol, veh/h	167			1941	736	
Approach Delay, s/veh	22.4			7.9	7.7	
Approach LOS	C			A	A	
Timer - Assigned Phs		2		4	5	6
Phs Duration (G+Y+Rc), s		46.7		15.2	8.9	37.8
Change Period (Y+Rc), s		5.4		5.8	4.6	5.4
Max Green Setting (Gmax), s		55.8		23.0	9.8	41.4
Max Q Clear Time (g_c+I1), s		22.1		5.2	5.3	8.0
Green Ext Time (p_c), s		19.3		0.4	0.0	4.8
<b>Intersection Summary</b>						
HCM 6th Ctrl Delay			8.7			
HCM 6th LOS			A			

Timings  
 3: Temescal Canyon Rd & Lawson Rd.



Lane Group	EBL	NBL	NBT	SBT
Lane Configurations				
Traffic Volume (vph)	294	137	797	1013
Future Volume (vph)	294	137	797	1013
Turn Type	Prot	Prot	NA	NA
Protected Phases	4	5	2	6
Permitted Phases				
Detector Phase	4	5	2	6
Switch Phase				
Minimum Initial (s)	10.0	5.0	10.0	10.0
Minimum Split (s)	28.8	9.6	15.4	33.4
Total Split (s)	32.0	15.0	58.0	43.0
Total Split (%)	35.6%	16.7%	64.4%	47.8%
Yellow Time (s)	4.8	3.6	4.4	4.4
All-Red Time (s)	1.0	1.0	1.0	1.0
Lost Time Adjust (s)	-1.8	-0.6	-1.4	-1.4
Total Lost Time (s)	4.0	4.0	4.0	4.0
Lead/Lag		Lead		Lag
Lead-Lag Optimize?		Yes		Yes
Recall Mode	None	None	Min	Min

Intersection Summary

Cycle Length: 90  
 Actuated Cycle Length: 85.1  
 Natural Cycle: 80  
 Control Type: Actuated-Uncoordinated

Splits and Phases: 3: Temescal Canyon Rd & Lawson Rd.

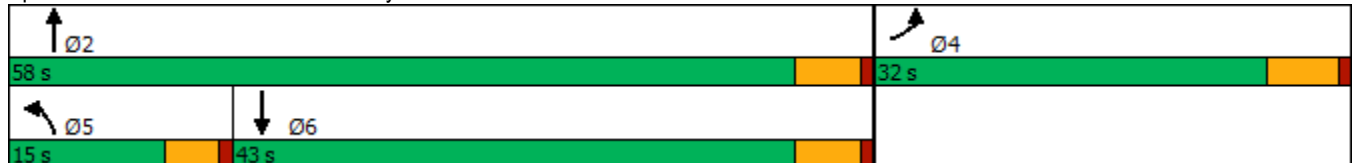



HCM 6th Signalized Intersection Summary  
 3: Temescal Canyon Rd & Lawson Rd.

Glen Ivy Senior Living (JN 13030)  
 09/11/2020



Movement	EBL	EBR	NBL	NBT	SBT	SBR
Lane Configurations						
Traffic Volume (veh/h)	294	114	137	797	1013	340
Future Volume (veh/h)	294	114	137	797	1013	340
Initial Q (Qb), veh	0	0	0	0	0	0
Ped-Bike Adj(A_pbT)	1.00	1.00	1.00			1.00
Parking Bus, Adj	1.00	1.00	1.00	1.00	1.00	1.00
Work Zone On Approach	No			No	No	
Adj Sat Flow, veh/h/ln	1900	1900	1900	1900	1900	1900
Adj Flow Rate, veh/h	313	121	146	848	1078	362
Peak Hour Factor	0.94	0.94	0.94	0.94	0.94	0.94
Percent Heavy Veh, %	0	0	0	0	0	0
Cap, veh/h	364	141	193	2214	1220	404
Arrive On Green	0.29	0.27	0.11	0.61	0.46	0.44
Sat Flow, veh/h	1259	487	1810	3705	2758	883
Grp Volume(v), veh/h	435	0	146	848	726	714
Grp Sat Flow(s),veh/h/ln	1749	0	1810	1805	1805	1741
Q Serve(g_s), s	19.4	0.0	6.5	9.8	30.1	31.1
Cycle Q Clear(g_c), s	19.4	0.0	6.5	9.8	30.1	31.1
Prop In Lane	0.72	0.28	1.00			0.51
Lane Grp Cap(c), veh/h	507	0	193	2214	827	798
V/C Ratio(X)	0.86	0.00	0.76	0.38	0.88	0.90
Avail Cap(c_a), veh/h	594	0	241	2365	854	824
HCM Platoon Ratio	1.00	1.00	1.00	1.00	1.00	1.00
Upstream Filter(I)	1.00	0.00	1.00	1.00	1.00	1.00
Uniform Delay (d), s/veh	27.9	0.0	35.8	8.1	20.2	20.9
Incr Delay (d2), s/veh	10.7	0.0	7.4	0.1	10.1	12.1
Initial Q Delay(d3),s/veh	0.0	0.0	0.0	0.0	0.0	0.0
%ile BackOfQ(50%),veh/ln	8.9	0.0	3.1	3.1	13.3	13.8
Unsig. Movement Delay, s/veh						
LnGrp Delay(d),s/veh	38.7	0.0	43.2	8.2	30.3	33.0
LnGrp LOS	D	A	D	A	C	C
Approach Vol, veh/h	435			994	1440	
Approach Delay, s/veh	38.7			13.3	31.6	
Approach LOS	D			B	C	
Timer - Assigned Phs		2		4	5	6
Phs Duration (G+Y+Rc), s		54.6		27.9	12.8	41.8
Change Period (Y+Rc), s		5.4		5.8	4.6	5.4
Max Green Setting (Gmax), s		52.6		26.2	10.4	37.6
Max Q Clear Time (g_c+1), s		11.8		21.4	8.5	33.1
Green Ext Time (p_c), s		6.6		0.7	0.0	3.2

Intersection Summary

HCM 6th Ctrl Delay	26.4
HCM 6th LOS	C

Notes

User approved volume balancing among the lanes for turning movement.

Timings  
4: Temescal Canyon Rd & Trilogy Pkwy



Lane Group	EBL	EBR	NBL	NBT	SBT	SBR
Lane Configurations	↖	↗	↖	↑↑	↑↑	↗
Traffic Volume (vph)	263	105	105	671	967	160
Future Volume (vph)	263	105	105	671	967	160
Turn Type	Prot	Perm	Prot	NA	NA	Perm
Protected Phases	4		5	2	6	
Permitted Phases		4				6
Detector Phase	4	4	5	2	6	6
Switch Phase						
Minimum Initial (s)	10.0	10.0	5.0	10.0	10.0	10.0
Minimum Split (s)	28.8	28.8	9.6	15.4	33.4	33.4
Total Split (s)	31.0	31.0	17.0	59.0	42.0	42.0
Total Split (%)	34.4%	34.4%	18.9%	65.6%	46.7%	46.7%
Yellow Time (s)	4.8	4.8	3.6	4.4	4.4	4.4
All-Red Time (s)	1.0	1.0	1.0	1.0	1.0	1.0
Lost Time Adjust (s)	-1.8	-1.8	-0.6	-1.4	-1.4	-1.4
Total Lost Time (s)	4.0	4.0	4.0	4.0	4.0	4.0
Lead/Lag			Lead		Lag	Lag
Lead-Lag Optimize?			Yes		Yes	Yes
Recall Mode	None	None	None	None	None	None

Intersection Summary

Cycle Length: 90  
 Actuated Cycle Length: 66.7  
 Natural Cycle: 75  
 Control Type: Actuated-Uncoordinated

Splits and Phases: 4: Temescal Canyon Rd & Trilogy Pkwy

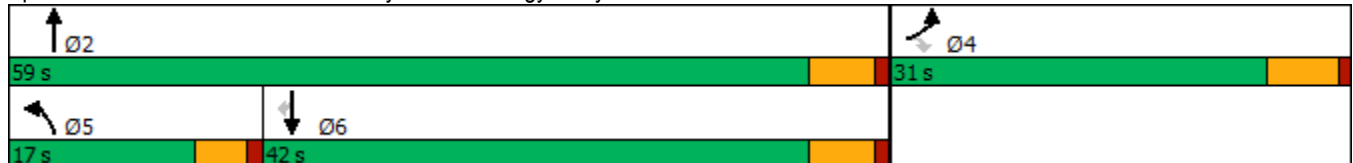

HCM 6th Signalized Intersection Summary  
 4: Temescal Canyon Rd & Trilogy Pkwy

Glen Ivy Senior Living (JN 13030)

09/11/2020



Movement	EBL	EBR	NBL	NBT	SBT	SBR
Lane Configurations						
Traffic Volume (veh/h)	263	105	105	671	967	160
Future Volume (veh/h)	263	105	105	671	967	160
Initial Q (Qb), veh	0	0	0	0	0	0
Ped-Bike Adj(A_pbT)	1.00	1.00	1.00			0.98
Parking Bus, Adj	1.00	1.00	1.00	1.00	1.00	1.00
Work Zone On Approach	No			No	No	
Adj Sat Flow, veh/h/ln	1900	1900	1900	1900	1900	1900
Adj Flow Rate, veh/h	274	93	109	699	1007	155
Peak Hour Factor	0.96	0.96	0.96	0.96	0.96	0.96
Percent Heavy Veh, %	0	0	0	0	0	0
Cap, veh/h	421	374	162	2198	1589	694
Arrive On Green	0.23	0.23	0.09	0.61	0.44	0.44
Sat Flow, veh/h	1810	1610	1810	3705	3705	1577
Grp Volume(v), veh/h	274	93	109	699	1007	155
Grp Sat Flow(s),veh/h/ln	1810	1610	1810	1805	1805	1577
Q Serve(g_s), s	6.9	2.4	2.9	4.7	10.9	3.1
Cycle Q Clear(g_c), s	6.9	2.4	2.9	4.7	10.9	3.1
Prop In Lane	1.00	1.00	1.00			1.00
Lane Grp Cap(c), veh/h	421	374	162	2198	1589	694
V/C Ratio(X)	0.65	0.25	0.67	0.32	0.63	0.22
Avail Cap(c_a), veh/h	968	861	466	3933	2717	1187
HCM Platoon Ratio	1.00	1.00	1.00	1.00	1.00	1.00
Upstream Filter(I)	1.00	1.00	1.00	1.00	1.00	1.00
Uniform Delay (d), s/veh	17.5	15.8	22.3	4.8	11.0	8.8
Incr Delay (d2), s/veh	1.7	0.3	1.8	0.1	0.4	0.2
Initial Q Delay(d3),s/veh	0.0	0.0	0.0	0.0	0.0	0.0
%ile BackOfQ(50%),veh/ln	2.5	2.3	1.2	1.0	3.3	0.8
Unsig. Movement Delay, s/veh						
LnGrp Delay(d),s/veh	19.2	16.1	24.1	4.9	11.4	8.9
LnGrp LOS	B	B	C	A	B	A
Approach Vol, veh/h	367			808	1162	
Approach Delay, s/veh	18.4			7.5	11.1	
Approach LOS	B			A	B	
Timer - Assigned Phs		2		4	5	6
Phs Duration (G+Y+Rc), s		34.7		15.7	8.5	26.2
Change Period (Y+Rc), s		5.4		5.8	4.6	5.4
Max Green Setting (Gmax), s		53.6		25.2	12.4	36.6
Max Q Clear Time (g_c+11), s		6.7		8.9	4.9	12.9
Green Ext Time (p_c), s		5.2		1.0	0.1	7.9
<b>Intersection Summary</b>						
HCM 6th Ctrl Delay			11.0			
HCM 6th LOS			B			

Intersection						
Int Delay, s/veh	0.2					
Movement	EBL	EBR	NBL	NBT	SBT	SBR
Lane Configurations	Y		Y	↑↑	↑↑	
Traffic Vol, veh/h	8	5	4	768	1076	4
Future Vol, veh/h	8	5	4	768	1076	4
Conflicting Peds, #/hr	0	0	0	0	0	0
Sign Control	Stop	Stop	Free	Free	Free	Free
RT Channelized	-	None	-	None	-	None
Storage Length	0	-	100	-	-	-
Veh in Median Storage, #	1	-	-	0	0	-
Grade, %	0	-	-	0	0	-
Peak Hour Factor	92	92	92	92	92	92
Heavy Vehicles, %	0	0	0	0	0	0
Mvmt Flow	9	5	4	835	1170	4

Major/Minor	Minor2	Major1	Major2			
Conflicting Flow All	1598	587	1174	0	-	0
Stage 1	1172	-	-	-	-	-
Stage 2	426	-	-	-	-	-
Critical Hdwy	6.8	6.9	4.1	-	-	-
Critical Hdwy Stg 1	5.8	-	-	-	-	-
Critical Hdwy Stg 2	5.8	-	-	-	-	-
Follow-up Hdwy	3.5	3.3	2.2	-	-	-
Pot Cap-1 Maneuver	99	458	602	-	-	-
Stage 1	261	-	-	-	-	-
Stage 2	632	-	-	-	-	-
Platoon blocked, %				-	-	-
Mov Cap-1 Maneuver	98	458	602	-	-	-
Mov Cap-2 Maneuver	202	-	-	-	-	-
Stage 1	259	-	-	-	-	-
Stage 2	632	-	-	-	-	-

Approach	EB	NB	SB
HCM Control Delay, s	19.8	0.1	0
HCM LOS	C		

Minor Lane/Major Mvmt	NBL	NBT	EBLn1	SBT	SBR
Capacity (veh/h)	602	-	257	-	-
HCM Lane V/C Ratio	0.007	-	0.055	-	-
HCM Control Delay (s)	11	-	19.8	-	-
HCM Lane LOS	B	-	C	-	-
HCM 95th %tile Q(veh)	0	-	0.2	-	-

Timings  
4: Temescal Canyon Rd & Trilogy Pkwy



Lane Group	EBL	EBR	NBL	NBT	SBT	SBR
Lane Configurations	↖	↗	↖	↑↑	↑↑	↗
Traffic Volume (vph)	271	105	109	663	967	160
Future Volume (vph)	271	105	109	663	967	160
Turn Type	Prot	Perm	Prot	NA	NA	Perm
Protected Phases	4		5	2	6	
Permitted Phases		4				6
Detector Phase	4	4	5	2	6	6
Switch Phase						
Minimum Initial (s)	10.0	10.0	5.0	10.0	10.0	10.0
Minimum Split (s)	28.8	28.8	9.6	15.4	33.4	33.4
Total Split (s)	31.0	31.0	17.0	59.0	42.0	42.0
Total Split (%)	34.4%	34.4%	18.9%	65.6%	46.7%	46.7%
Yellow Time (s)	4.8	4.8	3.6	4.4	4.4	4.4
All-Red Time (s)	1.0	1.0	1.0	1.0	1.0	1.0
Lost Time Adjust (s)	-1.8	-1.8	-0.6	-1.4	-1.4	-1.4
Total Lost Time (s)	4.0	4.0	4.0	4.0	4.0	4.0
Lead/Lag			Lead		Lag	Lag
Lead-Lag Optimize?			Yes		Yes	Yes
Recall Mode	None	None	None	None	None	None

Intersection Summary

Cycle Length: 90  
 Actuated Cycle Length: 67.3  
 Natural Cycle: 75  
 Control Type: Actuated-Uncoordinated

Splits and Phases: 4: Temescal Canyon Rd & Trilogy Pkwy

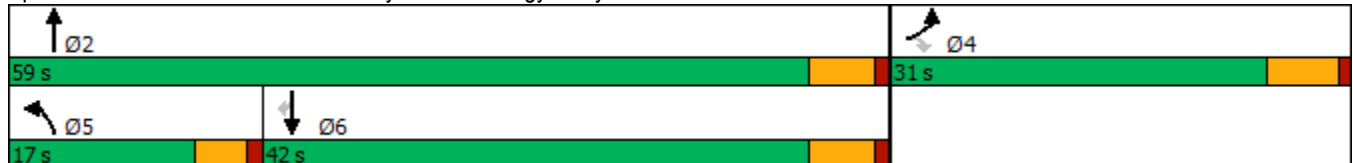

HCM 6th Signalized Intersection Summary  
 4: Temescal Canyon Rd & Trilogy Pkwy

Glen Ivy Senior Living (JN 13030)

09/11/2020



Movement	EBL	EBR	NBL	NBT	SBT	SBR
Lane Configurations						
Traffic Volume (veh/h)	271	105	109	663	967	160
Future Volume (veh/h)	271	105	109	663	967	160
Initial Q (Qb), veh	0	0	0	0	0	0
Ped-Bike Adj(A_pbT)	1.00	1.00	1.00			0.98
Parking Bus, Adj	1.00	1.00	1.00	1.00	1.00	1.00
Work Zone On Approach	No			No	No	
Adj Sat Flow, veh/h/ln	1900	1900	1900	1900	1900	1900
Adj Flow Rate, veh/h	282	93	114	691	1007	155
Peak Hour Factor	0.96	0.96	0.96	0.96	0.96	0.96
Percent Heavy Veh, %	0	0	0	0	0	0
Cap, veh/h	423	377	168	2200	1581	691
Arrive On Green	0.23	0.23	0.09	0.61	0.44	0.44
Sat Flow, veh/h	1810	1610	1810	3705	3705	1577
Grp Volume(v), veh/h	282	93	114	691	1007	155
Grp Sat Flow(s),veh/h/ln	1810	1610	1810	1805	1805	1577
Q Serve(g_s), s	7.2	2.4	3.1	4.7	11.1	3.1
Cycle Q Clear(g_c), s	7.2	2.4	3.1	4.7	11.1	3.1
Prop In Lane	1.00	1.00	1.00			1.00
Lane Grp Cap(c), veh/h	423	377	168	2200	1581	691
V/C Ratio(X)	0.67	0.25	0.68	0.31	0.64	0.22
Avail Cap(c_a), veh/h	957	851	461	3888	2686	1173
HCM Platoon Ratio	1.00	1.00	1.00	1.00	1.00	1.00
Upstream Filter(I)	1.00	1.00	1.00	1.00	1.00	1.00
Uniform Delay (d), s/veh	17.8	15.9	22.4	4.8	11.2	8.9
Incr Delay (d2), s/veh	1.8	0.3	1.8	0.1	0.4	0.2
Initial Q Delay(d3),s/veh	0.0	0.0	0.0	0.0	0.0	0.0
%ile BackOfQ(50%),veh/ln	2.7	2.4	1.2	1.0	3.3	0.8
Unsig. Movement Delay, s/veh						
LnGrp Delay(d),s/veh	19.6	16.2	24.2	4.9	11.6	9.1
LnGrp LOS	B	B	C	A	B	A
Approach Vol, veh/h	375			805	1162	
Approach Delay, s/veh	18.7			7.6	11.3	
Approach LOS	B			A	B	
Timer - Assigned Phs		2		4	5	6
Phs Duration (G+Y+Rc), s		35.1		15.9	8.8	26.4
Change Period (Y+Rc), s		5.4		5.8	4.6	5.4
Max Green Setting (Gmax), s		53.6		25.2	12.4	36.6
Max Q Clear Time (g_c+1), s		6.7		9.2	5.1	13.1
Green Ext Time (p_c), s		5.1		1.0	0.1	7.9
<b>Intersection Summary</b>						
HCM 6th Ctrl Delay			11.2			
HCM 6th LOS			B			