

Project Specific Water Quality Management Plan

A Template for Projects located within the **Santa Ana Watershed** Region of Riverside County

Project Title: TCC- KNOX VIII

Development No:

Design Review/Case No: PPT 210130

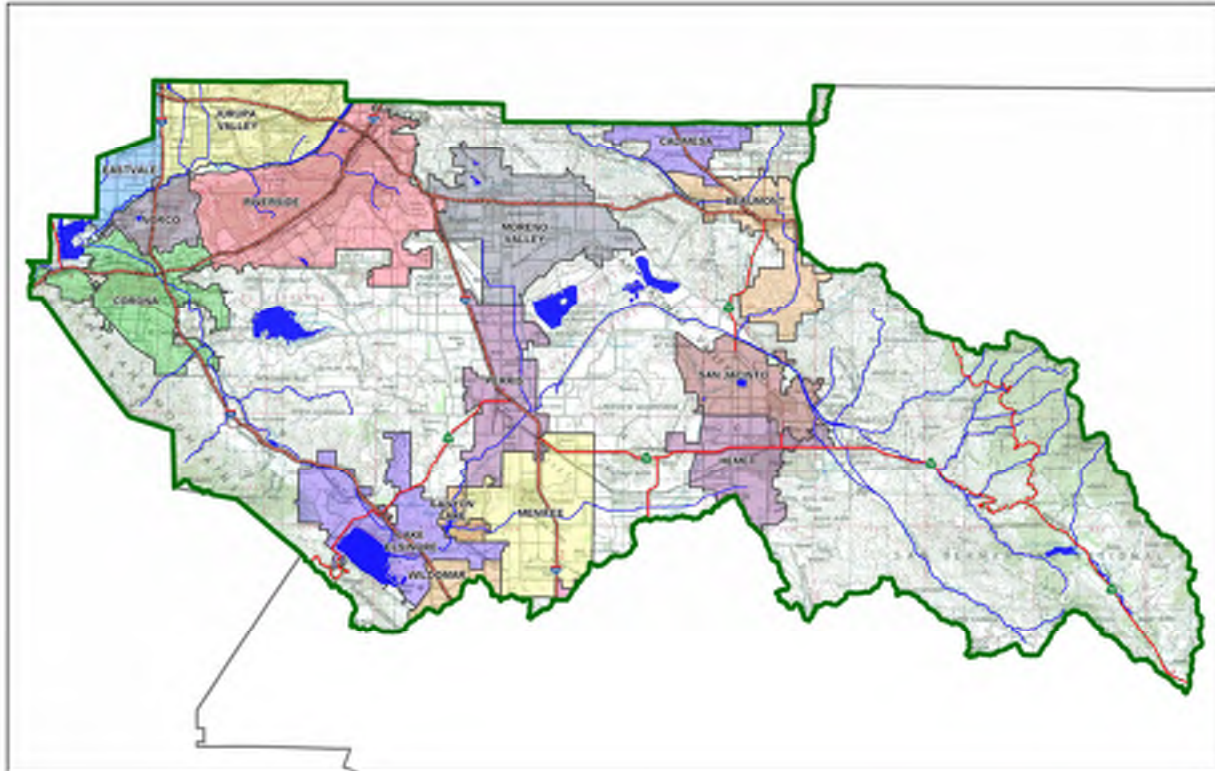

- Preliminary
- Final

Original Date Prepared: 07/01/2021

Revision Date(s): 9/10/2021,10/25/2021

*Prepared for Compliance with
Regional Board Order No. **R8-2010-0033***

Template revised June 30, 2016

Contact Information:

Prepared for:

Trammell Crow So. Cal. Development, Inc
c/o Trammell Crow Company
3501 Jamboree Road, Suite 230
Newport Beach, CA 92660
949-400-6065

Prepared by:

Huitt-Zollars, Inc.
3990 Concourse, Suite 330
Ontario, CA 91764
909-941-7799

A Brief Introduction

This Project-Specific WQMP Template for the **Santa Ana Region** has been prepared to help guide you in documenting compliance for your project. Because this document has been designed to specifically document compliance, you will need to utilize the WQMP Guidance Document as your “how-to” manual to help guide you through this process. Both the Template and Guidance Document go hand-in-hand, and will help facilitate a well prepared Project-Specific WQMP. Below is a flowchart for the layout of this Template that will provide the steps required to document compliance.

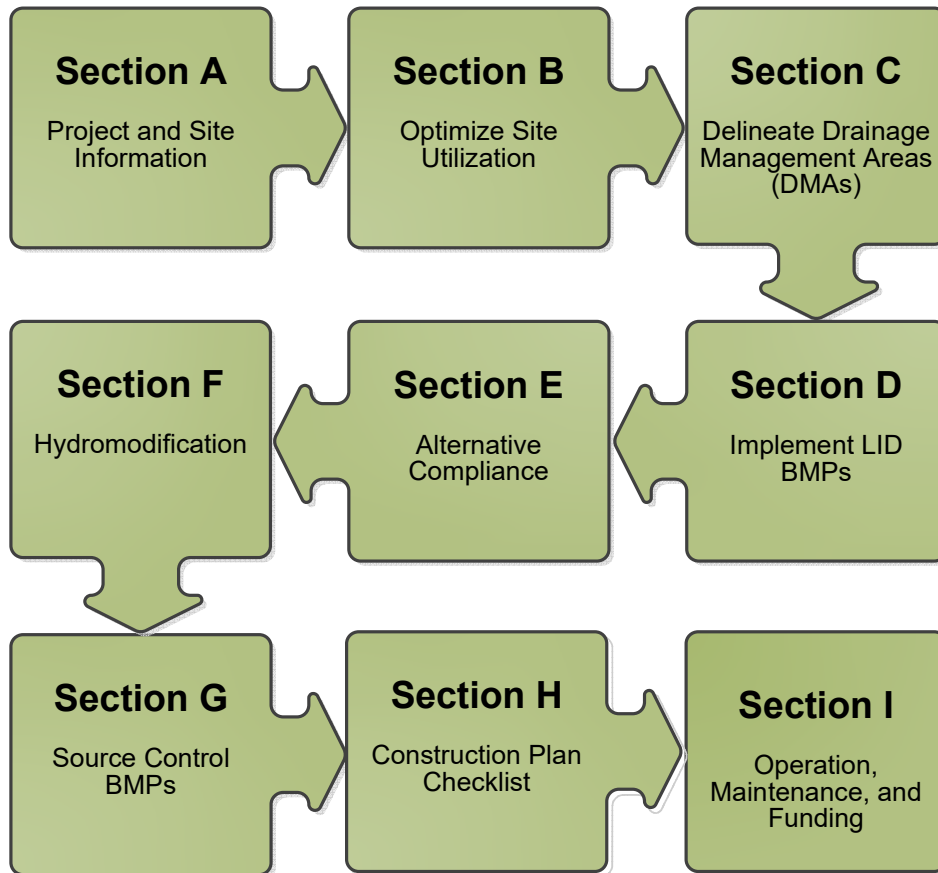

OWNER'S CERTIFICATION

This Project-Specific Water Quality Management Plan (WQMP) has been prepared for Trammell Crow So. Cal. Development, Inc, c/o Trammell Crow Company by Huitt-Zollars, inc for the TCC - KNOX VIII project (P21-0000X).

This WQMP is intended to comply with the requirements of County of Riverside for APN 295-310-016-7, 295-310-037-6, 295-310-038-7, 295-310-039-8 and 295-310-040-8 which includes the requirement for the preparation and implementation of a Project-Specific WQMP.

The undersigned, while owning the property/project described in the preceding paragraph, shall be responsible for the implementation and funding of this WQMP and will ensure that this WQMP is amended as appropriate to reflect up-to-date conditions on the site. In addition, the property owner accepts responsibility for interim operation and maintenance of Stormwater BMPs until such time as this responsibility is formally transferred to a subsequent owner. This WQMP will be reviewed with the facility operator, facility supervisors, employees, tenants, maintenance and service contractors, or any other party (or parties) having responsibility for implementing portions of this WQMP. At least one copy of this WQMP will be maintained at the project site or project office in perpetuity. The undersigned is authorized to certify and to approve implementation of this WQMP. The undersigned is aware that implementation of this WQMP is enforceable under City of Perris Water Quality Ordinance 1194 (Municipal Code Section 14.22).

"I, the undersigned, certify under penalty of law that the provisions of this WQMP have been reviewed and accepted and that the WQMP will be transferred to future successors in interest."

Owner's Signature

Dave Drake
Owner's Printed Name

Date

Executive Vice President
Owner's Title/Position

PREPARER'S CERTIFICATION

"The selection, sizing and design of stormwater treatment and other stormwater quality and quantity control measures in this plan meet the requirements of Regional Water Quality Control Board Order No. **R8-2010-0033** and any subsequent amendments thereto."

Preparer's Signature

Johnny Murad, PE
Preparer's Printed Name

Date

Vice President/Managing Principal
Preparer's Title/Position

Preparer's Licensure:

Table of Contents

Section A: Project and Site Information.....	6
A.1 Maps and Site Plans.....	6
A.2 Identify Receiving Waters.....	7
A.3 Additional Permits/Approvals required for the Project:	7
Section B: Optimize Site Utilization (LID Principles)	8
Section C: Delineate Drainage Management Areas (DMAs).....	10
Section D: Implement LID BMPs	12
D.1 Infiltration Applicability	12
D.2 Harvest and Use Assessment.....	13
D.3 Bioretention and Biotreatment Assessment	15
D.4 Feasibility Assessment Summaries	16
D.5 LID BMP Sizing	17
Section E: Alternative Compliance (LID Waiver Program)	18
E.1 Identify Pollutants of Concern	19
E.2 Stormwater Credits	20
E.3 Sizing Criteria.....	20
E.4 Treatment Control BMP Selection	21
Section F: Hydromodification	22
F.1 Hydrologic Conditions of Concern (HCOC) Analysis.....	22
F.2 HCOC Mitigation.....	23
Section G: Source Control BMPs.....	24
Section H: Construction Plan Checklist	24
Section I: Operation, Maintenance and Funding.....	27

List of Tables

Table A.1 Identification of Receiving Waters.....	7
Table A.2 Other Applicable Permits.....	7
Table C.1 DMA Classifications.....	10
Table C.2 Type 'A', Self-Treating Areas (Included with mixed DMA1 above).....	10
Table C.3 Type 'B', Self-Retaining Areas (N/A, included with mixed DMA1).....	10
Table C.4 Type 'C', Areas that Drain to Self-Retaining Areas (N/A).....	11
Table C.5 Type 'D', Areas Draining to BMPs.....	11
Table D.1 Infiltration Feasibility.....	12
Table D.2 LID Prioritization Summary Matrix.....	16
Table D.3 DCV Calculations for LID BMPs.....	17
Table E.1 Potential Pollutants by Land Use Type.....	19
Table E.2 Water Quality Credits.....	20
Table E.3 Treatment Control BMP Sizing.....	20
Table E.4 Treatment Control BMP Selection.....	21
Table F.1 Hydrologic Conditions of Concern Summary.....	22
Table G.1 Permanent and Operational Source Control Measures.....	24
Table H.1 Construction Plan Cross-reference.....	26

List of Appendices

Appendix 1: Maps and Site Plans.....	31
Appendix 2: Construction Plans.....	32
Appendix 3: Soils Information.....	33
Appendix 4: Historical Site Conditions.....	34
Appendix 5: LID Infeasibility.....	35
Appendix 6: BMP Design Details.....	36
Appendix 7: Hydromodification.....	37
Appendix 8: Source Control.....	38
Appendix 9: O&M.....	39
Appendix 10: Educational Materials.....	- 6 -

Section A: Project and Site Information

PROJECT INFORMATION	
Type of Project:	Warehouse Industrial
Planning Area:	693,182 SF
Community Name:	County of Riverside
Development Name:	TCC - Knox VIII
PROJECT LOCATION	
Latitude & Longitude (DMS): 33°52'5.42"N, 117°15'19.83"W	
Project Watershed and Sub-Watershed: Santa Ana Watershed, San Jacinto Sub-Watershed	
Gross Acres: 15.5	
APN(s): 295-310-016-7, 295-310-037-6, 295-310-038-7, 295-310-039-8 and 295-310-040-8	
Map Book and Page No.: Thomas Brothers Page 747	
PROJECT CHARACTERISTICS	
Proposed or Potential Land Use(s)	Warehouse Industrial
Proposed or Potential SIC Code(s)	4225
Area of Impervious Project Footprint (SF)	400,459
Total Area of <u>proposed</u> Impervious Surfaces within the Project Footprint (SF)/or Replacement	400,459
Does the project consist of offsite road improvements?	<input checked="" type="checkbox"/> Y <input type="checkbox"/> N
Does the project propose to construct unpaved roads?	<input type="checkbox"/> Y <input checked="" type="checkbox"/> N
Is the project part of a larger common plan of development (phased project)?	<input type="checkbox"/> Y <input checked="" type="checkbox"/> N
EXISTING SITE CHARACTERISTICS	
Total area of <u>existing</u> Impervious Surfaces within the Project limits Footprint (SF)	0
Is the project located within any MSHCP Criteria Cell?	<input type="checkbox"/> Y <input checked="" type="checkbox"/> N
If so, identify the Cell number:	N/A
Are there any natural hydrologic features on the project site?	<input type="checkbox"/> Y <input checked="" type="checkbox"/> N
Is a Geotechnical Report attached?	<input checked="" type="checkbox"/> Y <input type="checkbox"/> N
If no Geotech. Report, list the NRCS soils type(s) present on the site (A, B, C and/or D)	N/A
What is the Water Quality Design Storm Depth for the project?	0.60"

The proposed project is located at the southeast corner of Harley Knox Blvd and Decker Road in the County of Riverside, CA. The site is currently vacant and covered with open brush. The proposed project will consist of an industrial warehouse building totaling 239,000+/- SF on approximately 12.2 acres. The site will also allow car parking, drive aisles, truck docks and a truck court. A specific business use is not known at this time, but outdoor storage will not be allowed.

For the onsite water quality treatment, the development will have one (1) drainage area DMA A, and the storm water from the DMA A will be conveyed to the designated bio-retention basin on the east side of the project site through 2 underground storm drain pipes. The basin has been sized to help detain the post construction runoff to levels equivalent to the pre-developed condition.

Moreover, 2 forebays with a 12-inch high curb will be constructed at the bottom entry of the basin to serve as a pre-treatment device to collect debris and sediment. Low flows will discharge through weep holes into the bio-retention basin; higher flows will flow over the 12-inch high curb into the bio-retention basin. Optional pre-treatment devices for added redundancy may include downspout filters at the roof drain and catch basin filters. See Appendix 1 for Post-Construction BMP Site Plan.

The site landscaping areas will not be irrigated with recycled water, and "harvest and use" is not feasible for this development. New trash enclosure will be installed at the site, and the details will be provided in the final Post-Construction BMP Site Map.

Street improvements are part of this project. Water from the streets will be brought on site and treated as required by the city of Perris.

A.1 Maps and Site Plans

When completing your Project-Specific WQMP, include a map of the local vicinity and existing site. In addition, include all grading, drainage, landscape/plant palette and other pertinent construction plans in Appendix 2. At a **minimum**, your WQMP Site Plan should include the following:

- Drainage Management Areas
- Proposed Structural BMPs
- Drainage Path
- Drainage Infrastructure, Inlets, Overflows
- Source Control BMPs
- Buildings, Roof Lines, Downspouts
- Impervious Surfaces
- Standard Labeling
- BMP Locations (Lat/Long)

Use your discretion on whether or not you may need to create multiple sheets or can appropriately accommodate these features on one or two sheets. Keep in mind that the Co-Permittee plan reviewer must be able to easily analyze your project utilizing this template and its associated site plans and maps.

A.2 Identify Receiving Waters

Using Table A.1 below, list in order of upstream to downstream, the receiving waters that the project site is tributary to. Continue to fill each row with the Receiving Water's 303(d) listed impairments (if any), designated beneficial uses, and proximity, if any, to a RARE beneficial use. Include a map of the receiving waters in Appendix 1.

Table A.1 Identification of Receiving Waters

Receiving Waters	EPA Approved 303(d) List Impairments	Designated Beneficial Uses	Proximity to RARE Beneficial Use
Perris Valley MDP Lateral B-8	N/A	-	Not designated as RARE
Perris Valley Channel	N/A	-	Not designated as RARE
San Jacinto River Reach 3, HU#802.11	NONE	AGR, GWR, REC1, REC2, WARM, WILD	Not designated as RARE
Canyon Lake (Railroad Canyon Reservoir), HU#802.11, 802.12	Nutrients, Pathogens	MUN, AGR, GWR, REC1, REC2, WARM, WILD	Not designated as RARE
San Jacinto River Reach 1, HU#802.32,802.31	NONE	MUN, AGR, GWR, REC1, REC2, WARM, WILD	Not designated as RARE
Lake Elsinore	PCBs (Polychlorinated biphenyls), Toxicity	MUN, REC1, REC2, WARM, WILD	Not designated as RARE

A.3 Additional Permits/Approvals required for the Project:

Table A.2 Other Applicable Permits

Agency	Permit Required	
State Department of Fish and Game, 1602 Streambed Alteration Agreement	<input type="checkbox"/> Y	<input checked="" type="checkbox"/> N
State Water Resources Control Board, Clean Water Act (CWA) Section 401 Water Quality Cert.	<input type="checkbox"/> Y	<input checked="" type="checkbox"/> N
US Army Corps of Engineers, CWA Section 404 Permit	<input type="checkbox"/> Y	<input checked="" type="checkbox"/> N
US Fish and Wildlife, Endangered Species Act Section 7 Biological Opinion	<input type="checkbox"/> Y	<input checked="" type="checkbox"/> N
Statewide Construction General Permit Coverage	<input checked="" type="checkbox"/> Y	<input type="checkbox"/> N
Statewide Industrial General Permit Coverage	<input checked="" type="checkbox"/> Y	<input type="checkbox"/> N

Western Riverside MSHCP Consistency Approval (e.g., JPR, DBESP)	<input type="checkbox"/> Y	<input checked="" type="checkbox"/> N
Other (please list in the space below as required) County of Riverside Building and Grading Permits Riverside County FCD – Connection Permit to public storm drain in Harley Knox Blvd	<input checked="" type="checkbox"/> Y	<input type="checkbox"/> N

If yes is answered to any of the questions above, the Co-Permittee may require proof of approval/coverage from those agencies as applicable including documentation of any associated requirements that may affect this Project-Specific WQMP.

Section B: Optimize Site Utilization (LID Principles)

Review of the information collected in Section ‘A’ will aid in identifying the principal constraints on site design and selection of LID BMPs as well as opportunities to reduce imperviousness and incorporate LID Principles into the site and landscape design. For example, **constraints** might include impermeable soils, high groundwater, groundwater pollution or contaminated soils, steep slopes, geotechnical instability, high-intensity land use, heavy pedestrian or vehicular traffic, utility locations or safety concerns. **Opportunities** might include existing natural areas, low areas, oddly configured or otherwise unbuildable parcels, easements and landscape amenities including open space and buffers (which can double as locations for bioretention BMPs), and differences in elevation (which can provide hydraulic head). Prepare a brief narrative for each of the site optimization strategies described below. This narrative will help you as you proceed with your LID design and explain your design decisions to others.

The 2010 Santa Ana MS4 Permit further requires that LID Retention BMPs (Infiltration Only or Harvest and Use) be used unless it can be shown that those BMPs are infeasible. Therefore, it is important that your narrative identify and justify if there are any constraints that would prevent the use of those categories of LID BMPs. Similarly, you should also note opportunities that exist which will be utilized during project design. Upon completion of identifying Constraints and Opportunities, include these on your WQMP Site plan in Appendix 1.

Consideration of “highest and best use” of the discharge should also be considered. For example, Lake Elsinore is evaporating faster than runoff from natural precipitation can recharge it. Requiring infiltration of 85% of runoff events for projects tributary to Lake Elsinore would only exacerbate current water quality problems associated with Pollutant concentration due to lake water evaporation. In cases where rainfall events have low potential to recharge Lake Elsinore (i.e. no hydraulic connection between groundwater to Lake Elsinore, or other factors), requiring infiltration of Urban Runoff from projects is counterproductive to the overall watershed goals. Project proponents, in these cases, would be allowed to discharge Urban Runoff, provided they used equally effective filtration-based BMPs.

Site Constraint:

Base on the site specific infiltration tests and report prepared by Southern California Geotechnical, Inc, dated December 21, 2018 (see Appendix 3). The site soils have very poor infiltration characteristics and the use of infiltration facilities is not recommended.

Solution:

The site drainage design has incorporated bio-retention basins located on the east side of the project site. All site drainage will be conveyed to the bio-retention areas where the runoff will be allowed to pass through a filter media, stone section, and through perforated a pipe network beneath the basin

footprint which will ultimately convey the runoff out to the proposed public storm drain system located in Harley Knox Boulevard.

Site Optimization

The following questions are based upon Section 3.2 of the WQMP Guidance Document. Review of the WQMP Guidance Document will help you determine how best to optimize your site and subsequently identify opportunities and/or constraints, and document compliance.

Did you identify and preserve existing drainage patterns? If so, how? If not, why?

Yes. The site mimics the existing topography by draining from southwest to northeast.

Did you identify and protect existing vegetation? If so, how? If not, why?

No, existing vegetation was not protected within the developed site. Currently the site is vacant and covered with open brush. The developed condition will utilize drought tolerant plants within the landscaped areas to maximize water conservation.

Did you identify and preserve natural infiltration capacity? If so, how? If not, why?

Yes. Natural infiltration capacity was identified by the soil and infiltration report, however it is below the minimum rate and is not expected to be feasible on this project site as a BMP type.

Did you identify and minimize impervious area? If so, how? If not, why?

No. However, the site maintains the minimum amount of landscape required per code.

Did you identify and disperse runoff to adjacent pervious areas? If so, how? If not, why?

No, runoff from impervious areas is not able to drain into pervious areas. Onsite storm drain systems and surface flow will convey the runoff to the basin on the east side of the project site, and the basin will treat the runoff before allowing it to exit the project site.

Section C: Delineate Drainage Management Areas (DMAs)

Utilizing the procedure in Section 3.3 of the WQMP Guidance Document which discusses the methods of delineating and mapping your project site into individual DMAs, complete Table C.1 below to appropriately categorize the types of classification (e.g., Type A, Type B, etc.) per DMA for your project site. Upon completion of this table, this information will then be used to populate and tabulate the corresponding tables for their respective DMA classifications.

Table C.1 DMA Classifications

DMA Name or ID	Surface Type(s) ¹²	Area (Sq. Ft.)	DMA Type
DMA 1	Roofs, Concrete, Ornamental Landscaping, Streets	693,182 Gross area	D

¹Reference Table 2-1 in the WQMP Guidance Document to populate this column

²If multi-surface provide back-up

Table C.2 Type 'A', Self-Treating Areas (Included with mixed DMA1 above)

DMA Name or ID	Area (Sq. Ft.)	Stabilization Type	Irrigation Type (if any)

Table C.3 Type 'B', Self-Retaining Areas (N/A, included with mixed DMA1)

Self-Retaining Area				Type 'C' DMAs that are draining to the Self-Retaining Area		
DMA Name/ ID	Post-project surface type	Area (square feet)	Storm Depth (inches)	DMA Name / ID	[C] from Table C.4	Required Retention Depth (inches)
		[A]	[B]		[C]	

$$[D] = [B] + \frac{[B] \cdot [C]}{[A]}$$

Table C.4 Type 'C', Areas that Drain to Self-Retaining Areas (N/A)

DMA					Receiving Self-Retaining DMA		
DMA Name/ ID	Area (square feet)	Post-project surface type	Impervious fraction	Product	DMA name /ID	Area (square feet)	Ratio
	[A]		[B]			[C] = [A] x [B]	[D]

Table C.5 Type 'D', Areas Draining to BMPs

DMA Name or ID	BMP Name or ID
DMA 1	Bio-retention Basin

Note: More than one drainage management area can drain to a single LID BMP, however, one drainage management area may not drain to more than one BMP.

Section D: Implement LID BMPs

D.1 Infiltration Applicability

Is there an approved downstream ‘Highest and Best Use’ for stormwater runoff (see discussion in Chapter 2.4.4 of the WQMP Guidance Document for further details)? Y N

If yes has been checked, Infiltration BMPs shall not be used for the site; proceed to section D.3

If no, continue working through this section to implement your LID BMPs. It is recommended that you contact your Co-Permittee to verify whether or not your project discharges to an approved downstream ‘Highest and Best Use’ feature.

Geotechnical Report

A Geotechnical Report or Phase I Environmental Site Assessment may be required by the Copermitee to confirm present and past site characteristics that may affect the use of Infiltration BMPs. In addition, the Co-Permittee, at their discretion, may not require a geotechnical report for small projects as described in Chapter 2 of the WQMP Guidance Document. If a geotechnical report has been prepared, include it in Appendix 3. In addition, if a Phase I Environmental Site Assessment has been prepared, include it in Appendix 4.

Is this project classified as a small project consistent with the requirements of Chapter 2 of the WQMP Guidance Document? Y N

Infiltration Feasibility

Table D.1 below is meant to provide a simple means of assessing which DMAs on your site support Infiltration BMPs and is discussed in the WQMP Guidance Document in Chapter 2.4.5. Check the appropriate box for each question and then list affected DMAs as applicable. If additional space is needed, add a row below the corresponding answer.

Table D.1 Infiltration Feasibility

Does the project site...	YES	NO
...have any DMAs with a seasonal high groundwater mark shallower than 10 feet?		X
If Yes, list affected DMAs:		
...have any DMAs located within 100 feet of a water supply well?		X
If Yes, list affected DMAs:		
...have any areas identified by the geotechnical report as posing a public safety risk where infiltration of stormwater could have a negative impact?		X
If Yes, list affected DMAs:		
...have measured in-situ infiltration rates of less than 1.6 inches / hour?	X	
If Yes, list affected DMAs:	A	
...have significant cut and/or fill conditions that would preclude in-situ testing of infiltration rates at the final infiltration surface?		X
If Yes, list affected DMAs:		
...geotechnical report identify other site-specific factors that would preclude effective and safe infiltration?		X
Describe here:		

If you answered “Yes” to any of the questions above for any DMA, Infiltration BMPs should not be used for those DMAs and you should proceed to the assessment for Harvest and Use below.

D.2 Harvest and Use Assessment

Please check what applies:

- Reclaimed water will be used for the non-potable water demands for the project.
- Downstream water rights may be impacted by Harvest and Use as approved by the Regional Board (verify with the Copermittee).
- The Design Capture Volume will be addressed using Infiltration Only BMPs. In such a case, Harvest and Use BMPs are still encouraged, but it would not be required if the Design Capture Volume will be infiltrated or evapotranspired.

If any of the above boxes have been checked, Harvest and Use BMPs need not be assessed for the site. If none of the above criteria applies, follow the steps below to assess the feasibility of irrigation use, toilet use and other non-potable uses (e.g., industrial use).

Irrigation Use Feasibility

Complete the following steps to determine the feasibility of harvesting stormwater runoff for Irrigation Use BMPs on your site:

Step 1: Identify the total area of irrigated landscape on the site, and the type of landscaping used.

Total Area of Irrigated Landscape: 111,383

Type of Landscaping (Conservation Design or Active Turf): Conservation Design

Step 2: Identify the planned total of all impervious areas on the proposed project from which runoff might be feasibly captured and stored for irrigation use. Depending on the configuration of buildings and other impervious areas on the site, you may consider the site as a whole, or parts of the site, to evaluate reasonable scenarios for capturing and storing runoff and directing the stored runoff to the potential use(s) identified in Step 1 above.

Total Area of Impervious Surfaces: 419,851

Step 3: Cross reference the Design Storm depth for the project site (see Exhibit A of the WQMP Guidance Document) with the left column of Table 2-3 in Chapter 2 to determine the minimum area of Effective Irrigated Area per Tributary Impervious Area (EIATIA).

Enter your EIATIA factor: .84 ac/ac

Step 4: Multiply the unit value obtained from Step 3 by the total of impervious areas from Step 2 to develop the minimum irrigated area that would be required.

Minimum required irrigated area : 352,675

Step 5: Determine if harvesting stormwater runoff for irrigation use is feasible for the project by comparing the total area of irrigated landscape (Step 1) to the minimum required irrigated area (Step 4).

Minimum required irrigated area (Step 4)	Available Irrigated Landscape (Step 1)
352,675	111,383

Toilet Use Feasibility

Complete the following steps to determine the feasibility of harvesting stormwater runoff for toilet flushing uses on your site:

Step 1: Identify the projected total number of daily toilet users during the wet season, and account for any periodic shut downs or other lapses in occupancy:

Projected Number of Daily Toilet Users: 250

Project Type: industrial

Step 2: Identify the planned total of all impervious areas on the proposed project from which runoff might be feasibly captured and stored for toilet use. Depending on the configuration of buildings and other impervious areas on the site, you may consider the site as a whole, or parts of the site, to evaluate reasonable scenarios for capturing and storing runoff and directing the stored runoff to the potential use(s) identified in Step 1 above.

Total Area of Impervious Surfaces: 419,851

Step 3: Enter the Design Storm depth for the project site (see Exhibit A) into the left column of Table 2-2 in Chapter 2 to determine the minimum number of toilet users per tributary impervious acre (TUTIA).

Enter your TUTIA factor: 175 tu/ac

Step 4: Multiply the unit value obtained from Step 3 by the total of impervious areas from Step 2 to develop the minimum number of toilet users that would be required.

Minimum number of toilet users: 43,750

Step 5: Determine if harvesting stormwater runoff for toilet flushing use is feasible for the project by comparing the Number of Daily Toilet Users (Step 1) to the minimum required number of toilet users (Step 4).

Minimum required Toilet Users (Step 4)	Projected number of toilet users (Step 1)
43,750	250

Other Non-Potable Use Feasibility

Are there other non-potable uses for stormwater runoff on the site (e.g. industrial use)? See Chapter 2 of the Guidance for further information. If yes, describe below. If no, write N/A.

N/A

Step 1: Identify the projected average daily non-potable demand, in gallons per day, during the wet season and accounting for any periodic shut downs or other lapses in occupancy or operation.

Average Daily Demand: N/A

Step 2: Identify the planned total of all impervious areas on the proposed project from which runoff might be feasibly captured and stored for the identified non-potable use. Depending on the configuration of buildings and other impervious areas on the site, you may consider the site as a whole, or parts of the site, to evaluate reasonable scenarios for capturing and storing runoff and directing the stored runoff to the potential use(s) identified in Step 1 above.

Total Area of Impervious Surfaces: N/A

Step 3: Enter the Design Storm depth for the project site (see Exhibit A) into the left column of Table 2-4 in Chapter 2 to determine the minimum demand for non-potable uses per tributary impervious acre.

Enter the factor from Table 2-4: N/A

Step 4: Multiply the unit value obtained from Step 3 by the total of impervious areas from Step 2 to develop the minimum number of gallons per day of non-potable use that would be required.

Minimum required use: N/A

Step 5: Determine if harvesting stormwater runoff for other non-potable use is feasible for the project by comparing the projected average daily use (Step 1) to the minimum required non-potable use (Step 4).

Minimum required non-potable use (Step 4)	Projected average daily use (Step 1)
N/A	N/A

If Irrigation, Toilet and Other Use feasibility anticipated demands are less than the applicable minimum values, Harvest and Use BMPs are not required and you should proceed to utilize LID Bioretention and Biotreatment per Section 3.4.2 of the WQMP Guidance Document.

D.3 Bioretention and Biotreatment Assessment

Other LID Bioretention and Biotreatment BMPs as described in Chapter 2.4.7 of the WQMP Guidance Document are feasible on nearly all development sites with sufficient advance planning.

Select one of the following:

LID Bioretention/Biotreatment BMPs will be used for some or all DMAs of the project as noted below in Section D.4 (note the requirements of Section 3.4.2 in the WQMP Guidance Document).

A site-specific analysis demonstrating the technical infeasibility of all LID BMPs has been performed and is included in Appendix 5. If you plan to submit an analysis demonstrating the technical infeasibility of LID BMPs, request a pre-submittal meeting with the Copermittee to discuss this option. Proceed to Section E to document your alternative compliance measures.

D.4 Feasibility Assessment Summaries

From the Infiltration, Harvest and Use, Bioretention and Biotreatment Sections above, complete Table D.2 below to summarize which LID BMPs are technically feasible, and which are not, based upon the established hierarchy.

Table D.2 LID Prioritization Summary Matrix

DMA Name/ID	LID BMP Hierarchy				No LID (Alternative Compliance)
	1. Infiltration	2. Harvest and use	3. Bioretention	4. Biotreatment	
DMA A	<input type="checkbox"/>	<input type="checkbox"/>	<input checked="" type="checkbox"/>	<input type="checkbox"/>	<input type="checkbox"/>
	<input type="checkbox"/>	<input type="checkbox"/>	<input type="checkbox"/>	<input type="checkbox"/>	<input type="checkbox"/>
	<input type="checkbox"/>	<input type="checkbox"/>	<input type="checkbox"/>	<input type="checkbox"/>	<input type="checkbox"/>
	<input type="checkbox"/>	<input type="checkbox"/>	<input type="checkbox"/>	<input type="checkbox"/>	<input type="checkbox"/>
	<input type="checkbox"/>	<input type="checkbox"/>	<input type="checkbox"/>	<input type="checkbox"/>	<input type="checkbox"/>
	<input type="checkbox"/>	<input type="checkbox"/>	<input type="checkbox"/>	<input type="checkbox"/>	<input type="checkbox"/>

For those DMAs where LID BMPs are not feasible, provide a brief narrative below summarizing why they are not feasible, include your technical infeasibility criteria in Appendix 5, and proceed to Section E below to document Alternative Compliance measures for those DMAs. Recall that each proposed DMA must pass through the LID BMP hierarchy before alternative compliance measures may be considered.

Base on the information provided in Section D, bio-retention LID BMP will be utilized for the entire site. See Appendix 1 Post-Construction BMP Site Plan for bio-retention basin detail.

D.5 LID BMP Sizing

Each LID BMP must be designed to ensure that the Design Capture Volume will be addressed by the selected BMPs. First, calculate the Design Capture Volume for each LID BMP using the V_{BMP} worksheet in Appendix F of the LID BMP Design Handbook. Second, design the LID BMP to meet the required V_{BMP} using a method approved by the Copermittee. Utilize the worksheets found in the LID BMP Design Handbook or consult with your Copermittee to assist you in correctly sizing your LID BMPs. Complete Table D.3 below to document the Design Capture Volume and the Proposed Volume for each LID BMP. Provide the completed design procedure sheets for each LID BMP in Appendix 6. You may add additional rows to the table below as needed.

Table D.3 DCV Calculations for LID BMPs

DMA Type/ID	DMA Area (square feet)	Post-Project Surface Type	Effective Impervious Fraction, I_f	DMA Runoff Factor	DMA Areas x Runoff Factor	<i>Bio-Retention Basin</i>		
						Design Storm Depth (in)	Design Capture Volume, V_{BMP} (cubic feet)	Proposed Volume on Plans (cubic feet)
	[A]		[B]	[C]	[A] x [C]			
DMA A	116,954	landscape	0.1	0.11	12,917.5			
DMA A	239,717	Roof	1.0	0.89	213,827.6			
DMA A	162,978	pvt	1.0	0.89	145,376.4			
DMA A	137,500	Offsite street	1.0	0.89	122,650			
DMA A	36,033	Offsite landscape	0.1	0.11	3,980.1			
	$A_T = \Sigma[A]$ 693,182				$\Sigma = [D]$ 498,752.6	[E] 0.60	$[F] = \frac{[D] \times [E]}{12}$ 24,937.6	[G] 26,281

[B], [C] is obtained as described in Section 2.3.1 of the WQMP Guidance Document

[E] is obtained from Exhibit A in the WQMP Guidance Document

[G] is obtained from a design procedure sheet, such as in LID BMP Design Handbook and placed in Appendix 6

Section E: Alternative Compliance (LID Waiver Program)

LID BMPs are expected to be feasible on virtually all projects. Where LID BMPs have been demonstrated to be infeasible as documented in Section D, other Treatment Control BMPs must be used (subject to LID waiver approval by the Copermittee). Check one of the following Boxes:

LID Principles and LID BMPs have been incorporated into the site design to fully address all Drainage Management Areas. No alternative compliance measures are required for this project and thus this Section is not required to be completed.

- Or -

The following Drainage Management Areas are unable to be addressed using LID BMPs. A site-specific analysis demonstrating technical infeasibility of LID BMPs has been approved by the Co-Permittee and included in Appendix 5. Additionally, no downstream regional and/or sub-regional LID BMPs exist or are available for use by the project. The following alternative compliance measures on the following pages are being implemented to ensure that any pollutant loads expected to be discharged by not incorporating LID BMPs, are fully mitigated.

E.1 Identify Pollutants of Concern

Utilizing Table A.1 from Section A above which noted your project's receiving waters and their associated EPA approved 303(d) listed impairments, cross reference this information with that of your selected Priority Development Project Category in Table E.1 below. If the identified General Pollutant Categories are the same as those listed for your receiving waters, then these will be your Pollutants of Concern and the appropriate box or boxes will be checked on the last row. The purpose of this is to document compliance and to help you appropriately plan for mitigating your Pollutants of Concern in lieu of implementing LID BMPs.

Table E.1 Potential Pollutants by Land Use Type

Priority Development Project Categories and/or Project Features (check those that apply)	General Pollutant Categories							
	Bacterial Indicators	Metals	Nutrients	Pesticides	Toxic Organic Compounds	Sediments	Trash & Debris	Oil & Grease
<input type="checkbox"/> Detached Residential Development	P	N	P	P	N	P	P	P
<input type="checkbox"/> Attached Residential Development	P	N	P	P	N	P	P	P ⁽²⁾
<input checked="" type="checkbox"/> Commercial/Industrial Development	P ⁽³⁾	P	P ⁽¹⁾	P ⁽¹⁾	P ⁽⁵⁾	P ⁽¹⁾	P	P
<input type="checkbox"/> Automotive Repair Shops	N	P	N	N	P ^(4, 5)	N	P	P
<input type="checkbox"/> Restaurants (>5,000 ft ²)	P	N	N	N	N	N	P	P
<input type="checkbox"/> Hillside Development (>5,000 ft ²)	P	N	P	P	N	P	P	P
<input type="checkbox"/> Parking Lots (>5,000 ft ²)	P ⁽⁶⁾	P	P ⁽¹⁾	P ⁽¹⁾	P ⁽⁴⁾	P ⁽¹⁾	P	P
<input type="checkbox"/> Retail Gasoline Outlets	N	P	N	N	P	N	P	P
Project Priority Pollutant(s) of Concern	<input checked="" type="checkbox"/>	<input checked="" type="checkbox"/>	<input checked="" type="checkbox"/>	<input checked="" type="checkbox"/>	<input checked="" type="checkbox"/>	<input checked="" type="checkbox"/>	<input checked="" type="checkbox"/>	<input checked="" type="checkbox"/>

P = Potential

N = Not Potential

⁽¹⁾ A potential Pollutant if non-native landscaping exists or is proposed onsite; otherwise not expected

⁽²⁾ A potential Pollutant if the project includes uncovered parking areas; otherwise not expected

⁽³⁾ A potential Pollutant is land use involving animal waste

⁽⁴⁾ Specifically petroleum hydrocarbons

⁽⁵⁾ Specifically solvents

⁽⁶⁾ Bacterial indicators are routinely detected in pavement runoff

E.2 Stormwater Credits (N/A)

Projects that cannot implement LID BMPs but nevertheless implement smart growth principles are potentially eligible for Stormwater Credits. Utilize Table 3-8 within the WQMP Guidance Document to identify your Project Category and its associated Water Quality Credit. If not applicable, write N/A.

Table E.2 Water Quality Credits

Qualifying Project Categories	Credit Percentage ²
<i>Total Credit Percentage¹</i>	

¹Cannot Exceed 50%

²Obtain corresponding data from Table 3-8 in the WQMP Guidance Document

E.3 Sizing Criteria (N/A)

After you appropriately considered Stormwater Credits for your project, utilize Table E.3 below to appropriately size them to the DCV, or Design Flow Rate, as applicable. Please reference Chapter 3.5.2 of the WQMP Guidance Document for further information.

Table E.3 Treatment Control BMP Sizing

DMA Type/ID	DMA Area (square feet)	Post-Project Surface Type	Effective Impervious Fraction, I _f	DMA Runoff Factor	DMA Area x Runoff Factor	Enter BMP Name / Identifier Here			
	[A]		[B]	[C]	[A] x [C]				
						<i>Design Storm Depth (in)</i> <i>Minimum Design Capture Volume or Design Flow Rate (cubic feet or cfs)</i> <i>Total Storm Water Credit % Reduction</i> <i>Proposed Volume or Flow on Plans (cubic feet or cfs)</i>			
	$A_T = \sum[A]$				$\sum = [D]$	[E]	$[F] = \frac{[D] \times [E]}{[G]}$	$[F] \times (1-[H])$	[I]

[B], [C] is obtained as described in Section 2.3.1 from the WQMP Guidance Document

[E] is for Flow-Based Treatment Control BMPs [E] = .2, for Volume-Based Control Treatment BMPs, [E] obtained from Exhibit A in the WQMP Guidance Document

[G] is for Flow-Based Treatment Control BMPs [G] = 43,560, for Volume-Based Control Treatment BMPs, [G] = 12

[H] is from the Total Credit Percentage as Calculated from Table E.2 above

[I] as obtained from a design procedure sheet from the BMP manufacturer and should be included in Appendix 6

E.4 Treatment Control BMP Selection

Treatment Control BMPs typically provide proprietary treatment mechanisms to treat potential pollutants in runoff, but do not sustain significant biological processes. Treatment Control BMPs must have a removal efficiency of a medium or high effectiveness as quantified below:

- **High:** equal to or greater than 80% removal efficiency
- **Medium:** between 40% and 80% removal efficiency

Such removal efficiency documentation (e.g., studies, reports, etc.) as further discussed in Chapter 3.5.2 of the WQMP Guidance Document, must be included in Appendix 6. In addition, ensure that proposed Treatment Control BMPs are properly identified on the WQMP Site Plan in Appendix 1.

Table E.4 Treatment Control BMP Selection

Selected Treatment Control BMP Name or ID ¹	Priority Pollutant(s) of Concern to Mitigate ²	Removal Percentage ³	Efficiency
N/A. APPLIES TO PROPRIETARY TREATMENT.			

¹ Treatment Control BMPs must not be constructed within Receiving Waters. In addition, a proposed Treatment Control BMP may be listed more than once if they possess more than one qualifying pollutant removal efficiency.

² Cross Reference Table E.1 above to populate this column.

³ As documented in a Co-Permittee Approved Study and provided in Appendix 6.

Section F: Hydromodification

F.1 Hydrologic Conditions of Concern (HCOC) Analysis

Once you have determined that the LID design is adequate to address water quality requirements, you will need to assess if the proposed LID Design may still create a HCOC. Review Chapters 2 and 3 (including Figure 3-7) of the WQMP Guidance Document to determine if your project must mitigate for Hydromodification impacts. If your project meets one of the following criteria which will be indicated by the check boxes below, you do not need to address Hydromodification at this time. However, if the project does not qualify for Exemptions 1, 2 or 3, then additional measures must be added to the design to comply with HCOC criteria. This is discussed in further detail below in Section F.2.

HCOC EXEMPTION 1: The Priority Development Project disturbs less than one acre. The Copermitttee has the discretion to require a Project-Specific WQMP to address HCOCs on projects less than one acre on a case by case basis. The disturbed area calculation should include all disturbances associated with larger common plans of development.

Does the project qualify for this HCOC Exemption? Y N

If Yes, HCOC criteria do not apply.

HCOC EXEMPTION 2: The volume and time of concentration¹ of storm water runoff for the post-development condition is not significantly different from the pre-development condition for a 2-year return frequency storm (a difference of 5% or less is considered insignificant) using one of the following methods to calculate:

- Riverside County Hydrology Manual
- Technical Release 55 (TR-55): Urban Hydrology for Small Watersheds (NRCS 1986), or derivatives thereof, such as the Santa Barbara Urban Hydrograph Method
- Other methods acceptable to the Co-Permittee

Does the project qualify for this HCOC Exemption? Y N

If Yes, report results in Table F.1 below and provide your substantiated hydrologic analysis in Appendix 7.

Table F.1 Hydrologic Conditions of Concern Summary

	2 year – 24 hour		
	Pre-condition	Post-condition	% Difference
Time of Concentration	N/A	N/A	N/A
Volume (Cubic Feet)	N/A	N/A	N/A

¹ Time of concentration is defined as the time after the beginning of the rainfall when all portions of the drainage basin are contributing to flow at the outlet.

HCOC EXEMPTION 3: All downstream conveyance channels to an adequate sump (for example, Prado Dam, Lake Elsinore, Canyon Lake, Santa Ana River, or other lake, reservoir or naturally erosion resistant feature) that will receive runoff from the project are engineered and regularly maintained to ensure design flow capacity; no sensitive stream habitat areas will be adversely affected; or are not identified on the Co-Permittees Hydromodification Susceptibility Maps.

Does the project qualify for this HCOC Exemption? Y N

If Yes, HCOC criteria do not apply and note below which adequate sump applies to this HCOC qualifier:

This project qualifies for exemption due to connection to the Riverside County Master Plan Drainage facility Lateral B-8 which ultimately drains to Canyon Lake.

F.2 HCOC Mitigation

If none of the above HCOC Exemption Criteria are applicable, HCOC criteria is considered mitigated if they meet one of the following conditions:

- a. Additional LID BMPS are implemented onsite or offsite to mitigate potential erosion or habitat impacts as a result of HCOCs. This can be conducted by an evaluation of site-specific conditions utilizing accepted professional methodologies published by entities such as the California Stormwater Quality Association (CASQA), the Southern California Coastal Water Research Project (SCCRWP), or other Co-Permittee approved methodologies for site-specific HCOC analysis.
- b. The project is developed consistent with an approved Watershed Action Plan that addresses HCOC in Receiving Waters.
- c. Mimicking the pre-development hydrograph with the post-development hydrograph, for a 2-year return frequency storm. Generally, the hydrologic conditions of concern are not significant, if the post-development hydrograph is no more than 10% greater than pre-development hydrograph. In cases where excess volume cannot be infiltrated or captured and reused, discharge from the site must be limited to a flow rate no greater than 110% of the pre-development 2-year peak flow.

Section G: Source Control BMPs

Source control BMPs include permanent, structural features that may be required in your project plans — such as roofs over and berms around trash and recycling areas — and Operational BMPs, such as regular sweeping and “housekeeping”, that must be implemented by the site’s occupant or user. The MEP standard typically requires both types of BMPs. In general, Operational BMPs cannot be substituted for a feasible and effective permanent BMP. Using the Pollutant Sources/Source Control Checklist in Appendix 8, review the following procedure to specify Source Control BMPs for your site:

1. **Identify Pollutant Sources:** Review Column 1 in the Pollutant Sources/Source Control Checklist. Check off the potential sources of Pollutants that apply to your site.
2. **Note Locations on Project-Specific WQMP Exhibit:** Note the corresponding requirements listed in Column 2 of the Pollutant Sources/Source Control Checklist. Show the location of each Pollutant source and each permanent Source Control BMP in your Project-Specific WQMP Exhibit located in Appendix 1.
3. **Prepare a Table and Narrative:** Check off the corresponding requirements listed in Column 3 in the Pollutant Sources/Source Control Checklist. In the left column of Table G.1 below, list each potential source of runoff Pollutants on your site (from those that you checked in the Pollutant Sources/Source Control Checklist). In the middle column, list the corresponding permanent, Structural Source Control BMPs (from Columns 2 and 3 of the Pollutant Sources/Source Control Checklist) used to prevent Pollutants from entering runoff. **Add additional narrative** in this column that explains any special features, materials or methods of construction that will be used to implement these permanent, Structural Source Control BMPs.
4. **Identify Operational Source Control BMPs:** To complete your table, refer once again to the Pollutant Sources/Source Control Checklist. List in the right column of your table the Operational BMPs that should be implemented as long as the anticipated activities continue at the site. Copermittee stormwater ordinances require that applicable Source Control BMPs be implemented; the same BMPs may also be required as a condition of a use permit or other revocable Discretionary Approval for use of the site.

Table G.1 Permanent and Operational Source Control Measures

Potential Sources of Runoff pollutants	Permanent Structural /Non-Structural Source Control BMPs	Operational Source Control BMPs
On-Site Storm Drain Inlet	Mark all inlets with the words “Only Rain Down the Storm Drain” or similar. Catch Basin Markers may be available from the Riverside County Flood Control and Water Conservation District, call 951.955.1200 to verify.	<ul style="list-style-type: none"> • Maintain and periodically repaint or replace inlet markings. • Provide stormwater pollution prevention information to new site owners, lessees, or operators. • See applicable operational BMPs in Fact Sheet SC-44, “Drainage System Maintenance,” in the CASQA Stormwater Quality Handbooks at www.cabmphandbooks.com • Include the following in lease agreements: “Tenant shall not allow anyone to discharge anything to storm drains or to store or deposit materials so as to create a potential discharge to storm drains.”

Loading Docks	The project site will have truck docks which shown on the Post-Construction BMP Site Plan. The truck docks shall be inspected on a weekly basis to help ensure that any trash and debris are collected prior to being washed into the underground storm drain system. All storm water runoff from the loading dock areas will be discharged into infiltration basins and/or underground infiltration chambers prior to conveyance to the public storm drain system. Documentation of such inspection/maintenance shall be kept by the owner in perpetuity.	<ul style="list-style-type: none"> Move loaded and unloaded items indoors as soon as possible. See Fact Sheet SC-30, "Outdoor Loading and Unloading," in the CASQA Stormwater Quality Handbooks at www.cabmphandbooks.com
Fire Sprinkler Test Water	Underground fire protection service and fire sprinklers test will be provided per the uniform fire code and the requirements of the County of Riverside	<ul style="list-style-type: none"> Provide a means to drain fire sprinkler test water to the sanitary sewer.
Plazas, sidewalks, and parking lots.	Documentation of such sweeping shall be kept by the owner in perpetuity. Frequency of sweeping shall be adjusted as needed to maintain a clean site.	<ul style="list-style-type: none"> Sweep plazas, sidewalks, and parking lots regularly to prevent accumulation of litter and debris. Collect debris from pressure washing to prevent entry into the storm drain system. Collect wash water containing any cleaning agent or degreaser and discharge to the sanitary sewer not to a storm drain.
Refuse Trash Storage Areas	Trash container storage areas shall be paved with an impervious surface designed not to allow run-on from adjoining areas. They shall be designed to divert drainage from adjoining roofs and pavements from the surrounding area, and screened or walled to prevent off-site transport of trash. Trash dumpsters (containers) shall be leak proof and have attached covers and lids. Trash enclosures shall be roofed per City standards and the details on the WQMP exhibit in Appendix 1. Trash compactors shall be roofed and set on a concrete pad per City standards. The pad shall be a minimum of one foot larger all around than the trash compactor and sloped to drain to a sanitary sewer line. Connection of trash area drains to the MS4 is prohibited. See CASQA SD-32 BMP fact sheet in Appendix 10 for additional information. Signs shall be posted on or near dumpsters with the words "Do not dump hazardous materials here" or similar.	Adequate number of receptacles shall be provided. Inspect receptacles regularly; repair or replace leaky receptacles. Keep receptacles covered. Prohibit/prevent dumping of liquid or hazardous wastes. Post "no hazardous materials" signs. Inspect and pick up litter daily and clean up spills immediately. Keep spill control materials available onsite. See fact sheet SC-34 "Waste Handling and Disposal" in the CASQA Stormwater Quality Handbook at www.cabmphandbooks.com and in Appendix 10.

Section H: Construction Plan Checklist

“This section will be completed and addressed at the time of the final WQMP submittal”

Populate Table H.1 below to assist the plan checker in an expeditious review of your project. The first two columns will contain information that was prepared in previous steps, while the last column will be populated with the corresponding plan sheets. This table is to be completed with the submittal of your final Project-Specific WQMP.

Table H.1 Construction Plan Cross-reference

BMP No. or ID	BMP Identifier and Description	Corresponding Plan Sheet(s)	BMP Location (Lat/Long)

Note that the updated table — or Construction Plan WQMP Checklist — is **only a reference tool** to facilitate an easy comparison of the construction plans to your Project-Specific WQMP. Co-Permittee staff can advise you regarding the process required to propose changes to the approved Project-Specific WQMP.

Section I: Operation, Maintenance and Funding

“This section will be completed and addressed at the time of the final WQMP submittal”

The Copermittee will periodically verify that Stormwater BMPs on your site are maintained and continue to operate as designed. To make this possible, your Copermittee will require that you include in Appendix 9 of this Project-Specific WQMP:

1. A means to finance and implement facility maintenance in perpetuity, including replacement cost.
2. Acceptance of responsibility for maintenance from the time the BMPs are constructed until responsibility for operation and maintenance is legally transferred. A warranty covering a period following construction may also be required.
3. An outline of general maintenance requirements for the Stormwater BMPs you have selected.
4. Figures delineating and designating pervious and impervious areas, location, and type of Stormwater BMP, and tables of pervious and impervious areas served by each facility. Geo-locating the BMPs using a coordinate system of latitude and longitude is recommended to help facilitate a future statewide database system.
5. A separate list and location of self-retaining areas or areas addressed by LID Principles that do not require specialized O&M or inspections but will require typical landscape maintenance as noted in Chapter 5, pages 85-86, in the WQMP Guidance. Include a brief description of typical landscape maintenance for these areas.

Your local Co-Permittee will also require that you prepare and submit a detailed Stormwater BMP Operation and Maintenance Plan that sets forth a maintenance schedule for each of the Stormwater BMPs built on your site. An agreement assigning responsibility for maintenance and providing for inspections and certification may also be required.

Details of these requirements and instructions for preparing a Stormwater BMP Operation and Maintenance Plan are in Chapter 5 of the WQMP Guidance Document.

Maintenance Mechanism:

BMP	Responsible Party(s)	Inspection/Maintenance Activities Required	Minimum Frequency of Activities
Landscape and Irrigation	Owner	<p>See CASQA BMP Fact Sheet SD-10 in Appendix 10</p> <ul style="list-style-type: none"> -Site landscaping design shall be implemented in accordance with the requirements of the site specific WQMP and local agency requirements. -Site landscaping maintenance shall begin immediately after it has been planted. -Maintenance of landscaping shall occur on a weekly basis and adjusted accordingly based on current conditions and seasonal needs. -Inspection of irrigation system shall be provided on a bi-weekly basis to ensure proper function of the irrigation system, no significant overspray is occurring. -Malfunctioning systems shall be repaired or replaced immediately. -Inspect plant health on a monthly basis. Repair or replace unhealthy plants as needed. -Inspect side slopes of basins and sloped areas on a bi-weekly basis and repair as needed. Re-plant and apply erosion protection to those areas to help prevent erosion in the future. -Landscape clippings shall be swept and picked up immediately to prevent it from entering the storm drain system or adjacent sedimentation basins and filtration basins. Dispose of landscape clippings in a legal manner 	Weekly
MS4 Stenciling and Signage	Owner	<p>See CASQA BMP Fact Sheet SD-13 in Appendix 10</p> <ul style="list-style-type: none"> -MS4 Stenciling and signage shall be placed during construction and inspection and maintenance shall begin upon completion of construction. -Inspect catch basin stenciling on a bi-monthly basis. Replace any damaged, missing or faded stencils in a timely manner. 	Bi-monthly
Common area litter control, loading docks and trash storage areas	Owner	<p>See CASQA BMP Fact Sheet SD-32 in Appendix 10</p> <ul style="list-style-type: none"> -Inspection and Maintenance of common areas, loading docks and trash storage areas shall begin upon completion of construction. -Visual inspection of trash storage areas shall take place on a weekly basis and adjusted on an as needed basis. -Inspect areas for trash and debris. Remove any found trash and debris immediately. Dispose of trash and debris in a legal manner. -Inspect areas for any spills. Pick up/clean up found spills immediately. Dispose of spill material in a legal manner. 	Daily

<p>Parking lot sweeping</p>		<p>See CASQA BMP Fact Sheet SE-7 in Appendix 10 -Parking lot sweeping shall begin after the completion of construction and take place on a monthly basis. Dispose of picked up material in a legal manner.</p>	<p>Monthly</p>
<p>Drainage facility (including roof drains) inspection and maintenance</p>		<p>-Inspection and maintenance of site drainage facilities and roof drains shall begin immediately upon completion of construction. -Catch basins and roof drain inlet shall be clear of any debris - prior to any storm event to ensure proper function of the roof drains. Collected debris shall be disposed of in a legal manner. Catch basin filters shall be inspected on a monthly basis. Catch basin filters that have exceeded 50% of the storage capacity shall be cleaned immediately. -Catch basin filters shall be maintained per the manufacturer's specifications. -Damaged catch basin filters shall be replaced with an approved equal prior to the next storm event or as soon as practicable.</p>	<p>Monthly & after rain event</p>
<p>Bioretention Basin (Sand Filters)</p>		<p>See Appendix 10 -Once the sedimentation and sand filter basin have gone on-line, inspections should occur after every major storm for the first year to ensure that proper stabilization and function is achieved. Continuous inspection and maintenance shall be provided once every six months. Special attention should be paid to how long water remains standing in the basin after a storm; standing water within the basin more than 48 hours after a storm indicates that the filtration rates are insufficient and maintenance of the filter basin bottom is needed. If standing water remains after 48 hours, the standing water shall be removed in accordance with the local agency guidelines and maintenance of the filter basin bottom shall be scheduled immediately. Factors that are typically responsible for clogging the filter basin bottom include upstream sediment erosion and excessive compaction of the basin bottom. These should be repaired immediately to help achieve the desired filtration rates. -Observe and document evidence of collected sediments, trash, debris and oils/greases. -Sediments, trash, debris and oils/greases shall be removed and disposed of in a legal manner. -Observe and document evidence of erosion of side slopes or flowlines. -Schedule repair of eroded side slopes or flowlines immediately. -Protection measures against further erosion shall be placed until the eroded areas are repaired. Protection measures should be at a minimum placement of gravel bags and fiber rolls to prevent further erosion of the affected areas until the areas have been repaired and vegetation has been established.</p>	<p>Every 6 months</p>

Will the proposed BMPs be maintained by a Home Owners' Association (HOA) or Property Owners Association (POA)?

Y N

Owner Information:

Dave Drake
Executive Vice President
Trammell Crow Company
3501 Jamboree road, Suite 230
Newport Beach, CA 92660
949-400-6065
Email: DDrake@trammellcrow.com

Include your Operation and Maintenance Plan and Maintenance Mechanism in Appendix 9. Additionally, include all pertinent forms of educational materials for those personnel that will be maintaining the proposed BMPs within this Project-Specific WQMP in Appendix 10.

Appendix 1: Maps and Site Plans

Location Map, WQMP Site Plan and Receiving Waters Map

LEGEND

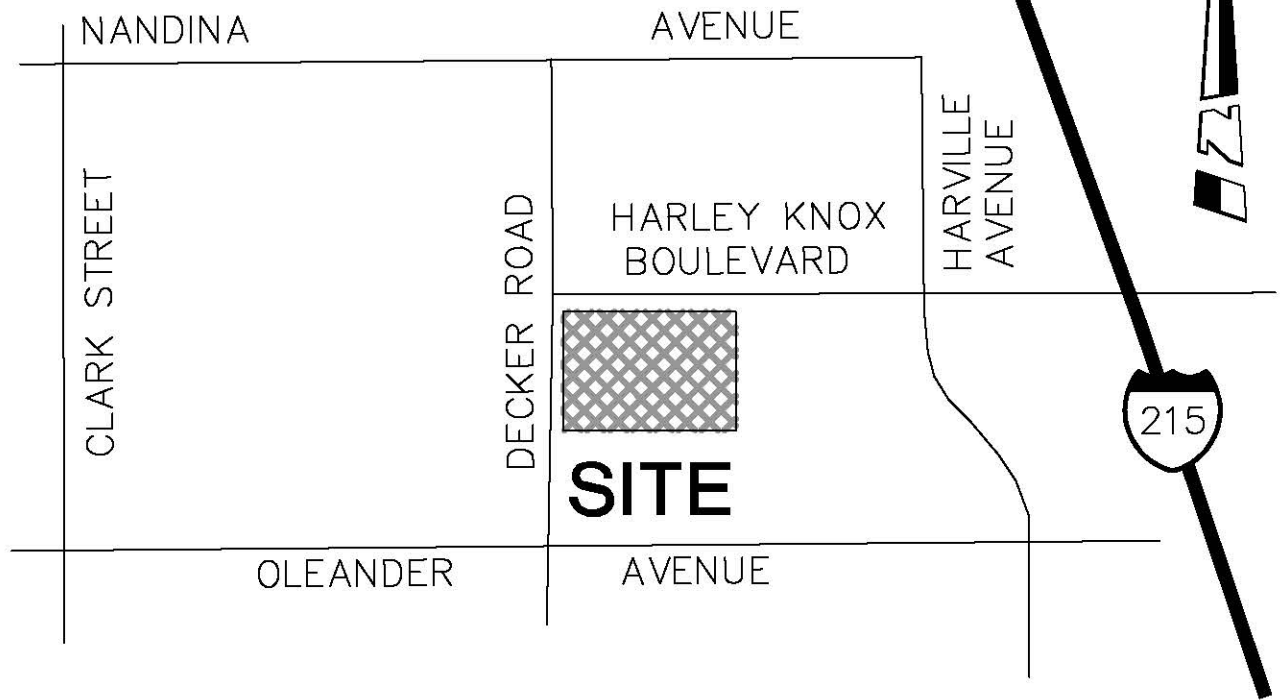

VICINITY MAP

NOT TO SCALE

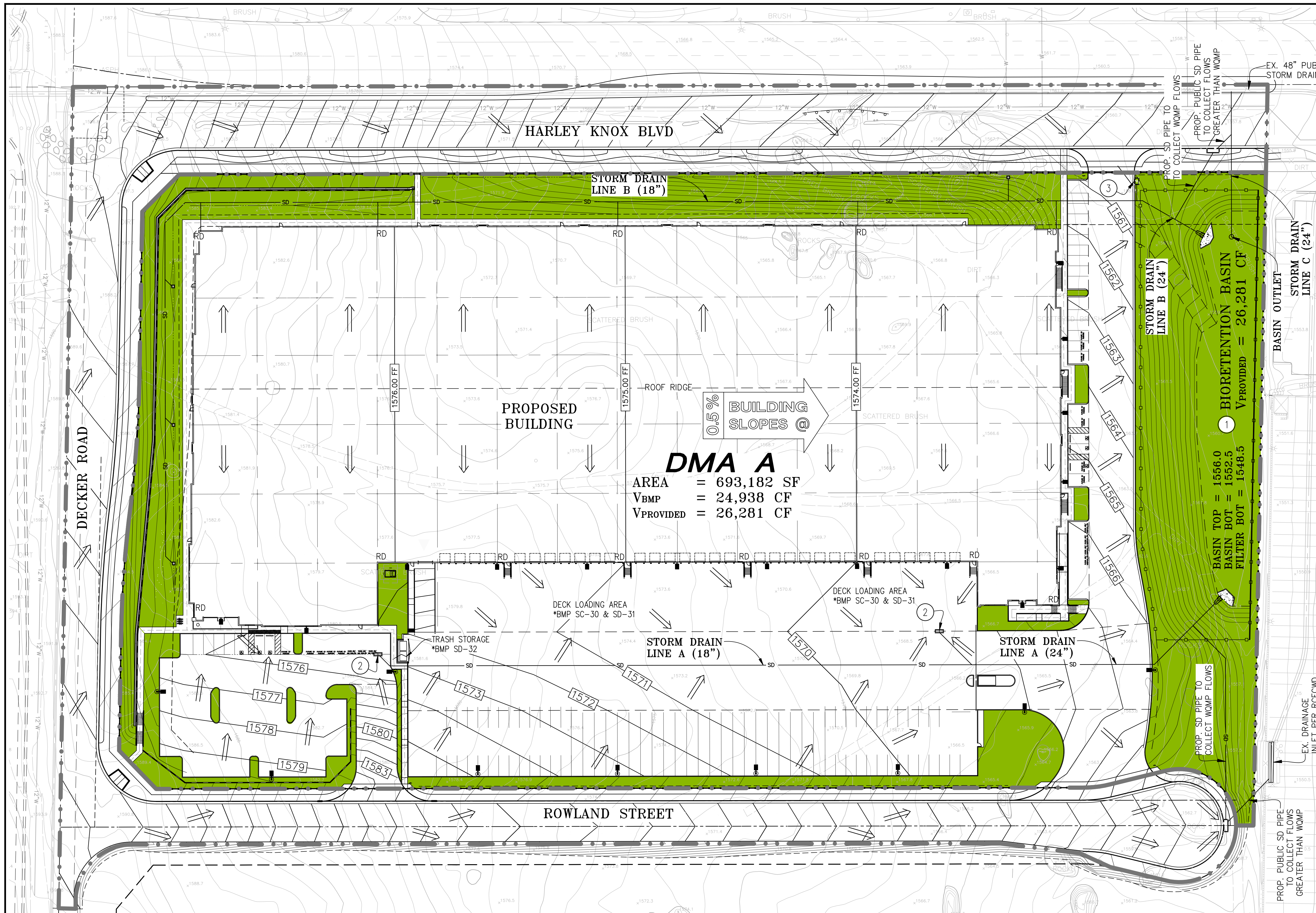

WQMP BMP NOTES

- 1 BIORETENTION BASIN, SEE DETAIL HEREON
- 2 INSTALL BIO-CLEAN GRATE INLET FILTER SEE DETAIL HEREON
- 3 INSTALL BIO-CLEAN CURB INLET FILTER SEE DETAIL HEREON

LEGEND

- SD PROPOSED STORM DRAIN
- WQMP BOUNDARY / LIMIT FOR *BMP SC-41 BUILDING & GROUND MAINTENANCE
- PROPOSED CURB OPENING INLET W/ FILTER INSERT
- PROPOSED BROOKS CATCH BASIN
- PROPOSED GRATED INLET W/ FILTER INSERT
- PROPOSED LANDSCAPING AREA - *BMP SD-10 & SD-12
- CB CATCH BASIN
- TG TOP OF GRATE
- FLOW DIRECTION
- CLEANOUT

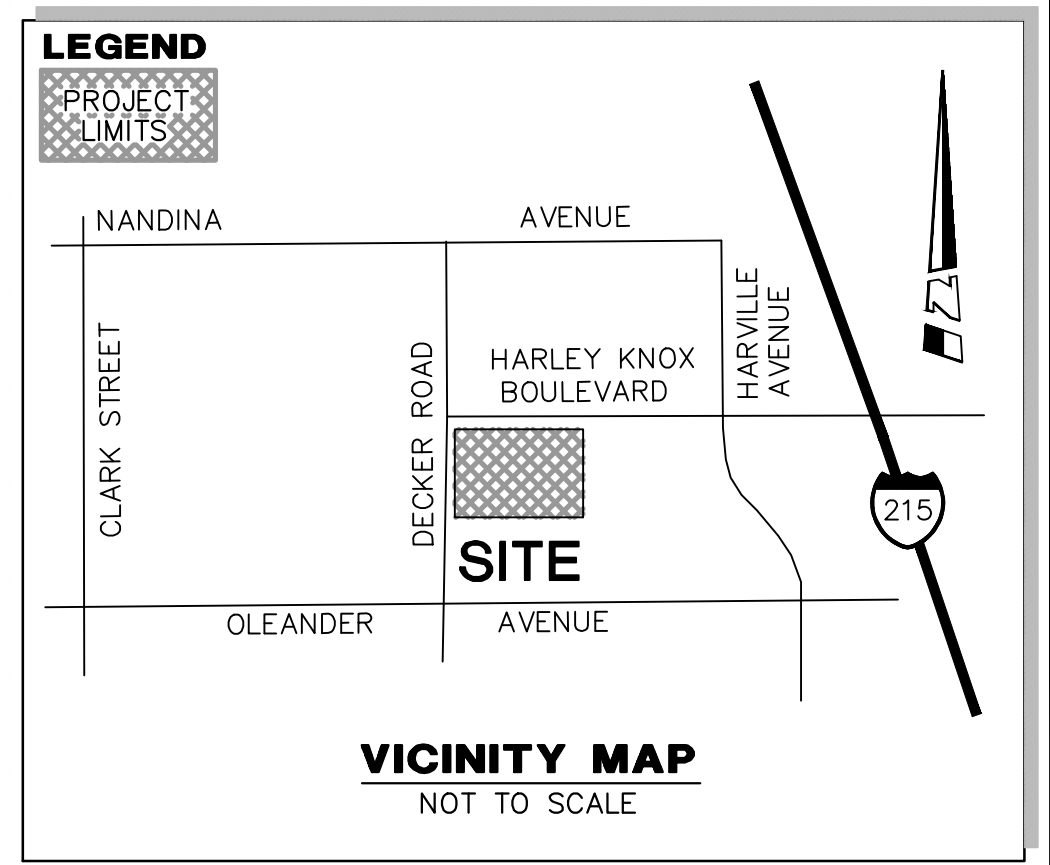

DMA A
 AREA = 693,182 SF
 VBMP = 24,938 CF
 VPROVIDED = 26,281 CF

BIORETENTION BASIN
 BASIN TOP = 1556.0
 BASIN BOT = 1548.5
 FILTER BOT = 1548.5
 VPROVIDED = 26,281 CF

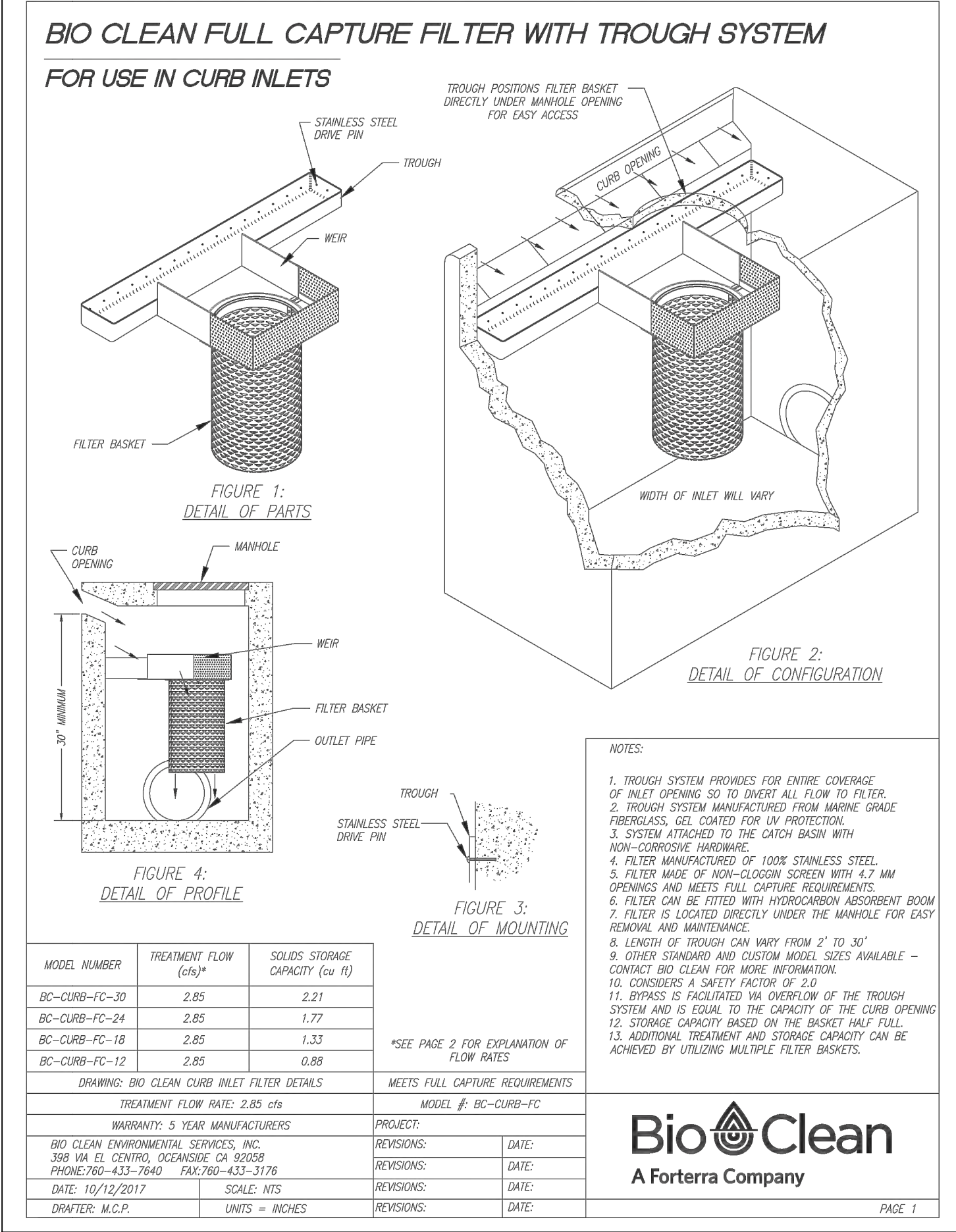

2 CURB INLET BASKET SYSTEM
NOT TO SCALE

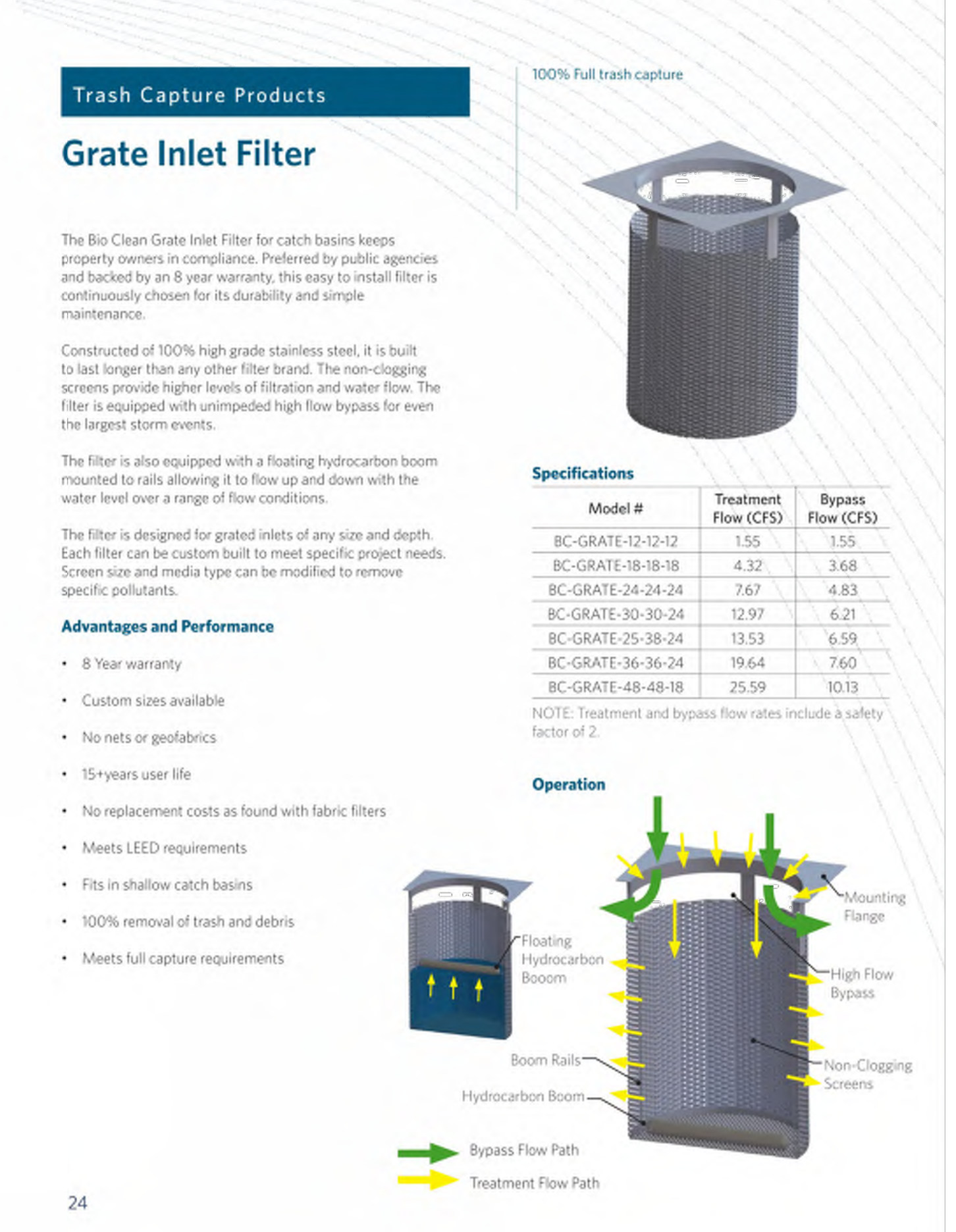

3 GRATE INLET SKIMMER BOX
NOT TO SCALE

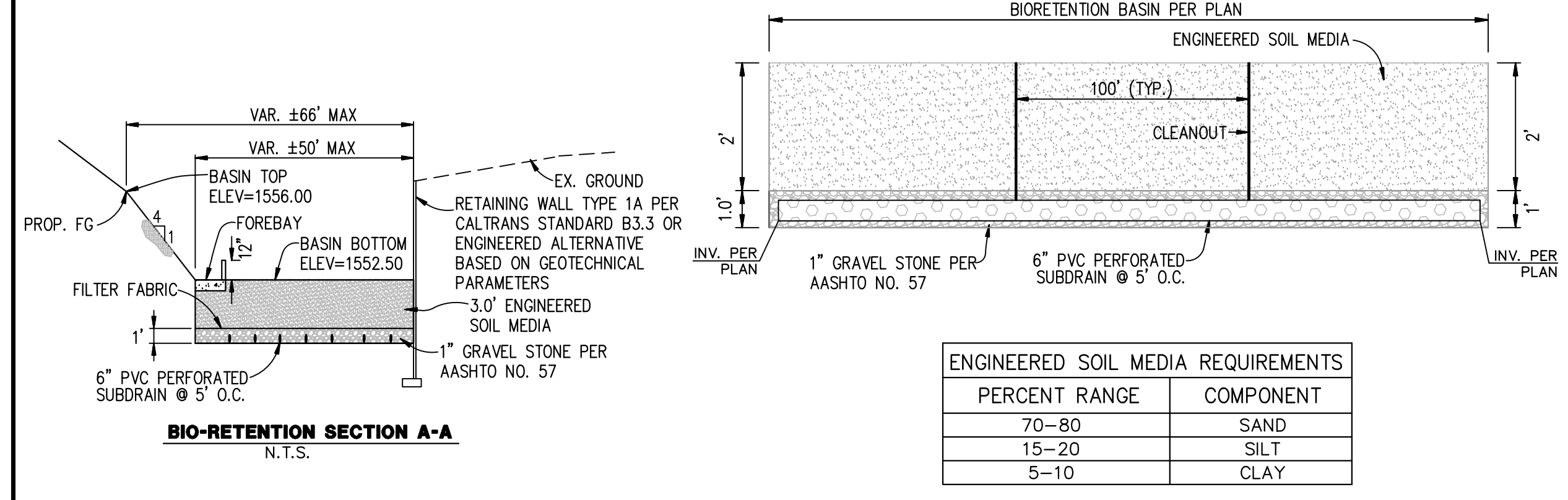

1 BIORETENTION BASIN A
N.T.S.

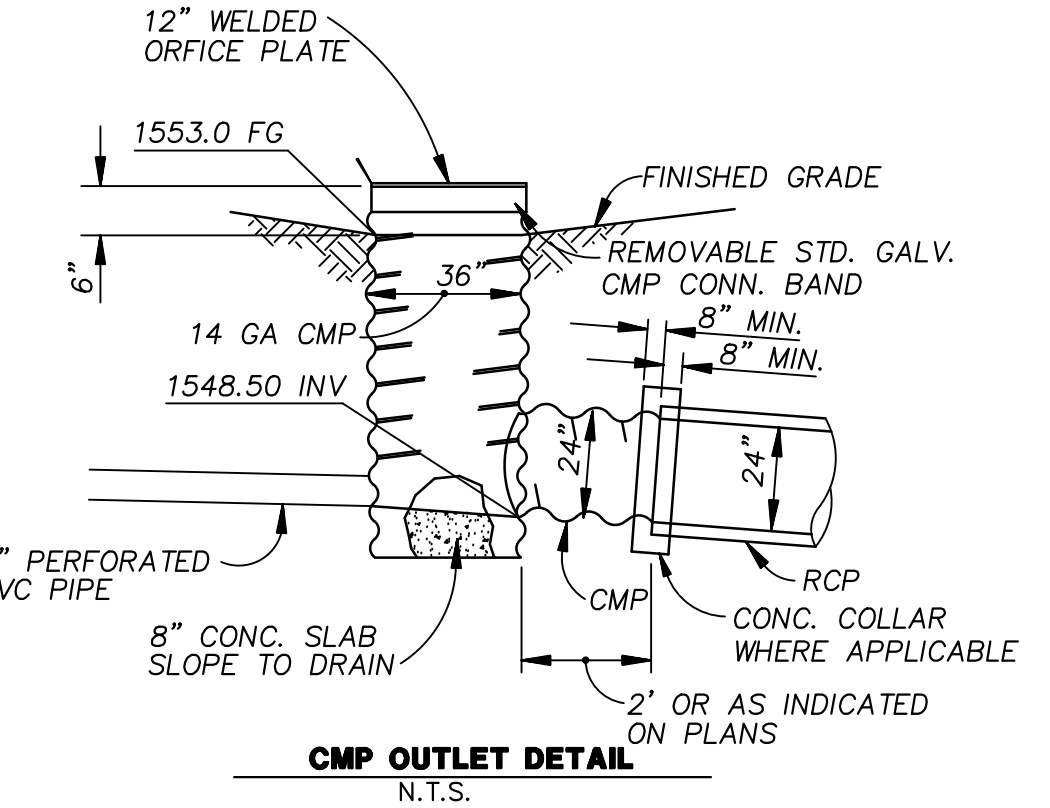

CMP OUTLET DETAIL
N.T.S.

NAME	d _p (FT)	d _s (FT)	W _f (FT)	d _e (FT)	A _{PROVIDE} (SF)	V _{PROVIDE} (CF)
BIORETENTION BASIN	0.50	3.0	61	1.50	14,244	26,281

OWNER/DEVELOPER
 TRAMMELL CROW COMPANY
 3501 JAMBORREE ROAD, SUITE 230
 NEWPORT BEACH, CA 92660
 PHONE (949) 400-6065
 CONTACT PERSON: DAVE DRAKE

CIVIL ENGINEER
 HUITT-ZOLLARS, INC.
 3990 CONCOURS, SUITE 330
 ONTARIO, CALIFORNIA 91764
 PHONE: (909) 941-7799, X11411
 CONTACT PERSON: JOHNNY MURAD

CONSTRUCT 6" PCC CONCRETE OVER 12" NATIVE (95% MINIMUM COMPACTION)



PROJECT BMP CONFORMANCE ANALYSIS

NAME	AREA (SF)	IMPERVIOUS AREA (SF)	PERVIOUS AREA (SF)	i	C	V _{IMP} (CF)	BMP	A _{PROVIDE} (SF)	V _{PROVIDE} (CF)
DMA A	693,182	540,195	152,987	0.78	0.60	24,938	BIORETENTION BASIN	14,244	26,281



STENCIL LOGO
N.T.S.

HUITT-ZOLLARS
 Huitt-Zollars, Inc. Ontario
 3990 CONCOURS, SUITE 330 • ONTARIO, CALIFORNIA 91764 • (909) 941-7799

CITY OF PERRIS
POST-CONSTRUCTION BMP SITE MAP
 TCC - KNOX VIII
 SE CORNER OF HARLEY KNOX BLVD AND DECKER RD
 COUNTY OF RIVERSIDE

Receiving Waters Map

TCC - KNOX VIII

Legend

 TCC - KNOX VIII



Appendix 2: Construction Plans

Grading and Drainage Plans

Attached Conceptual Grading and Drainage Plans

This section will be completed and addressed at the time of the final WQMP submittal

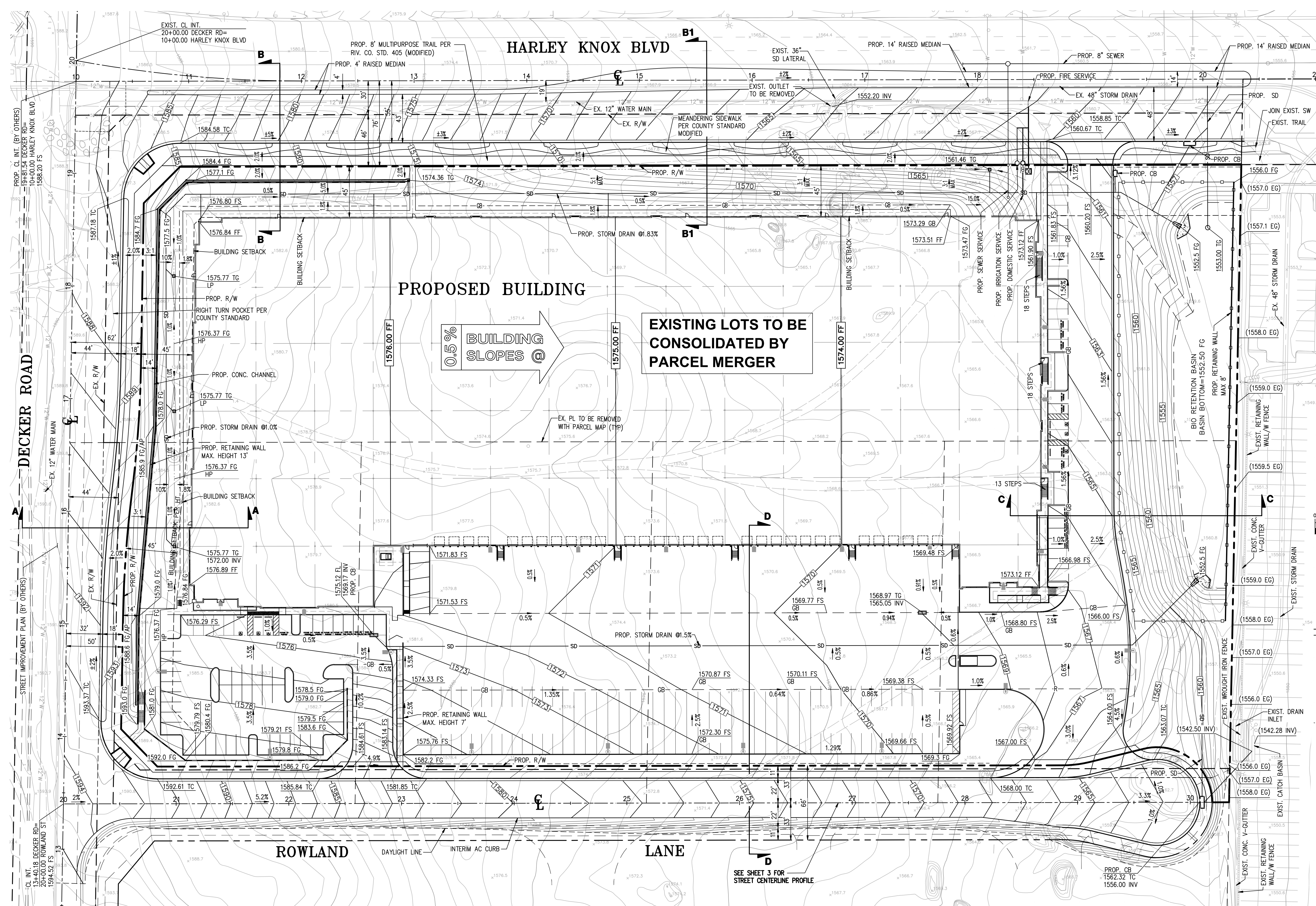

DEVELOPER/APPLICANT
TRAMMELL CROW SO. CAL.
DEVELOPMENT INC.
 DAVE DRAKE
 3501 JAMBORRE ROAD, SUITE 230
 PINEWORTH BEACH, CA 92660
 (949)400-6065

CIVIL ENGINEER
HUITT-ZOLLARS, INC.
 JOHNNY MURAD
 3990 CONCOURS, SUITE 330
 ONTARIO, CA 91764
 (909)941-7799

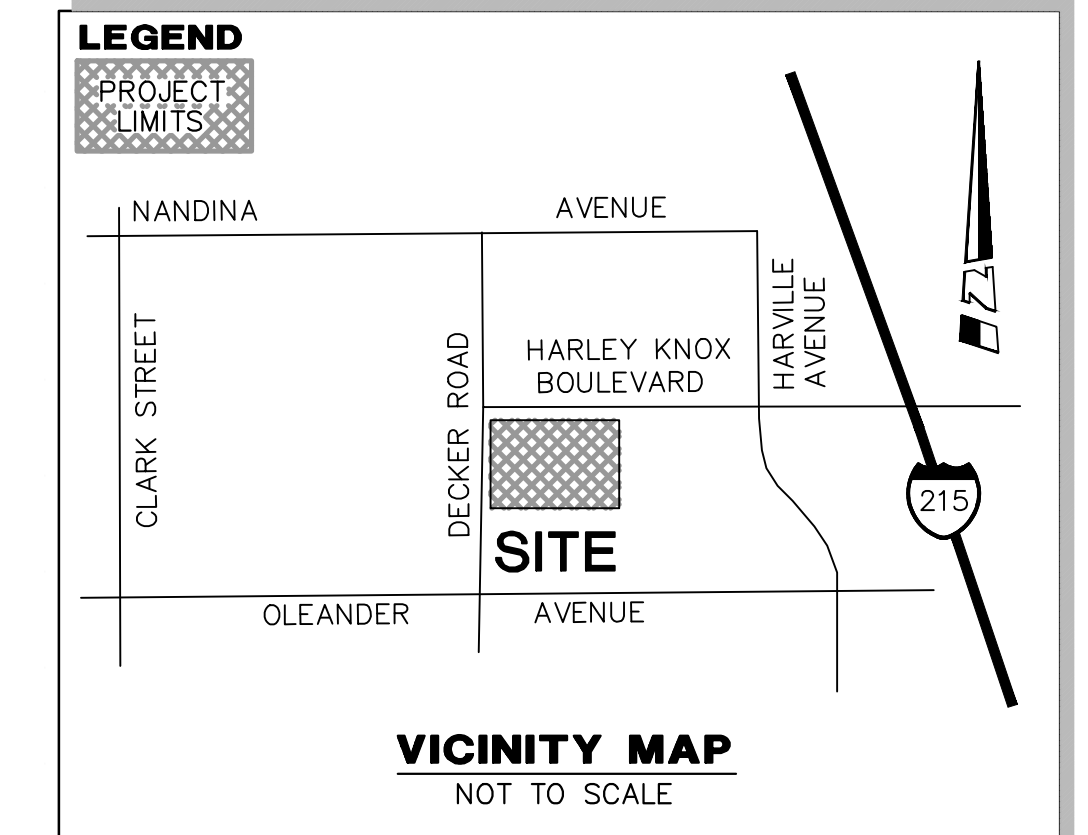

PROPOSED BUILDING

EXISTING LOTS TO BE CONSOLIDATED BY PARCEL MERGER

0.5% BUILDING SLOPES @

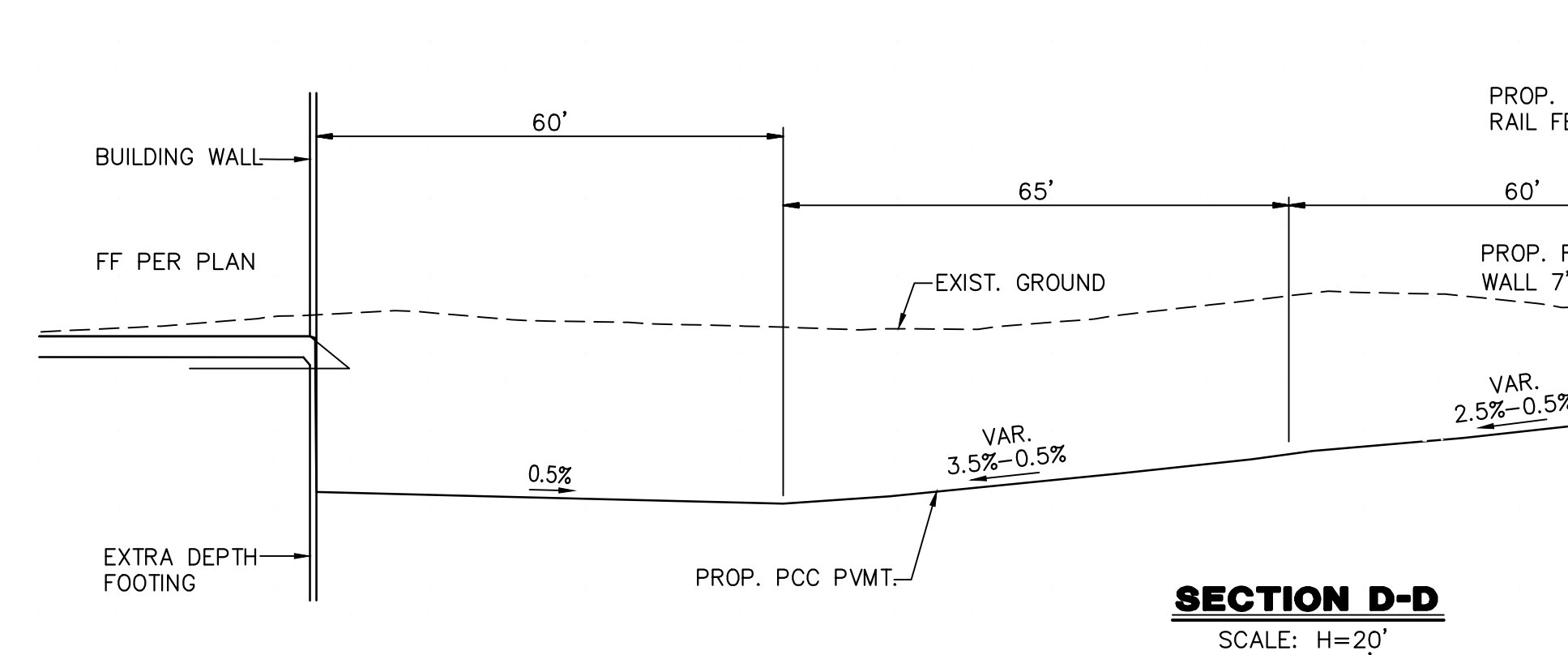
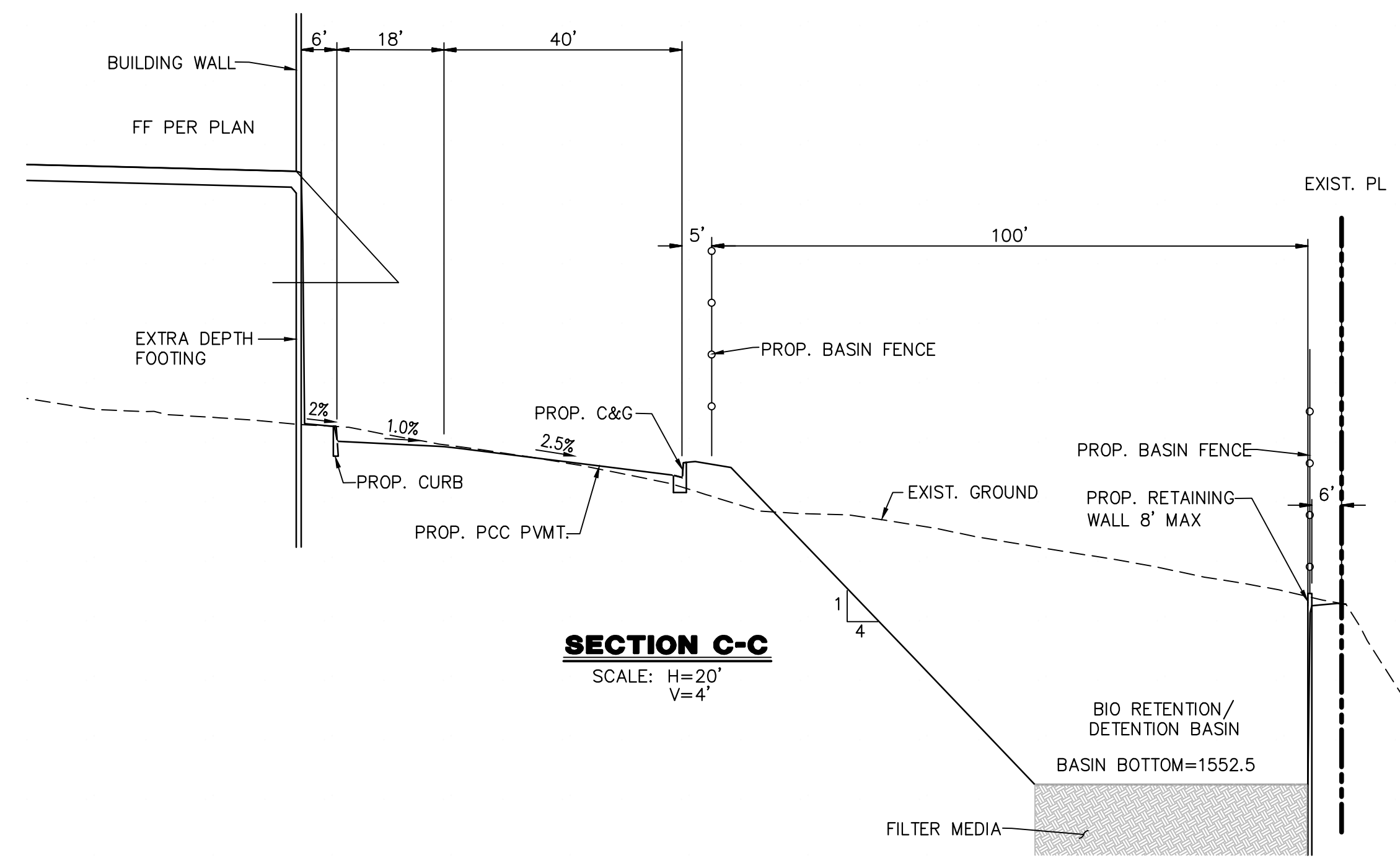
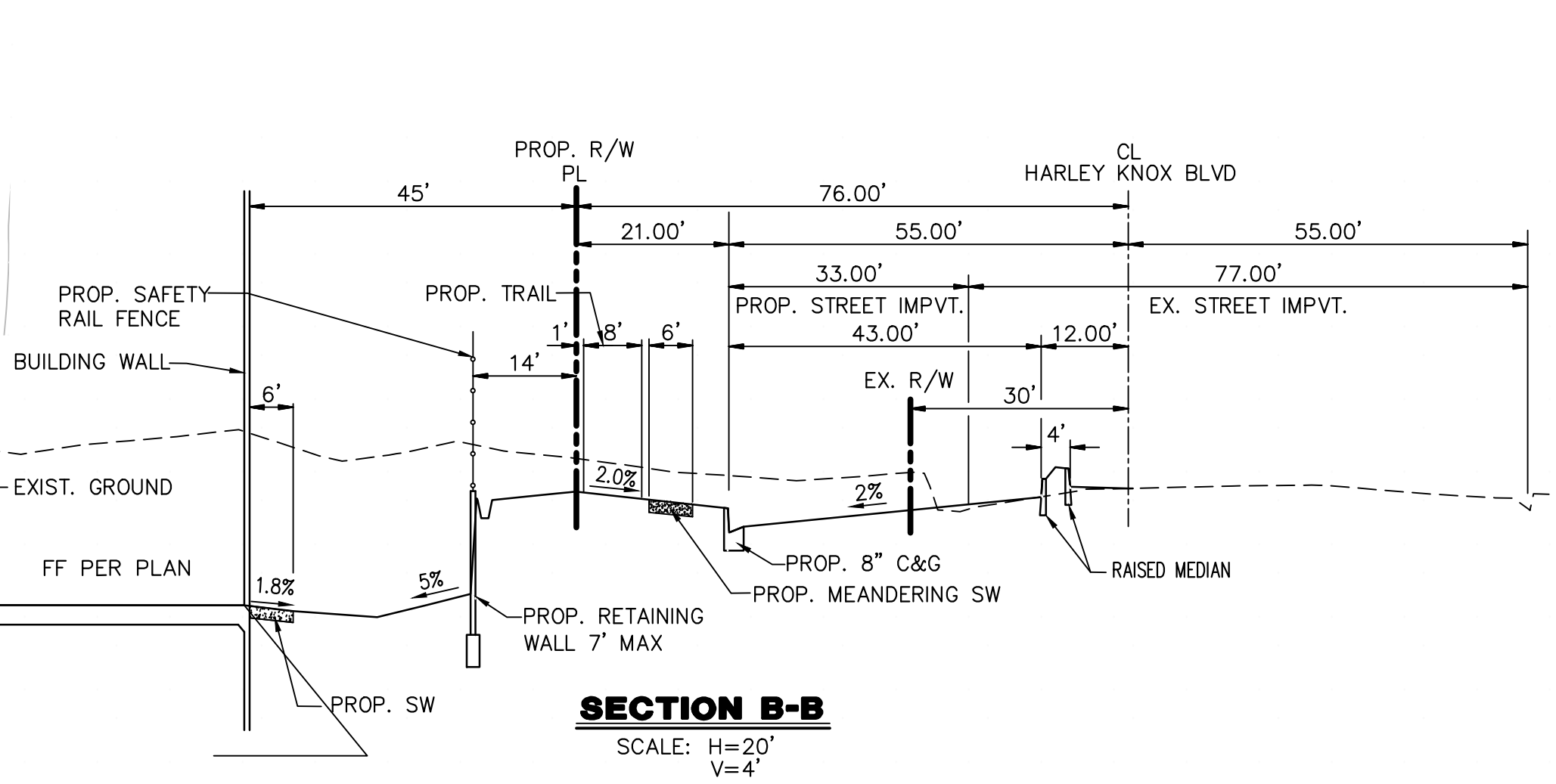
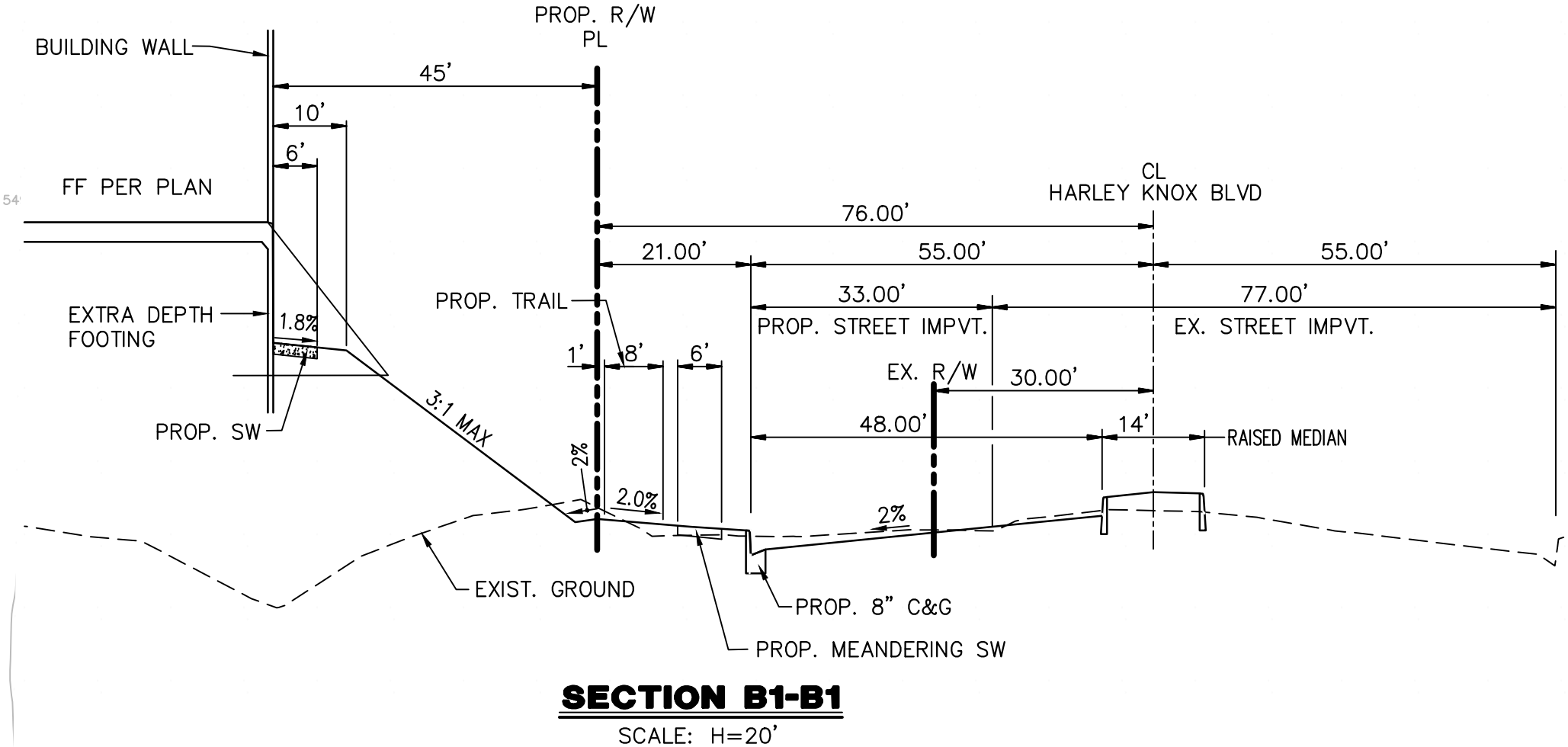
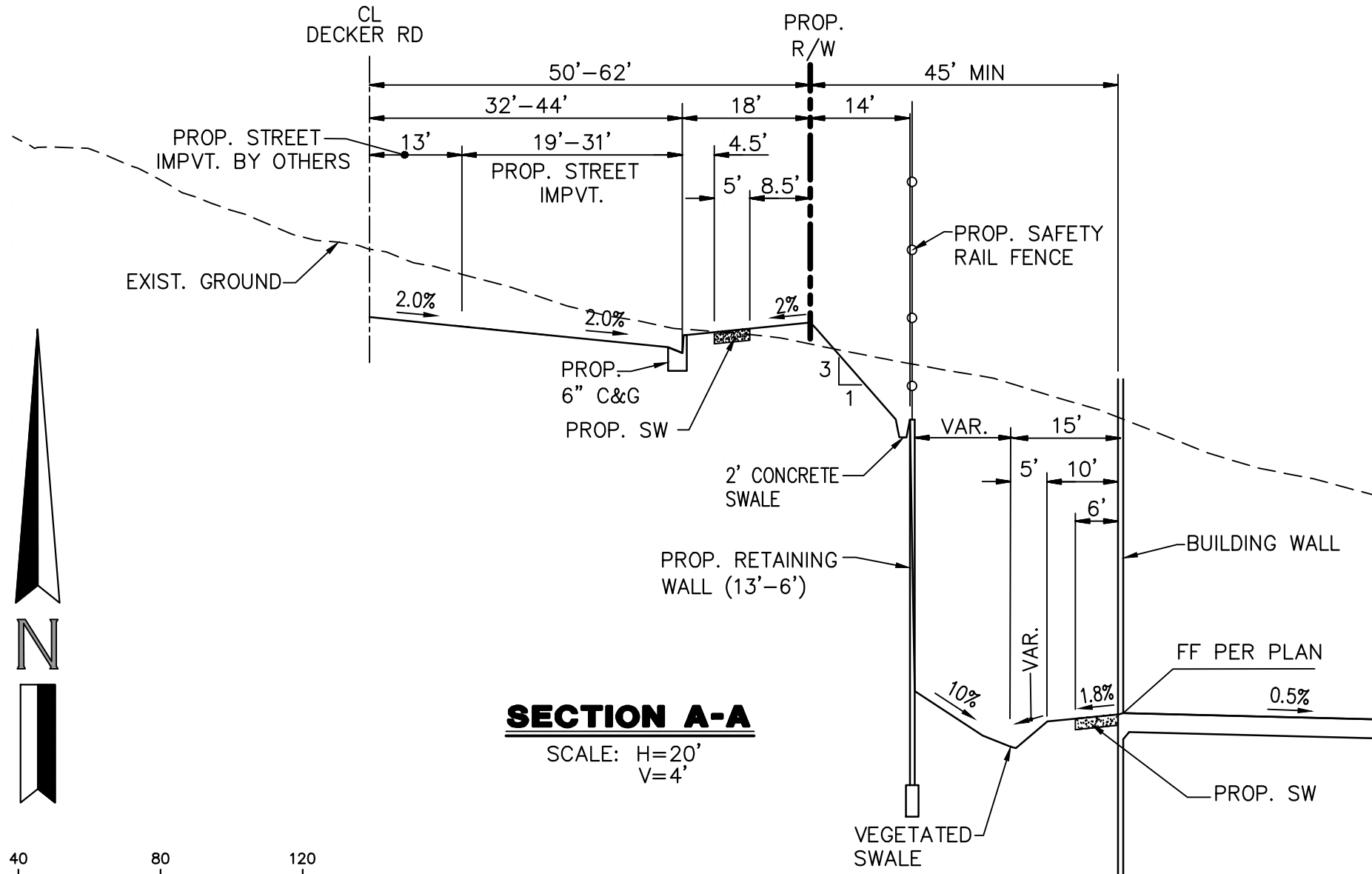
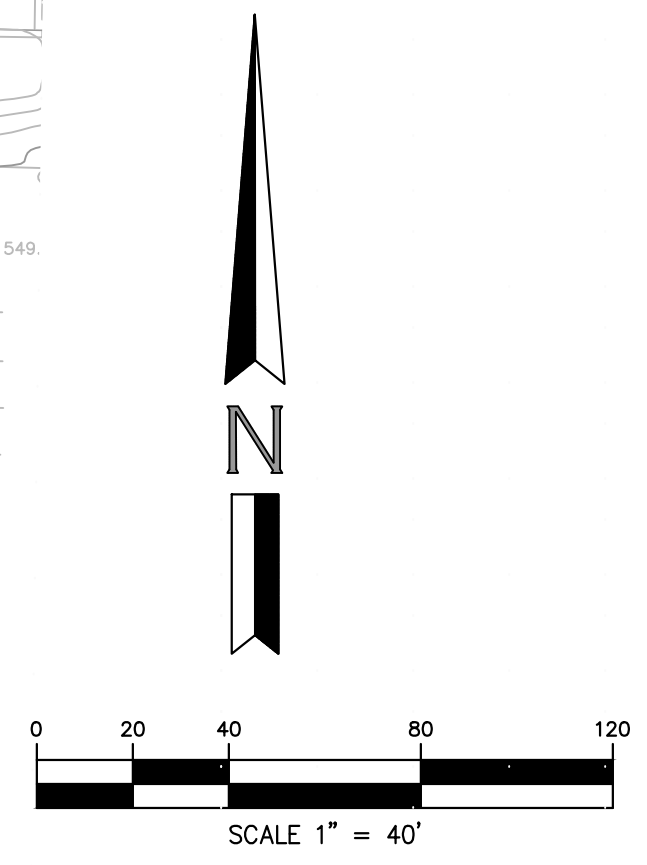

PRELIMINARY EARTHWORK VOLUMES

	CUT (CY)	FILL (CY)
RAW VOLUMES:	46,770	43,814
(-) Shrinkage(10%):	4,677	-
(+) Subsideance (0):	-	0
Subtotal:	42,093	43,814
Overexcavation Row:	36,945	36,945
(-) Shrinkage:	3,695	-
Subtotal:	33,251	36,945
Additional Volumes:	1,000	-
Total:	76,344	80,759

4,415 CY SHORT

EARTHWORK NOTE:
 EARTHWORK ESTIMATE IS BASED ON SOILS PARAMETERS PROVIDED BY THE SOILS ENGINEER. ADJUSTMENTS MAY BE REQUIRED BASED ON FINAL DESIGN OF SLAB AND SITE PAVING THICKNESS. ADDITIONAL ADJUSTMENTS MAY BE REQUIRED BASED ON SITE SOIL CHARACTERISTICS EXPERIENCED DURING CONSTRUCTION. QUANTITIES ARE FOR FEE PURPOSES ONLY - NOT FOR BIDDING. CONTRACTOR SHALL PERFORM INDEPENDENT EARTHWORK CALCULATIONS AND BID A COMPLETE JOB.

BENCH MARK: Z 1143 1961 (PID #DX2103) + 31/4" BRASS DISK, SET IN TOP OF A CONCRETE MONUMENT.

STATION IS NEAR THE INTERSECTION OF INTERSTATE 215 AND VAN BUREN BLVD. ABOUT 0.1 MILE N OF AVE. A, ABOUT 0.35 S DIRT PATROL ON THE E. SIDE OF 41ST RAILROAD TRACKS, 15 FEET SE OF MILEPOST 11, 183 FEET SE OF A SWITCH STAND, 25 FEET E OF TRACKS, 5.4 FEET W OF 215 FWY RIGHT OF WAY, AND 5 INCHES ABOUT GROUND. MARK IS METROPOLITAN WATER DISTRICT OF SOUTHERN CALIFORNIA STANDARD DISK STAMPED Z 1143 1961.

ELEVATION = 1535.16' (NAVD 88)

BASIS OF BEARINGS:
 THE BASIS OF BEARINGS FOR THIS SURVEY IS THE CALIFORNIA COORDINATE SYSTEM, ZONE 6, NAD 83 (EPOCH 2017.50) AS DETERMINED LOCALLY BY A LINE BETWEEN CONTINUOUS GLOBAL POSITIONING STATIONS (CGPS) AND/OR CONTINUOUS REFERENCE STATIONS (CORS) MLFP AND PPBF BEING NORTH 53°20'17.65" WEST AS DERIVED FROM GEODETIC VALUES PUBLISHED BY THE CALIFORNIA SPACIAL REFERENCE CENTER (CSRC) AND/OR NATIONAL GEODETIC SURVEY (NGS), RESPECTIVELY.

HUITT-ZOLLARS
 Ontario
 3990 CONCOURS, SUITE 330 • ONTARIO, CALIFORNIA 91764 • (909) 941-7799
 PREPARED UNDER THE SUPERVISION OF:
 JOHNNY MURAD
 R.C.E. NO. 67512 EXP. 6/30/23

COUNTY OF RIVERSIDE

CONCEPTUAL GRADING, DRAINAGE & UTILITY PLAN
TCC - KNOX VIII
HARLEY KNOX BLVD, DECKER RD & ROWLAND LANE

DESIGNED BY: J.M.
 DRAWN BY: H-Z STAFF
 CHECKED BY: J.M.
 FIELD BOOK: _____

SHEET **1** OF **2** SHEETS

JOB NO. R313684.01

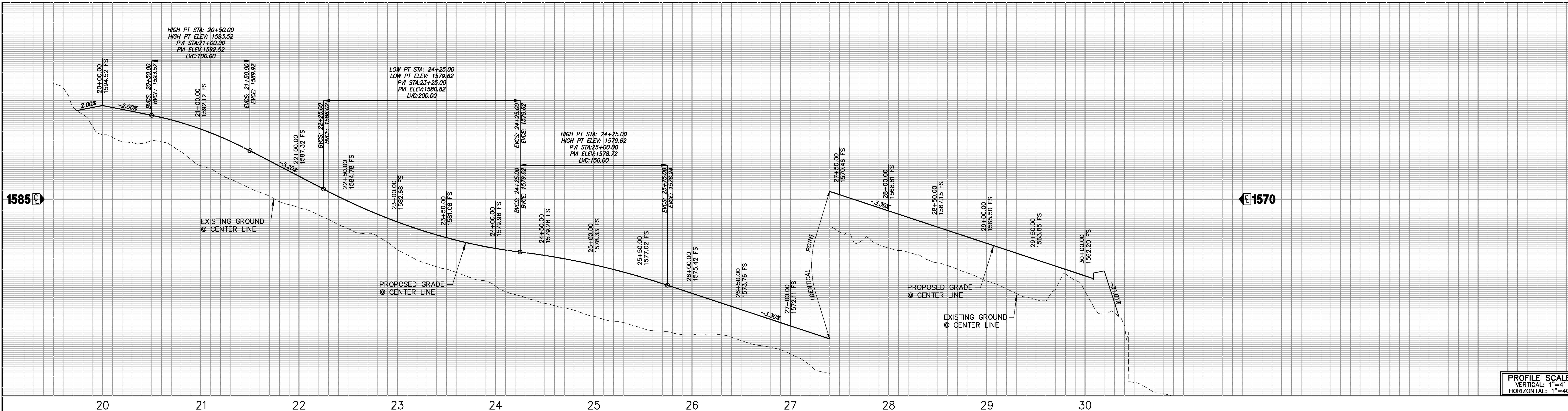

PROFILE SCALE
 VERTICAL: 1"=4'
 HORIZONTAL: 1"=40'

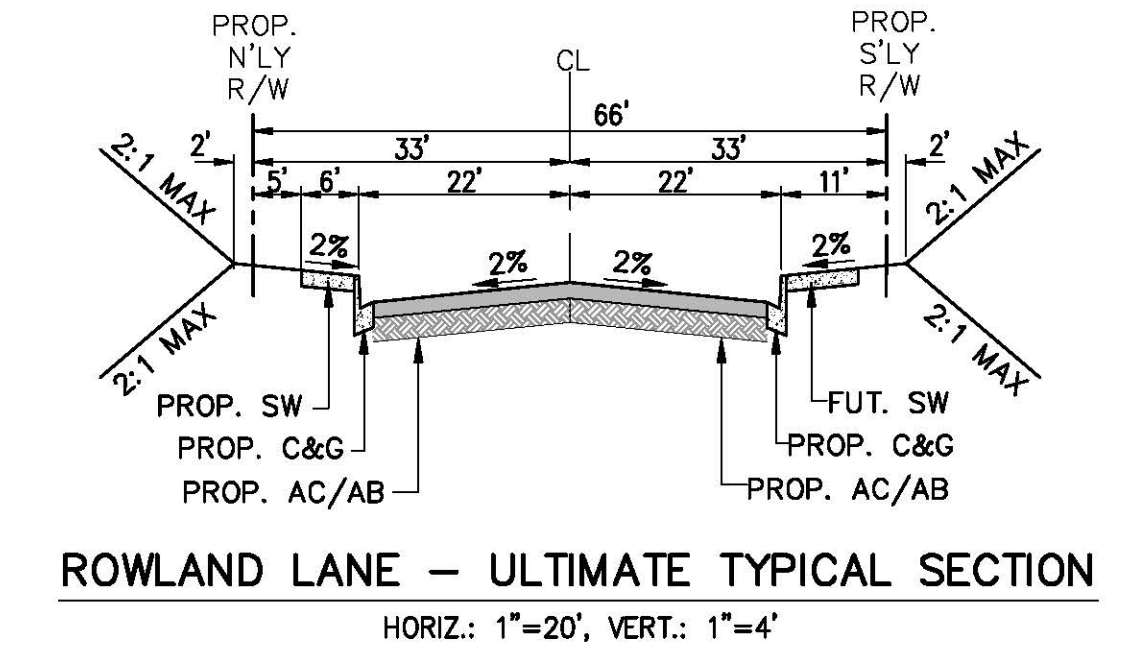
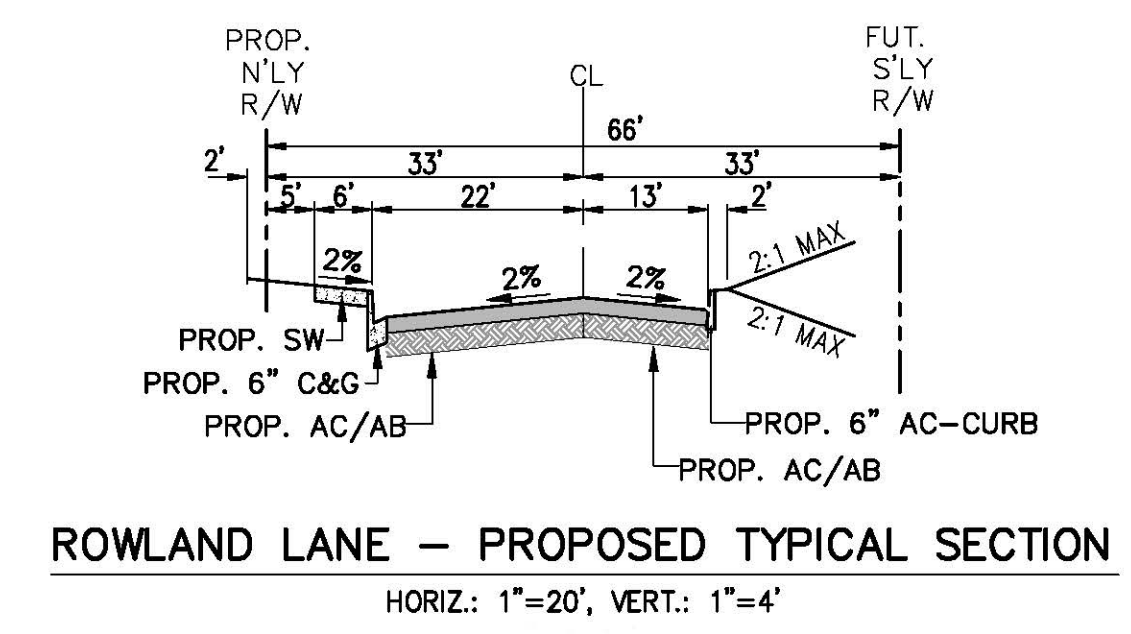
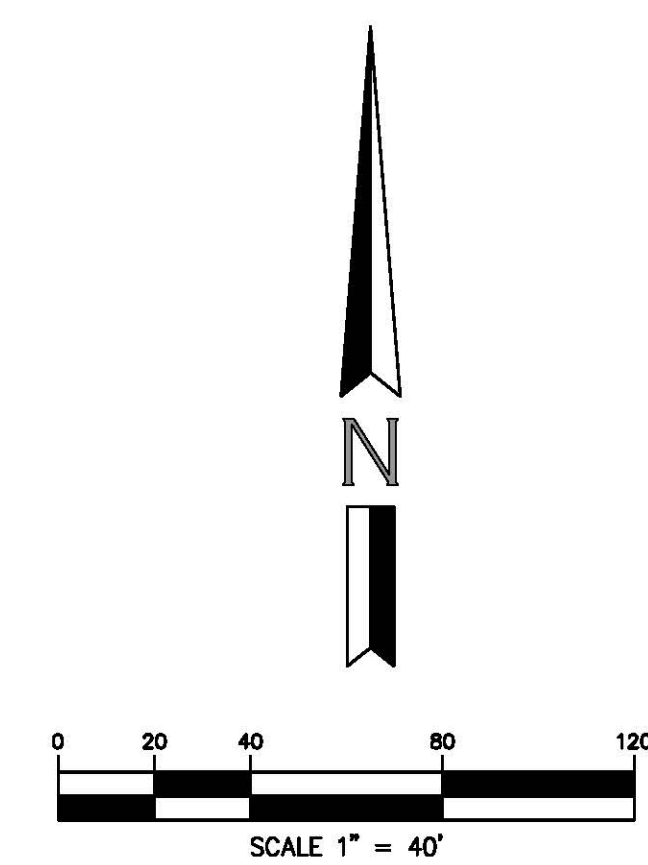
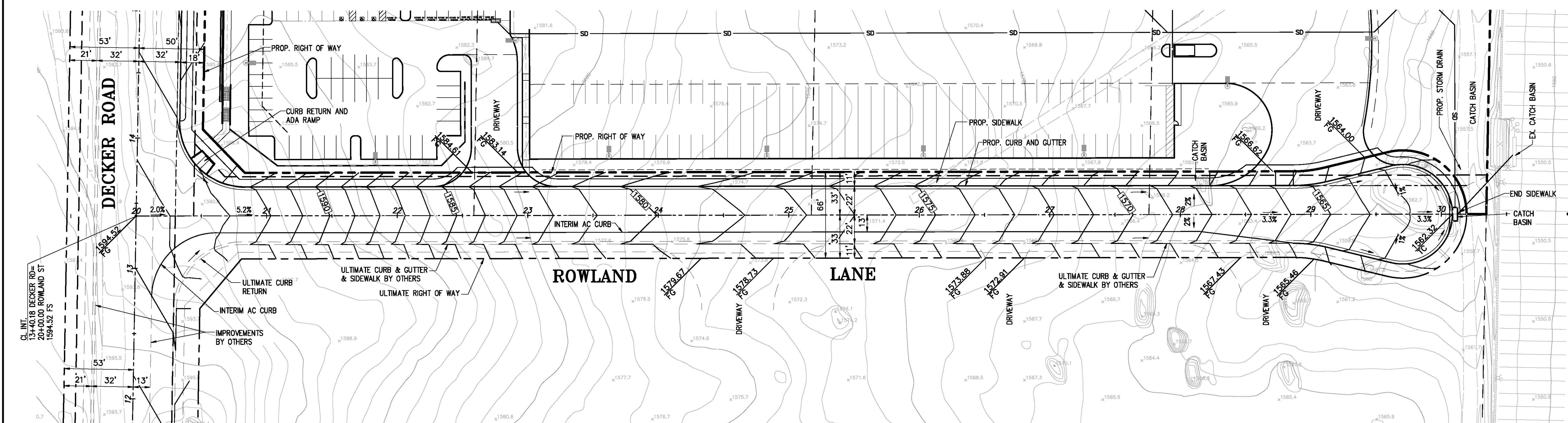

HUITT-ZOLLARS
 Huitt-Zollars, Inc. Ontario
 3990 CONCOURS, SUITE 330 • ONTARIO, CALIFORNIA 91764 • (909) 941-7799
 PREPARED UNDER THE SUPERVISION OF:
 JOHNNY MURAD
 R.C.E. NO. 67512 EXP. 6/30/23 DATE

COUNTY OF RIVERSIDE
CONCEPTUAL STREET PLAN & PROFILE
TCC - KNOX VIII
FOR
ROWLAND LANE
TENTATIVE PARCEL MAP 38172

DESIGNED BY J.M.	SHEET 2
DRAWN BY H-Z STAFF	OF 2
CHECKED BY J.M.	SHEETS
FIELD BOOK	JOB NO. R313684.01

Appendix 3: Soils Information

Geotechnical Study and Other Infiltration Testing Data

September 10, 2020

Trammell Crow So. Cal. Development
3501 Jamboree Road, Suite 230
Newport Beach, California 92660



SOUTHERN
CALIFORNIA
GEOTECHNICAL
A California Corporation

Attention: Mr. Neal Holdridge
Principal/Environmental Manager

Project No.: **20G183-2**

Subject: **Results of Infiltration Testing**
Proposed Warehouse – Knox VII
SEC Harley Knox Boulevard and Decker Road
Riverside County, California

Reference: Geotechnical Investigation, Proposed Warehouse – Knox VII, SEC Harley Knox Boulevard and Decker Road, Riverside County, California, prepared by Southern California Geotechnical, Inc. (SCG) for Trammell Crow So. Cal. Development, SCG Project No. 20G183-1.

Mr. Holdridge:

In accordance with your request, we have conducted infiltration testing at the subject site. We are pleased to present this report summarizing the results of the infiltration testing and our design recommendations.

Scope of Services

The scope of services performed for this project was in general accordance with our Proposal No. 20P291, dated July 22, 2020. The scope of services included site reconnaissance, subsurface exploration, field and laboratory testing, and engineering analysis to determine the infiltration rates of the onsite soils. The infiltration testing was performed in general accordance with ASTM Test Method D-3385-03, Standard Test Method for Infiltration Rate of Soils in Field Using Double Ring Infiltrometer.

Site and Project Description

The subject site is located at the southeast corner of Harley Knox Boulevard and the future continuation of Decker Road in an unincorporated portion of Riverside County near Perris, California. The site is bounded to the north by Harley Knox Boulevard, to the west by the Decker Road easement, to the south by a vacant lot, and to the east by an existing warehouse.

The site consists of five (5) contiguous parcels totaling, 13.6± acres in size. Based on aerial photographs obtained from Google Earth and site visitation, the site is vacant and undeveloped. The ground surface cover consists of exposed soil with sparse to moderate native grass and weed growth. Several tonalitic bedrock outcrops are exposed throughout the site, with heavier concentrations occurring in the northeast and eastern portions of the site.

Detailed topographic information was not available at the time of this report. However, based on topographic information obtained from Google Earth, the overall site topography slopes gently to the east at a gradient of 3± percent.

Proposed Development

Based on a conceptual site plan (Scheme 3) that was provided to our office, the site will be developed with one (1) warehouse. The new building will be located in the north-central area of the site and will be 256,048± ft² in size. The building will be constructed with dock-high doors along a portion of the southern building wall. It is expected that the building will be surrounded by asphaltic concrete pavements in the parking and drive lane areas, and Portland cement concrete pavements in truck traffic areas, with concrete flatwork and landscape planter areas limited throughout the site.

Based on the site plan, the development will utilize on-site infiltration for stormwater disposal. The infiltration system will consist of a detention basin located in the eastern area of the site. We understand that the bottom of the basin will be approximately 7 to 8± feet below existing site grades.

Concurrent Study

SCG performed a geotechnical investigation at the subject site. The subsurface exploration conducted for this project consisted of four (4) borings advanced to depths of 8½ to 25± feet below the existing site grades and four (4) trenches excavated to depths of 3 to 11± feet. Some of the borings and trenches were terminated at shallower depths than originally proposed after encountering very dense bedrock. Artificial fill soils were encountered at the ground surface at Boring No. B-1 and at Trench No. T-1, extending to depths of 1 to 1½± feet below the existing site grades. The fill soils generally consist of loose to medium dense silty fine to medium sands with varying coarse sand content. Older alluvium was encountered beneath the existing fill soils and at the ground surface at all of the boring and trench locations, extending to depths of 3 to 6± feet below the existing site grades. The older alluvium generally consists of medium dense to very dense clayey fine sands with varying medium to coarse sand and silt content, and silty fine sands with varying medium to coarse sand and clay content. Val Verde Tonalite bedrock was encountered beneath the older alluvial soils at all of the boring and trench locations, extending to at least the maximum depth explored of 25± feet below the existing site. The bedrock consists of very dense, light gray brown to gray brown fine to coarse grained tonalite. These materials are generally weathered and friable throughout the depths explored at the site. However, auger refusal conditions were encountered at depths of 8½ and 17± feet on very dense tonalite bedrock materials at Boring Nos. B-2 and B-4, respectively.

Groundwater

Free water was not encountered during the drilling of any of the borings. Based on the lack of any water within the borings, and the moisture contents of the recovered soil samples, the static groundwater table is considered to have existed at a depth in excess of 25± feet below the existing site grades, at the time of the subsurface investigation.

As part of our research, we reviewed available groundwater data in order to determine the historic high groundwater level for the site. The primary reference used to determine the historic groundwater depths in this area is the Western Municipal Water District and the San Bernardino Valley Water Conservation District Cooperative Well Measuring Program. High water level from the nearest well is included below:

State Well ID	Approximate Distance from Subject Site	High Water Level MSL (feet)
03S/04W-36K/Q	< 3,600 feet	1,430.20

Based on topographic information obtained from Google Earth, the elevation at the subject site ranges from 1,558± feet msl in the northeastern area of the site to 1,597± feet msl in the southwestern region of the site. The elevation of the high-water level in the well is 1,430± feet msl.

Recent water level data was obtained from the California State Water Resources Control Board, GeoTracker, website, <http://geotracker.waterboards.ca.gov/>. A series of nearby monitoring wells (identified as MW-1 through MW-5) on record are located approximately 2,500-3,000 feet north of the site at elevations ranging from 1,535 feet msl to 1,560 feet msl. Water level readings within these monitoring wells indicate high groundwater levels of 6.29± to 25.8 feet below the ground surface in May 2011.

Based on this well data, the depth of the high water level at the subject site, measured from the lowest elevation at the subject site, is 30± feet below the existing site grades. Therefore, a groundwater depth of 30± feet is considered to be conservative with respect to the more recent site conditions.

Subsurface Exploration

Scope of Exploration

The subsurface exploration for the infiltration testing consisted of two (2) backhoe-excavated trenches, extending to depths of 7 to 8± feet below existing site grades. The trenches were logged during excavation by a member of our staff. The approximate locations of the infiltration trenches (identified as I-1 and I-2) are indicated on the Infiltration Test Location Plan, enclosed as Plate 2 of this report.

Geotechnical Conditions

Artificial Fill

Artificial fill was encountered at the ground surface of Infiltration Test No. I-1. The artificial fill soils consist of medium dense silty fine sands with trace to little medium to coarse sands extending to 1± feet below existing site grades.

Older Alluvium

Old alluvium was encountered at the ground surface of Infiltration Test No. I-2 and beneath the artificial fill at I-1, extending to the maximum explored depth of 8± feet below existing site grades. The native alluvial soils consist of dense clayey fine to coarse sands, and clayey fine to medium sands. Trace quantities of fine gravel and little fine root fibers were encountered within the alluvium.

Bedrock

Tonalite bedrock was encountered beneath the older alluvium at Infiltration Test No. I-2 at a depth of 8± feet below existing site grades. The encountered tonalite was very dense, slightly weathered, phaneritic, and fine to coarse grained.

Infiltration Testing

We understand that the results of the testing will be used to prepare a preliminary design for the storm water infiltration system that will be used at the subject site. As previously mentioned, the infiltration testing was performed in general accordance with ASTM Test Method D-3385-03, Standard Test Method for Infiltration Rate of Soils in Field Using Double Ring Infiltrometer.

Two stainless steel infiltration rings were used for the infiltration testing. The outer infiltration ring is 2 feet in diameter and 20 inches in height. The inner infiltration ring is 1 foot in diameter and 20 inches in height. At the test locations, the outer ring was driven 3± inches into the soil at the base of each trench. The inner ring was centered inside the outer ring and subsequently driven 3± inches into the soil at the base of the trench. The rings were driven into the soil using a ten-pound sledge hammer. The soil surrounding the wall of the infiltration rings was only slightly disturbed during the driving process.

Infiltration Testing Procedure

Infiltration testing was performed at two (2) trench locations (identified as Infiltration Test Nos. I-1 and I-2). The infiltration testing consisted of filling the inner ring and the annular space (the space between the inner and outer rings) with water, approximately 3 to 4 inches above the soil. To prevent the flow of water from one ring to the other, the water level in both the inner ring and the annular space between the rings was maintained using constant-head float valves. The volume of water that was added to maintain a constant head in the inner ring and the annular space during each time interval was determined and recorded. A cap was placed over the rings to minimize the evaporation of water during the tests.

The schedule for readings was determined based on the observed soil type at the base of each backhoe-excavated trench. Based on the existing soils at the trench locations, the volumetric measurements were made at 30-minute increments. The water volume measurements are presented on the spreadsheets enclosed with this report. The infiltration rates for each of the timed intervals are also tabulated on these spreadsheets.

The Infiltration rates for the Infiltration tests are calculated In centimeters per hour and then converted to inches per hour. The rates are summarized below:

<u>Infiltration Test No.</u>	<u>Depth (feet)</u>	<u>Soil Description</u>	<u>Infiltration Rate (inches/hour)</u>
I-1	8	Clayey fine to medium Sand, trace coarse Sand	1.2
I-2	7	Clayey fine to coarse Sand	0.2

Laboratory Testing

Moisture Content

The moisture contents for selected soil samples within the trenches were determined in accordance with ASTM D-2216 and are expressed as a percentage of the dry weight. These test results are presented on the Trench Logs.

Grain Size Analysis

The grain size distribution of selected soils collected from the base of each infiltration test trench has been determined using a range of wire mesh screens. These tests were performed in general accordance with ASTM D-422 and/or ASTM D-1140. The weight of the portion of the sample retained on each screen is recorded and the percentage finer or coarser of the total weight is calculated. The results of the grainsize analysis are presented on Plates C-1 through C-2 of this report.

Design Recommendations

Two (2) infiltration tests were performed at the subject site. As noted above, the calculated infiltration rates at the infiltration test locations range between 1.2 and 0.2 inches per hour. **Based on the results of the testing, infiltration is not considered feasible at this site. The primary factor controlling the low infiltration rates is the clay content of the alluvial soils and the shallow depth to bedrock.**

General Comments

This report has been prepared as an instrument of service for use by the client in order to aid in the evaluation of this property and to assist the architects and engineers in the design and preparation of the project plans and specifications. This report may be provided to the contractor(s) and other design consultants to disclose information relative to the project. However, this report is not intended to be utilized as a specification in and of itself, without appropriate interpretation by the project architect, structural engineer, and/or civil engineer. The design of the infiltration system is the responsibility of the civil engineer. The role of the geotechnical engineer is limited to determination of infiltration rate only. By using the design

Infiltration rates contained herein, the civil engineer agrees to indemnify, defend, and hold harmless the geotechnical engineer for all aspects of the design and performance of the infiltration system. The reproduction and distribution of this report must be authorized by the client and Southern California Geotechnical, Inc. Furthermore, any reliance on this report by an unauthorized third party is at such party's sole risk, and we accept no responsibility for damage or loss which may occur. The analysis of this site was based on a subsurface profile interpolated from limited discrete soil samples. While the materials encountered in the project area are considered to be representative of the total area, some variations should be expected between trench locations and testing depths. If the conditions encountered during construction vary significantly from those detailed herein, we should be contacted immediately to determine if the conditions alter the recommendations contained herein.

This report has been based on assumed or provided characteristics of the proposed development. It is recommended that the owner, client, architect, structural engineer, and civil engineer carefully review these assumptions to ensure that they are consistent with the characteristics of the proposed development. If discrepancies exist, they should be brought to our attention to verify that they do not affect the conclusions and recommendations contained herein. We also recommend that the project plans and specifications be submitted to our office for review to verify that our recommendations have been correctly interpreted. The analysis, conclusions, and recommendations contained within this report have been promulgated in accordance with generally accepted professional geotechnical engineering practice. No other warranty is implied or expressed.

Closure

We sincerely appreciate the opportunity to be of service on this project. We look forward to providing additional consulting services during the course of the project. If we may be of further assistance in any manner, please contact our office.

Respectfully Submitted,

SOUTHERN CALIFORNIA GEOTECHNICAL, INC.



Ryan Bremer
Staff Geologist



Gregory K. Mitchell, GE 2364
Principal Engineer



Distribution: (1) Addressee

Enclosures: Plate 1 - Site Location Map
Plate 2 - Infiltration Test Location Plan
Trench Logs (2 pages)
Infiltration Test Results Spreadsheets (2 pages)
Grain Size Distribution Graphs (2 pages)



SOURCE: USGS TOPOGRAPHIC MAP OF THE STEELE PEAK QUADRANGLE, RIVERSIDE, CALIFORNIA, 2018.



SITE LOCATION MAP

PROPOSED WAREHOUSE - KNOX VII
RIVERSIDE COUNTY, CALIFORNIA

SCALE: 1" = 2000'

DRAWN: J.L.

CHKD: GKM

SCG PROJECT

20G183-2

PLATE 1



**SOUTHERN
CALIFORNIA
GEOTECHNICAL**

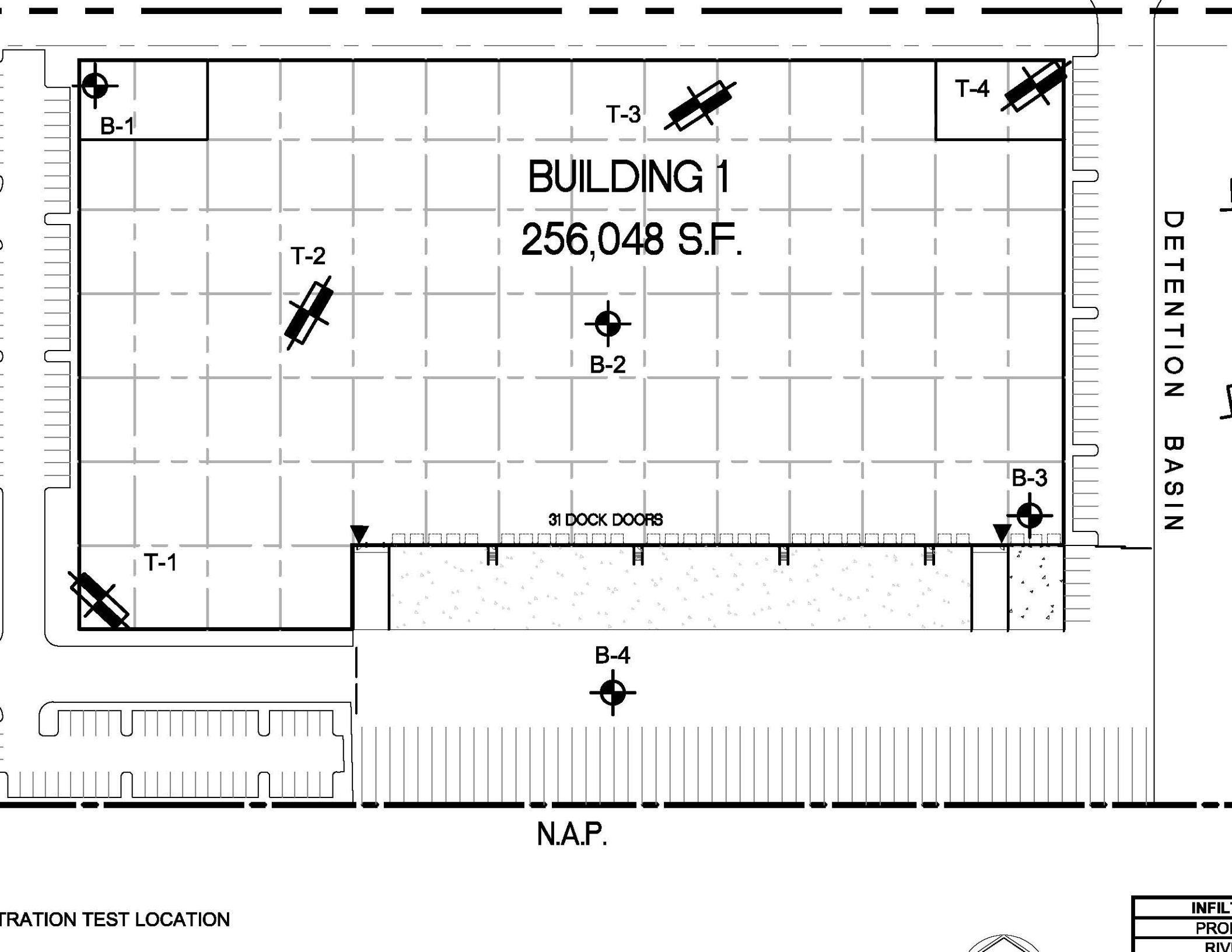

INTEGRATION TEST LOCATION

INFIL
PROF
RIV

SOUTHERN CALIFORNIA GEOTECHNICAL

**TRENCH NO.
I-1**

JOB NO.: 20G183-2

EQUIPMENT USED: Backhoe

WATER DEPTH: Dry

PROJECT: Proposed Warehouse - Knox VII

LOGGED BY: Ryan Bremer

SEEPAGE DEPTH: Dry

LOCATION: Riverside County, California

ORIENTATION: S 2 E

READINGS TAKEN: At Completion

DATE: 8/20/2020

ELEVATION: —

DEPTH	SAMPLE	DRY DENSITY (PCF)	MOISTURE (%)	EARTH MATERIALS DESCRIPTION	GRAPHIC REPRESENTATION
<div style="text-align: center;">5</div> <div style="text-align: center;">10</div> <div style="text-align: center;">15</div>	b		g	<p>A: FILL: Brown Silty fine Sand, trace to little medium to coarse Sand, some fine root fibers, medium dense-dry</p> <p>B: OLDER ALLUVIUM: Red Brown Clayey fine to coarse Sand, little fine root fibers, dense-moist</p> <p>C: OLDER ALLUVIUM: Orange Brown Clayey fine to medium Sand, trace coarse Sand, micaceous, dense-moist</p> <p style="text-align: center;">Trench Terminated @ 8 feet</p>	<p>S 2 E →</p> <p>SCALE: 1" = 5'</p>

KEY TO SAMPLE TYPES:
 B - BULK SAMPLE (DISTURBED)
 R - RING SAMPLE 2-1/2" DIAMETER
 (RELATIVELY UNDISTURBED)

TRENCH LOG

PLATE B-1

SOUTHERN CALIFORNIA GEOTECHNICAL

**TRENCH NO.
I-2**

JOB NO.: 20G183-2	EQUIPMENT USED: Backhoe	WATER DEPTH: Dry
PROJECT: Proposed Warehouse - Knox VII	LOGGED BY: Ryan Bremer	SEEPAGE DEPTH: Dry
LOCATION: Riverside County, California	ORIENTATION: S 10 E	READINGS TAKEN: At Completion
DATE: 8/20/2020	ELEVATION: --	

DEPTH	SAMPLE	DRY DENSITY (PCF)	MOISTURE (%)	EARTH MATERIALS DESCRIPTION	GRAPHIC REPRESENTATION
<div style="text-align: center;">5</div> <div style="text-align: center;">10</div> <div style="text-align: center;">15</div>	b		9	<p>A: OLDER ALLUVIUM: Red Brown Clayey fine to medium Sand, trace coarse Sand, little fine root fibers, dense-dry</p> <p>B: OLDER ALLUVIUM: Red Brown Clayey fine to coarse Sand, trace fine Gravel, dense-damp to moist</p> <p>C: OLDER ALLUVIUM: Orange Brown Clayey fine to coarse Sand, very dense-moist</p> <p>D: VAL VEDRE TONALITE: Light Gray Brown to Gray Brown fine to coarse grained Tonalite bedrock, phaneritic, slightly weathered, very dense-moist</p> <p style="text-align: center;">Trench Terminated @ 8 feet</p>	<p>S 10 E →</p> <p>SCALE: 1" = 5'</p>

KEY TO SAMPLE TYPES:
 B - BULK SAMPLE (DISTURBED)
 R - RING SAMPLE 2-1/2" DIAMETER
 (RELATIVELY UNDISTURBED)

INFILTRATION CALCULATIONS

Project Name	Proposed Warehouse - Knox VII
Project Location	Riverside County, California
Project Number	20G183-2
Engineer	Ryan Bremer

Infiltration Test No I-1

Constants			
	Diameter (ft)	Area (ft ²)	Area (cm ²)
Inner	1	0.79	730
Anlr. Spac	2	2.36	2189

*Note: The infiltration rate was calculated based on current time interval

Test Interval		Time (hr)	Interval Elapsed (min)	Flow Readings				Infiltration Rates			
				Inner Ring (ml)	Ring Flow (cm ³)	Annular Ring (ml)	Space Flow (cm ³)	Inner Ring* (cm/hr)	Annular Space* (cm/hr)	Inner Ring* (in/hr)	Annular Space* (in/hr)
1	Initial	9:45 AM	30	0	100	0	300	0.27	0.27	0.11	0.11
	Final	10:15 AM	30	100		300					
2	Initial	10:15 AM	30	0	250	0	800	0.69	0.73	0.27	0.29
	Final	10:45 AM	60	250		800					
3	Initial	10:45 AM	30	0	400	0	100	1.10	0.09	0.43	0.04
	Final	11:15 AM	90	400		100					
4	Initial	11:15 AM	30	0	900	0	2200	2.47	2.01	0.97	0.79
	Final	11:45 AM	120	900		2200					
5	Initial	11:45 AM	30	0	1200	0	2400	3.29	2.19	1.30	0.86
	Final	12:15 PM	150	1200		2400					
6	Initial	12:15 PM	30	0	1200	0	2400	3.29	2.19	1.30	0.86
	Final	12:45 PM	180	1200		2400					
7	Initial	12:45 PM	30	0	1150	0	2200	3.15	2.01	1.24	0.79
	Final	1:15 PM	210	1150		2200					

INFILTRATION CALCULATIONS

Project Name	Proposed Warehouse - Knox VII
Project Location	Riverside County, California
Project Number	20G183-2
Engineer	Ryan Bremer

Infiltration Test No I-2

Constants			
	Diameter (ft)	Area (ft ²)	Area (cm ²)
Inner	1	0.79	730
Anlr. Spac	2	2.36	2189

*Note: The infiltration rate was calculated based on current time interval

Test Interval		Time (hr)	Interval Elapsed (min)	Flow Readings				Infiltration Rates			
				Inner Ring (ml)	Ring Flow (cm ³)	Annular Ring (ml)	Space Flow (cm ³)	Inner Ring* (cm/hr)	Annular Space* (cm/hr)	Inner Ring* (in/hr)	Annular Space* (in/hr)
1	Initial	11:10 AM	30	0	50	0	0	0.14	0.00	0.05	0.00
	Final	11:40 AM	30	50		0					
2	Initial	11:40 AM	30	50	150	0	0	0.41	0.00	0.16	0.00
	Final	12:10 PM	60	200		0					
3	Initial	12:10 PM	30	200	200	0	0	0.55	0.00	0.22	0.00
	Final	12:40 PM	90	400		0					
4	Initial	12:40 PM	30	400	200	0	0	0.55	0.00	0.22	0.00
	Final	1:10 PM	120	600		0					
5	Initial	1:10 PM	30	600	200	0	0	0.55	0.00	0.22	0.00
	Final	1:40 PM	150	800		0					
6	Initial	1:40 PM	30	800	200	0	0	0.55	0.00	0.22	0.00
	Final	2:10 PM	180	1000		0					

Grain Size Distribution

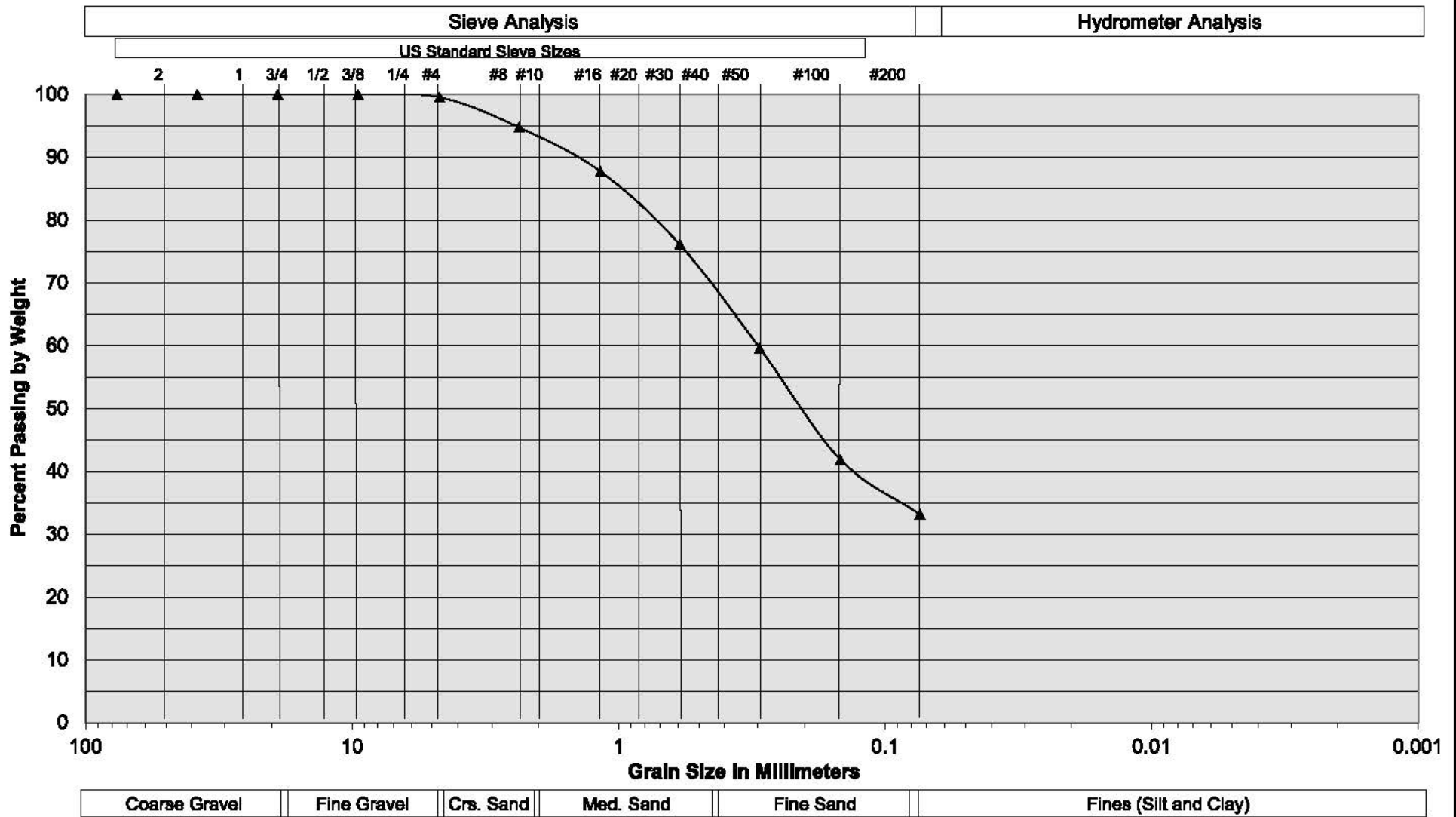

Sample Description	I-1 @ 8'
Soil Classification	Orange Brown Clayey fine to medium Sand, trace coarse Sand

Proposed Warehouse - Knox VII
 Riverside County, California
 Project No. 20G183-2
PLATE C- 1



SOUTHERN CALIFORNIA GEOTECHNICAL
A California Company

Grain Size Distribution

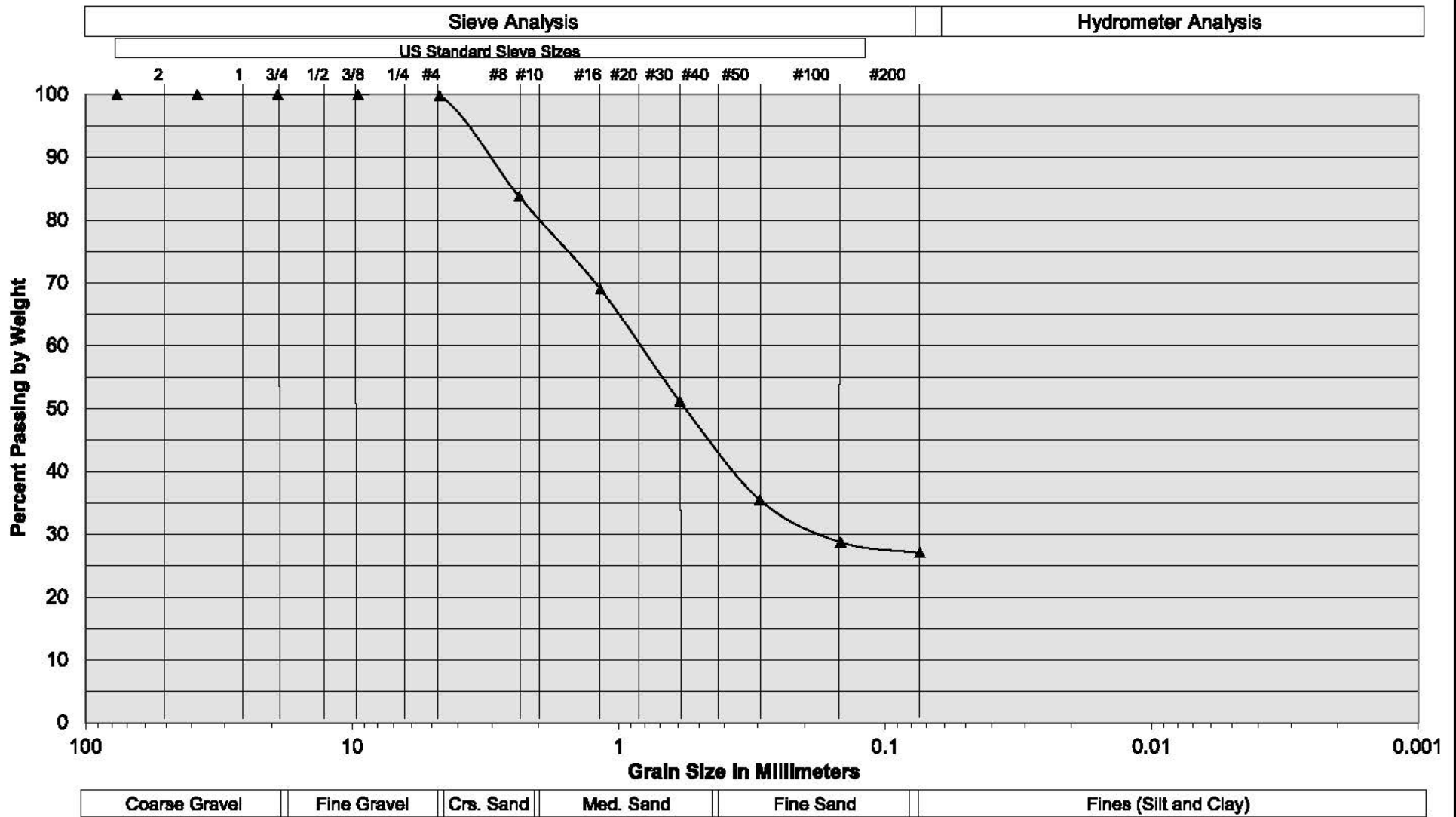

Sample Description	I-2 @ 7'
Soil Classification	Orange Brown Clayey fine to coarse Sand

Proposed Warehouse - Knox VII
 Riverside County, California
 Project No. 20G183-2
PLATE C-2



Appendix 4: Historical Site Conditions(N/A)

Phase I Environmental Site Assessment or Other Information on Past Site Use

Appendix 5: LID Infeasibility

LID Technical Infeasibility Analysis

CHAPTER 3: PREPARING YOUR PROJECT-SPECIFIC WQMP

TABLE 3-4. LID BMP Applicability

LID BMP Hierarchy	A	B	C	D
	$K_{SAT} > 1.6"/hr.$, and no restrictions on infiltration	Are Harvest and Use BMPs feasible?	$0.3"/hr. < K_{SAT} < 1.6"/hr.$, or unpredictable or unknown	$K_{SAT} < 0.3"/hr.$
LID Infiltration BMPs*	✓			
Harvest and Use BMPs		✓		✓
LID Bioretention	✓		✓	✓
LID Biotreatment				✓

Notes for Table 3-5:

See also Figure 3-6 for guidance in selecting appropriate BMPs

Column A: Selections from this column may be used in locations where the infiltration rate of underlying soils is at least 1.6" per hour and no restrictions on infiltration apply to these locations.

Column B: Harvest and Use BMPs may be used where it can be shown that there is sufficient demand for harvested water and where LID Infiltration BMPs are not feasible.

Column C: Selections in this column may be used in locations where the measured infiltration rate of underlying soils is between 0.3" and 1.6" per hour or where, in accordance with recommendations of a licensed geotechnical engineer, the post-development saturated hydraulic conductivity is uncertain or unknown or cannot be reliably predicted because of soil disturbance or fill, anisotropic soil characteristics, presence of clay lenses, or other factors.

Column D: Selections in this column may be used in locations where the infiltration rate of underlying soils is 0.3" per hour or less. See Chapter 2 for more information.

* Permeable Pavement, when designed with a maximum of a 2:1 ratio of impervious area to pervious pavement areas, or less, is considered a self-retaining area, and is not considered an LID BMP for the purposes of this table. This table focuses on the 'special case' included in the discussion of 'areas draining to self-retaining areas' above, where a project proponent can choose to design the pervious pavement as a LID BMP in accordance with an approved design, such as the LID BMP Design handbook, and in return drain additional impervious area onto the pervious pavement beyond the 2:1 ratio.

3.4.2.a. Laying out your LID BMPs

Finding the right location for LID BMPs on your site involves a careful and creative integration of several factors:

- ✓ To make the most efficient use of the site and to maximize aesthetic value, **integrate BMPs with site landscaping**. Many local zoning codes may require landscape setbacks or buffers, or may specify that a minimum portion of the site be landscaped. It may be possible to locate some or all of your site's Stormwater BMPs within this same area, or within utility easements or other non-buildable areas.
- ✓ Bioretention BMPs must be **level or nearly level** all the way around. When configured in a linear fashion (similar to swales) bioretention BMPs may be gently sloped end to end, but opposite sides must be at the same

Appendix 6: BMP Design Details

BMP Sizing, Design Details and other Supporting Documentation

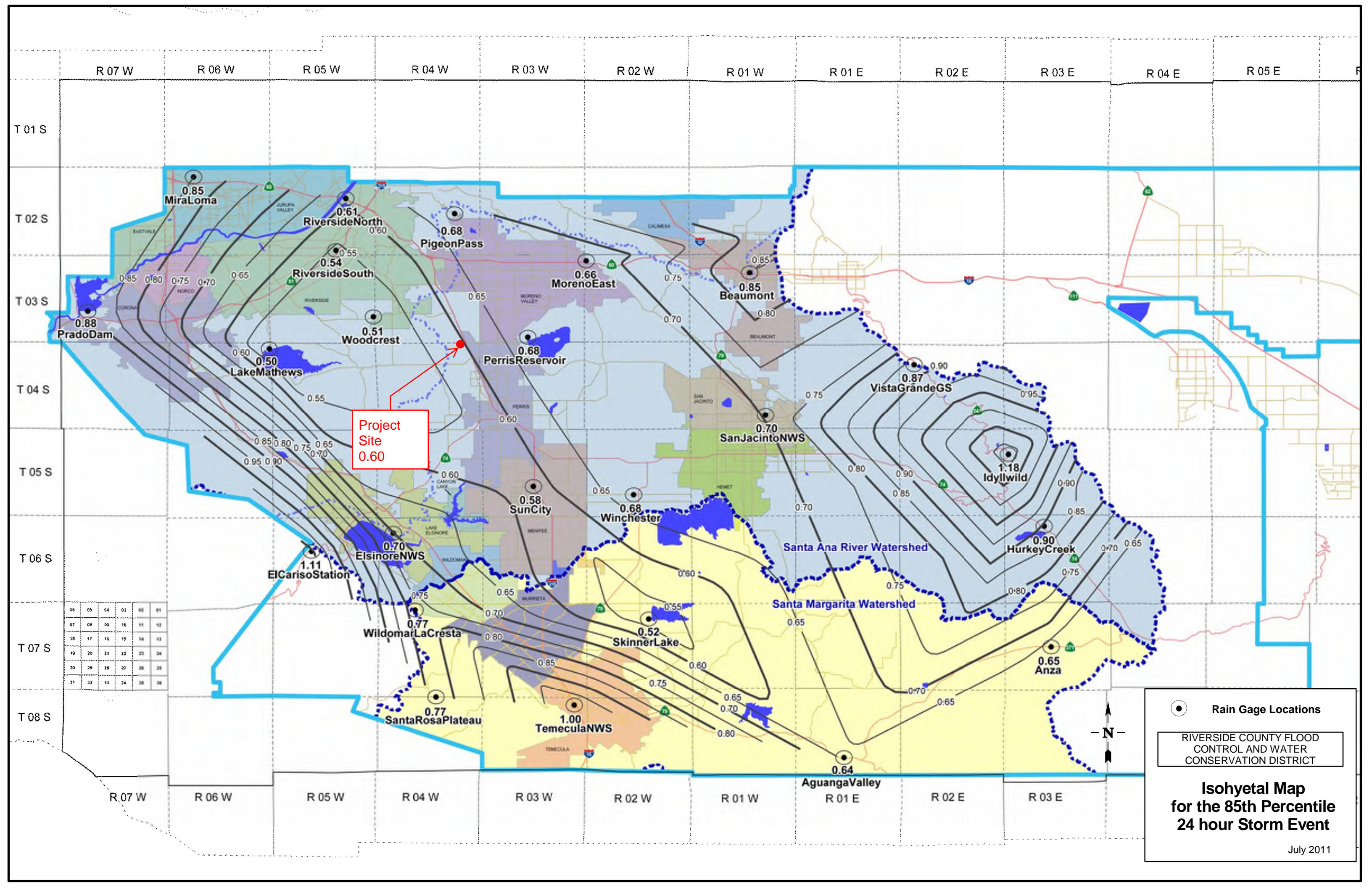

Project Site
0.60

06	05	04	03	02	01
07	09	09	10	11	12
16	17	16	15	14	13
19	20	21	22	23	24
20	29	28	27	26	25
31	32	33	34	35	36

● Rain Gage Locations

RIVERSIDE COUNTY FLOOD CONTROL AND WATER CONSERVATION DISTRICT

Isohyetal Map for the 85th Percentile 24 hour Storm Event

July 2011

Bioretention Facility - Design Procedure		BMP ID For DMA A	Legend:	Required Entries
				Calculated Cells
Company Name:	Huitt-Zollars, Inc		Date:	10/25/2021
Designed by:	dakota stokley		County/City Case No.:	
Design Volume				
Enter the area tributary to this feature			$A_T =$	15.5 acres
Enter V_{BMP} determined from Section 2.1 of this Handbook			$V_{BMP} =$	24,938 ft ³
Type of Bioretention Facility Design				
<input checked="" type="radio"/> Side slopes required (parallel to parking spaces or adjacent to walkways) <input type="radio"/> No side slopes required (perpendicular to parking space or Planter Boxes)				
Bioretention Facility Surface Area				
Depth of Soil Filter Media Layer			$d_S =$	3.0 ft
Top Width of Bioretention Facility, excluding curb			$w_T =$	63.0 ft
Total Effective Depth, d_E $d_E = (0.3) \times d_S + (0.4) \times 1 - (0.7/w_T) + 0.5$			$d_E =$	1.79 ft
Minimum Surface Area, A_m $A_M (ft^2) = \frac{V_{BMP} (ft^3)}{d_E (ft)}$			$A_M =$	13,941 ft ²
Proposed Surface Area			$A =$	14,244 ft ²
Bioretention Facility Properties				
Side Slopes in Bioretention Facility			$z =$	4 :1
Diameter of Underdrain				6 inches
Longitudinal Slope of Site (3% maximum)				0.5 %
6" Check Dam Spacing				0 feet
Describe Vegetation:			Natural Grasses	
Notes:				

3.5 Bioretention Facility

Type of BMP	LID – Bioretention
Treatment Mechanisms	Infiltration, Evapotranspiration, Evaporation, Biofiltration
Maximum Drainage Area	This BMP is intended to be integrated into a project’s landscaped area in a distributed manner. Typically, contributing drainage areas to Bioretention Facilities range from less than 1 acre to a maximum of around 10 acres.
Other Names	Rain Garden, Bioretention Cell, Bioretention Basin, Biofiltration Basin, Landscaped Filter Basin, Porous Landscape Detention

Description

Bioretention Facilities are shallow, vegetated basins underlain by an engineered soil media. Healthy plant and biological activity in the root zone maintain and renew the macro-pore space in the soil and maximize plant uptake of pollutants and runoff. This keeps the Best Management Practice (BMP) from becoming clogged and allows more of the soil column to function as both a sponge (retaining water) and a highly effective and self-maintaining biofilter. In most cases, the bottom of a Bioretention Facility is unlined, which also provides an opportunity for infiltration to the extent the underlying onsite soil can accommodate. When the infiltration rate of the underlying soil is exceeded, fully biotreated flows are discharged via underdrains. Bioretention Facilities therefore will inherently achieve the maximum feasible level of infiltration and evapotranspiration and achieve the minimum feasible (but highly biotreated) discharge to the storm drain system.

Siting Considerations

These facilities work best when they are designed in a relatively level area. Unlike other BMPs, Bioretention Facilities can be used in smaller landscaped spaces on the site, such as:

- ✓ Parking islands
- ✓ Medians
- ✓ Site entrances

Landscaped areas on the site (such as may otherwise be required through minimum landscaping ordinances), can often be designed as Bioretention Facilities. This can be accomplished by:

- *Depressing* landscaped areas below adjacent impervious surfaces, rather than elevating those areas
- Grading the site to direct runoff from those impervious surfaces *into* the Bioretention Facility, rather than away from the landscaping
- Sizing and designing the depressed landscaped area as a Bioretention Facility as described in this Fact Sheet

Bioretention Facilities should however not be used downstream of areas where large amounts of sediment can clog the system. Placing a Bioretention Facility at the toe of a steep slope should also be avoided due to the potential for clogging the engineered soil media with erosion from the slope, as well as the potential for damaging the vegetation.

Design and Sizing Criteria

The recommended cross section necessary for a Bioretention Facility includes:

- Vegetated area
- 18' minimum depth of engineered soil media
- 12' minimum gravel layer depth with 6' perforated pipes (added flow control features such as orifice plates may be required to mitigate for HCOC conditions)

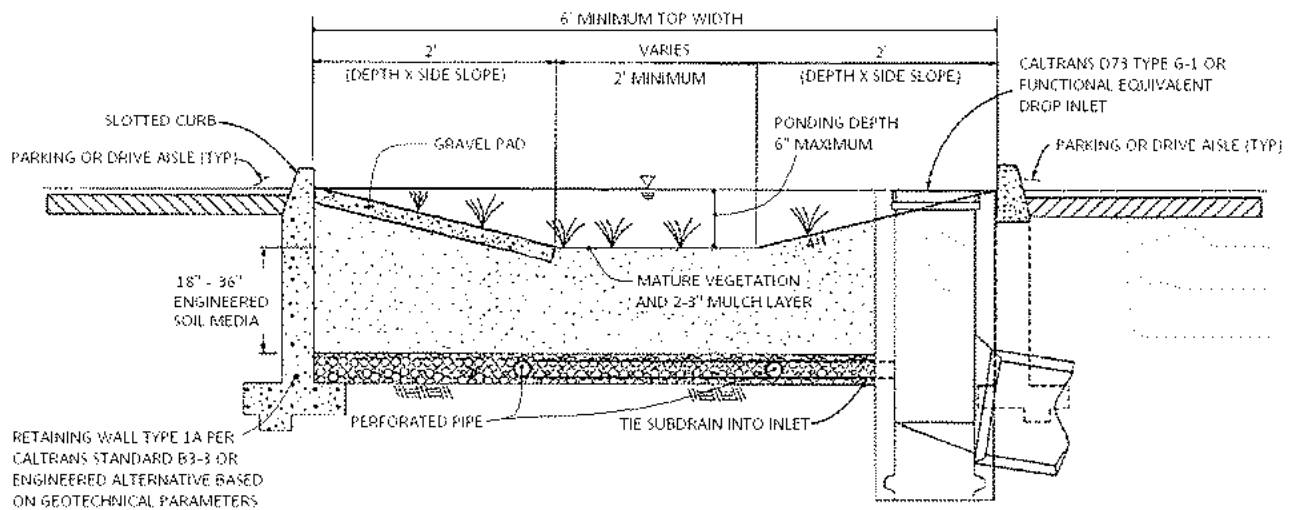

While the 18-inch minimum engineered soil media depth can be used in some cases, it is recommended to use 24 inches or a preferred 36 inches to provide an adequate root zone for the chosen plant palette. Such a design also provides for improved removal effectiveness for nutrients. The recommended ponding depth inside of a Bioretention Facility is 6 inches; measured from the flat bottom surface to the top of the water surface as shown in Figure 1.

Because this BMP is filled with an engineered soil media, pore space in the soil and gravel layer is assumed to provide storage volume. However, several considerations must be noted:

- Surcharge storage above the soil surface (6 inches) is important to assure that design flows do not bypass the BMP when runoff exceeds the soil's absorption rate.
- In cases where the Bioretention Facility contains engineered soil media deeper than 36 inches, the pore space within the engineered soil media can only be counted to the 36-inch depth.
- A maximum of 30 percent pore space can be used for the soil media whereas a maximum of 40 percent pore space can be use for the gravel layer.

Figure 1: Standard Layout for a Bioretention Facility

BIORETENTION FACILITY BMP FACT SHEET

Engineered Soil Media Requirements

The engineered soil media shall be comprised of 85 percent mineral component and 15 percent organic component, by volume, drum mixed prior to placement. The mineral component shall be a Class A sandy loam topsoil that meets the range specified in Table 1 below. The organic component shall be nitrogen stabilized compost¹, such that nitrogen does not leach from the media.

Table 1: Mineral Component Range Requirements

Percent Range	Component
70-80	Sand
15-20	Silt
5-10	Clay

The trip ticket, or certificate of compliance, shall be made available to the inspector to prove the engineered mix meets this specification.

Vegetation Requirements

Vegetative cover is important to minimize erosion and ensure that treatment occurs in the Bioretention Facility. The area should be designed for at least 70 percent mature coverage throughout the Bioretention Facility. To prevent the BMP from being used as walkways, Bioretention Facilities shall be planted with a combination of small trees, densely planted shrubs, and natural grasses. Grasses shall be native or ornamental; preferably ones that do not need to be mowed. The application of fertilizers and pesticides should be minimal. To maintain oxygen levels for the vegetation and promote biodegradation, it is important that vegetation not be completely submerged for any extended period of time. Therefore, a maximum of 6 inches of ponded water shall be used in the design to ensure that plants within the Bioretention Facility remain healthy.

A 2 to 3-inch layer of standard shredded aged hardwood mulch shall be placed as the top layer inside the Bioretention Facility. The 6-inch ponding depth shown in Figure 1 above shall be measured from the top surface of the 2 to 3-inch mulch layer.

Curb Cuts

To allow water to flow into the Bioretention Facility, 1-foot-wide (minimum) curb cuts should be placed approximately every 10 feet around the perimeter of the Bioretention Facility. Figure 2 shows a curb cut in a Bioretention Facility. Curb cut flow lines must be at or above the V_{BMP} water surface level.

¹ For more information on compost, visit the US Composting Council website at: <http://compostingcouncil.org/>

BIORETENTION FACILITY BMP FACT SHEET



Figure 2: Curb Cut located in a Bioretention Facility

To reduce erosion, a gravel pad shall be placed at each inlet point to the Bioretention Facility. The gravel should be 1- to 1.5-inch diameter in size. The gravel should overlap the curb cut opening a minimum of 6 inches. The gravel pad inside the Bioretention Facility should be flush with the finished surface at the curb cut and extend to the bottom of the slope.

In addition, place an apron of stone or concrete, a foot square or larger, inside each inlet to prevent vegetation from growing up and blocking the inlet. See Figure 3.

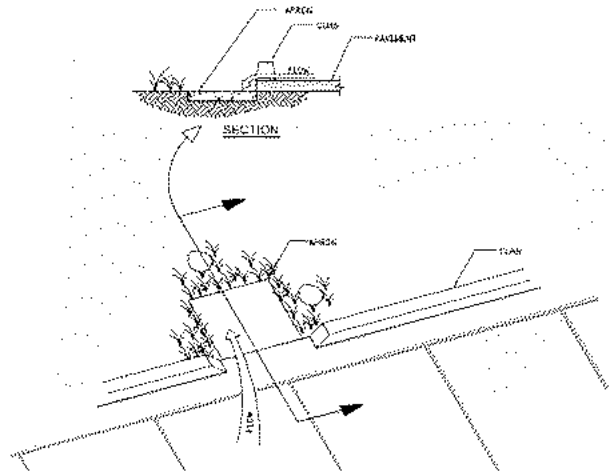

Figure 3: Apron located in a Bioretention Facility

Terracing the Landscaped Filter Basin

It is recommended that Bioretention Facilities be level. In the event the facility site slopes and lacks proper design, water would fill the lowest point of the BMP and then discharge from the basin without being treated. To ensure that the water will be held within the Bioretention Facility on sloped sites, the BMP must be terraced with nonporous check dams to provide the required storage and treatment capacity.

The terraced version of this BMP shall be used on non-flat sites with no more than a 3 percent slope. The surcharge depth cannot exceed 0.5 feet, and side slopes shall not exceed 4:1. Table 2 below shows the spacing of the check dams, and slopes shall be rounded up (i.e., 2.5 percent slope shall use 10' spacing for check dams).

Table 2: Check Dam Spacing

6" Check Dam Spacing	
Slope	Spacing
1%	25'
2%	15'
3%	10'

BIORETENTION FACILITY BMP FACT SHEET

Roof Runoff

Roof downspouts may be directed towards Bioretention Facilities. However, the downspouts must discharge onto a concrete splash block to protect the Bioretention Facility from erosion.

Retaining Walls

It is recommended that Retaining Wall Type 1A, per Caltrans Standard B3-3 or equivalent, be constructed around the entire perimeter of the Bioretention Facility. This practice will protect the sides of the Bioretention Facility from collapsing during construction and maintenance or from high service loads adjacent to the BMP. Where such service loads would not exist adjacent to the BMP, an engineered alternative may be used if signed by a licensed civil engineer.

Side Slope Requirements

Bioretention Facilities Requiring Side Slopes

The design should assure that the Bioretention Facility does not present a tripping hazard. Bioretention Facilities proposed near pedestrian areas, such as areas parallel to parking spaces or along a walkway, must have a gentle slope to the bottom of the facility. Side slopes inside of a Bioretention Facility shall be 4:1. A typical cross section for the Bioretention Facility is shown in Figure 1.

Bioretention Facilities Not Requiring Side Slopes

Where cars park perpendicular to the Bioretention Facility, side slopes are not required. A 6-inch maximum drop may be used, and the Bioretention Facility must be planted with trees and shrubs to prevent pedestrian access. In this case, a curb is not placed around the Bioretention Facility, but wheel stops shall be used to prevent vehicles from entering the Bioretention Facility, as shown in Figure 4.

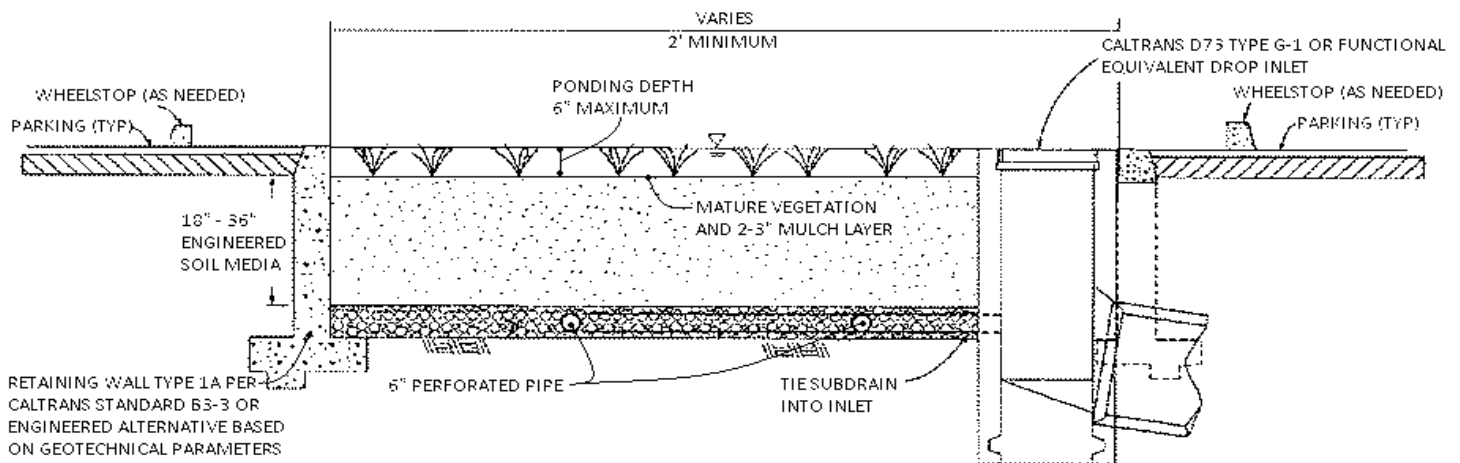

BIORETENTION FACILITY BMP FACT SHEET

Planter Boxes

Bioretention Facilities can also be placed above ground as planter boxes. Planter boxes must have a minimum width of 2 feet, a maximum surcharge depth of 6 inches, and no side slopes are necessary. Planter boxes must be constructed so as to ensure that the top surface of the engineered soil media will remain level. This option may be constructed of concrete, brick, stone or other stable materials that will not warp or bend. Chemically treated wood or galvanized steel, which has the ability to contaminate stormwater, should not be used. Planter boxes must be lined with an impermeable liner on all sides, including the bottom. Due to the impermeable liner, the inside bottom of the planter box shall be designed and constructed with a cross fall, directing treated flows within the subdrain layer toward the point where subdrain exits the planter box, and subdrains shall be oriented with drain holes oriented down. These provisions will help avoid excessive stagnant water within the gravel underdrain layer. Similar to the in-ground Bioretention Facility versions, this BMP benefits from healthy plants and biological activity in the root zone. Planter boxes should be planted with appropriately selected vegetation.



Figure 5: Planter Box

Source: LA Team Effort

Overflow

An overflow route is needed in the Bioretention Facility design to bypass stored runoff from storm events larger than V_{BMP} or in the event of facility or subdrain clogging. Overflow systems must connect to an acceptable discharge point, such as a downstream conveyance system as shown in Figure 1 and Figure 4. The inlet to the overflow structure shall be elevated inside the Bioretention Facility to be flush with the ponding surface for the design capture volume (V_{BMP}) as shown in Figure 4. This will allow the design capture volume to be fully treated by the Bioretention Facility, and for larger events to safely be conveyed to downstream systems. The overflow inlet shall **not** be located in the entrance of a Bioretention Facility, as shown in Figure 6.

BIORETENTION FACILITY BMP FACT SHEET

Underdrain Gravel and Pipes

An underdrain gravel layer and pipes shall be provided in accordance with Appendix B – Underdrains.



Figure 6: Incorrect Placement of an Overflow Inlet.

Inspection and Maintenance Schedule

The Bioretention Facility area shall be inspected for erosion, dead vegetation, soggy soils, or standing water. The use of fertilizers and pesticides on the plants inside the Bioretention Facility should be minimized.

Schedule	Activity
Ongoing	<ul style="list-style-type: none">• Keep adjacent landscape areas maintained. Remove clippings from landscape maintenance activities.• Remove trash and debris• Replace damaged grass and/or plants• Replace surface mulch layer as needed to maintain a 2-3 inch soil cover.
After storm events	<ul style="list-style-type: none">• Inspect areas for ponding
Annually	<ul style="list-style-type: none">• Inspect/clean inlets and outlets

Bioretention Facility Design Procedure

- 1) Enter the area tributary, A_T , to the Bioretention Facility.
- 2) Enter the Design Volume, V_{BMP} , determined from Section 2.1 of this Handbook.
- 3) Select the type of design used. There are two types of Bioretention Facility designs: the standard design used for most project sites that include side slopes, and the modified design used when the BMP is located perpendicular to the parking spaces or with planter boxes that do not use side slopes.
- 4) Enter the depth of the engineered soil media, d_s . The minimum depth for the engineered soil media can be 18' in limited cases, but it is recommended to use 24' or a preferred 36' to provide an adequate root zone for the chosen plant palette. Engineered soil media deeper than 36' will only get credit for the pore space in the first 36'.
- 5) Enter the top width of the Bioretention Facility.
- 6) Calculate the total effective depth, d_E , within the Bioretention Facility. The maximum allowable pore space of the soil media is 30% while the maximum allowable pore space for the gravel layer is 40%. Gravel layer deeper than 12' will only get credit for the pore space in the first 12'.

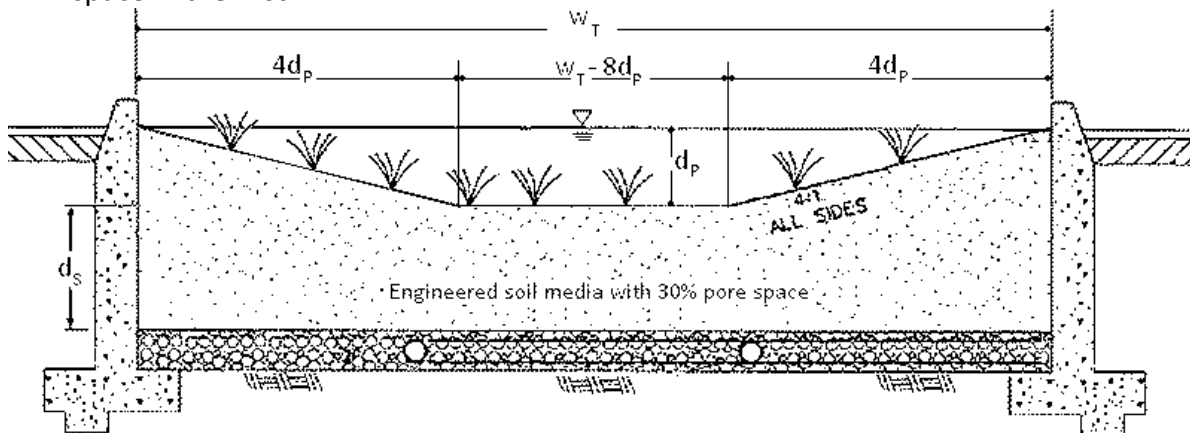

- a. For the design with side slopes the following equation shall be used to determine the total effective depth. Where, d_p is the depth of ponding within the basin.

$$d_E(\text{ft}) = \frac{0.3 \times \left[(w_T(\text{ft}) \times d_s(\text{ft})) + 4(d_p(\text{ft}))^2 \right] + 0.4 \times 1(\text{ft}) + d_p(\text{ft}) \left[4d_p(\text{ft}) + (w_T(\text{ft}) - 8d_p(\text{ft})) \right]}{w_T(\text{ft})}$$

This above equation can be simplified if the maximum ponding depth of 0.5' is used. The equation below is used on the worksheet to find the minimum area required for the Bioretention Facility:

$$d_E(\text{ft}) = (0.3 \times d_s(\text{ft}) + 0.4 \times 1(\text{ft})) - \left(\frac{0.7(\text{ft}^2)}{w_T(\text{ft})} \right) + 0.5(\text{ft})$$

- b. For the design without side slopes the following equation shall be used to determine the total effective depth:

$$d_E(\text{ft}) = d_p(\text{ft}) + [(0.3) \times d_s(\text{ft}) + (0.4) \times 1(\text{ft})]$$

The equation below, using the maximum ponding depth of 0.5', is used on the worksheet to find the minimum area required for the Bioretention Facility:

$$d_E(\text{ft}) = 0.5 (\text{ft}) + [(0.3) \times d_s(\text{ft}) + (0.4) \times 1(\text{ft})]$$

- 7) Calculate the minimum surface area, A_M , required for the Bioretention Facility. This does not include the curb surrounding the Bioretention Facility or side slopes.

$$A_M(\text{ft}^2) = \frac{V_{\text{BMP}}(\text{ft}^3)}{d_E (\text{ft})}$$

- 8) Enter the proposed surface area. This area shall not be less than the minimum required surface area.
- 9) Verify that side slopes are no steeper than 4:1 in the standard design, and are not required in the modified design.
- 10) Provide the diameter, minimum 6 inches, of the perforated underdrain used in the Bioretention Facility. See Appendix B for specific information regarding perforated pipes.
- 11) Provide the slope of the site around the Bioretention Facility, if used. The maximum slope is 3 percent for a standard design.
- 12) Provide the check dam spacing, if the site around the Bioretention Facility is sloped.
- 13) Describe the vegetation used within the Bioretention Facility.

References Used to Develop this Fact Sheet

Anderson, Dale V. "Landscaped Filter Basin Soil Requirements." Riverside, May 2010.

California Department of Transportation. CalTrans Standard Plans. 15 September 2005. May 2010 <http://www.dot.ca.gov/hq/esc/oe/project_plans/HTM/stdplns-met-new99.htm>.

Camp Dresser and McKee Inc.; Larry Walker Associates. California Stormwater Best Management Practice Handbook for New Development and Redevelopment. California Stormwater Quality Association (CASQA), 2004.

Contra Costa Clean Water Program. Stormwater Quality Requirements for Development Applications. 3rd Edition. Contra Costa, 2006.

County of Los Angeles Public Works. Stormwater Best Management Practice Design and Maintenance Manual. Los Angeles, 2009.

Kim, Hunho, Eric A. Seagren and Allen P. Davis. "Engineered Bioretention for Removal of Nitrate from Stormwater Runoff." Water Environment Research 75.4 (2003): 355-366.

LA Team Effort. LA Team Effort: FREE Planter Boxes for Businesses. 2 November 2009. May 2010 <<http://lateameffort.blogspot.com/2009/11/free-planter-boxes-for-businesses-est.html>>.

Montgomery County Maryland Department of Permitting Services Water Resources Section. Biofiltration (BF). Montgomery County, 2005.

Program, Ventura Countywide Stormwater Quality Management. Technical Guidance Manual for Stormwater Quality Control Measures. Ventura, 2002.

United States Environmental Protection Agency. Storm Water Technology Fact Sheet Bioretention. Washington D.C, 1999.

Urban Drainage and Flood Control District. Urban Storm Drainage Criteria Manual Volume 3 - Best Management Practices. Vol. 3. Denver, 2008. 3 vols.

Urbonas, Ben R. Stormwater Sand Filter Sizing and Design: A Unit Operations Approach. Denver: Urban Drainage and Flood Control District, 2002.

Appendix 7: Hydromodification

Supporting Detail Relating to Hydrologic Conditions of Concern

This section will be completed and addressed at the time of the final WQMP submittal.

Appendix 8: Source Control

Pollutant Sources/Source Control Checklist

This section will be completed and addressed at the time of the final WQMP submittal

Appendix 9: O&M

Operation and Maintenance Plan and Documentation of Finance, Maintenance and Recording Mechanisms

This section will be completed and addressed at the time of the final WQMP submittal

Appendix 10: Educational Materials

BMP Fact Sheets, Maintenance Guidelines and Other End-User BMP Information

This section will be completed and addressed at the time of the final WQMP submittal