



**SAGECREST**  
PLANNING + ENVIRONMENTAL

## Highgrove Residential and Commercial Development At Mount Vernon Avenue and Center Street Project

### Appendix J

### Transportation Impact Analysis

October 13, 2020

Mr. Steven Berzansky  
Steven Walker Communities  
7111 Indiana Ave., STE. 300  
Riverside, CA 92504

**Subject: Tentative Tract Map 37743 VMT Evaluation (JN 0342-0001)**

Dear Mr. Berzansky:

Trames Solutions Inc. is pleased to submit this vehicle miles traveled (VMT) evaluation for the proposed TTM 37743 Highgrove development. The project is proposed to be developed with an 8,380 sf retail development, a C-Store with 12 vehicle fueling positions (3,060 sf), and 52 single family residential units. The site is located north of Center Street and east of Mt. Vernon Avenue in the County of Riverside.

The County of Riverside has recently prepared a draft version of their Transportation Analysis Preparation Guide (August 2020) to include a vehicle miles traveled (VMT) analysis methodology. The VMT analysis is based on the passage of SB 743 which replaces automobile delay and LOS as the basis of determining CEQA impacts. Land use projects that have the potential to increase the average VMT per service population (compared to the County's baseline threshold) will be evaluated for potential impacts.

## **PROJECT DESCRIPTION**

The TTM 37743 Highgrove development is proposed to be developed with an 8,380 sf retail development, a C-Store with 12 vehicle fueling positions (3,060 sf), and 52 single family residential units. The site is located north of Center Street and east of Mt. Vernon Avenue in the County of Riverside. Attachment A contains the site plan and anticipated uses.

## **TRIP GENERATION ANALYSIS**

Typically, traffic generated by commercial and residential developments can be determined based on the Institute of Transportation Engineers (ITE), Trip Generation handbook (10<sup>th</sup> edition). This publication contains trip rates based on studies conducted for a variety of uses.

The trip generation due to the land uses are comprised of primary and “pass-by” traffic. Primary traffic refers to trips that are intending to go to the project as their primary destination. Pass-by trips are not new trips but those that are already on the roadway system but are anticipated to “pass-by” the project on their way to a primary destination.

Trip generation rates for the proposed development are shown in Table 1. The ITE Manual indicates that up to 25% of retail trips are comprised of pass-by trips. Similarly, up to 66% of a convenience store’s trips are comprised of pass-by traffic.

The daily and peak hour trip generations for the proposed project are shown on Table 2. The project is estimated to generate a total of approximately 2,160 new trip-ends per day with 137 new vehicle trips per hour during the AM peak hour and 169 new vehicle trips per hour during the PM peak hour.

## **VEHICLE MILES TRAVELED (VMT) EVALUATION**

The intent of the VMT analysis is to reduce Greenhouse Gas (GHG) emissions while promoting the development of infill land use project and multimodal transportation networks, and to promote a diversity of Land uses within developments. The County has developed a six-step process for evaluating land use projects as follows:

- Step 1 - Evaluate land use
- Step 2 – Screen for non-significant transportation impact
- Step 3 – Determine significance threshold and methodology
- Step 4 – Scope of Analysis Agreement
- Step 5 – Analysis and Mitigation
- Step 6 – Mitigation Monitoring (if Required)

### Step 1 – Evaluate land use

The proposed project will consist of 52 single family residential units, a neighborhood retail store, and a C-Store that are intended to serve the local community. High regional traffic to the site is not anticipated based on the type/size of commercial uses and the target customers.

### Step 2 – Screen for non-significant transportation impact

This step is intended to determine if a project would have a non-significant transportation impact. The County has provided seven screening criteria that would allow a project to have a presumed less than significant impact and eliminate the need for further analysis.

- Small Projects
- Projects Near High Quality Transit
- Local-Serving Retail
- Affordable Housing
- Local Essential Service
- Map-Based Screening
- Redevelopment Projects

Criteria 1 and 3 – Small Projects/Local-Serving Retail presumes that low trip generating projects and local serving retail projects will cause a less-than-significant impact if single family residential projects have less than 110 units and a single store on-site does not exceed 50,000 sf. Since the residential project will have 52 units and the retail portion of the proposed project will be 8,380 sf and the C-store will be 3,060 sf, a less than significant impact can be assumed.

## **CONCLUSIONS**

Due to the size of the proposed residential and retail businesses (52 single family units, an 8,380 sf retail store, and a 3,060 sf C-store) serving the nearby community, a less than significant impact from a vehicle miles traveled standpoint can be assumed. Therefore, no further analysis is required.

Mr. Steven Berzansky  
Steven Walker Communities  
October 13, 2020  
Page 4

If you have any questions, please contact me directly at (949) 244-2436.

Respectfully submitted,

Trames Solutions Inc.



Scott Sato, P.E.

Vice President

Attachment A – Site Plan

**TABLE 1  
PROJECT TRIP GENERATION RATES<sup>1</sup>**

Land Use	ITE Code	Quantity <sup>2</sup>	Peak Hour Trip Rates						Daily
			AM			PM			
			IN	OUT	Total	IN	OUT	Total	
Single Fam. Detached	210	52 DU	0.19	0.56	0.75	0.62	0.37	0.99	9.44
Convenience Mkt. w/Pumps	853	12 VFP	10.38	10.38	20.76	11.52	11.52	23.04	322.50
Shopping Center	820	8.38 TSF	0.58	0.36	0.94	1.83	1.98	3.81	37.75

<sup>1</sup> Trip Generation Source: Institute of Transportation Engineers (ITE), Trip Generation Manual, 10th Edition (2017).

<sup>2</sup> VFP = Vehicle Fueling Positions; TSF = Thousand Square Feet; DU = Dwelling Units

**TABLE 2  
PROJECT TRIP GENERATION SUMMARY**

Land Use	Quantity <sup>1</sup>	Peak Hour						Daily	
		AM			PM				
		In	Out	Total	In	Out	Total		
Single Fam. Detached	210	52 DU	10	29	39	32	19	51	491
Convenience Mkt. w/Pumps	853	12 VFP	125	125	250	138	138	276	3,870
- Pass-By Reduction (AM-63%, PM-66%)			-79	-79	-158	-91	-91	-182	-2,438
Shopping Center	820	8.38 TSF	5	3	8	15	17	32	316
- Pass-By Reduction (25%)			-1	-1	-2	-4	-4	-8	-79
<b>TOTAL EXTERNAL TRIPS</b>			<b>60</b>	<b>77</b>	<b>137</b>	<b>90</b>	<b>79</b>	<b>169</b>	<b>2,160</b>

<sup>1</sup> VFP = Vehicle Fueling Positions; TSF = Thousand Square Feet; DU = Dwelling Units

ATTACHMENT A  
SITE PLAN

# SITE PLAN

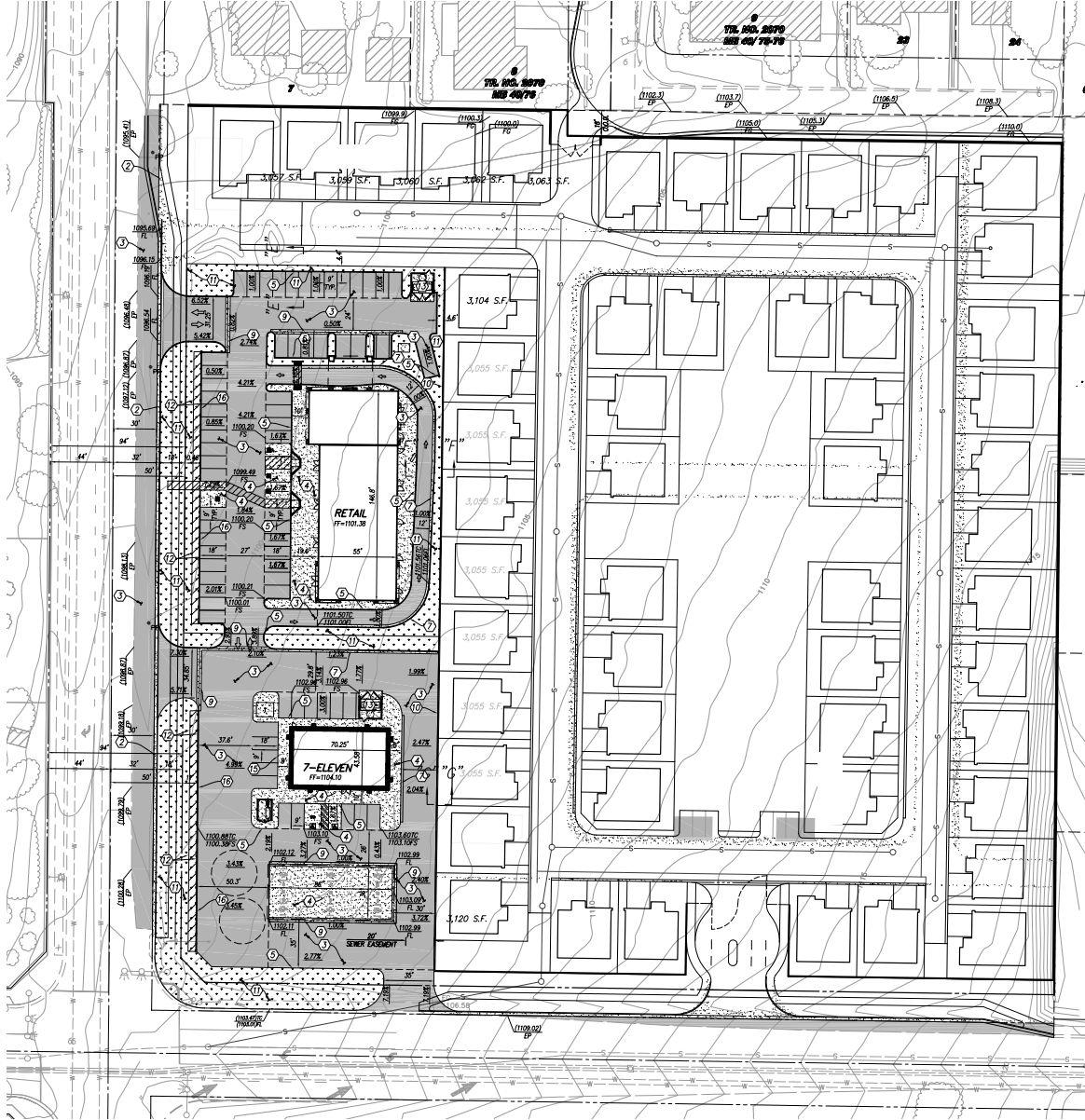

**TTM 37743 - HIGHGROVE  
TRAFFIC IMPACT ANALYSIS  
COUNTY OF RIVERSIDE, CALIFORNIA**

**OCTOBER 30, 2020  
JUNE 4, 2020**

**Prepared for:**

Mr. Steven Berzansky  
Highgrove INV, LLC  
7111 Indiana Ave., STE. 300  
Riverside, CA 92504

---

**Prepared by:**



**Scott Sato, P.E.  
4225 Oceanside Blvd., #354 H  
Oceanside, CA 92056  
(949) 244-2436**

**TRAMES SOLUTIONS INC.**

**(0342-0001-03)**



# TABLE OF CONTENTS

---

<u>SECTION</u>	<u>PAGE</u>
<b>1.0 INTRODUCTION AND SUMMARY .....</b>	<b>1</b>
A. Purpose of the TIA and Study Objectives	
B. Site Location and Study Area	
C. Development Project Identification	
1. Project Size and Description	
2. Existing Land Use	
3. Proposed Land Use	
4. Site Plan of Proposed Project	
5. Proposed Project Opening Year	
6. Proposed Project Phasing	
<b>2.0 TRAFFIC ANALYSIS METHODOLOGIES .....</b>	<b>7</b>
A. Level of Service Definition	
B. County of Riverside Level of Service Criteria	
C. Intersection Operations Analysis Methodology	
<b>3.0 AREA CONDITIONS .....</b>	<b>11</b>
A. Study Area Intersections	
B. Area Roadway System	
C. Existing (2020) Traffic Volumes	
D. Existing (2020) Delay and Level of Service	
E. Transit Service	
<b>4.0 PROJECTED FUTURE TRAFFIC .....</b>	<b>19</b>
A. Project Traffic	
1. Ambient Growth Rate	
2. Project Trip Generation	
3. Project Trip Distribution and Assignment	
4. Project Peak Hour Turning Movement Traffic	
B. Cumulative Traffic (Background)	
1. Method of Projection	
2. Other Approved or Proposed Development Projects	
3. Other Approved Projects Trip Generation	
4. Total Background Peak Hour Turning Movement Volumes	

# TABLE OF CONTENTS (Continued)

---

<u>SECTION</u>	<u>PAGE</u>
<b>5.0 TRAFFIC ANALYSIS .....</b>	<b>37</b>
A. Existing Plus Project (E+P) Conditions	
B. Existing Plus Ambient Plus Project (E+A+P) Conditions (E+A+P 2022) Conditions	
C. Existing Plus Ambient Plus Project Plus Cumulative (E+A+P+C) Conditions	
<b>6.0 FINDINGS AND RECOMMENDATIONS .....</b>	<b>43</b>
A. Traffic Impacts and Level of Service Analysis	
B. Recommended Off-Site Improvements	
C. Circulation Recommendations	
1. On-Site	

# LIST OF FIGURES

---

<u>FIGURE</u>	<u>PAGE</u>
1-A Study Area.....	3
1-B Site Plan .....	5
3-A Existing Traffic Controls and Intersection Geometrics .....	13
3-B Riverside County General Plan Circulation Element and Street Classification Cross-Sections .....	14
3-C City of Grand Terrace General Plan Circulation Map and Street Cross-Sections .....	15
3-D Existing (2020) AM Peak Hour Intersection Volumes.....	16
3-E Existing (2020) PM Peak Hour Intersection Volumes.....	17
4-A Project Trip Distribution.....	22
4-B Project Only and Pass-By AM Peak Hour Intersection Volumes.....	23
4-C Project Only and Pass-By PM Peak Hour Intersection Volumes.....	24
4-D Cumulative Developments Location Map.....	25
4-E Cumulative Developments Only AM Peak Hour Intersection Volumes.....	28
4-F Cumulative Developments Only PM Peak Hour Intersection Volumes.....	29
4-G Existing Plus Project AM Peak Hour Intersection Volumes .....	30
4-H Existing Plus Project PM Peak Hour Intersection Volumes .....	31
4-I Existing Plus Ambient Plus Project AM Peak Hour Intersection Volumes .....	32
4-J Existing Plus Ambient Plus Project PM Peak Hour Intersection Volumes .....	33
4-K Existing Plus Ambient Plus Project Plus Cumulative (2022) AM Peak Hour Intersection Volumes.....	34
4-L Existing Plus Ambient Plus Project Plus Cumulative (2022) PM Peak Hour Intersection Volumes.....	35
6-A Mt. Vernon Avenue / Main Street Conceptual Striping Plan .....	44
6-B On-Site Circulation Recommendations .....	46

# **LIST OF TABLES**

---

<u>TABLE</u>		<u>PAGE</u>
3-1	Intersection Analysis for Existing (2020) Conditions .....	18
4-1	Project Trip Generation Rates .....	21
4-2	Project Trip Generation Summary .....	21
4-3	Cumulative Development Trip Generation Summary .....	27
5-1	Intersection Analysis for Existing Plus Project Conditions .....	38
5-2	Intersection Analysis for Existing Plus Ambient Plus Project (EAP 2022) Conditions ..	40
5-3	Intersection Analysis for Existing Plus Ambient Plus Project Plus Cumulative (EAPC 2022) Conditions .....	41

# **LIST OF APPENDICES**

---

Scoping Agreement .....	A
Traffic Count Worksheets .....	B
Existing (2020) Conditions Intersection Analysis Calculation Worksheets .....	C
Existing Plus Project (E+P) Conditions Intersection Analysis Calculation Worksheets .....	D
Existing Plus Ambient Plus Project (E+A+P 2022) Conditions Intersection Analysis Calculation Worksheets .....	E
Existing Plus Ambient Plus Project Plus Cumulative (E+A+P+C 2022) Conditions Intersection Analysis Calculation Worksheets .....	F

THIS PAGE IS LEFT INTENTIONALLY BLANK

# TTM 37743 HIGHGROVE TRAFFIC IMPACT ANALYSIS

## COUNTY OF RIVERSIDE, CALIFORNIA

### 1.0 INTRODUCTION AND SUMMARY

---

#### A. Purpose of the TIA and Study Objectives

The purpose of this traffic impact analysis (TIA) is to evaluate the traffic impacts of the proposed TTM 37743 Highgrove development. The project is proposed to be developed with an 8,380 sf retail development, a C-Store with 12 vehicle fueling positions, and 52 single family residential units. The site is located north of Center Street and east of Mt. Vernon Avenue in the County of Riverside.

Study objectives include the following:

**Existing (2020) Traffic.** Existing traffic will be counted to determine current conditions. This constitutes the environmental setting for a CEQA analysis at the time that the hearing body reviews the project. Traffic count data shall be new or recent. In some cases, data up to one year old may be acceptable with the approval of the County of Riverside Engineering Department. Any exception to this must be requested prior to approval of the scoping agreement

**Existing (2020) Plus Project Traffic.** Traffic generated by the proposed project will be added to existing traffic counts to identify and analyze impacts on the circulation system.

**Existing + Ambient + Project (EAP 2022).** Traffic conditions prior to the time that the proposed development is completed will be estimated by increasing the existing traffic counts by an appropriate growth rate to be provided by County of Riverside Engineering Department staff, projected to the year that the project is estimated to be completed. Traffic generated by the proposed project will then be added, and the impacts on the circulation system will be analyzed. This will be the basis for determining project-specific impacts, mitigation, and conditions of approval.

**Existing + Ambient + Project + Cumulative (EAPC 2022).** Traffic generated by other approved projects in the study area shall be identified and added to the Project Completion traffic identified in Scenario 3. This may also include projects that are proposed and in the review process, but not yet fully approved. This scenario will be analyzed, and a determination made if improvements funded through an approved funding mechanism (TUMF, DIF, CFD, RBBD etc.) can accommodate the cumulative traffic at the target Level of Service (LOS) identified in the General Plan. If the “funded” improvements can provide the target LOS, payment into the fee program will be considered as cumulative mitigation through the conditions of approval. Other improvements needed beyond the “funded” improvements (such as localized improvements to non-TUMF facilities) should be identified as such.

**B. Site Location and Study Area**

The site is located north of Center Street and east of Mt. Vernon Avenue in the County of Riverside. Figure 1-A illustrates the site location and the traffic analysis study area.

In general, the study area shall include any intersection of Collector or higher classification street with another Collector roadway or higher classification street, at which the proposed project will add 50 or more peak hour trips. Pursuant to the attached scoping agreement (see Appendix “A”), the study area includes the following intersections:

<b>Study Area Intersections</b>	
1.	Mt. Vernon Avenue / Center Street
2.	Michigan Avenue / Center Street
3.	Mt. Vernon Avenue / Main Street
4.	Mt. Vernon Avenue / Spring Street
5.	Mt. Vernon Avenue / Project Driveway 1
6.	Mt. Vernon Avenue / Project Driveway 2
7.	Project Driveway 3 / Center Street
8.	Project Driveway 4 / Center Street

**C. Development Project Identification**

**1. Project Size and Description**

The TTM 37743 Site is proposed to be developed in a single development phase by 2022. The following uses are proposed as indicated below:

- Retail Use (8,380 square feet)
- A convenience store with 12 vehicle fueling positions
- 52 single family residential units

# FIGURE 1-A STUDY AREA

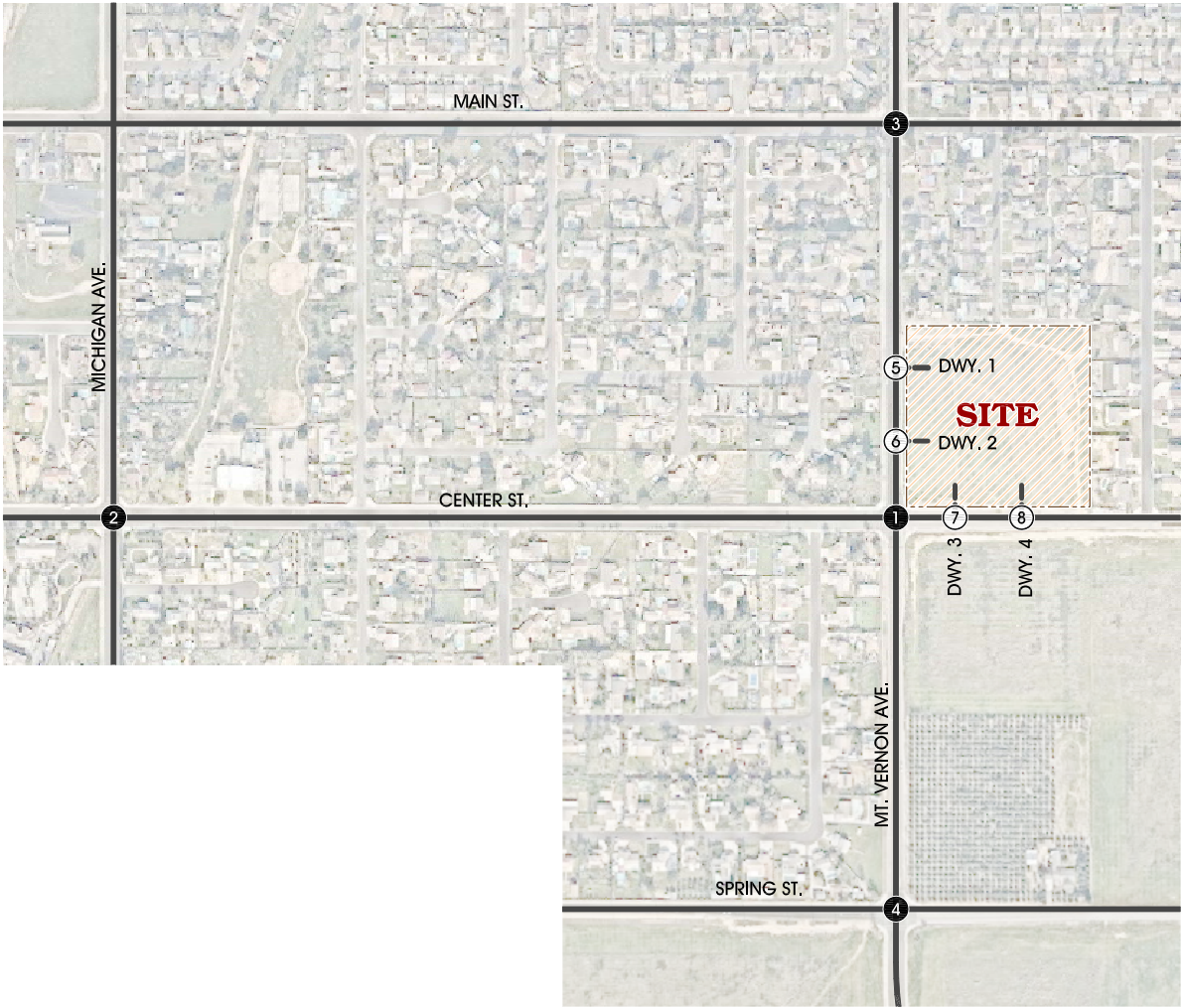

**LEGEND:**

- ④ = EXISTING INTERSECTION ANALYSIS LOCATION
- ④ = FUTURE INTERSECTION ANALYSIS LOCATION
- = FUTURE ROADWAY / PROJECT DRIVEWAY



2. Existing Land Use

The project site is currently vacant. Adjacent uses include the following:

- North – Residential
- South – Vacant
- East – Residential
- West – Residential

3. Proposed Land Use

Proposed Land Use: Parcel A – CR, Parcel B - PDR

4. Site Plan of Proposed Project

Figure 1-B illustrates the conceptual land use plan. As shown in Figure 1-B, the project is proposed to have two commercial driveways (one full access and one right-in/right-out only) along Mt. Vernon Avenue, and one commercial driveway (right-in/right-out only) and one residential driveway (full access) along Center Street.

5. Proposed Project Opening Year

The proposed project is anticipated to be completed by 2022. Future traffic analysis has assumed a background (ambient) growth of 2% per year, along with traffic generated by other future developments in the surrounding area.

6. Proposed Project Phasing

The project is expected to be completed in a single phase. Therefore, all traffic recommendations included in this report have been based on the buildout of the proposed project.

# FIGURE 1-B SITE PLAN

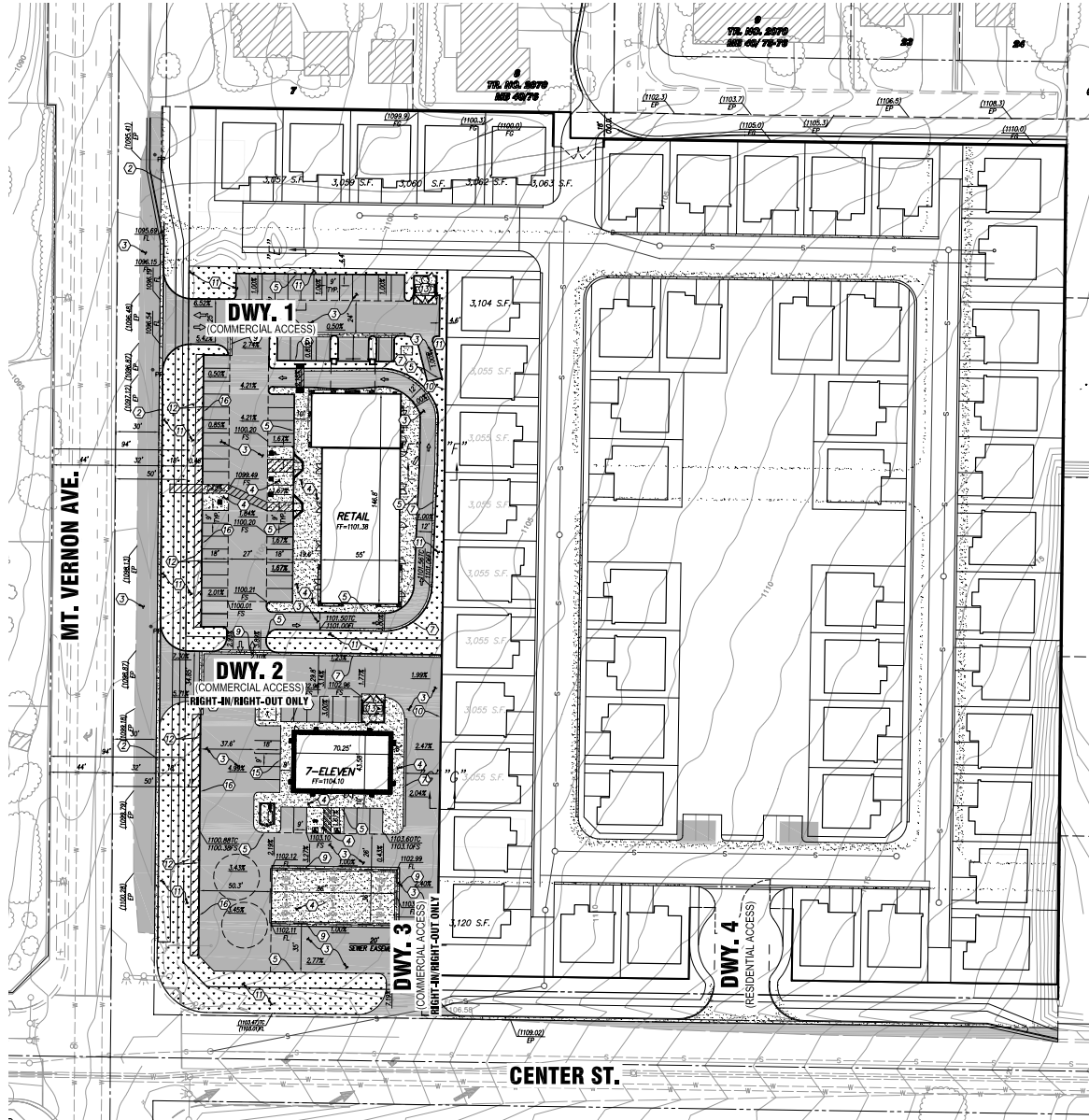

THIS PAGE IS LEFT INTENTIONALLY BLANK

## 2.0 TRAFFIC ANALYSIS METHODOLOGIES

---

Traffic operations are quantified through the determination of "Level of Service" (LOS). Level of Service is a qualitative measure of traffic operating conditions, whereby a letter grade "A" through "F" is assigned to an infrastructure facility (intersection) representing progressively worsening traffic conditions. This section presents the LOS definition, LOS criteria and methodologies for the Intersection Operations.

### A. Level of Service Definition

The definitions of Level of Service for uninterrupted flow (flow unrestrained by the existence of traffic control devices) are:

- LOS "A": Completely free-flow conditions. The operation of vehicles is virtually unaffected by the presence of other vehicles, and operations are constrained only by the geometric features of the highway and by driver preferences. Maneuverability within the traffic stream is good. Minor disruptions to flow are easily absorbed without a change in travel speed.
- LOS "B": Free flow conditions, although the presence of other vehicles becomes noticeable. Average travel speeds are the same as in LOS "A", but drivers have slightly less freedom to maneuver. Minor disruptions are still easily absorbed, although local deterioration in LOS will be more obvious.
- LOS "C": The influence of traffic density on operations becomes marked. The ability to maneuver within the traffic stream is clearly affected by other vehicles. Minor disruptions can cause serious local deterioration in service, and queues will form behind any significant traffic disruption.
- LOS "D": The ability to maneuver is restricted due to traffic congestion. Travel speed is reduced by the increasing volume. Only minor disruptions can be absorbed without extensive queues forming and the service deteriorating.
- LOS "E": Operations at or near capacity, an unstable level. Vehicles are operating with the minimum spacing for maintaining uniform flow.
- LOS "F": Forced or breakdown flow. It occurs either when vehicles arrive at a rate greater than the rate at which they are discharged or when the forecast demand exceeds the computed capacity of a planned facility. Although operations at these points – and on sections immediately downstream – appear to be at capacity, queues form behind these breakdowns. Operations within queues are highly unstable, with vehicles experiencing brief periods of movement followed by stoppages.

## B. County of Riverside Level of Service Criteria

The Riverside County General Plan has established Level of Service (LOS) “C” as the county-wide target along all County maintained roads and conventional state highways. As an exception, LOS “D” may be allowed in Community Development areas, only at intersections of any combination of Secondary Highways, Major Highways, Arterials, Urban Arterials, Expressways, conventional state highways or freeway ramp intersections. For the purposes of this traffic study, LOS “D” has been determined to be the maximum allowable threshold for the intersection operations. Therefore, LOS “E” or “F” is considered unacceptable and requires improvements measures.

## C. Intersection Operations Analysis Methodology

The County of Riverside requires the use of the Transportation Research Board - Highway Capacity Manual (HCM), 6<sup>th</sup> Edition. The HCM defines level of service as a qualitative measure, which describes operational conditions within a traffic stream, generally in terms of such factors as speed and travel time, freedom to maneuver, traffic interruptions, comfort and convenience, and safety. The criteria used to evaluate Level of Service (LOS) conditions vary based on the type of roadway and whether the traffic flow is considered interrupted or uninterrupted. The HCM methodology expresses the level of service at an intersection in terms of delay time for the various intersection approaches. The HCM uses different procedures depending on the type of intersection control.

The level of service is typically dependent on the quality of traffic flow at the intersections along a roadway. The HCM methodology expresses the level of service at an intersection in terms of delay time for the various intersection approaches. The HCM uses different procedures depending on the type of intersection control. The Levels of Service results in this study are determined using the HCM methodology.

For signalized intersections, average total delay per vehicle for the overall intersection is used to determine level of service.

The study area intersections which are stop sign controlled with stop control on the minor street only have been analyzed using the unsignalized intersection methodology of the HCM. For these intersections, the calculation of level of service is dependent on the occurrence of gaps occurring in the traffic flow of the main street. Using data collected describing the intersection configuration and traffic volumes at the study area locations; the level of service has been calculated. The level of service criteria for this type of intersection analysis is based on average total delay per vehicle for the worst minor street movement(s).

For all way stop (AWS) controlled intersections, the ability of vehicles to enter the intersection is not controlled by the occurrence of gaps in the flow of the main street. The AWS controlled intersections have been evaluated using the HCM methodology for this type of multi-way stop controlled intersection configuration. The level of service criteria for this type of intersection analysis is based on average total delay per vehicle.

The levels of service are defined for the various analysis methodologies as follows:

LEVEL OF SERVICE	AVERAGE TOTAL DELAY PER VEHICLE (SECONDS)	
	SIGNALIZED	UNSIGNALIZED
A	0 to 10.00	0 to 10.00
B	10.01 to 20.00	10.01 to 15.00
C	20.01 to 35.00	15.01 to 25.00
D	35.01 to 55.00	25.01 to 35.00
E	55.01 to 80.00	35.01 to 50.00
F	80.01 and up	50.01 and up

Levels of service at the study area intersections have been evaluated using the following HCM intersection analysis program: Synchro.

Peak hour factors (PHF), where known from existing traffic counts, have been used to assess intersection operations.

THIS PAGE IS LEFT INTENTIONALLY BLANK

### 3.0 AREA CONDITIONS

---

A. Study Area Intersections

In general, the minimum area to be studied shall include any intersection of “Collector” or higher classification street, with “Collector” or higher classification streets, at which the proposed project will add 50 or more peak hour. The County of Riverside Engineering Department may require deviation from these requirements based on area conditions. The study area includes the following intersections (shown previously on Figure 1-A):

Study Area Intersections	
1.	Mt. Vernon Avenue / Center Street
2.	Michigan Avenue / Center Street
3.	Mt. Vernon Avenue / Main Street
4.	Mt. Vernon Avenue / Spring Street
5.	Mt. Vernon Avenue / Project Driveway 1
6.	Mt. Vernon Avenue / Project Driveway 2
7.	Project Driveway 3 / Center Street
8.	Project Driveway 4 / Center Street

B. Area Roadway System

Figure 3-A identifies the existing roadway conditions for study area roadways. The existing intersection traffic controls and geometrics are identified.

The County of Riverside Circulation Element and Roadway Cross-Sections are depicted on Figure 3-B. Similarly, the City of Grand Terrace’s Circulation Element and Roadway Cross-Sections are shown on Figure 3-C.

C. Existing (2020) Traffic Volumes

Existing intersection level of service calculations are based upon manual AM and PM peak hour turning movement counts made for Trames Solutions, Inc. in April 2020. Existing (2020) AM and PM peak hour intersection turning movement volumes are shown on Figure 3-D and Figure 3-E, respectively. It should be noted that due to the state mandated stay at home order, schools were not in session during the time that the traffic counts were conducted. Furthermore, it was also observed that traffic volumes in the area were less than normal conditions. Therefore, current traffic counts were collected at three nearby intersections (La Cadena/Barton, Highgrove/Center and La Cadena/Columbia) to compare them with historical data in order to develop an adjustment factor. An adjustment factor of 2.22 and 1.80 has been calculated for the AM and PM peak hour counts, respectively. The data is summarized below:

Intersection	Historical Dates	Historical Counts		Historical Counts plus 2% Ambient Growth		April 2020 Counts		Decreased Volume (Historical Counts with Growth - April 2020 Counts)		Percent Decrease		Adjustment Factor	
		AM	PM	AM	PM	AM	PM	AM	PM	AM	PM	AM	PM
La Cadena / Barton	May 2019	2,043	2,268	2,084	2,313	788	1,156	1,296	1,157	62%	50%		
Highgrove / Center	Feb 2017	917	1,006	972	1,066	504	765	468	301	48%	28%		
La Cadena / Columbia	Feb 2017	2,297	2,824	2,435	2,993	1,185	1,621	1,250	1,372	51%	46%		
<b>Total</b>		<b>5,257</b>	<b>6,098</b>	<b>5,491</b>	<b>6,372</b>	<b>2,477</b>	<b>3,542</b>	<b>3,014</b>	<b>2,830</b>	<b>55%</b>	<b>44%</b>	<b>2.22</b>	<b>1.80</b>

The traffic count worksheets are included in Appendix "B".

D. Existing (2020) Delay and Level of Service

The County of Riverside has established Level of Service (LOS) "D" as the maximum allowable threshold for the intersection operations. Therefore, LOS "E" or "F" is considered unacceptable and requires improvements measures.

The results of the existing conditions intersection analysis are summarized in Table 3-1. The existing condition operations analysis worksheets are provided in Appendix "C". The study intersections are currently operating at an acceptable levels of service (LOS "D" or better) during the peak hours with the existing geometry and traffic controls.

E. Transit Service

The Riverside Transit Agency (RTA) Route 14 currently provides service to the study area.

# FIGURE 3-A EXISTING TRAFFIC CONTROLS AND INTERSECTION GEOMETRICS

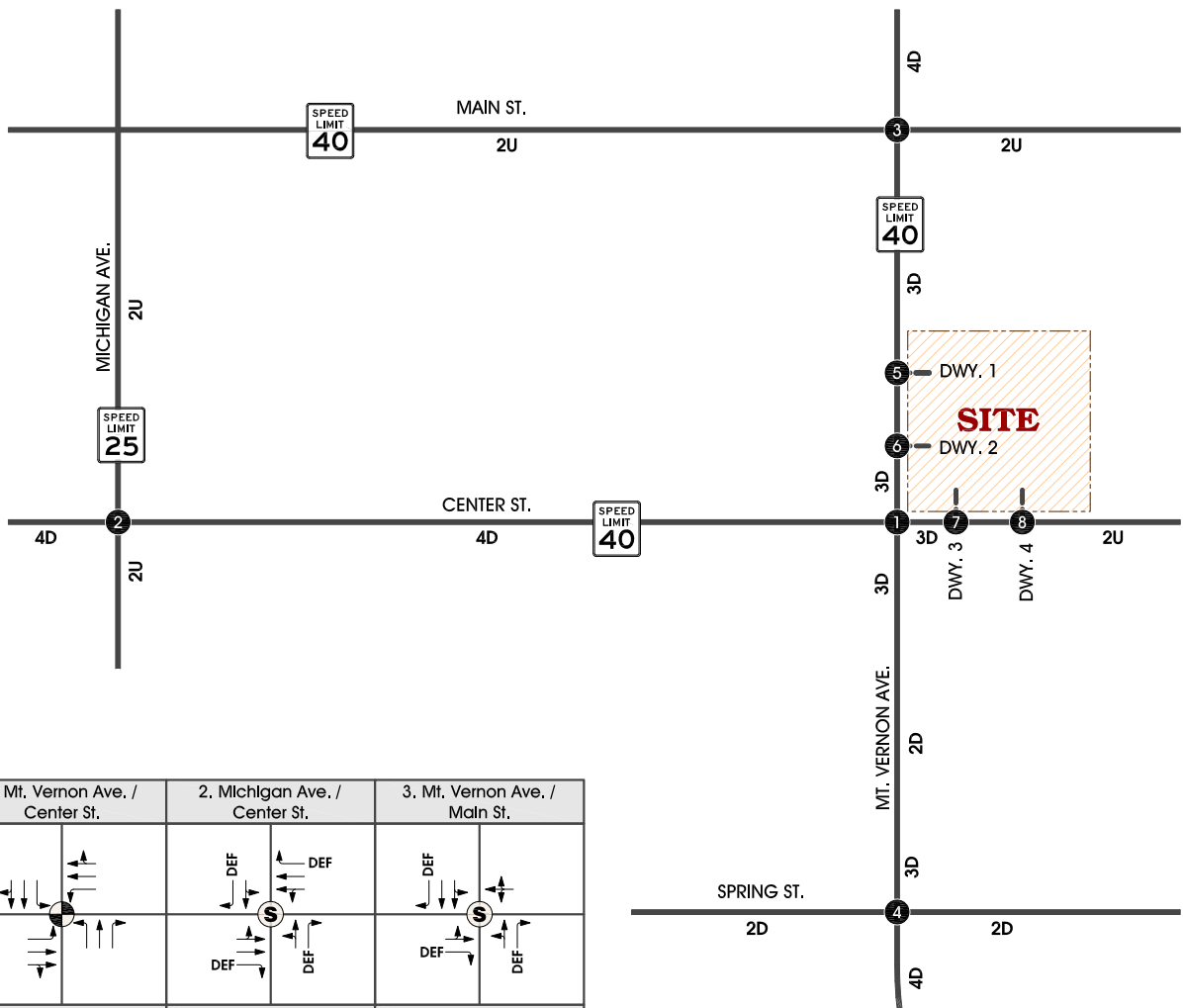

1. Mt. Vernon Ave. / Center St.	2. Michigan Ave. / Center St.	3. Mt. Vernon Ave. / Main St.
4. Mt. Vernon Ave. / Spring St.	5. Mt. Vernon Ave. / Project Dwy. 1	6. Mt. Vernon Ave. / Project Dwy. 2
	FUTURE INTERSECTION	FUTURE INTERSECTION
7. Project Dwy. 3 / Center St.	8. Project Dwy. 4 / Center St.	
FUTURE INTERSECTION	FUTURE INTERSECTION	

**LEGEND:**

- = INTERSECTION ID
- = TRAFFIC SIGNAL
- = ALL WAY STOP
- DEF = DEFACTO RIGHT TURN LANE
- 4 = NUMBER OF LANES
- D = DIVIDED
- U = UNDIVIDED



# FIGURE 3-B RIVERSIDE COUNTY GENERAL PLAN CIRCULATION ELEMENT AND STREET CLASSIFICATION CROSS-SECTIONS

**CIRCULATION ELEMENT MAP**

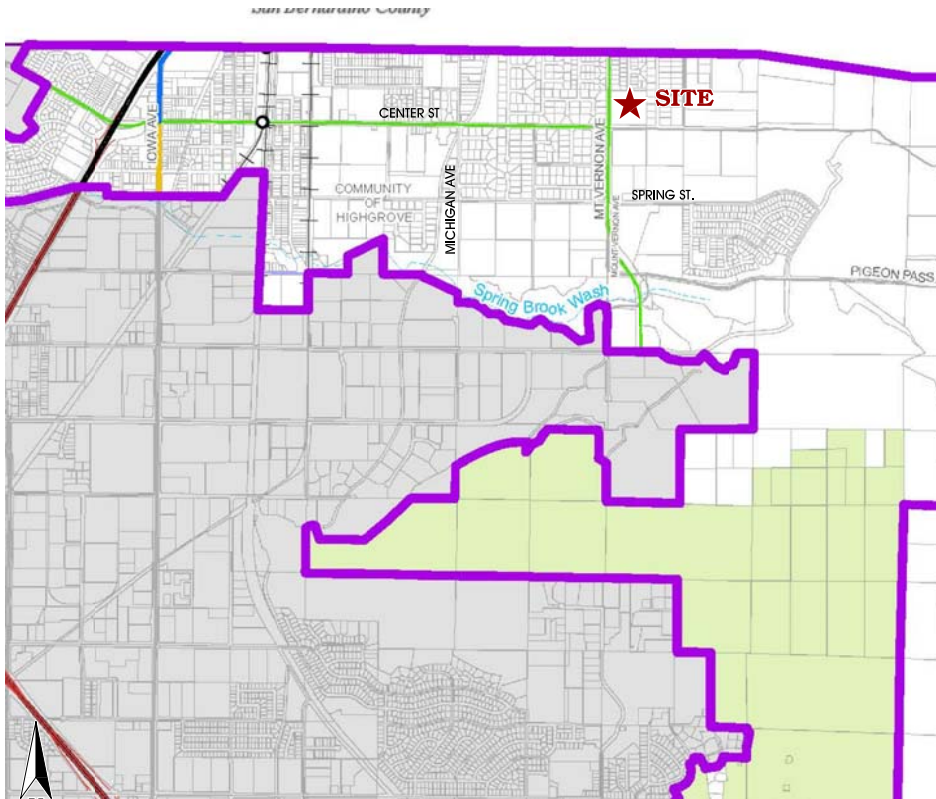

- |                                   |                      |                    |
|-----------------------------------|----------------------|--------------------|
| Freeway (Variable ROW)            | Existing Interchange | Railroads Amended  |
| Expressway (128' to 220' ROW)     | Proposed Interchange | Highways           |
| Urban Arterial (152' ROW)         | Existing Bridge      | Area Plan Boundary |
| Arterial (128' ROW)               | Proposed Bridge      | City Boundary      |
| Major (118' ROW)                  | Waterbodies          |                    |
| Secondary (100' ROW)              |                      |                    |
| Mountain Arterial 2 Ln (110' ROW) |                      |                    |
| Collector (74' ROW)               |                      |                    |

**STREET CLASSIFICATION CROSS-SECTIONS**

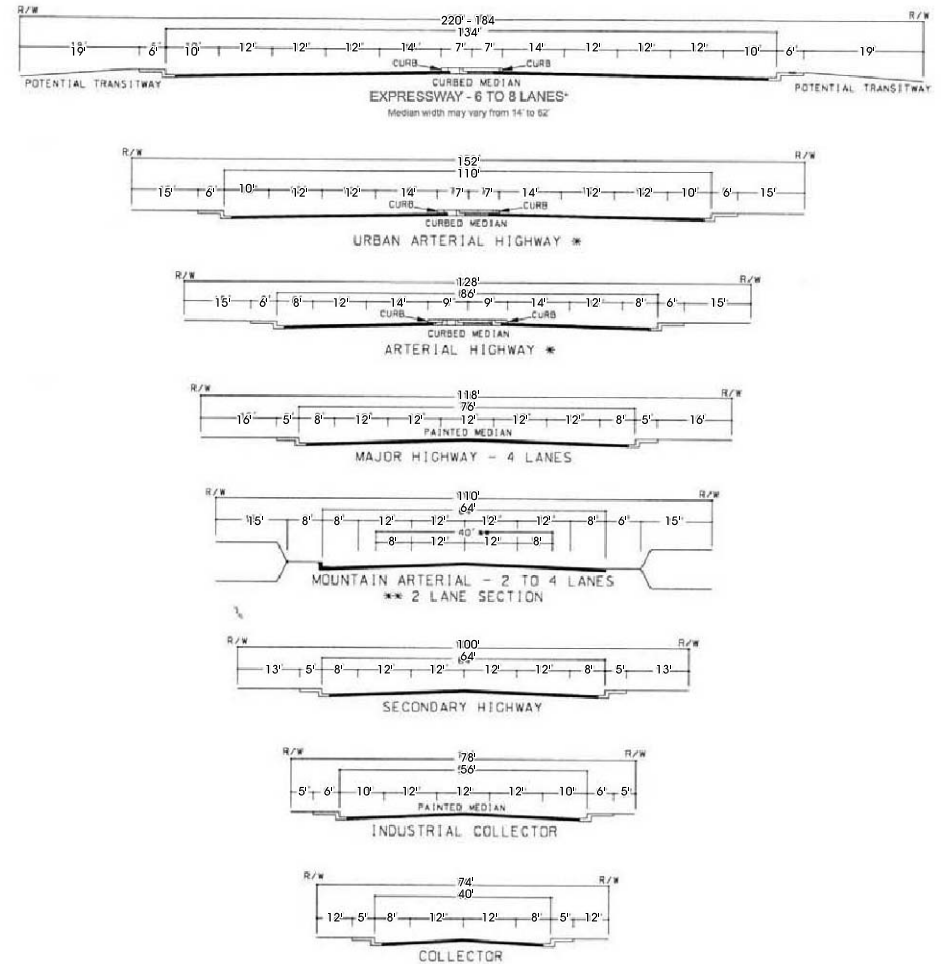

\*IMPROVEMENTS MAY BE RECONFIGURED TO ACCOMMODATE EXCLUSIVE TRANSIT LANES OR ALTERNATIVE LANE ARRANGEMENTS. ADDITIONAL RIGHT OF WAY MAY BE REQUIRED AT INTERSECTIONS TO ACCOMMODATE. ULTIMATE IMPROVEMENTS FOR STATE HIGHWAYS SHALL CONFORM TO CALTRANS DESIGN STANDARDS.

SOURCE: RIVERSIDE COUNTY GENERAL PLAN (2015 UPDATE)

# FIGURE 3-C CITY OF GRAND TERRACE GENERAL PLAN CIRCULATION MAP AND STREET CROSS-SECTIONS

## CIRCULATION MAP

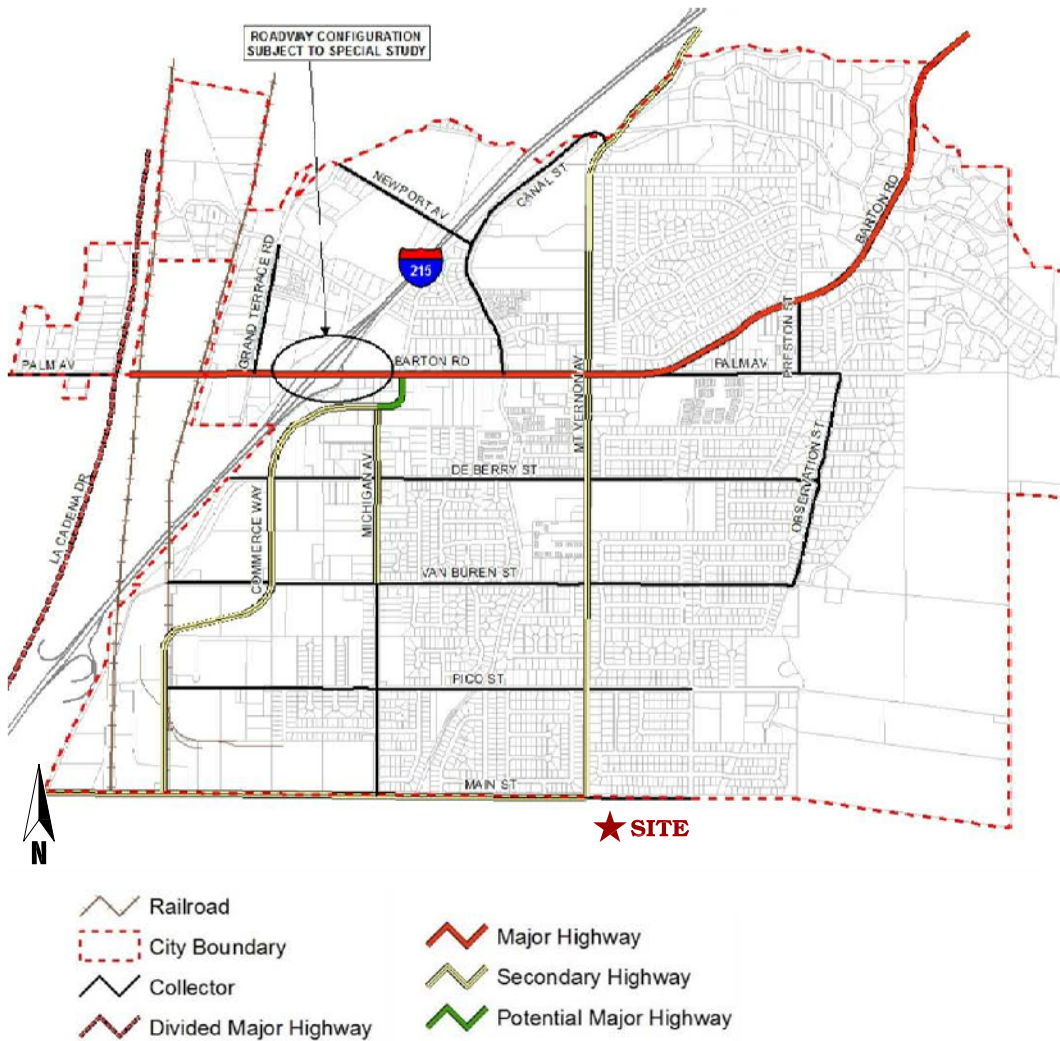

## STREET CROSS-SECTIONS

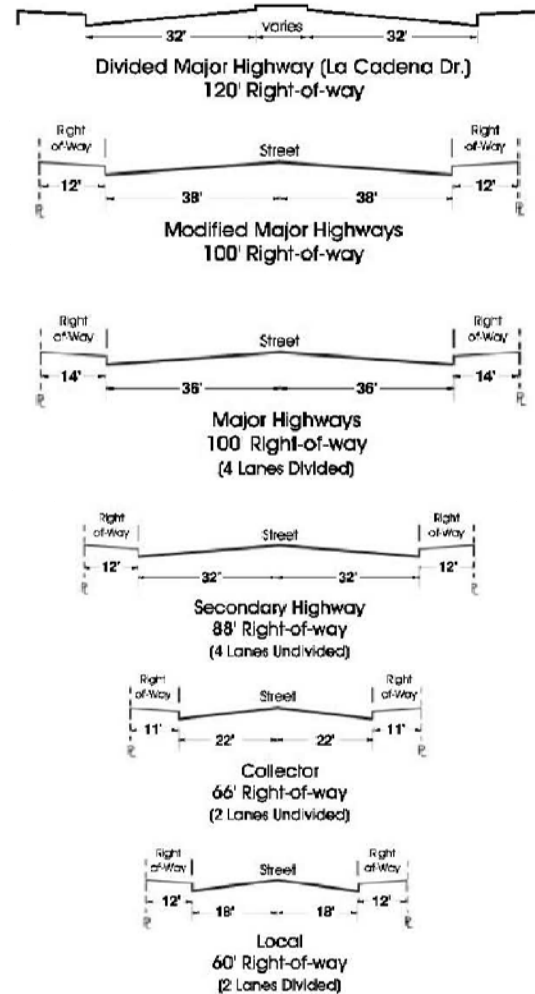

Note: Cross-sections may be modified to accommodate additional turning lanes with the designated right-of-way.

SOURCE: CITY OF GRAND TERRACE GENERAL PLAN (ADOPTED 2010)

# FIGURE 3-D EXISTING (2020) AM PEAK HOUR INTERSECTION VOLUMES

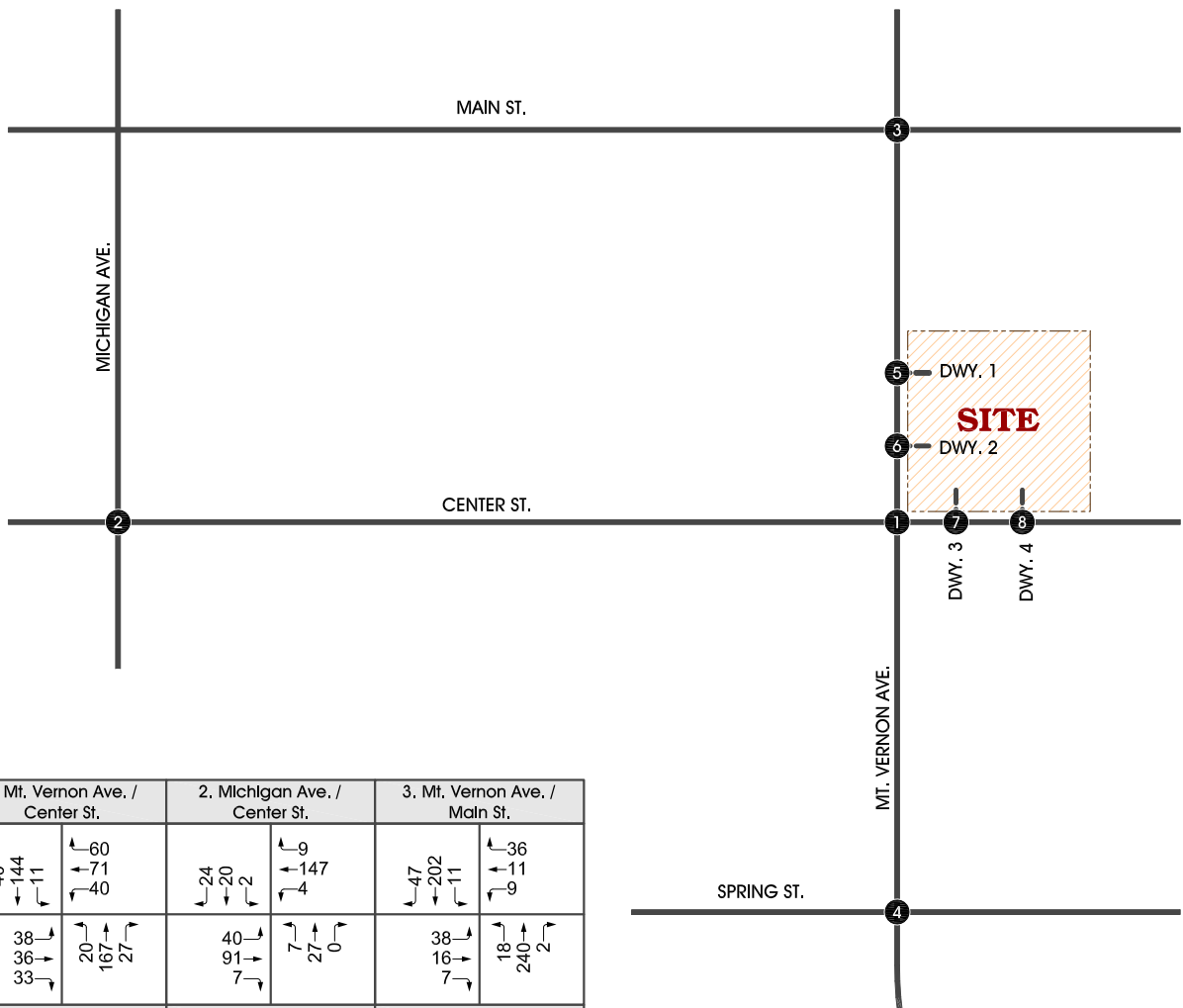

1. Mt. Vernon Ave. / Center St.	2. Michigan Ave. / Center St.	3. Mt. Vernon Ave. / Main St.																																																
<table style="width: 100%; border-collapse: collapse;"> <tr> <td style="text-align: center;">40 ←</td> <td style="text-align: center;">144 ←</td> <td style="text-align: center;">11 ←</td> <td style="text-align: center;">60 ←</td> <td style="text-align: center;">71 ←</td> <td style="text-align: center;">40 ←</td> </tr> <tr> <td style="text-align: center;">38 →</td> <td style="text-align: center;">20 →</td> <td style="text-align: center;">167 →</td> <td style="text-align: center;">24 →</td> <td style="text-align: center;">20 →</td> <td style="text-align: center;">2 →</td> </tr> <tr> <td style="text-align: center;">36 →</td> <td style="text-align: center;">27 →</td> <td style="text-align: center;">7 →</td> <td style="text-align: center;">9 →</td> <td style="text-align: center;">147 →</td> <td style="text-align: center;">4 →</td> </tr> <tr> <td style="text-align: center;">33 →</td> <td style="text-align: center;">7 →</td> <td style="text-align: center;">0 →</td> <td style="text-align: center;">47 →</td> <td style="text-align: center;">202 →</td> <td style="text-align: center;">11 →</td> </tr> </table>	40 ←	144 ←	11 ←	60 ←	71 ←	40 ←	38 →	20 →	167 →	24 →	20 →	2 →	36 →	27 →	7 →	9 →	147 →	4 →	33 →	7 →	0 →	47 →	202 →	11 →	<table style="width: 100%; border-collapse: collapse;"> <tr> <td style="text-align: center;">60 ←</td> <td style="text-align: center;">71 ←</td> <td style="text-align: center;">40 ←</td> </tr> <tr> <td style="text-align: center;">24 →</td> <td style="text-align: center;">20 →</td> <td style="text-align: center;">2 →</td> </tr> <tr> <td style="text-align: center;">9 →</td> <td style="text-align: center;">147 →</td> <td style="text-align: center;">4 →</td> </tr> <tr> <td style="text-align: center;">47 →</td> <td style="text-align: center;">202 →</td> <td style="text-align: center;">11 →</td> </tr> </table>	60 ←	71 ←	40 ←	24 →	20 →	2 →	9 →	147 →	4 →	47 →	202 →	11 →	<table style="width: 100%; border-collapse: collapse;"> <tr> <td style="text-align: center;">36 ←</td> <td style="text-align: center;">11 ←</td> <td style="text-align: center;">9 ←</td> </tr> <tr> <td style="text-align: center;">38 →</td> <td style="text-align: center;">18 →</td> <td style="text-align: center;">240 →</td> </tr> <tr> <td style="text-align: center;">16 →</td> <td style="text-align: center;">2 →</td> <td style="text-align: center;">7 →</td> </tr> <tr> <td style="text-align: center;">7 →</td> <td style="text-align: center;">18 →</td> <td style="text-align: center;">11 →</td> </tr> </table>	36 ←	11 ←	9 ←	38 →	18 →	240 →	16 →	2 →	7 →	7 →	18 →	11 →
40 ←	144 ←	11 ←	60 ←	71 ←	40 ←																																													
38 →	20 →	167 →	24 →	20 →	2 →																																													
36 →	27 →	7 →	9 →	147 →	4 →																																													
33 →	7 →	0 →	47 →	202 →	11 →																																													
60 ←	71 ←	40 ←																																																
24 →	20 →	2 →																																																
9 →	147 →	4 →																																																
47 →	202 →	11 →																																																
36 ←	11 ←	9 ←																																																
38 →	18 →	240 →																																																
16 →	2 →	7 →																																																
7 →	18 →	11 →																																																
4. Mt. Vernon Ave. / Spring St.	5. Mt. Vernon Ave. / Project Dwy. 1	6. Mt. Vernon Ave. / Project Dwy. 2																																																
<table style="width: 100%; border-collapse: collapse;"> <tr> <td style="text-align: center;">16 ←</td> <td style="text-align: center;">164 ←</td> <td style="text-align: center;">27 ←</td> <td style="text-align: center;">91 ←</td> <td style="text-align: center;">22 ←</td> <td style="text-align: center;">22 ←</td> </tr> <tr> <td style="text-align: center;">9 →</td> <td style="text-align: center;">7 →</td> <td style="text-align: center;">135 →</td> <td style="text-align: center;">7 →</td> <td style="text-align: center;">9 →</td> <td style="text-align: center;">9 →</td> </tr> </table>	16 ←	164 ←	27 ←	91 ←	22 ←	22 ←	9 →	7 →	135 →	7 →	9 →	9 →	FUTURE INTERSECTION	FUTURE INTERSECTION																																				
16 ←	164 ←	27 ←	91 ←	22 ←	22 ←																																													
9 →	7 →	135 →	7 →	9 →	9 →																																													
7. Project Dwy. 3 / Center St.	8. Project Dwy. 4 / Center St.																																																	
FUTURE INTERSECTION	FUTURE INTERSECTION																																																	

**LEGEND:**

⑧ = INTERSECTION ID



# FIGURE 3-E EXISTING (2020) PM PEAK HOUR INTERSECTION VOLUMES

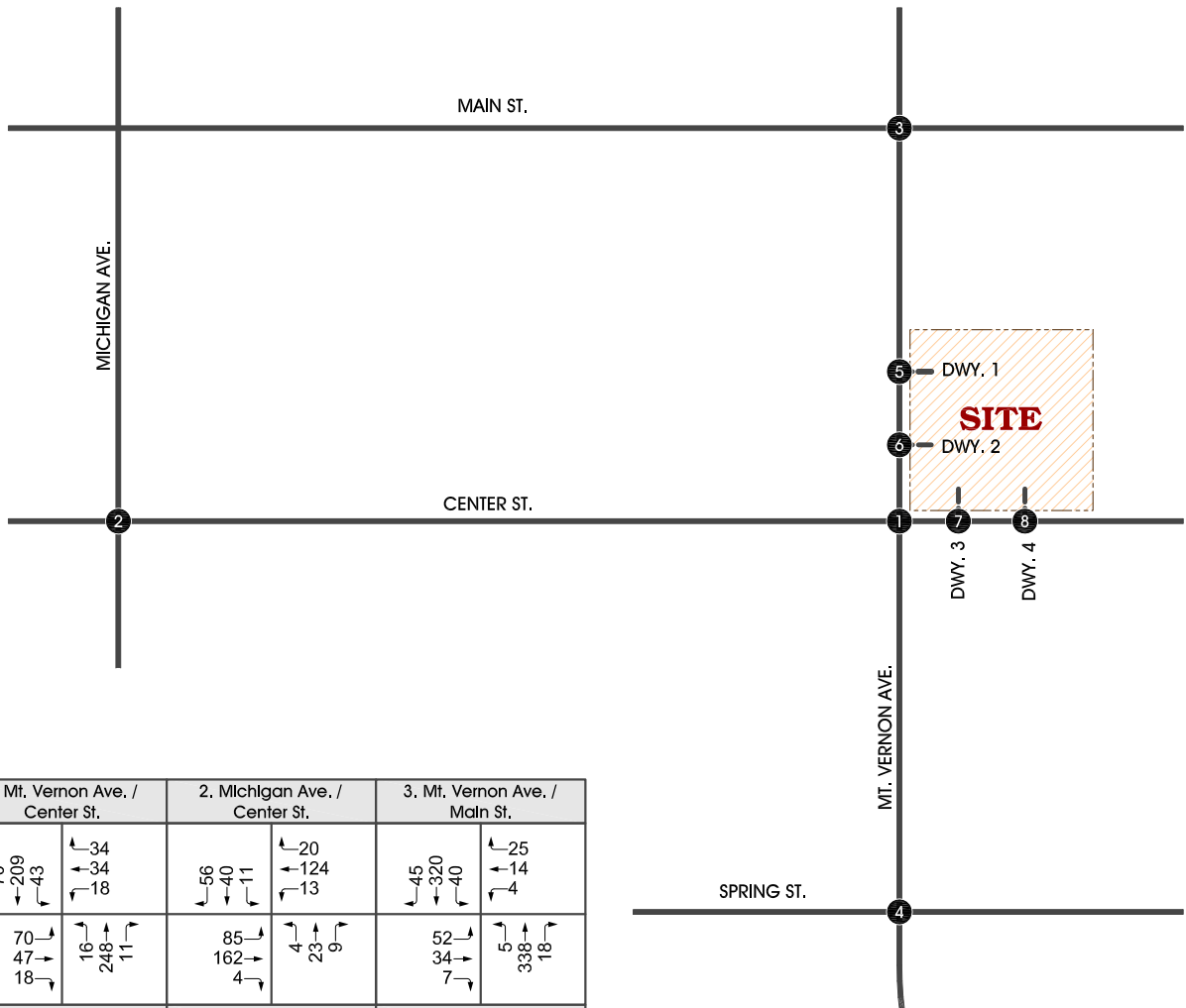

1. Mt. Vernon Ave. / Center St.	2. Michigan Ave. / Center St.	3. Mt. Vernon Ave. / Main St.																																				
<table border="1"> <tr> <td>70</td> <td>209</td> <td>43</td> <td>34</td> </tr> <tr> <td>47</td> <td>16</td> <td>248</td> <td>11</td> </tr> <tr> <td>18</td> <td>11</td> <td>34</td> <td>18</td> </tr> </table>	70	209	43	34	47	16	248	11	18	11	34	18	<table border="1"> <tr> <td>56</td> <td>40</td> <td>11</td> <td>20</td> </tr> <tr> <td>85</td> <td>4</td> <td>23</td> <td>9</td> </tr> <tr> <td>162</td> <td>4</td> <td>124</td> <td>13</td> </tr> </table>	56	40	11	20	85	4	23	9	162	4	124	13	<table border="1"> <tr> <td>45</td> <td>320</td> <td>40</td> <td>25</td> </tr> <tr> <td>52</td> <td>5</td> <td>338</td> <td>18</td> </tr> <tr> <td>34</td> <td>7</td> <td>14</td> <td>4</td> </tr> </table>	45	320	40	25	52	5	338	18	34	7	14	4
70	209	43	34																																			
47	16	248	11																																			
18	11	34	18																																			
56	40	11	20																																			
85	4	23	9																																			
162	4	124	13																																			
45	320	40	25																																			
52	5	338	18																																			
34	7	14	4																																			
4. Mt. Vernon Ave. / Spring St.	5. Mt. Vernon Ave. / Project Dwy. 1	6. Mt. Vernon Ave. / Project Dwy. 2																																				
<table border="1"> <tr> <td>4</td> <td>160</td> <td>85</td> <td>58</td> </tr> <tr> <td>9</td> <td>11</td> <td>218</td> <td>32</td> </tr> <tr> <td>20</td> <td>5</td> <td>14</td> <td>25</td> </tr> </table>	4	160	85	58	9	11	218	32	20	5	14	25	FUTURE INTERSECTION	FUTURE INTERSECTION																								
4	160	85	58																																			
9	11	218	32																																			
20	5	14	25																																			
7. Project Dwy. 3 / Center St.	8. Project Dwy. 4 / Center St.																																					
FUTURE INTERSECTION	FUTURE INTERSECTION																																					

**LEGEND:**

⑧ = INTERSECTION ID



**TABLE 3-1  
INTERSECTION ANALYSIS FOR EXISTING (2020) CONDITIONS**

ID	Intersection	Traffic Control <sup>1</sup>	Intersection Approach Lanes <sup>2</sup>												Delay <sup>3</sup> (secs.)		Level of Service <sup>3</sup>	
			Northbound			Southbound			Eastbound			Westbound			AM	PM	AM	PM
			L	T	R	L	T	R	L	T	R	L	T	R				
1	Mt. Vernon Ave. / Center St.	TS	1	1	1	1	2	0	1	2	0	1	2	0	18.3	17.2	B	B
2	Michigan Ave. / Center St.	AWS	0.5	0.5	d	0.5	0.5	d	0.5	1.5	d	0.5	1.5	d	8.6	9.2	A	A
3	Mt. Vernon Ave. / Main St.	AWS	0.5	0.5	d	0.5	1.5	d	0.5	0.5	d	0	1!	0	11.2	16.8	B	C
4	Mt. Vernon Ave. / Spring St.	TS	1	2	0	1	1	1	1	1	0	1	1	0	15.7	18.3	B	B
5	Mt. Vernon Ave. / Project Dwy. 1	-	Future Intersection												-	-	-	-
6	Mt. Vernon Ave. / Project Dwy. 2	-	Future Intersection												-	-	-	-
7	Project Dwy. 3 / Center St.	-	Future Intersection												-	-	-	-
8	Project Dwy. 4 / Center St.	-	Future Intersection												-	-	-	-

<sup>1</sup> TS = Traffic Signal; AWS = All Way Stop

<sup>2</sup> When a right turn is designated, the lane can either be striped or unstriped. To function as a right turn lane there must be sufficient width for right turning vehicles to travel outside the through lanes.

L = Left; T = Through; R = Right; 1! = Shared Left-Through-Right Lane; 0.5 = Shared Lane; d = Defacto right turn lane

<sup>3</sup> Delay and level of service calculated using the following analysis software: Synchro 10 HCM6

## 4.0 PROJECTED FUTURE TRAFFIC

---

This section of the report quantifies the number of trips generated by the proposed project and other known developments in the area.

### A. Project Traffic

#### 1. Ambient Growth Rate

Some traffic volume increases on roadways can be attributed to vehicles originating outside of the study area. These types of trips either end up within the study area or pass-through onto an outside destination. Therefore, to account for these trips (termed “ambient growth”), a growth rate can be applied to existing traffic volumes.

A 2% ambient growth rate per year has been used in this study to account for traffic not attributed to the project or other planned developments within the study area. The County of Riverside Transportation Department staff has previously reviewed and approved this rate.

#### 2. Project Trip Generation

Trip generation represents the amount of traffic which is attracted and produced by a development. The trip generation for the project is based upon the specific land use which has been planned for this development. For the purpose of this analysis, the following land use assumption is evaluated:

- Retail Use (8,380 square feet)
- A convenience store with 12 vehicle fueling positions
- 52 single family residential units

Trip generation rates for the proposed development are shown in Table 4-1. The trip generation rates are based upon data collected by the Institute of Transportation Engineers (ITE).

The land uses are comprised of primary and “pass-by” traffic. Primary traffic refers to trips that are intending to go to the project as their primary destination. Pass-by trips are not new trips but those that are already on the roadway system but are anticipated to “pass-by” the project on their way to a primary destination.

The ITE Manual indicates that up to 25% of retail trips are comprised of pass-by trips. Similarly, up to 66% of a convenience store's trips are comprised of pass-by traffic.

The daily and peak hour trip generations for the proposed project are shown on Table 4-2. The project is estimated to generate a total of approximately 2,160 new trip-ends per day with 137 new vehicle trips per hour during the AM peak hour and 169 new vehicle trips per hour during the PM peak hour.

### 3. Project Trip Distribution and Assignment

Trip distribution represents the directional orientation of traffic to and from the project site. The project's trip distribution patterns are based on the proximity of the residential units to the proposed driveway locations, the surrounding trip attractors (residential communities, commercial opportunities, etc.), and the regional freeway interchanges. The trip distribution pattern for the project is illustrated on Figure 4-A.

### 4. Project Peak Hour Turning Movement Traffic

The assignment of traffic from the site to the adjoining roadway system has been based upon the site's trip generation, trip distribution, proposed arterial highway and local street systems, which would be in place by the time of initial occupancy of the site. Based on the identified project traffic generation and distribution, Project AM and PM peak hour intersection traffic volumes are shown on Figures 4-B and 4-C, respectively.

## B. Cumulative Traffic (Background)

### 1. Method of Projection

To assess existing plus ambient plus cumulative plus project traffic conditions, project traffic is combined with existing traffic, area-wide growth and other future developments which are approved or being processed concurrently in the study area. Developments which are being processed concurrently in the study area have been provided by the County of Riverside staff.

### 2. Other Approved or Proposed Development Projects

The cumulative developments have been included along with the land use associated with each project. The location of the cumulative projects provided by the County are shown on Figure 4-D.

**TABLE 4-1  
PROJECT TRIP GENERATION RATES<sup>1</sup>**

Land Use	ITE Code	Quantity <sup>2</sup>	Peak Hour Trip Rates						Daily
			AM			PM			
			IN	OUT	Total	IN	OUT	Total	
Single Fam. Detached	210	52 DU	0.19	0.56	0.75	0.62	0.37	0.99	9.44
Convenience Mkt. w/Pumps	853	12 VFP	10.38	10.38	20.76	11.52	11.52	23.04	322.50
Shopping Center	820	8.38 TSF	0.58	0.36	0.94	1.83	1.98	3.81	37.75

<sup>1</sup> Trip Generation Source: Institute of Transportation Engineers (ITE), Trip Generation Manual, 10th Edition (2017).

<sup>2</sup> VFP = Vehicle Fueling Positions; TSF = Thousand Square Feet; DU = Dwelling Units

**TABLE 4-2  
PROJECT TRIP GENERATION SUMMARY**

Land Use	Quantity <sup>1</sup>	Peak Hour						Daily	
		AM			PM				
		In	Out	Total	In	Out	Total		
Single Fam. Detached	210	52 DU	10	29	39	32	19	51	491
Convenience Mkt. w/Pumps	853	12 VFP	125	125	250	138	138	276	3,870
- Pass-By Reduction (AM-63%, PM-66%)			-79	-79	-158	-91	-91	-182	-2,438
Shopping Center	820	8.38 TSF	5	3	8	15	17	32	316
- Pass-By Reduction (25%)			-1	-1	-2	-4	-4	-8	-79
<b>TOTAL EXTERNAL TRIPS</b>			<b>60</b>	<b>77</b>	<b>137</b>	<b>90</b>	<b>79</b>	<b>169</b>	<b>2,160</b>

<sup>1</sup> VFP = Vehicle Fueling Positions; TSF = Thousand Square Feet; DU = Dwelling Units

# FIGURE 4-A PROJECT TRIP DISTRIBUTION

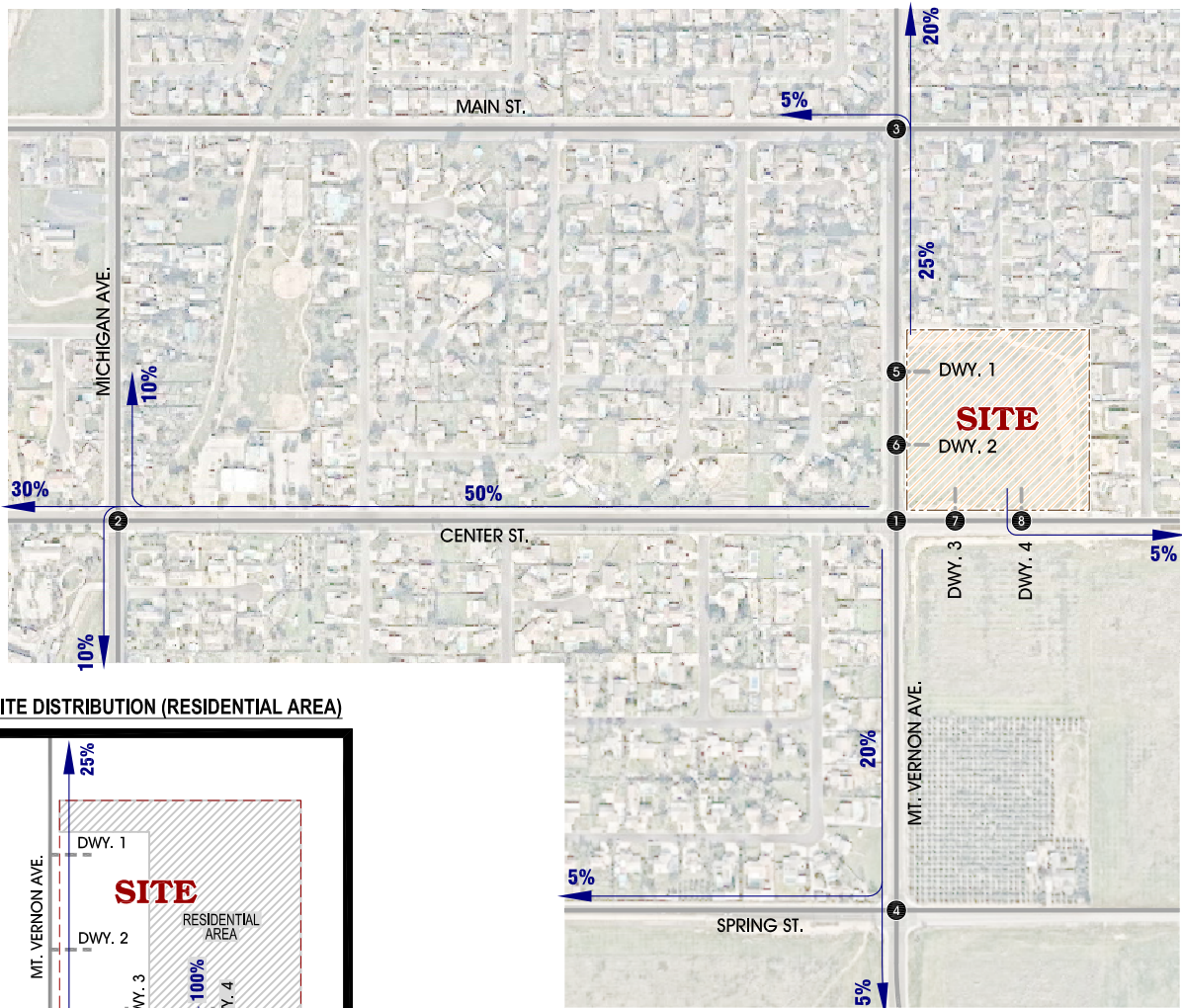

**ON-SITE DISTRIBUTION (RESIDENTIAL AREA)**

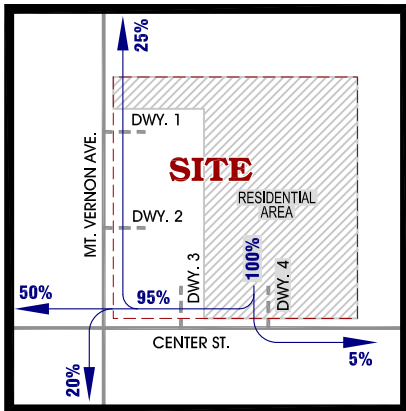

**ON-SITE DISTRIBUTION (COMMERCIAL AREA)**

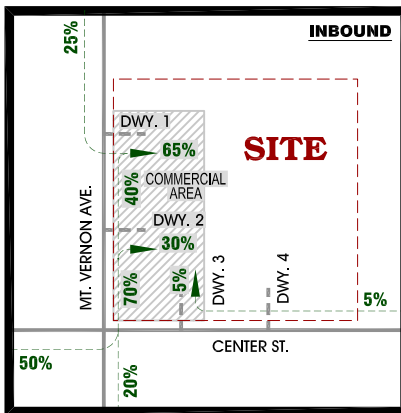
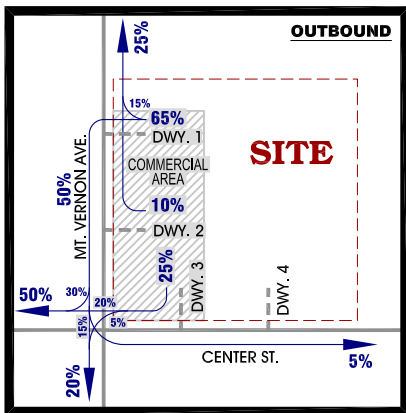

**LEGEND:**

- 8 = INTERSECTION ID
- 10%** = PERCENT TO / FROM PROJECT
- 10%** = PERCENT TO PROJECT (FOR COMMERCIAL SITE AREA)



# FIGURE 4-B PROJECT & PASS-BY AM PEAK HOUR INTERSECTION VOLUMES

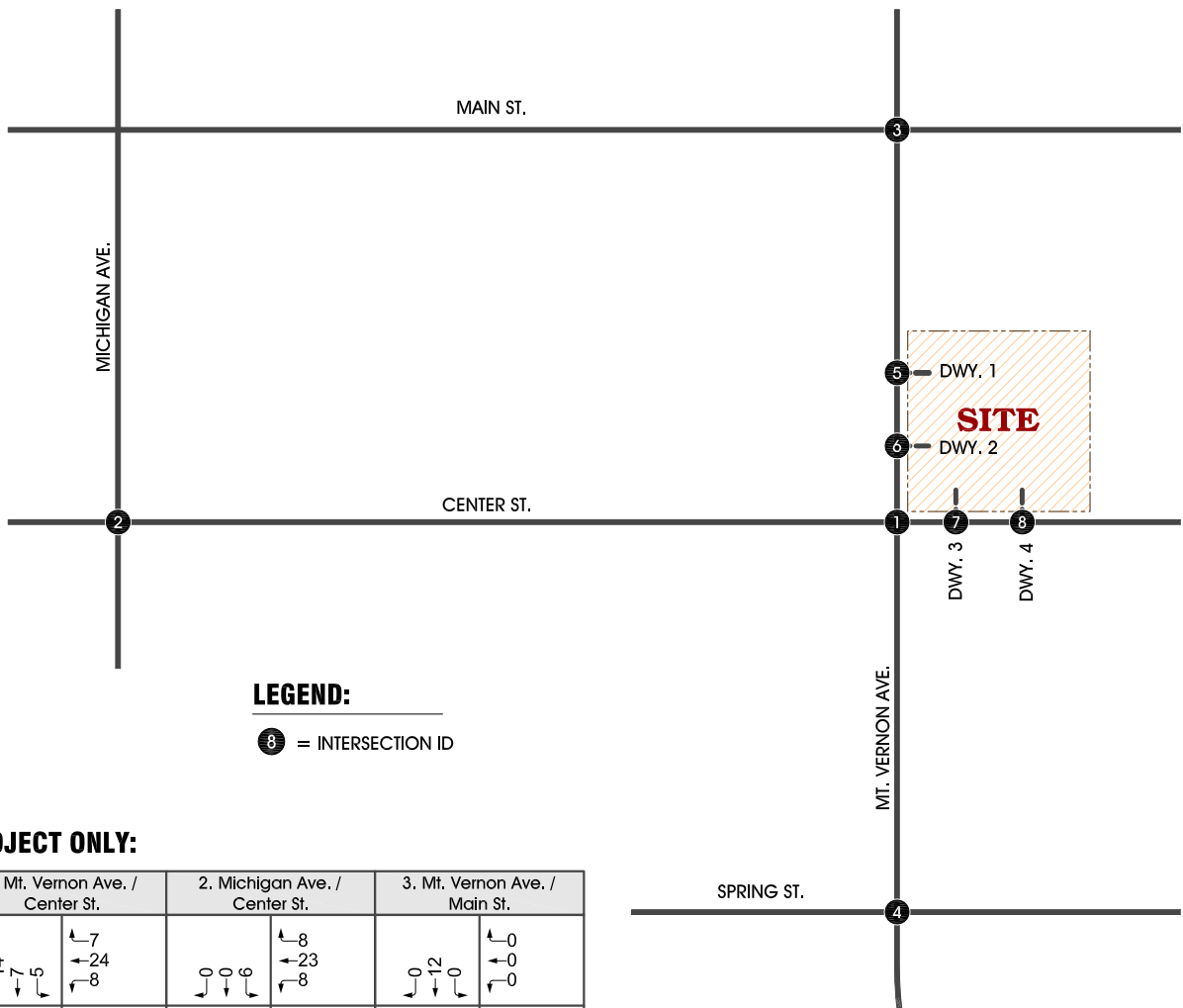

**PROJECT ONLY:**

1. Mt. Vernon Ave. / Center St.	2. Michigan Ave. / Center St.	3. Mt. Vernon Ave. / Main St.																																				
<table style="width: 100%; border-collapse: collapse;"> <tr> <td style="width: 50%; border-right: 1px solid black;"> <table style="width: 100%; border-collapse: collapse;"> <tr><td style="width: 50%;">←14</td><td style="width: 50%;">←7</td></tr> <tr><td style="width: 50%;">←7</td><td style="width: 50%;">←24</td></tr> <tr><td style="width: 50%;">←5</td><td style="width: 50%;">←8</td></tr> </table> </td> <td style="width: 50%;"> <table style="width: 100%; border-collapse: collapse;"> <tr><td style="width: 50%;">←8</td><td style="width: 50%;">←23</td></tr> <tr><td style="width: 50%;">←8</td><td style="width: 50%;">←8</td></tr> </table> </td> </tr> <tr> <td style="border-right: 1px solid black;"> <table style="width: 100%; border-collapse: collapse;"> <tr><td style="width: 50%;">25</td><td style="width: 50%;">0</td></tr> <tr><td style="width: 50%;">5</td><td style="width: 50%;">10</td></tr> <tr><td style="width: 50%;">0</td><td style="width: 50%;">2</td></tr> </table> </td> <td> <table style="width: 100%; border-collapse: collapse;"> <tr><td style="width: 50%;">0</td><td style="width: 50%;">0</td></tr> <tr><td style="width: 50%;">18</td><td style="width: 50%;">0</td></tr> <tr><td style="width: 50%;">0</td><td style="width: 50%;">6</td></tr> </table> </td> </tr> </table>	<table style="width: 100%; border-collapse: collapse;"> <tr><td style="width: 50%;">←14</td><td style="width: 50%;">←7</td></tr> <tr><td style="width: 50%;">←7</td><td style="width: 50%;">←24</td></tr> <tr><td style="width: 50%;">←5</td><td style="width: 50%;">←8</td></tr> </table>	←14	←7	←7	←24	←5	←8	<table style="width: 100%; border-collapse: collapse;"> <tr><td style="width: 50%;">←8</td><td style="width: 50%;">←23</td></tr> <tr><td style="width: 50%;">←8</td><td style="width: 50%;">←8</td></tr> </table>	←8	←23	←8	←8	<table style="width: 100%; border-collapse: collapse;"> <tr><td style="width: 50%;">25</td><td style="width: 50%;">0</td></tr> <tr><td style="width: 50%;">5</td><td style="width: 50%;">10</td></tr> <tr><td style="width: 50%;">0</td><td style="width: 50%;">2</td></tr> </table>	25	0	5	10	0	2	<table style="width: 100%; border-collapse: collapse;"> <tr><td style="width: 50%;">0</td><td style="width: 50%;">0</td></tr> <tr><td style="width: 50%;">18</td><td style="width: 50%;">0</td></tr> <tr><td style="width: 50%;">0</td><td style="width: 50%;">6</td></tr> </table>	0	0	18	0	0	6	<table style="width: 100%; border-collapse: collapse;"> <tr><td style="width: 50%;">0</td><td style="width: 50%;">12</td></tr> <tr><td style="width: 50%;">0</td><td style="width: 50%;">0</td></tr> </table>	0	12	0	0	<table style="width: 100%; border-collapse: collapse;"> <tr><td style="width: 50%;">←0</td><td style="width: 50%;">←0</td></tr> <tr><td style="width: 50%;">←0</td><td style="width: 50%;">←0</td></tr> <tr><td style="width: 50%;">←0</td><td style="width: 50%;">←0</td></tr> </table>	←0	←0	←0	←0	←0	←0
<table style="width: 100%; border-collapse: collapse;"> <tr><td style="width: 50%;">←14</td><td style="width: 50%;">←7</td></tr> <tr><td style="width: 50%;">←7</td><td style="width: 50%;">←24</td></tr> <tr><td style="width: 50%;">←5</td><td style="width: 50%;">←8</td></tr> </table>	←14	←7	←7	←24	←5	←8	<table style="width: 100%; border-collapse: collapse;"> <tr><td style="width: 50%;">←8</td><td style="width: 50%;">←23</td></tr> <tr><td style="width: 50%;">←8</td><td style="width: 50%;">←8</td></tr> </table>	←8	←23	←8	←8																											
←14	←7																																					
←7	←24																																					
←5	←8																																					
←8	←23																																					
←8	←8																																					
<table style="width: 100%; border-collapse: collapse;"> <tr><td style="width: 50%;">25</td><td style="width: 50%;">0</td></tr> <tr><td style="width: 50%;">5</td><td style="width: 50%;">10</td></tr> <tr><td style="width: 50%;">0</td><td style="width: 50%;">2</td></tr> </table>	25	0	5	10	0	2	<table style="width: 100%; border-collapse: collapse;"> <tr><td style="width: 50%;">0</td><td style="width: 50%;">0</td></tr> <tr><td style="width: 50%;">18</td><td style="width: 50%;">0</td></tr> <tr><td style="width: 50%;">0</td><td style="width: 50%;">6</td></tr> </table>	0	0	18	0	0	6																									
25	0																																					
5	10																																					
0	2																																					
0	0																																					
18	0																																					
0	6																																					
0	12																																					
0	0																																					
←0	←0																																					
←0	←0																																					
←0	←0																																					
4. Mt. Vernon Ave. / Spring St.	5. Mt. Vernon Ave. / Project Dwy. 1	6. Mt. Vernon Ave. / Project Dwy. 2																																				
<table style="width: 100%; border-collapse: collapse;"> <tr> <td style="width: 50%; border-right: 1px solid black;"> <table style="width: 100%; border-collapse: collapse;"> <tr><td style="width: 50%;">←4</td><td style="width: 50%;">←0</td></tr> <tr><td style="width: 50%;">←12</td><td style="width: 50%;">←0</td></tr> <tr><td style="width: 50%;">←0</td><td style="width: 50%;">←0</td></tr> </table> </td> <td style="width: 50%;"> <table style="width: 100%; border-collapse: collapse;"> <tr><td style="width: 50%;">←7</td><td style="width: 50%;">←24</td></tr> </table> </td> </tr> <tr> <td style="border-right: 1px solid black;"> <table style="width: 100%; border-collapse: collapse;"> <tr><td style="width: 50%;">3</td><td style="width: 50%;">0</td></tr> <tr><td style="width: 50%;">0</td><td style="width: 50%;">9</td></tr> <tr><td style="width: 50%;">0</td><td style="width: 50%;">0</td></tr> </table> </td> <td> <table style="width: 100%; border-collapse: collapse;"> <tr><td style="width: 50%;">12</td><td style="width: 50%;">20</td></tr> </table> </td> </tr> </table>	<table style="width: 100%; border-collapse: collapse;"> <tr><td style="width: 50%;">←4</td><td style="width: 50%;">←0</td></tr> <tr><td style="width: 50%;">←12</td><td style="width: 50%;">←0</td></tr> <tr><td style="width: 50%;">←0</td><td style="width: 50%;">←0</td></tr> </table>	←4	←0	←12	←0	←0	←0	<table style="width: 100%; border-collapse: collapse;"> <tr><td style="width: 50%;">←7</td><td style="width: 50%;">←24</td></tr> </table>	←7	←24	<table style="width: 100%; border-collapse: collapse;"> <tr><td style="width: 50%;">3</td><td style="width: 50%;">0</td></tr> <tr><td style="width: 50%;">0</td><td style="width: 50%;">9</td></tr> <tr><td style="width: 50%;">0</td><td style="width: 50%;">0</td></tr> </table>	3	0	0	9	0	0	<table style="width: 100%; border-collapse: collapse;"> <tr><td style="width: 50%;">12</td><td style="width: 50%;">20</td></tr> </table>	12	20	<table style="width: 100%; border-collapse: collapse;"> <tr><td style="width: 50%;">←3</td><td style="width: 50%;">←13</td></tr> </table>	←3	←13	<table style="width: 100%; border-collapse: collapse;"> <tr><td style="width: 50%;">←27</td><td style="width: 50%;">←5</td></tr> </table>	←27	←5												
<table style="width: 100%; border-collapse: collapse;"> <tr><td style="width: 50%;">←4</td><td style="width: 50%;">←0</td></tr> <tr><td style="width: 50%;">←12</td><td style="width: 50%;">←0</td></tr> <tr><td style="width: 50%;">←0</td><td style="width: 50%;">←0</td></tr> </table>	←4	←0	←12	←0	←0	←0	<table style="width: 100%; border-collapse: collapse;"> <tr><td style="width: 50%;">←7</td><td style="width: 50%;">←24</td></tr> </table>	←7	←24																													
←4	←0																																					
←12	←0																																					
←0	←0																																					
←7	←24																																					
<table style="width: 100%; border-collapse: collapse;"> <tr><td style="width: 50%;">3</td><td style="width: 50%;">0</td></tr> <tr><td style="width: 50%;">0</td><td style="width: 50%;">9</td></tr> <tr><td style="width: 50%;">0</td><td style="width: 50%;">0</td></tr> </table>	3	0	0	9	0	0	<table style="width: 100%; border-collapse: collapse;"> <tr><td style="width: 50%;">12</td><td style="width: 50%;">20</td></tr> </table>	12	20																													
3	0																																					
0	9																																					
0	0																																					
12	20																																					
←3	←13																																					
←27	←5																																					
<table style="width: 100%; border-collapse: collapse;"> <tr><td style="width: 50%;">←12</td><td style="width: 50%;">←3</td></tr> <tr><td style="width: 50%;">←28</td><td style="width: 50%;">←28</td></tr> </table>	←12	←3	←28	←28	<table style="width: 100%; border-collapse: collapse;"> <tr><td style="width: 50%;">←28</td><td style="width: 50%;">←1</td></tr> <tr><td style="width: 50%;">←1</td><td style="width: 50%;">←3</td></tr> </table>	←28	←1	←1	←3																													
←12	←3																																					
←28	←28																																					
←28	←1																																					
←1	←3																																					
<table style="width: 100%; border-collapse: collapse;"> <tr><td style="width: 50%;">12</td><td style="width: 50%;">0</td></tr> </table>	12	0	<table style="width: 100%; border-collapse: collapse;"> <tr><td style="width: 50%;">10</td><td style="width: 50%;">2</td></tr> </table>	10	2																																	
12	0																																					
10	2																																					

**PROJECT PASS-BY:**

5. Mt. Vernon Ave. / Project Dwy. 1	6. Mt. Vernon Ave. / Project Dwy. 2										
<table style="width: 100%; border-collapse: collapse;"> <tr><td style="width: 50%;">←20</td><td style="width: 50%;">←32</td></tr> <tr><td style="width: 50%;">←20</td><td style="width: 50%;">←20</td></tr> <tr><td style="width: 50%;">←32</td><td style="width: 50%;">←32</td></tr> </table>	←20	←32	←20	←20	←32	←32	<table style="width: 100%; border-collapse: collapse;"> <tr><td style="width: 50%;">←0</td><td style="width: 50%;">←24</td></tr> <tr><td style="width: 50%;">←24</td><td style="width: 50%;">←24</td></tr> </table>	←0	←24	←24	←24
←20	←32										
←20	←20										
←32	←32										
←0	←24										
←24	←24										
7. Project Dwy. 3 / Center St.	8. Project Dwy. 4 / Center St.										
<table style="width: 100%; border-collapse: collapse;"> <tr><td style="width: 50%;">←4</td><td style="width: 50%;">←4</td></tr> <tr><td style="width: 50%;">←4</td><td style="width: 50%;">←4</td></tr> </table>	←4	←4	←4	←4	<table style="width: 100%; border-collapse: collapse;"> <tr><td style="width: 50%;">0</td><td style="width: 50%;">0</td></tr> <tr><td style="width: 50%;">0</td><td style="width: 50%;">0</td></tr> </table>	0	0	0	0		
←4	←4										
←4	←4										
0	0										
0	0										
<table style="width: 100%; border-collapse: collapse;"> <tr><td style="width: 50%;">0</td><td style="width: 50%;">0</td></tr> </table>	0	0	<table style="width: 100%; border-collapse: collapse;"> <tr><td style="width: 50%;">0</td><td style="width: 50%;">0</td></tr> </table>	0	0						
0	0										
0	0										



# FIGURE 4-C PROJECT & PASS-BY PM PEAK HOUR INTERSECTION VOLUMES

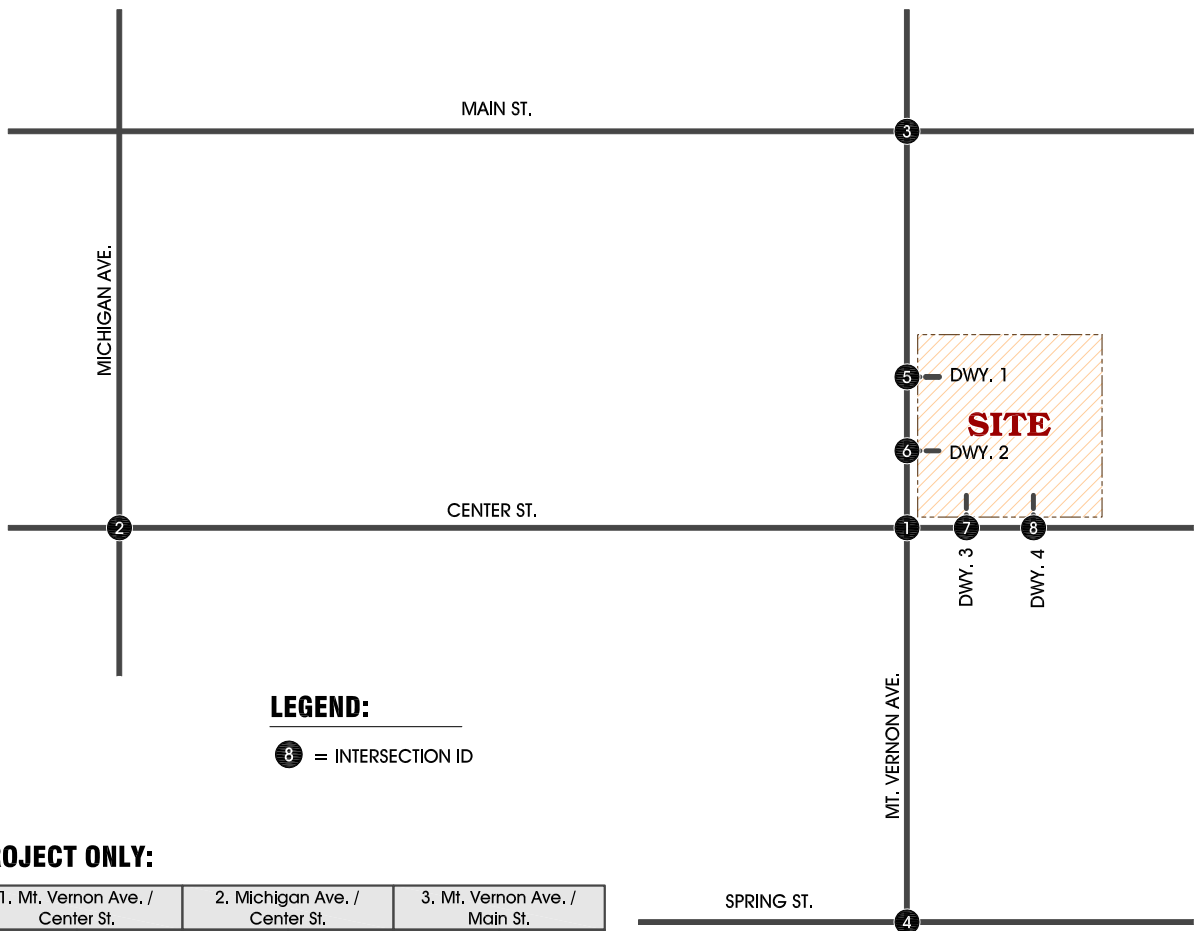

**PROJECT ONLY:**

1. Mt. Vernon Ave. / Center St.	2. Michigan Ave. / Center St.	3. Mt. Vernon Ave. / Main St.																		
<table style="width: 100%; border-collapse: collapse;"> <tr> <td style="border: none;">↖ 18</td> <td style="border: none;">↖ 5</td> </tr> <tr> <td style="border: none;">↘ 9</td> <td style="border: none;">↘ 22</td> </tr> <tr> <td style="border: none;">↙ 11</td> <td style="border: none;">↙ 7</td> </tr> </table>	↖ 18	↖ 5	↘ 9	↘ 22	↙ 11	↙ 7	<table style="width: 100%; border-collapse: collapse;"> <tr> <td style="border: none;">↖ 0</td> <td style="border: none;">↖ 8</td> </tr> <tr> <td style="border: none;">↘ 0</td> <td style="border: none;">↘ 24</td> </tr> <tr> <td style="border: none;">↙ 9</td> <td style="border: none;">↙ 8</td> </tr> </table>	↖ 0	↖ 8	↘ 0	↘ 24	↙ 9	↙ 8	<table style="width: 100%; border-collapse: collapse;"> <tr> <td style="border: none;">↖ 0</td> <td style="border: none;">↖ 0</td> </tr> <tr> <td style="border: none;">↘ 18</td> <td style="border: none;">↘ 0</td> </tr> <tr> <td style="border: none;">↙ 0</td> <td style="border: none;">↙ 0</td> </tr> </table>	↖ 0	↖ 0	↘ 18	↘ 0	↙ 0	↙ 0
↖ 18	↖ 5																			
↘ 9	↘ 22																			
↙ 11	↙ 7																			
↖ 0	↖ 8																			
↘ 0	↘ 24																			
↙ 9	↙ 8																			
↖ 0	↖ 0																			
↘ 18	↘ 0																			
↙ 0	↙ 0																			
<table style="width: 100%; border-collapse: collapse;"> <tr> <td style="border: none;">↖ 29</td> <td style="border: none;">↖ 0</td> </tr> <tr> <td style="border: none;">↘ 16</td> <td style="border: none;">↘ 12</td> </tr> <tr> <td style="border: none;">↙ 0</td> <td style="border: none;">↙ 6</td> </tr> </table>	↖ 29	↖ 0	↘ 16	↘ 12	↙ 0	↙ 6	<table style="width: 100%; border-collapse: collapse;"> <tr> <td style="border: none;">↖ 0</td> <td style="border: none;">↖ 0</td> </tr> <tr> <td style="border: none;">↘ 27</td> <td style="border: none;">↘ 0</td> </tr> <tr> <td style="border: none;">↙ 0</td> <td style="border: none;">↙ 9</td> </tr> </table>	↖ 0	↖ 0	↘ 27	↘ 0	↙ 0	↙ 9	<table style="width: 100%; border-collapse: collapse;"> <tr> <td style="border: none;">↖ 0</td> <td style="border: none;">↖ 4</td> </tr> <tr> <td style="border: none;">↘ 0</td> <td style="border: none;">↘ 16</td> </tr> <tr> <td style="border: none;">↙ 5</td> <td style="border: none;">↙ 0</td> </tr> </table>	↖ 0	↖ 4	↘ 0	↘ 16	↙ 5	↙ 0
↖ 29	↖ 0																			
↘ 16	↘ 12																			
↙ 0	↙ 6																			
↖ 0	↖ 0																			
↘ 27	↘ 0																			
↙ 0	↙ 9																			
↖ 0	↖ 4																			
↘ 0	↘ 16																			
↙ 5	↙ 0																			
4. Mt. Vernon Ave. / Spring St.	5. Mt. Vernon Ave. / Project Dwy. 1	6. Mt. Vernon Ave. / Project Dwy. 2																		
<table style="width: 100%; border-collapse: collapse;"> <tr> <td style="border: none;">↖ 4</td> <td style="border: none;">↖ 0</td> </tr> <tr> <td style="border: none;">↘ 12</td> <td style="border: none;">↘ 0</td> </tr> <tr> <td style="border: none;">↙ 0</td> <td style="border: none;">↙ 0</td> </tr> </table>	↖ 4	↖ 0	↘ 12	↘ 0	↙ 0	↙ 0	<table style="width: 100%; border-collapse: collapse;"> <tr> <td style="border: none;">↖ 8</td> <td style="border: none;">↖ 9</td> </tr> <tr> <td style="border: none;">↘ 15</td> <td style="border: none;">↘ 30</td> </tr> <tr> <td style="border: none;">↙ 11</td> <td style="border: none;">↙ 23</td> </tr> </table>	↖ 8	↖ 9	↘ 15	↘ 30	↙ 11	↙ 23	<table style="width: 100%; border-collapse: collapse;"> <tr> <td style="border: none;">↖ 38</td> <td style="border: none;">↖ 6</td> </tr> <tr> <td style="border: none;">↘ 28</td> <td style="border: none;">↘ 17</td> </tr> <tr> <td style="border: none;">↙ 17</td> <td style="border: none;">↙ 0</td> </tr> </table>	↖ 38	↖ 6	↘ 28	↘ 17	↙ 17	↙ 0
↖ 4	↖ 0																			
↘ 12	↘ 0																			
↙ 0	↙ 0																			
↖ 8	↖ 9																			
↘ 15	↘ 30																			
↙ 11	↙ 23																			
↖ 38	↖ 6																			
↘ 28	↘ 17																			
↙ 17	↙ 0																			
<table style="width: 100%; border-collapse: collapse;"> <tr> <td style="border: none;">↖ 5</td> <td style="border: none;">↖ 0</td> </tr> <tr> <td style="border: none;">↘ 0</td> <td style="border: none;">↘ 14</td> </tr> <tr> <td style="border: none;">↙ 0</td> <td style="border: none;">↙ 0</td> </tr> </table>	↖ 5	↖ 0	↘ 0	↘ 14	↙ 0	↙ 0														
↖ 5	↖ 0																			
↘ 0	↘ 14																			
↙ 0	↙ 0																			
7. Project Dwy. 3 / Center St.	8. Project Dwy. 4 / Center St.																			
<table style="width: 100%; border-collapse: collapse;"> <tr> <td style="border: none;">↖ 15</td> <td style="border: none;">↖ 3</td> </tr> <tr> <td style="border: none;">↘ 0</td> <td style="border: none;">↘ 18</td> </tr> <tr> <td style="border: none;">↙ 0</td> <td style="border: none;">↙ 0</td> </tr> </table>	↖ 15	↖ 3	↘ 0	↘ 18	↙ 0	↙ 0	<table style="width: 100%; border-collapse: collapse;"> <tr> <td style="border: none;">↖ 18</td> <td style="border: none;">↖ 2</td> </tr> <tr> <td style="border: none;">↘ 1</td> <td style="border: none;">↘ 3</td> </tr> <tr> <td style="border: none;">↙ 0</td> <td style="border: none;">↙ 0</td> </tr> </table>	↖ 18	↖ 2	↘ 1	↘ 3	↙ 0	↙ 0							
↖ 15	↖ 3																			
↘ 0	↘ 18																			
↙ 0	↙ 0																			
↖ 18	↖ 2																			
↘ 1	↘ 3																			
↙ 0	↙ 0																			
<table style="width: 100%; border-collapse: collapse;"> <tr> <td style="border: none;">↖ 33</td> <td style="border: none;">↖ 0</td> </tr> <tr> <td style="border: none;">↘ 0</td> <td style="border: none;">↘ 0</td> </tr> <tr> <td style="border: none;">↙ 0</td> <td style="border: none;">↙ 0</td> </tr> </table>	↖ 33	↖ 0	↘ 0	↘ 0	↙ 0	↙ 0	<table style="width: 100%; border-collapse: collapse;"> <tr> <td style="border: none;">↖ 30</td> <td style="border: none;">↖ 0</td> </tr> <tr> <td style="border: none;">↘ 3</td> <td style="border: none;">↘ 0</td> </tr> <tr> <td style="border: none;">↙ 0</td> <td style="border: none;">↙ 0</td> </tr> </table>	↖ 30	↖ 0	↘ 3	↘ 0	↙ 0	↙ 0							
↖ 33	↖ 0																			
↘ 0	↘ 0																			
↙ 0	↙ 0																			
↖ 30	↖ 0																			
↘ 3	↘ 0																			
↙ 0	↙ 0																			

**PROJECT PASS-BY:**

5. Mt. Vernon Ave. / Project Dwy. 1	6. Mt. Vernon Ave. / Project Dwy. 2												
<table style="width: 100%; border-collapse: collapse;"> <tr> <td style="border: none;">↖ -24</td> <td style="border: none;">↖ +38</td> </tr> <tr> <td style="border: none;">↘ +24</td> <td style="border: none;">↘ +24</td> </tr> <tr> <td style="border: none;">↙ -38</td> <td style="border: none;">↙ +29</td> </tr> </table>	↖ -24	↖ +38	↘ +24	↘ +24	↙ -38	↙ +29	<table style="width: 100%; border-collapse: collapse;"> <tr> <td style="border: none;">↖ 0</td> <td style="border: none;">↖ +29</td> </tr> <tr> <td style="border: none;">↘ -38</td> <td style="border: none;">↘ -29</td> </tr> <tr> <td style="border: none;">↙ +38</td> <td style="border: none;">↙ +29</td> </tr> </table>	↖ 0	↖ +29	↘ -38	↘ -29	↙ +38	↙ +29
↖ -24	↖ +38												
↘ +24	↘ +24												
↙ -38	↙ +29												
↖ 0	↖ +29												
↘ -38	↘ -29												
↙ +38	↙ +29												
7. Project Dwy. 3 / Center St.	8. Project Dwy. 4 / Center St.												
<table style="width: 100%; border-collapse: collapse;"> <tr> <td style="border: none;">↖ +5</td> <td style="border: none;">↖ +5</td> </tr> <tr> <td style="border: none;">↘ +5</td> <td style="border: none;">↘ +5</td> </tr> <tr> <td style="border: none;">↙ 0</td> <td style="border: none;">↙ 0</td> </tr> </table>	↖ +5	↖ +5	↘ +5	↘ +5	↙ 0	↙ 0	<table style="width: 100%; border-collapse: collapse;"> <tr> <td style="border: none;">↖ 0</td> <td style="border: none;">↖ 0</td> </tr> <tr> <td style="border: none;">↘ 0</td> <td style="border: none;">↘ 0</td> </tr> <tr> <td style="border: none;">↙ 0</td> <td style="border: none;">↙ 0</td> </tr> </table>	↖ 0	↖ 0	↘ 0	↘ 0	↙ 0	↙ 0
↖ +5	↖ +5												
↘ +5	↘ +5												
↙ 0	↙ 0												
↖ 0	↖ 0												
↘ 0	↘ 0												
↙ 0	↙ 0												
<table style="width: 100%; border-collapse: collapse;"> <tr> <td style="border: none;">↖ 0</td> <td style="border: none;">↖ 0</td> </tr> <tr> <td style="border: none;">↘ 0</td> <td style="border: none;">↘ 0</td> </tr> <tr> <td style="border: none;">↙ 0</td> <td style="border: none;">↙ 0</td> </tr> </table>	↖ 0	↖ 0	↘ 0	↘ 0	↙ 0	↙ 0	<table style="width: 100%; border-collapse: collapse;"> <tr> <td style="border: none;">↖ 0</td> <td style="border: none;">↖ 0</td> </tr> <tr> <td style="border: none;">↘ 0</td> <td style="border: none;">↘ 0</td> </tr> <tr> <td style="border: none;">↙ 0</td> <td style="border: none;">↙ 0</td> </tr> </table>	↖ 0	↖ 0	↘ 0	↘ 0	↙ 0	↙ 0
↖ 0	↖ 0												
↘ 0	↘ 0												
↙ 0	↙ 0												
↖ 0	↖ 0												
↘ 0	↘ 0												
↙ 0	↙ 0												



# FIGURE 4-D CUMULATIVE DEVELOPMENTS LOCATION MAP

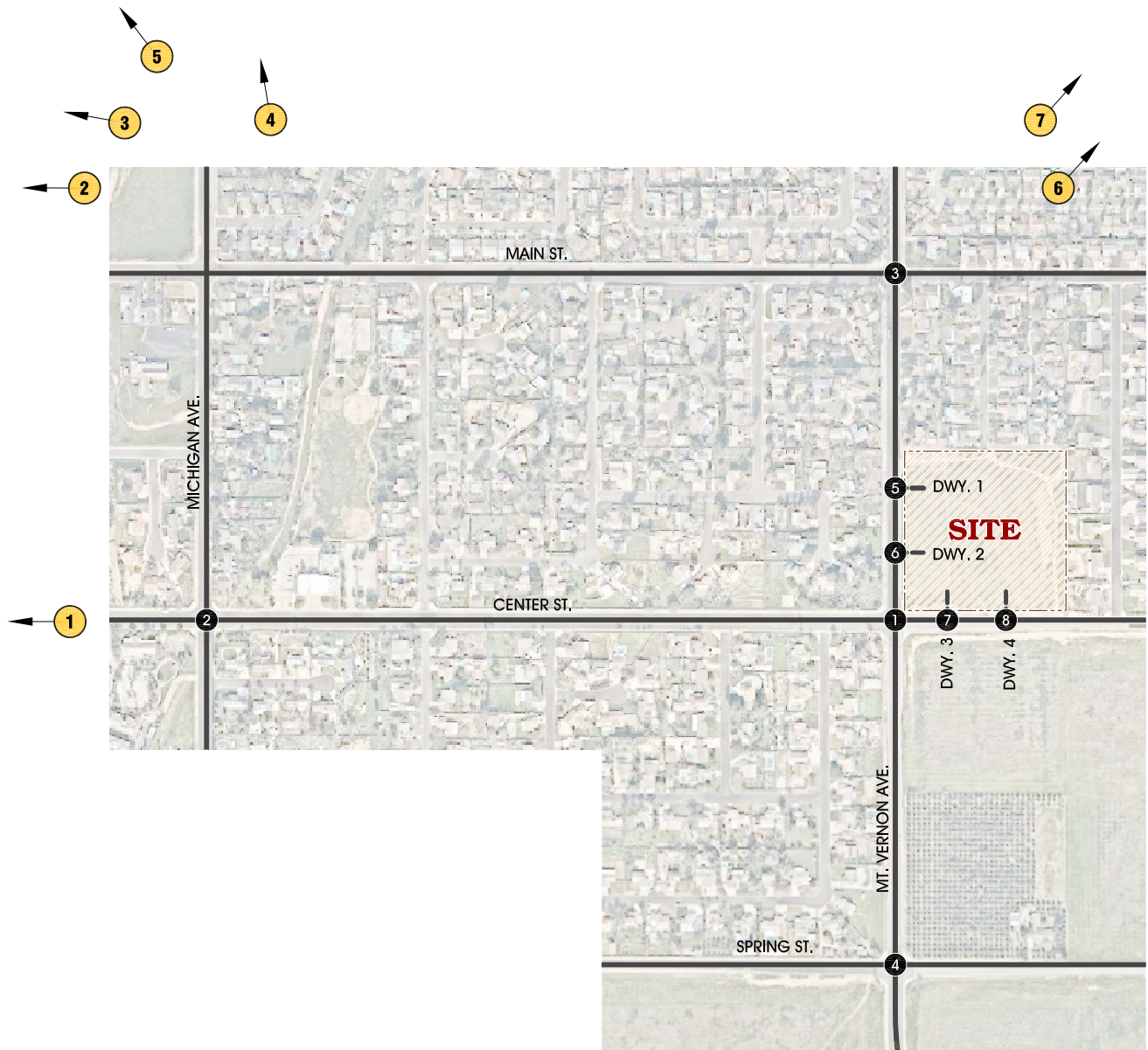

**LEGEND:**

- 6 = INTERSECTION ID
- 7 = CUMULATIVE DEVELOPMENT ID  
(SEE TABLE 4-3 FOR REFERENCE)



3. Other Approved Projects Trip Generation

Table 4-3 presents the cumulative development land uses and trip generation summary. As presented in Table 4-3 Cumulative developments are projected to generate a total of approximately 21,376 trip-ends per day with 945 vehicle trips per hour during the AM peak hour and 1,913 vehicle trips per hour during the PM peak hour.

4. Total Background Peak Hour Turning Movement Volumes

Based on the identified trip distribution for the cumulative development on arterial highways throughout the study area, cumulative development AM and PM peak hour intersection turning movement volumes are shown on Figure 4-E and 4-F, respectively.

Existing plus Project (E+P) AM and PM peak hour intersection turning movement volumes are shown on Figure 4-G and 4-H, respectively.

Existing plus Ambient plus Project (E+A+P) AM and PM peak hour intersection turning movement volumes are shown on Figure 4-I and 4-J, respectively.

Existing plus Ambient plus Project plus Cumulative (E+A+P+C) AM and PM peak hour intersection turning movement volumes are shown on Figure 4-K and 4-L, respectively.

**TABLE 4-3**

**CUMULATIVE DEVELOPMENT TRIP GENERATION SUMMARY**

ID	PROJECT NAME	LAND USE	QUANTITY <sup>1</sup>	PEAK HOUR						DAILY
				AM			PM			
				IN	OUT	TOTAL	IN	OUT	TOTAL	
1	CUP3763	Gasoline/Service Station w/ Convenience Market	12 VFP	76	73	149	86	82	168	2,464
	PP25505	Truck Sales Facility	8.852 TSF	12	4	16	9	13	22	246
	CUP190008	Marijuana Dispensary	3.802 TSF	22	17	39	42	41	83	961
	CUP03761	Gasoline/Service Station w/ Convenience Market	8 VFP	51	49	100	57	55	112	1,643
	CUP190007	Marijuana Dispensary	1.203 TSF	7	6	13	13	13	26	304
	CUP190011	Marijuana Dispensary	2.52 TSF	15	12	27	28	27	55	637
	CUP190016	Marijuana Dispensary	5.4 TSF	32	25	57	59	59	118	1,365
	CUP03750	Automobile Sales	5.876 TSF	8	3	11	6	9	15	164
	Subtotal				223	189	412	300	299	599
2	National Logistics Team	Gen. Lt. Industrial	8.82 TSF	5	1	6	1	5	6	44
3	Gateway Specific Plan (Lewis Management Corp.)	Shopping Center	877.538 TSF	509	316	825	1,606	1,738	3,344	33,127
		Multifamily Housing (Low-Rise 1-2 floors)	748 DU	82	262	344	262	157	419	5,475
	Subtotal				591	578	1,169	1,868	1,895	3,763
2022 Estimated Total (30% Absorption Rate)				177	173	350	560	569	1,129	11,581
4	Taco Bell (22172 Barton Road)	Fast Food w/ Drive Thru	2.08 TSF	43	41	84	35	33	68	980
	Jai Ganesh LLC	Single Fam. Detached	2 DU	0	1	1	1	1	2	19
	Aegis Builders	Single Fam. Detached	17 DU	3	10	13	11	6	17	160
	Subtotal				46	52	98	47	40	87
5	Edwin Renewable Fuels	Gen. Lt. Industrial	80.898 TSF	50	6	56	6	44	50	401
6	Crestwood Corporation	Single Fam. Detached	17 DU	3	10	13	11	6	17	160
7	Space Masters	Medical-Dental Office	1.665 TSF	4	1	5	2	4	6	58
	Ajay Roberts	Shopping Center	4.998 TSF	3	2	5	9	10	19	189
	Subtotal				7	3	10	11	14	25
<b>Total Cumulative Projects Trips</b>				<b>511</b>	<b>434</b>	<b>945</b>	<b>936</b>	<b>977</b>	<b>1,913</b>	<b>21,376</b>

<sup>1</sup> TSF = Thousand Square Feet; DU = Dwelling Units; VFP = Vehicle Fueling Positions

# FIGURE 4-E CUMULATIVE DEVELOPMENTS ONLY AM PEAK HOUR INTERSECTION VOLUMES

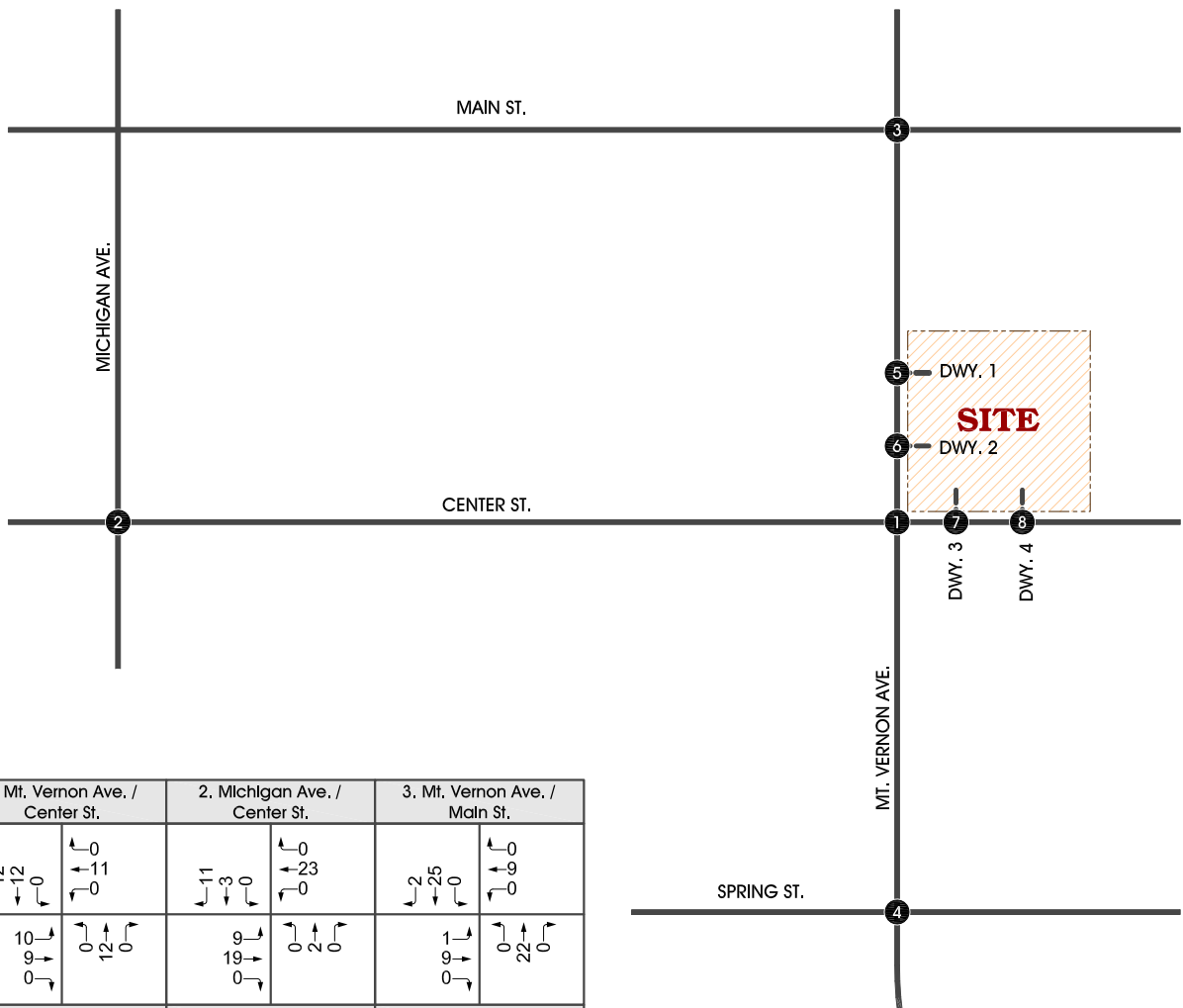

1. Mt. Vernon Ave. / Center St.	2. Michigan Ave. / Center St.	3. Mt. Vernon Ave. / Main St.
4. Mt. Vernon Ave. / Spring St.	5. Mt. Vernon Ave. / Project Dwy. 1	6. Mt. Vernon Ave. / Project Dwy. 2
	FUTURE INTERSECTION	FUTURE INTERSECTION
7. Project Dwy. 3 / Center St.	8. Project Dwy. 4 / Center St.	
FUTURE INTERSECTION	FUTURE INTERSECTION	

**LEGEND:**  
 = INTERSECTION ID



# FIGURE 4-F CUMULATIVE DEVELOPMENTS ONLY PM PEAK HOUR INTERSECTION VOLUMES

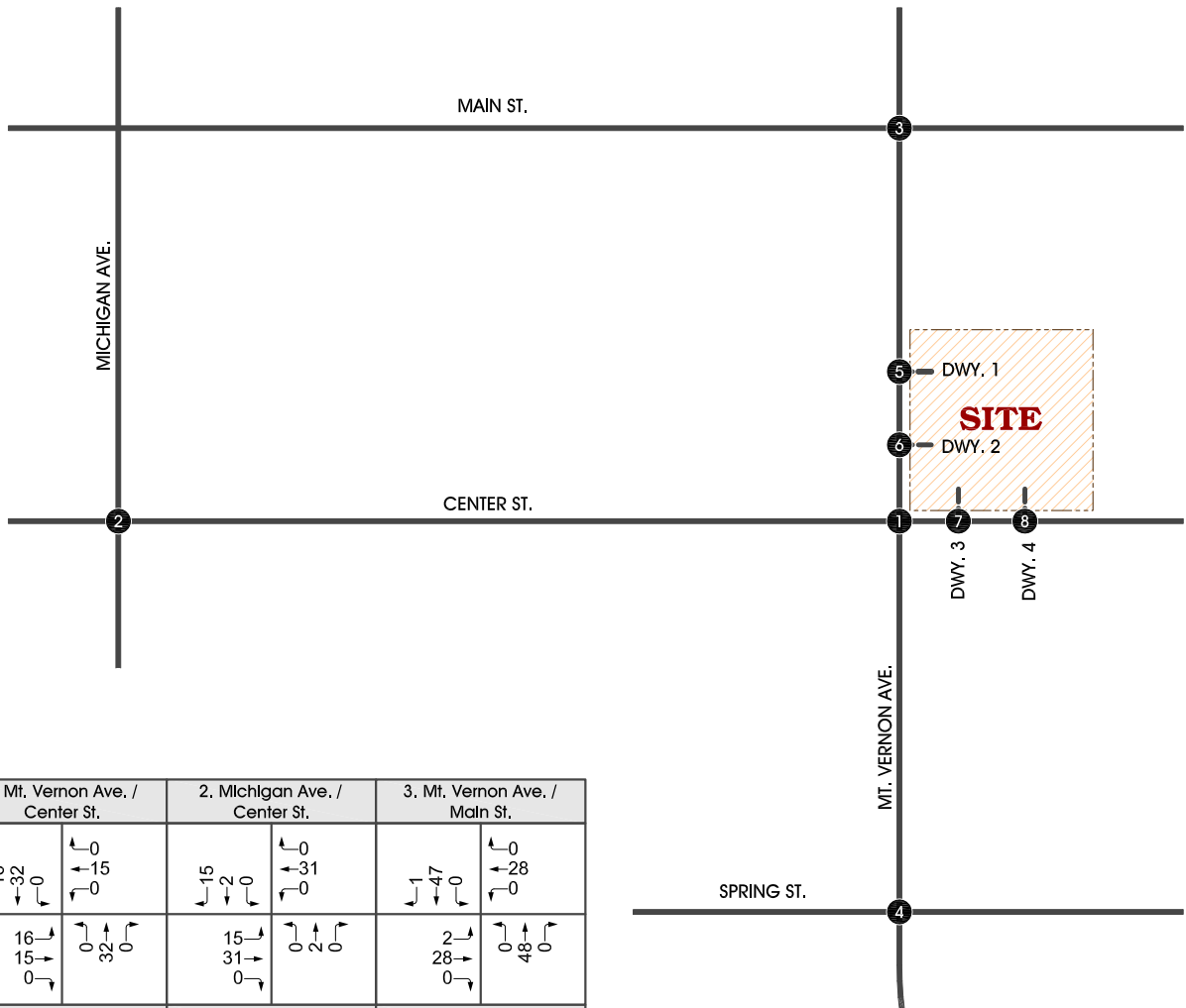

1. Mt. Vernon Ave. / Center St.	2. Michigan Ave. / Center St.	3. Mt. Vernon Ave. / Main St.
4. Mt. Vernon Ave. / Spring St.	5. Mt. Vernon Ave. / Project Dwy. 1	6. Mt. Vernon Ave. / Project Dwy. 2
	FUTURE INTERSECTION	FUTURE INTERSECTION
7. Project Dwy. 3 / Center St.	8. Project Dwy. 4 / Center St.	
FUTURE INTERSECTION	FUTURE INTERSECTION	

**LEGEND:**

⑧ = INTERSECTION ID



# FIGURE 4-G EXISTING PLUS PROJECT AM PEAK HOUR INTERSECTION VOLUMES

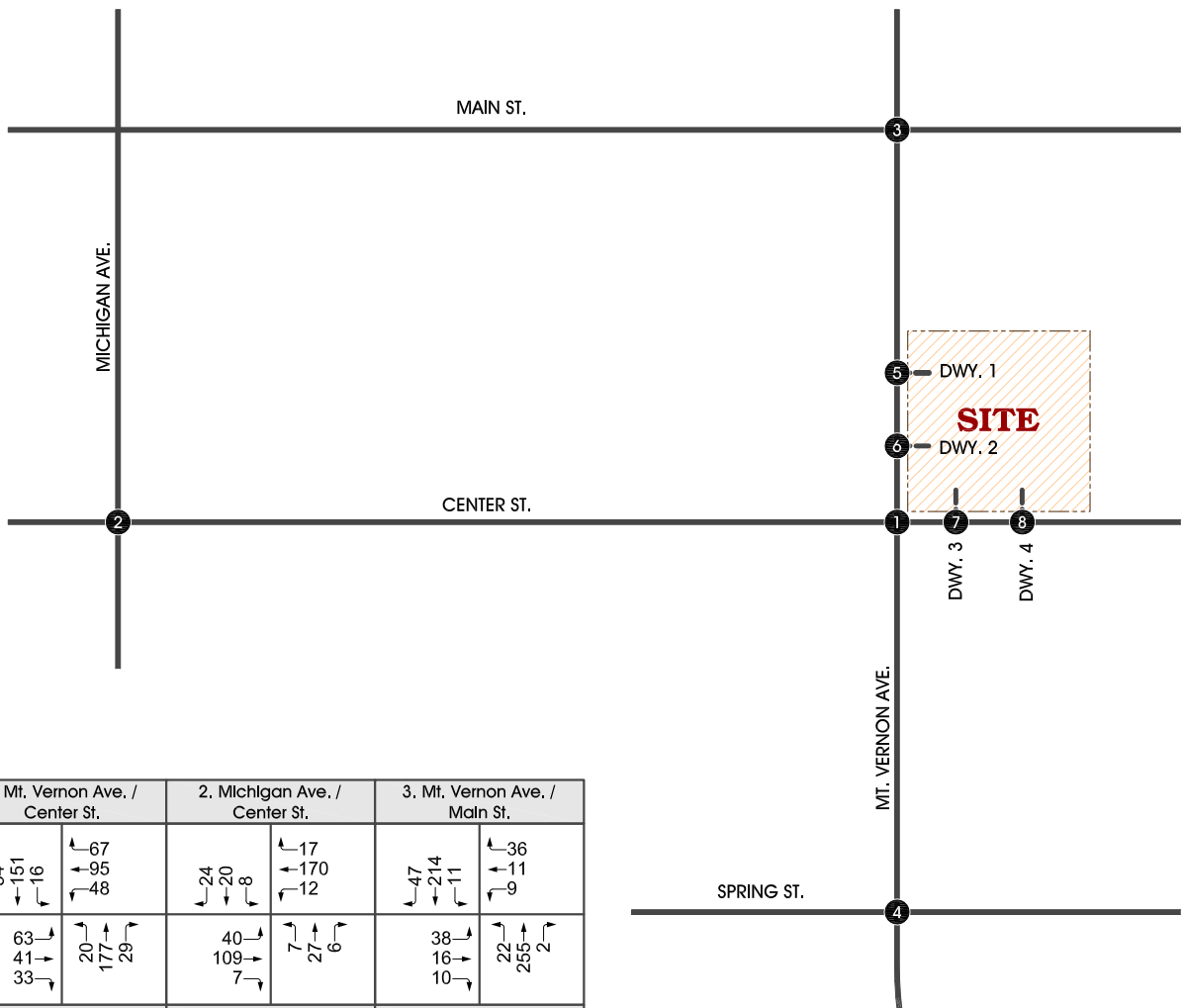

1. Mt. Vernon Ave. / Center St.	2. Michigan Ave. / Center St.	3. Mt. Vernon Ave. / Main St.
↙ 54 ↘ 151 ↖ 16 ↗ 67 ↘ 95 ↖ 48	↙ 24 ↘ 20 ↖ 8 ↗ 17 ↘ 170 ↖ 12	↙ 47 ↘ 214 ↖ 11 ↗ 36 ↘ 11 ↖ 9
↘ 63 ↖ 41 ↗ 33 ↘ 20 ↖ 177 ↗ 29	↘ 40 ↖ 109 ↗ 7 ↘ 27 ↖ 6	↘ 38 ↖ 16 ↗ 10 ↘ 22 ↖ 255 ↗ 2
4. Mt. Vernon Ave. / Spring St.	5. Mt. Vernon Ave. / Project Dwy. 1	6. Mt. Vernon Ave. / Project Dwy. 2
↙ 20 ↘ 176 ↖ 27 ↗ 91 ↘ 22 ↖ 22	↙ 178 ↘ 33 ↖ 39 ↘ 44	↙ 222 ↘ 29
↘ 12 ↖ 7 ↗ 9 ↘ 7 ↖ 144 ↗ 9	↘ 245 ↖ 52	↘ 268 ↖ 39
7. Project Dwy. 3 / Center St.	8. Project Dwy. 4 / Center St.	
↘ 16 ↖ 7 ↗ 195	↘ 28 ↖ 1 ↗ 174	
86 →	10 ↘ 76 →	

**LEGEND:**

⑧ = INTERSECTION ID



# FIGURE 4-H EXISTING PLUS PROJECT PM PEAK HOUR INTERSECTION VOLUMES

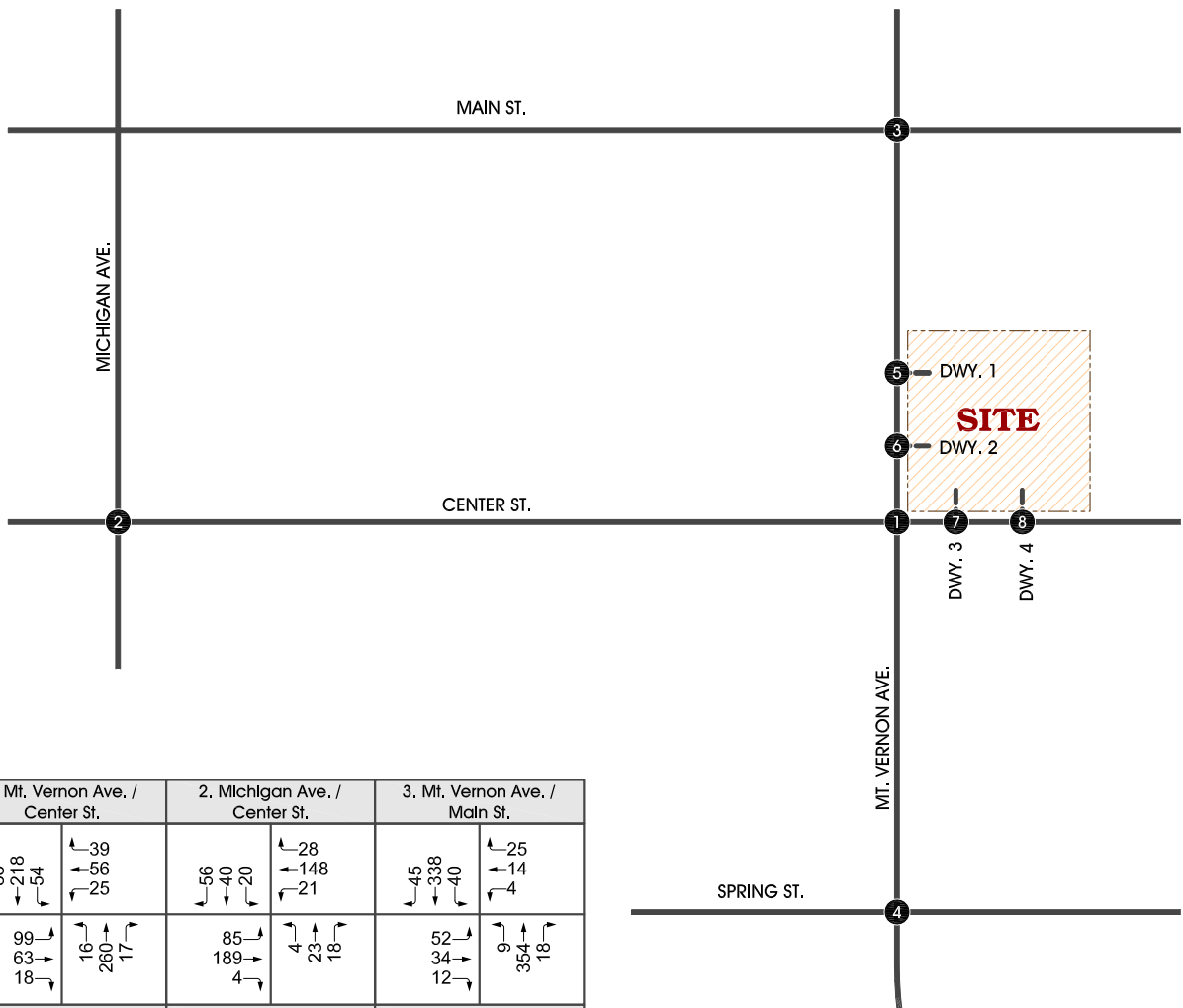

1. Mt. Vernon Ave. / Center St.	2. Michigan Ave. / Center St.	3. Mt. Vernon Ave. / Main St.
88 ← ↓ 218 → 54 ← 39 ↓ 56 → 25	56 ← ↓ 40 → 20 ← 28 ↓ 148 → 21	45 ← ↓ 338 → 40 ← 25 ↓ 14 → 4
99 → 63 → 18 → 16 → 260 → 17 →	85 → 189 → 4 → 4 → 23 → 18 →	52 → 34 → 12 → 9 → 354 → 18 →
4. Mt. Vernon Ave. / Spring St.	5. Mt. Vernon Ave. / Project Dwy. 1	6. Mt. Vernon Ave. / Project Dwy. 2
8 ← ↓ 172 → 85 ← 58 ↓ 14 → 25	306 ← ↓ 39 → 47 ↓ 54 → 54	360 ← ↓ 35 → 35 ↓ 46 → 46
14 → 20 → 5 → 11 → 232 → 32 →	325 → 61 →	
7. Project Dwy. 3 / Center St.	8. Project Dwy. 4 / Center St.	
20 ← ← 8 ← 99	18 ← ↓ 1 ← 2 ← 89	
134 →	30 → 104 →	

**LEGEND:**  
 = INTERSECTION ID



# FIGURE 4-1 EXISTING PLUS AMBIENT PLUS PROJECT (2022) AM PEAK HOUR INTERSECTION VOLUMES

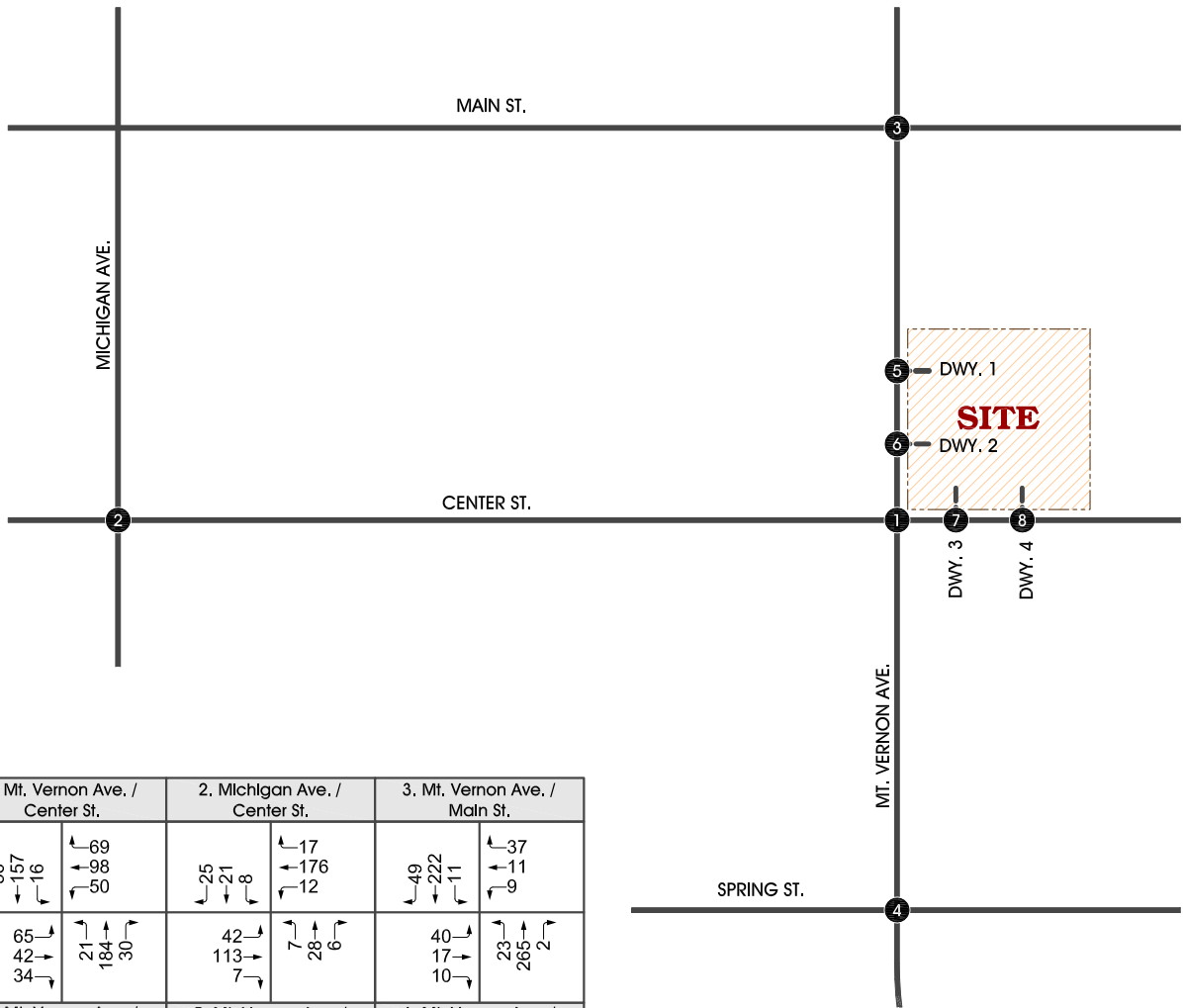

1. Mt. Vernon Ave. / Center St.	2. Michigan Ave. / Center St.	3. Mt. Vernon Ave. / Main St.
↙ 56    ↘ 157 ↖ 16    ↗ 69 ↙ 65    ↘ 21 ↖ 42    ↗ 184 ↘ 34    ↗ 30	↙ 25    ↘ 21 ↖ 8    ↗ 17 ↙ 42    ↘ 7 ↖ 113    ↗ 28 ↘ 7    ↗ 6	↙ 49    ↘ 222 ↖ 11    ↗ 37 ↙ 40    ↘ 23 ↖ 17    ↗ 265 ↘ 10    ↗ 2
4. Mt. Vernon Ave. / Spring St.	5. Mt. Vernon Ave. / Project Dwy. 1	6. Mt. Vernon Ave. / Project Dwy. 2
↙ 21    ↘ 183 ↖ 28    ↗ 95 ↙ 12    ↘ 7 ↖ 9    ↗ 149 ↘ 9    ↗ 9	↙ 186    ↘ 33 ↖ 39    ↗ 44 ↙ 266    ↘ 52	↙ 230    ↘ 29 ↖ 279    ↗ 39
7. Project Dwy. 3 / Center St.	8. Project Dwy. 4 / Center St.	
↙ 16    ↘ 7 ↖ 202    ↗ 1	↙ 28    ↘ 1 ↖ 181    ↗ 1	
88 →	10 ↘ 78 →	

**LEGEND:**  
 = INTERSECTION ID



# FIGURE 4-J EXISTING PLUS AMBIENT PLUS PROJECT (2022) PM PEAK HOUR INTERSECTION VOLUMES

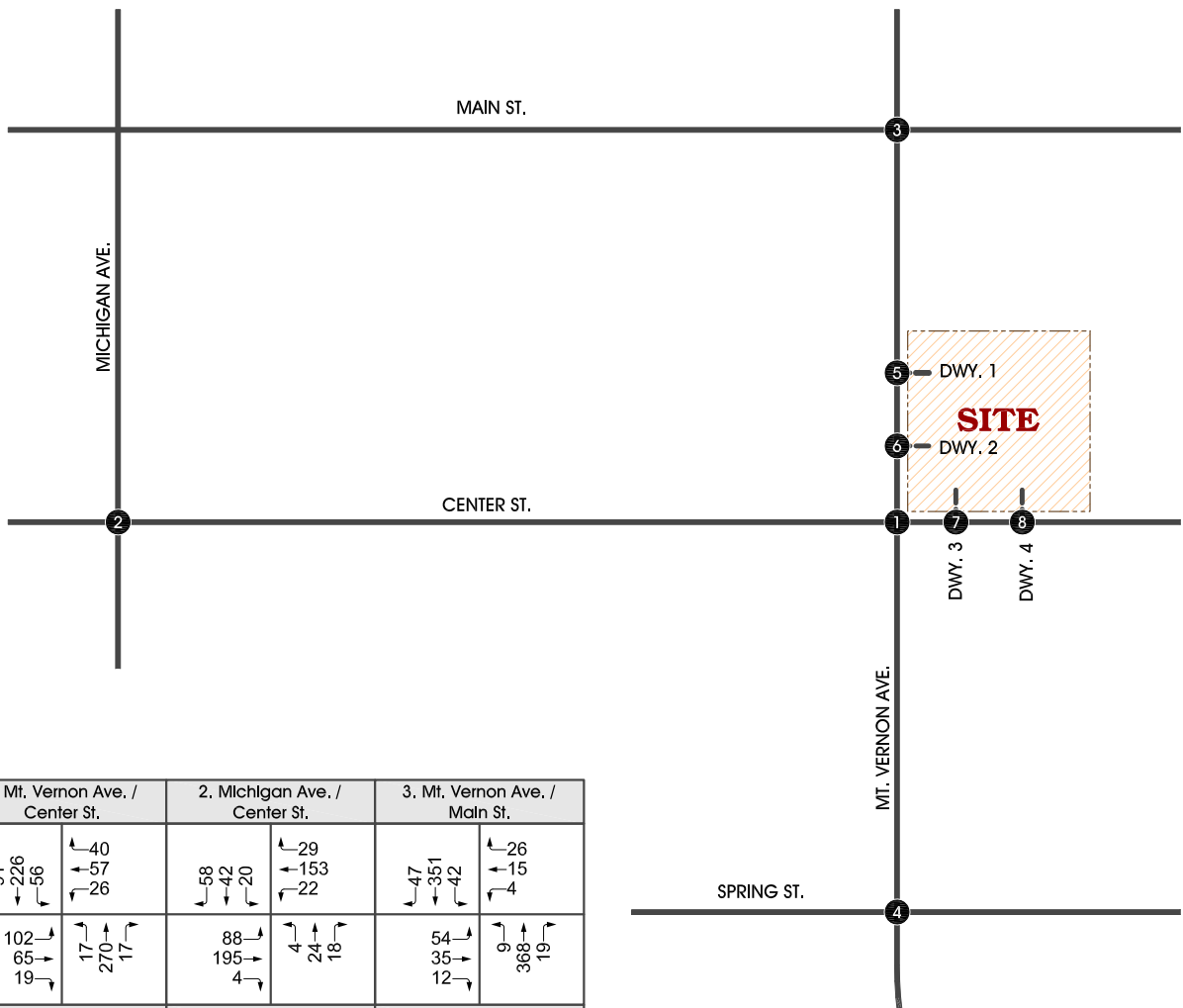

1. Mt. Vernon Ave. / Center St.	2. Michigan Ave. / Center St.	3. Mt. Vernon Ave. / Main St.
4. Mt. Vernon Ave. / Spring St.	5. Mt. Vernon Ave. / Project Dwy. 1	6. Mt. Vernon Ave. / Project Dwy. 2
7. Project Dwy. 3 / Center St.	8. Project Dwy. 4 / Center St.	

**LEGEND:**  
 = INTERSECTION ID



# FIGURE 4-K EXISTING PLUS AMBIENT PLUS PROJECT PLUS CUMULATIVE (2022) AM PEAK HOUR INTERSECTION VOLUMES

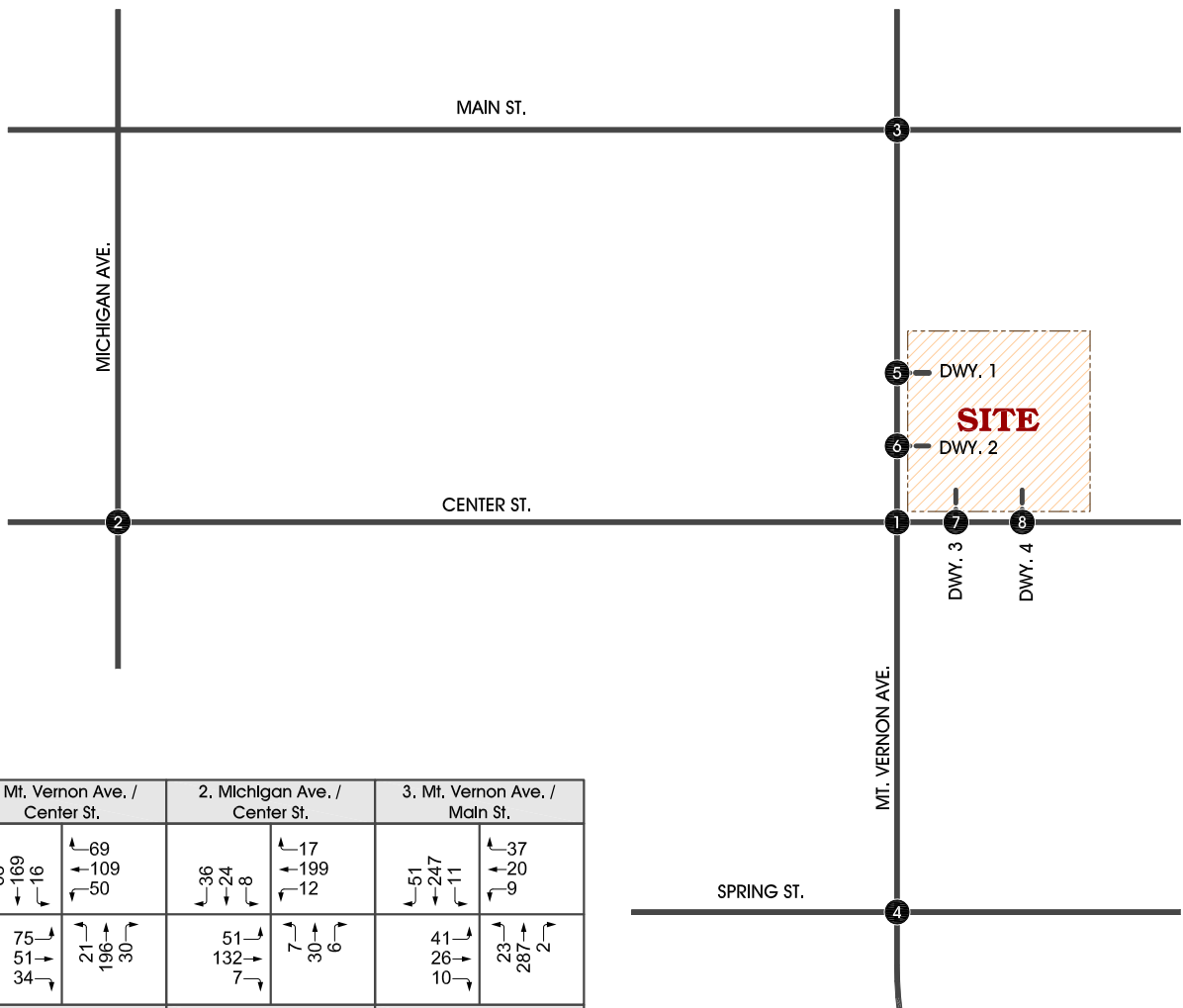

1. Mt. Vernon Ave. / Center St.	2. Michigan Ave. / Center St.	3. Mt. Vernon Ave. / Main St.
68 ← 169 → 16 →	36 ← 24 → 8 →	51 ← 247 → 11 →
75 → 51 → 34 →	51 → 132 → 7 →	41 → 26 → 10 →
21 ← 196 → 30 →	7 ← 30 → 6 →	23 ← 287 → 2 →
4. Mt. Vernon Ave. / Spring St.	5. Mt. Vernon Ave. / Project Dwy. 1	6. Mt. Vernon Ave. / Project Dwy. 2
21 ← 195 → 28 →	211 ← 33 →	255 ←
12 → 7 → 9 →	39 ← 44 →	29 →
7 ← 161 → 9 →	278 ← 52 →	301 ← 39 →
7. Project Dwy. 3 / Center St.	8. Project Dwy. 4 / Center St.	
16 →	28 → 1 →	
7 ← 213 →	1 ← 192 →	
97 →	10 → 87 →	

**LEGEND:**  
 = INTERSECTION ID



# FIGURE 4-L EXISTING PLUS AMBIENT PLUS PROJECT PLUS CUMULATIVE (2022) PM PEAK HOUR INTERSECTION VOLUMES

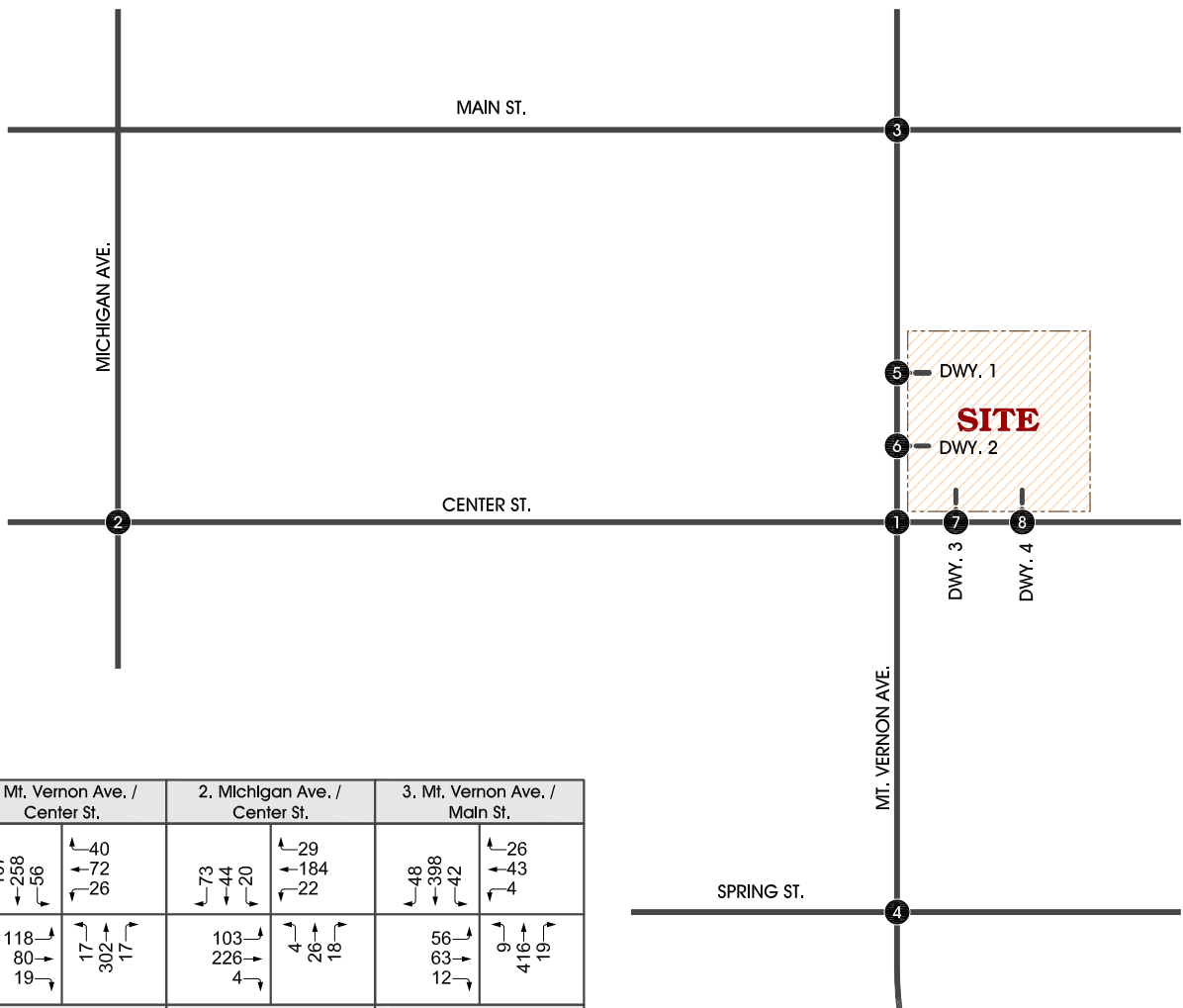

1. Mt. Vernon Ave. / Center St.	2. Michigan Ave. / Center St.	3. Mt. Vernon Ave. / Main St.																		
<table border="1"> <tr> <td>107</td> <td>40</td> </tr> <tr> <td>258</td> <td>72</td> </tr> <tr> <td>56</td> <td>26</td> </tr> </table>	107	40	258	72	56	26	<table border="1"> <tr> <td>73</td> <td>29</td> </tr> <tr> <td>44</td> <td>184</td> </tr> <tr> <td>20</td> <td>22</td> </tr> </table>	73	29	44	184	20	22	<table border="1"> <tr> <td>48</td> <td>26</td> </tr> <tr> <td>398</td> <td>43</td> </tr> <tr> <td>42</td> <td>4</td> </tr> </table>	48	26	398	43	42	4
107	40																			
258	72																			
56	26																			
73	29																			
44	184																			
20	22																			
48	26																			
398	43																			
42	4																			
<table border="1"> <tr> <td>118</td> <td>17</td> </tr> <tr> <td>80</td> <td>302</td> </tr> <tr> <td>19</td> <td>17</td> </tr> </table>	118	17	80	302	19	17	<table border="1"> <tr> <td>103</td> <td>4</td> </tr> <tr> <td>226</td> <td>26</td> </tr> <tr> <td>4</td> <td>18</td> </tr> </table>	103	4	226	26	4	18	<table border="1"> <tr> <td>56</td> <td>9</td> </tr> <tr> <td>63</td> <td>416</td> </tr> <tr> <td>12</td> <td>19</td> </tr> </table>	56	9	63	416	12	19
118	17																			
80	302																			
19	17																			
103	4																			
226	26																			
4	18																			
56	9																			
63	416																			
12	19																			
4. Mt. Vernon Ave. / Spring St.	5. Mt. Vernon Ave. / Project Dwy. 1	6. Mt. Vernon Ave. / Project Dwy. 2																		
<table border="1"> <tr> <td>8</td> <td>60</td> </tr> <tr> <td>210</td> <td>15</td> </tr> <tr> <td>88</td> <td>26</td> </tr> </table>	8	60	210	15	88	26	<table border="1"> <tr> <td>366</td> <td>47</td> </tr> <tr> <td>39</td> <td>54</td> </tr> </table>	366	47	39	54	<table border="1"> <tr> <td>420</td> <td>35</td> </tr> </table>	420	35						
8	60																			
210	15																			
88	26																			
366	47																			
39	54																			
420	35																			
<table border="1"> <tr> <td>14</td> <td>11</td> </tr> <tr> <td>21</td> <td>273</td> </tr> <tr> <td>5</td> <td>33</td> </tr> </table>	14	11	21	273	5	33	<table border="1"> <tr> <td>387</td> <td>61</td> </tr> </table>	387	61	<table border="1"> <tr> <td>413</td> <td>46</td> </tr> </table>	413	46								
14	11																			
21	273																			
5	33																			
387	61																			
413	46																			
7. Project Dwy. 3 / Center St.	8. Project Dwy. 4 / Center St.																			
<table border="1"> <tr> <td>20</td> <td>8</td> </tr> <tr> <td></td> <td>117</td> </tr> </table>	20	8		117	<table border="1"> <tr> <td>18</td> <td>2</td> </tr> <tr> <td></td> <td>107</td> </tr> </table>	18	2		107											
20	8																			
	117																			
18	2																			
	107																			
<table border="1"> <tr> <td>153</td> <td>30</td> </tr> <tr> <td></td> <td>123</td> </tr> </table>	153	30		123																
153	30																			
	123																			

**LEGEND:**

⑧ = INTERSECTION ID



THIS PAGE IS LEFT INTENTIONALLY BLANK

## 5.0 TRAFFIC ANALYSIS

---

Peak hour intersection analysis has been performed at the study area intersections for each of the project scenarios and for projected future conditions. Improvements are recommended to satisfy the level of service requirements of the County of Riverside and if the following impacts are identified:

- 1) When existing traffic conditions (Analysis Scenario 1) exceed the General Plan target LOS.
- 2) When project traffic, when added to existing traffic (Analysis Scenario 2), will deteriorate the LOS to below the target LOS, and impacts cannot be mitigated through project conditions of approval.
- 3) When cumulative traffic (Analysis Scenario 3) exceeds the target LOS, and impacts cannot be mitigated through existing infrastructure funding mechanisms.

### A. Existing plus Project (E+P) Conditions

The results of the E+P conditions intersection analysis are summarized in Table 5-1. The E+P condition operations analysis worksheets are provided in Appendix "D". The study area intersections are projected to continue to operate at an acceptable level of service (LOS "D" or better) during the peak hours with the existing geometry and traffic controls.

For analysis purpose, the following improvements (as shown on Table 5-1) are assumed in place to provide access to the Project:

#### **Mt. Vernon Ave. / Project Dwy. 1 (#5)**

- Install a stop control on the westbound approach.
- Provide a shared westbound left/right turn lane.

#### **Mt. Vernon Ave. / Project Dwy. 2 (#6)**

- Install a stop control on the westbound approach.
- Provide a westbound right turn lane.

#### **Project Dwy. 3 / Center St. (#7)**

- Install a stop control on the southbound approach.
- Provide a southbound right turn lane.

#### **Project Dwy. 4 / Center St. (#8)**

- Install a stop control on the southbound approach.
- Provide a shared southbound left/right turn lane.

**TABLE 5-1  
INTERSECTION ANALYSIS FOR  
EXISTING PLUS PROJECT CONDITIONS**

ID	Intersection	Traffic Control <sup>1</sup>	Intersection Approach Lanes <sup>2</sup>												Delay <sup>3</sup> (secs.)		Level of Service <sup>3</sup>	
			Northbound			Southbound			Eastbound			Westbound			AM	PM	AM	PM
			L	T	R	L	T	R	L	T	R	L	T	R				
1	Mt. Vernon Ave. / Center St.	TS	1	1	1	1	2	0	1	2	0	1	2	0	20.4	22.9	C	C
2	Michigan Ave. / Center St.	AWS	0.5	0.5	d	0.5	0.5	d	0.5	1.5	d	0.5	1.5	d	8.9	9.6	A	A
3	Mt. Vernon Ave. / Main St.	AWS	0.5	0.5	d	0.5	1.5	d	0.5	0.5	d	0	1!	0	11.7	18.8	B	C
4	Mt. Vernon Ave. / Spring St.	TS	1	2	0	1	1	1	1	1	0	1	1	0	16.5	18.5	B	B
5	Mt. Vernon Ave. / Project Dwy. 1	<u>CSS</u>	0	1	0	0.5	1.5	0	0	0	0	0	<u>1!</u>	0	12.0	14.3	B	B
6	Mt. Vernon Ave. / Project Dwy. 2	<u>CSS</u>	0	1	0	0	2	0	0	0	0	0	0	<u>1</u>	10.2	11.0	B	B
7	Project Dwy. 3 / Center St.	<u>CSS</u>	0	0	0	0	0	<u>1</u>	0	1	0	0	1	0	9.5	8.9	A	A
8	Project Dwy. 4 / Center St.	<u>CSS</u>	0	0	0	0	<u>1!</u>	0	0.5	0.5	0	0	1	0	9.4	8.9	A	A

<sup>1</sup> TS = Traffic Signal; AWS = All Way Stop; CSS = Cross Street Stop

<sup>2</sup> When a right turn is designated, the lane can either be striped or unstriped. To function as a right turn lane there must be sufficient width for right turning vehicles to travel outside the through lanes.

L = Left; T = Through; R = Right; 1! = Shared Left-Through-Right Lane; 0.5 = Shared Lane; d = Defacto right turn lane; 1 = Improvement

<sup>3</sup> Delay and level of service calculated using the following analysis software: Synchro 10 HCM6

B. Existing plus Ambient plus Project (E+A+P) Conditions

The results of the E+A+P conditions intersection analysis are summarized in Table 5-2. The E+A+P condition operations analysis worksheets are provided in Appendix "E". The study area intersections are projected to continue to operate at an acceptable level of service (LOS "D" or better) during the peak hours with the existing geometry and traffic controls.

C. Existing plus Ambient plus Project plus Cumulative (E+A+P+C) Conditions

The results of the E+A+P+C conditions intersection analysis are summarized in Table 5-3. The E+A+P+C condition operations analysis worksheets are provided in Appendix "F". The study area intersection of Mt. Vernon Ave. and Main St. (#3) is anticipated to operate at an unacceptable level of service (LOS "E" or worse) during the peak hours with existing geometry and will require improvements. Table 5-2 provides the recommended improvement at this intersection to allow this location to operate at acceptable service levels (LOS D or better).

The study area intersections are projected to operate at an acceptable level of service (LOS "D" or better) during the peak hours with the recommended geometry and traffic controls (listed below). It is important to note that some of these improvements may not be feasible due to right-of-way constraints.

**Mt. Vernon Ave. / Main St. (#3)**

- Northbound: Modify striping to provide a 2<sup>nd</sup> through lane.

**TABLE 5-2**  
**INTERSECTION ANALYSIS FOR**  
**EXISTING PLUS AMBIENT PLUS PROJECT (2022) CONDITIONS**

ID	Intersection	Traffic Control <sup>1</sup>	Intersection Approach Lanes <sup>2</sup>												Delay <sup>3</sup> (secs.)		Level of Service <sup>3</sup>	
			Northbound			Southbound			Eastbound			Westbound			AM	PM	AM	PM
			L	T	R	L	T	R	L	T	R	L	T	R				
1	Mt. Vernon Ave. / Center St.	TS	1	1	1	1	2	0	1	2	0	1	2	0	20.5	23.7	C	C
2	Michigan Ave. / Center St.	AWS	0.5	0.5	d	0.5	0.5	d	0.5	1.5	d	0.5	1.5	d	9.0	9.8	A	A
3	Mt. Vernon Ave. / Main St.	AWS	0.5	0.5	d	0.5	1.5	d	0.5	0.5	d	0	1!	0	12.1	20.7	B	C
4	Mt. Vernon Ave. / Spring St.	TS	1	2	0	1	1	1	1	1	0	1	1	0	16.7	19.3	B	B
5	Mt. Vernon Ave. / Project Dwy. 1	<u>CSS</u>	0	1	0	0.5	1.5	0	0	0	0	0	<u>1!</u>	0	12.1	14.7	B	B
6	Mt. Vernon Ave. / Project Dwy. 2	<u>CSS</u>	0	1	0	0	2	0	0	0	0	0	0	<u>1</u>	10.3	11.1	B	B
7	Project Dwy. 3 / Center St.	<u>CSS</u>	0	0	0	0	0	<u>1</u>	0	1	0	0	1	0	9.5	8.9	A	A
8	Project Dwy. 4 / Center St.	<u>CSS</u>	0	0	0	0	<u>1!</u>	0	0.5	0.5	0	0	1	0	9.5	8.9	A	A

<sup>1</sup> TS = Traffic Signal; AWS = All Way Stop; CSS = Cross Street Stop

<sup>2</sup> When a right turn is designated, the lane can either be striped or unstriped. To function as a right turn lane there must be sufficient width for right turning vehicles to travel outside the through lanes.

L = Left; T = Through; R = Right; 1! = Shared Left-Through-Right Lane; 0.5 = Shared Lane; d = Defacto right turn lane; 1 = Improvement

<sup>3</sup> Delay and level of service calculated using the following analysis software: Synchro 10 HCM6

**TABLE 5-3**  
**INTERSECTION ANALYSIS FOR**  
**EXISTING PLUS AMBIENT PLUS PROJECT PLUS CUMULATIVE (2022) CONDITIONS**

ID	Intersection	Traffic Control <sup>1</sup>	Intersection Approach Lanes <sup>2</sup>												Delay <sup>3</sup> (secs.)		Level of Service <sup>3</sup>	
			Northbound			Southbound			Eastbound			Westbound			AM	PM	AM	PM
			L	T	R	L	T	R	L	T	R	L	T	R				
1	Mt. Vernon Ave. / Center St.	TS	1	1	1	1	2	0	1	2	0	1	2	0	20.8	28.7	C	C
2	Michigan Ave. / Center St.	AWS	0.5	0.5	d	0.5	0.5	d	0.5	1.5	d	0.5	1.5	d	9.4	10.4	A	B
3	Mt. Vernon Ave. / Main St. - With Improvements	AWS	0.5	0.5	d	0.5	1.5	d	0.5	0.5	d	0	1!	0	13.2	38.1	B	E
		AWS	0.5	<u>1.5</u>	0	0.5	1.5	d	0.5	0.5	d	0	1!	0	10.8	17.1	B	C
4	Mt. Vernon Ave. / Spring St.	TS	1	2	0	1	1	1	1	1	0	1	1	0	17.7	20.6	B	C
5	Mt. Vernon Ave. / Project Dwy. 1	<u>CSS</u>	0	1	0	0.5	1.5	0	0	0	0	0	<u>1!</u>	0	12.5	16.0	B	C
6	Mt. Vernon Ave. / Project Dwy. 2	<u>CSS</u>	0	1	0	0	2	0	0	0	0	0	0	<u>1</u>	10.4	11.5	B	B
7	Project Dwy. 3 / Center St.	<u>CSS</u>	0	0	0	0	0	<u>1</u>	0	1	0	0	1	0	9.6	9.0	A	A
8	Project Dwy. 4 / Center St.	<u>CSS</u>	0	0	0	0	<u>1!</u>	0	0.5	0.5	0	0	1	0	9.5	9.0	A	A

<sup>1</sup> TS = Traffic Signal; CSS = Cross Street Stop

<sup>2</sup> When a right turn is designated, the lane can either be striped or unstriped. To function as a right turn lane there must be sufficient width for right turning vehicles to travel outside the through lanes.

L = Left; T = Through; R = Right; 1! = Shared Left-Through-Right Lane; 0.5 = Shared Lane; d = Defacto right turn lane; 1 = Improvement

<sup>3</sup> Delay and level of service calculated using the following analysis software: Synchro 10 HCM6

THIS PAGE IS LEFT INTENTIONALLY BLANK

## 6.0 FINDINGS AND RECOMMENDATIONS

---

### A. Traffic Impacts and Level of Service Intersections Analysis

For Existing (2020) and E+P traffic conditions, the study area intersections are operating at an acceptable level of service during the peak hours with existing geometry. For E+A+P and E+A+P+C conditions, additional improvements are recommended to address potential deficiencies.

### B. Recommended Off-Site Improvements

#### **Existing + Ambient + Project + Cumulative Conditions**

The northbound striping at the intersection of Mt. Vernon Ave. / Main St. will be re-striped to provide a 2<sup>nd</sup> through lane (see Figure 6-A). This improvement will allow this location to operate at acceptable levels of service during the peak hours.

#### Funding Mechanisms

In order to address the cumulate traffic impacts from the proposed project and other developments in the area, the County has the following funding mechanisms available.

#### **Transportation Uniform Mitigation Fee (TUMF)**

The Transportation Uniform Mitigation Fee (TUMF) Program was established to assist in funding the Regional System of Highways and Arterials throughout Riverside County. TUMF allows developers to contribute toward sustaining the regional transportation system on a “fair share” basis. Managed by the Western Riverside Council of Governments (WRCOG), the program is not designed to be the only source of revenue but would complement funds generated by Measure A, local transportation fee programs, etc.

#### **Development Impact Fees (DIF)**

The development impact fee (DIF) is intended to construct or acquire needed facilities, preserve open space, and habitat needed to serve new developments. The transportation facilities include roads, bridges, and traffic signals.

### C. Circulation Recommendations

#### On-Site

Construction of on-site improvements shall occur in conjunction with adjacent project development activity or as needed for project access purposes.

# FIGURE 6-A MT. VERNON AVENUE/MAIN STREET CONCEPTUAL STRIPING PLAN

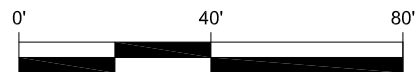
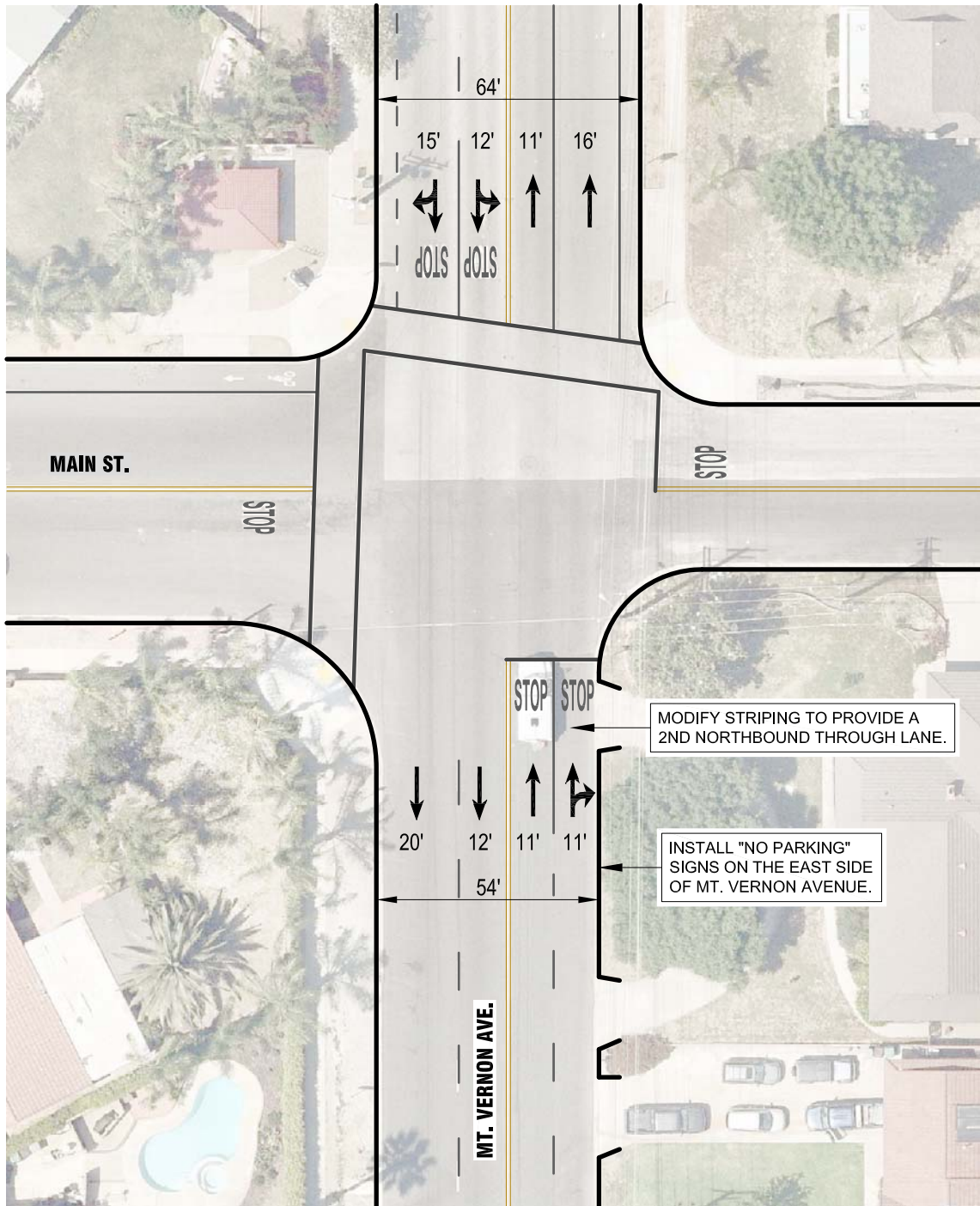

The recommended on-site roadway improvements are described below and shown on Figure 6-B.

- Adjacent to the Project site, construct Mt. Vernon Avenue to its ultimate half-section width as a secondary roadway from Project's northerly boundary to Center Street.
- Restrict Driveway 2 to right-in/right-out only driveway by providing a 4 ft. wide raised median along Mt. Vernon Avenue.
- Restrict Driveway 3 to right-in/right-out only driveway by providing a 4 ft. wide raised median along Center Street.
- Provide stop sign control at the project driveways
- On-site traffic signing and striping should be implemented in conjunction with detailed construction plans for the project.
- Verify that minimum sight distance is provided at the project driveways.

# FIGURE 6-B ON-SITE CIRCULATION RECOMMENDATIONS

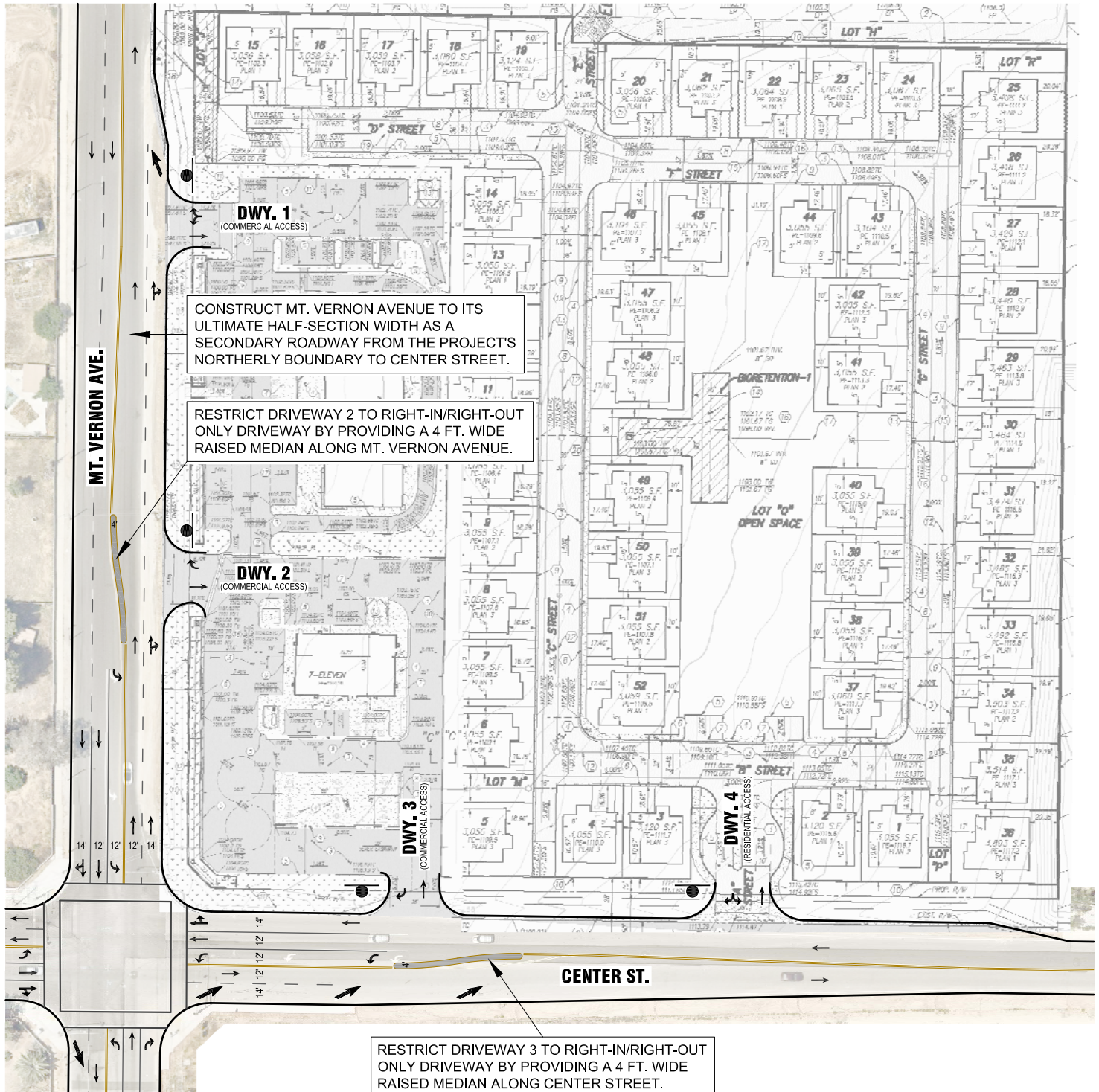

ON-SITE TRAFFIC SIGNING AND STRIPING SHOULD BE IMPLEMENTED IN CONJUNCTION WITH DETAILED CONSTRUCTION PLANS FOR THE PROJECT.

VERIFY THAT MINIMUM SIGHT DISTANCE IS PROVIDED AT THE PROJECT DRIVEWAYS.

PROVIDE STOP SIGN CONTROLS AT PROJECT DRIVEWAYS.

**LEGEND:**  
● = STOP SIGN

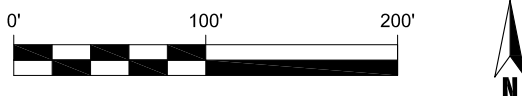

**APPENDIX A**

**SCOPING AGREEMENT**

THIS PAGE IS LEFT INTENTIONALLY BLANK

## SCOPING AGREEMENT FOR TRAFFIC IMPACT STUDY

This letter acknowledges the Riverside County Transportation Department requirements for traffic impact analysis of the following project. The analysis must follow the latest version of the Riverside County Transportation Department Traffic Study Guidelines.

Case No. TTM37743

Related Cases - \_\_\_\_\_

SP No. \_\_\_\_\_

EIR No. \_\_\_\_\_

GPA No. \_\_\_\_\_

CZ No. \_\_\_\_\_

Project Name: TTM 37743/TPM 37859 - Highgrove

Project Address: North of Center St. and east of Mt. Vernon Ave.

Project Description: Retail (8,380 sf), a C-Store w/12 vehicle positions, and 52 SFDU

	<u>Consultant</u>	<u>Developer</u>
Name:	<u>Scott Sato</u>	<u>Mr. Steven Berzansky</u>
Address:	<u>Trames Solutions, Inc.</u>	<u>Highgrove Inv, LLC.</u>
	<u>4225 Oceanside Blvd., #354H</u>	<u>7111 Indiana Ave., STE. 300</u>
	<u>Oceanside, CA 92056</u>	<u>Riverside, CA 92504</u>
Phone No:	<u>(760) 291-1400</u>	
Date:	<u>2/28/2020</u>	

**A. Trip Generation Source:** \_\_\_\_\_ ITE 10th Edition (See Tables 1 & 2)

Current GP Land Use: <u>MDR</u>	Proposed Land Use: <u>Parcel A-CR, Parcel B-PDR</u>
Current Zoning: <u>R-1</u>	Proposed Zoning: <u>Parcel A-C-P-S, Parcel B-R-1</u>

	Current Trip Generation			Proposed Trip Generation		
	<u>In</u>	<u>Out</u>	<u>Total</u>	<u>In</u>	<u>Out</u>	<u>Total</u>
AM Trips	<u>-</u>	<u>-</u>	<u>-</u>	<u>60</u>	<u>77</u>	<u>136</u>
PM Trips	<u>-</u>	<u>-</u>	<u>-</u>	<u>90</u>	<u>79</u>	<u>169</u>
Internal Trip Allowance	<u>No</u>		( <u>0</u> % Trip Discount)			
Pass-By Trip Allowance	<u>Yes</u>		( <u>Varies</u> % Trip Discount)			

A passby trip discount of 25% is allowed for appropriate land uses. The passby trips at adjacent study area intersections and project driveways shall be indicated on a report figure.

**B. Trip Geographic Distribution:** (See attached exhibit for detailed assignment).

N 25%                      S 20%                      E 5%                      W 50%

**C. Background Traffic**

Project Build-out Year 2022                      Annual Ambient Growth Rate: 2.0 %

Phase Years \_\_\_\_\_

Other projects to be analyzed: \_\_\_\_\_

Model/Forecast methodology: \_\_\_\_\_

**D. Study Intersections:** (NOTE: Subject to revision after other projects, trip generation and distribution are determined, or comments form other agencies).

- |   |   |
|---|---|
| <p>1 <u>Mt. Vernon/Center St.</u></p> <p>2 <u>Michigan Ave./Center St.</u></p> <p>3 <u>Mt. Vernon/Main St.</u></p> <p>4 <u>Mt. Vernon/Spring St.</u></p> <p>5 <u>Project Dwy. 1/Mt. Vernon Ave.</u></p> | <p>6 <u>Project Dwy. 2/Mt. Vernon Ave.</u></p> <p>7 <u>Project Dwy. 3/Center St.</u></p> <p>8 <u>Project Dwy. 4/Center St.</u></p> <p>9 _____</p> <p>10 _____</p> |
|---|---|

**E. Study Roadway Segments:**

1 \_\_\_\_\_  
2 \_\_\_\_\_

3 \_\_\_\_\_  
4 \_\_\_\_\_

**F. Other Jurisdictional Impacts**

Is this project within a City's Sphere of influence or one mile radius of City boundaries?

**Yes**

If so, name of City jurisdiction: Grand Terrace

**G. Site Plan**

**H. Specific issues to be addressed in the Study (in addition to the standard analysis described in the Guideline) (To be filled out by Transportation Department)**

- Existing
- Existing+Project
- Existing+Ambient Growth+Project
- Existing+Ambient Growth+Project +Cumulative

**I. Existing Conditions**

Traffic count data must be new or recent. Provide traffic count dates if using other than new counts.

Traffic counts may only be conducted after school resumes.

**Date of Counts**

Recommended by:

\_\_\_\_\_  
2/28/2020  
Consultant's Representative      Date

Consultant Signature

Approved By:

K. [Signature]  
Riverside County Transportation Department      03/26/2020  
Date

Scoping Agreement Subitted on \_\_\_\_\_  
Revised On \_\_\_\_\_

**TABLE 1  
PROJECT TRIP GENERATION RATES<sup>1</sup>**

Land Use	ITE Code	Quantity <sup>2</sup>	Peak Hour Trip Rates						Daily
			AM			PM			
			IN	OUT	Total	IN	OUT	Total	
Single Fam. Detached	210	52 DU	0.19	0.56	0.75	0.62	0.37	0.99	9.44
Convenience Mkt. w/Pumps	853	12 VFP	10.38	10.38	20.76	11.52	11.52	23.04	322.50
Shopping Center	820	8.38 TSF	0.58	0.36	0.94	1.83	1.98	3.81	37.75

<sup>1</sup> Trip Generation Source: Institute of Transportation Engineers (ITE), Trip Generation Manual, 10th Edition (2017).

<sup>2</sup> VFP = Vehicle Fueling Positions; TSF = Thousand Square Feet; DU = Dwelling Units

**TABLE 2  
PROJECT TRIP GENERATION SUMMARY**

Land Use	ITE Code	Quantity <sup>1</sup>	Peak Hour						Daily
			AM			PM			
			In	Out	Total	In	Out	Total	
Single Fam. Detached	210	52 DU	10	29	39	32	19	51	491
Convenience Mkt. w/Pumps	853	12 VFP	125	125	250	138	138	276	3,870
- Pass-By Reduction (AM-63%, PM-66%)			-79	-79	-158	-91	-91	-182	-2,438
Shopping Center	820	8.38 TSF	5	3	8	15	17	32	316
- Pass-By Reduction (25%)			-2	-2	-3	-4	-4	-8	-79
<b>TOTAL EXTERNAL TRIPS</b>			<b>60</b>	<b>77</b>	<b>136</b>	<b>90</b>	<b>79</b>	<b>169</b>	<b>2,160</b>

<sup>1</sup> VFP = Vehicle Fueling Positions; TSF = Thousand Square Feet; DU = Dwelling Units

# FIGURE A STUDY AREA

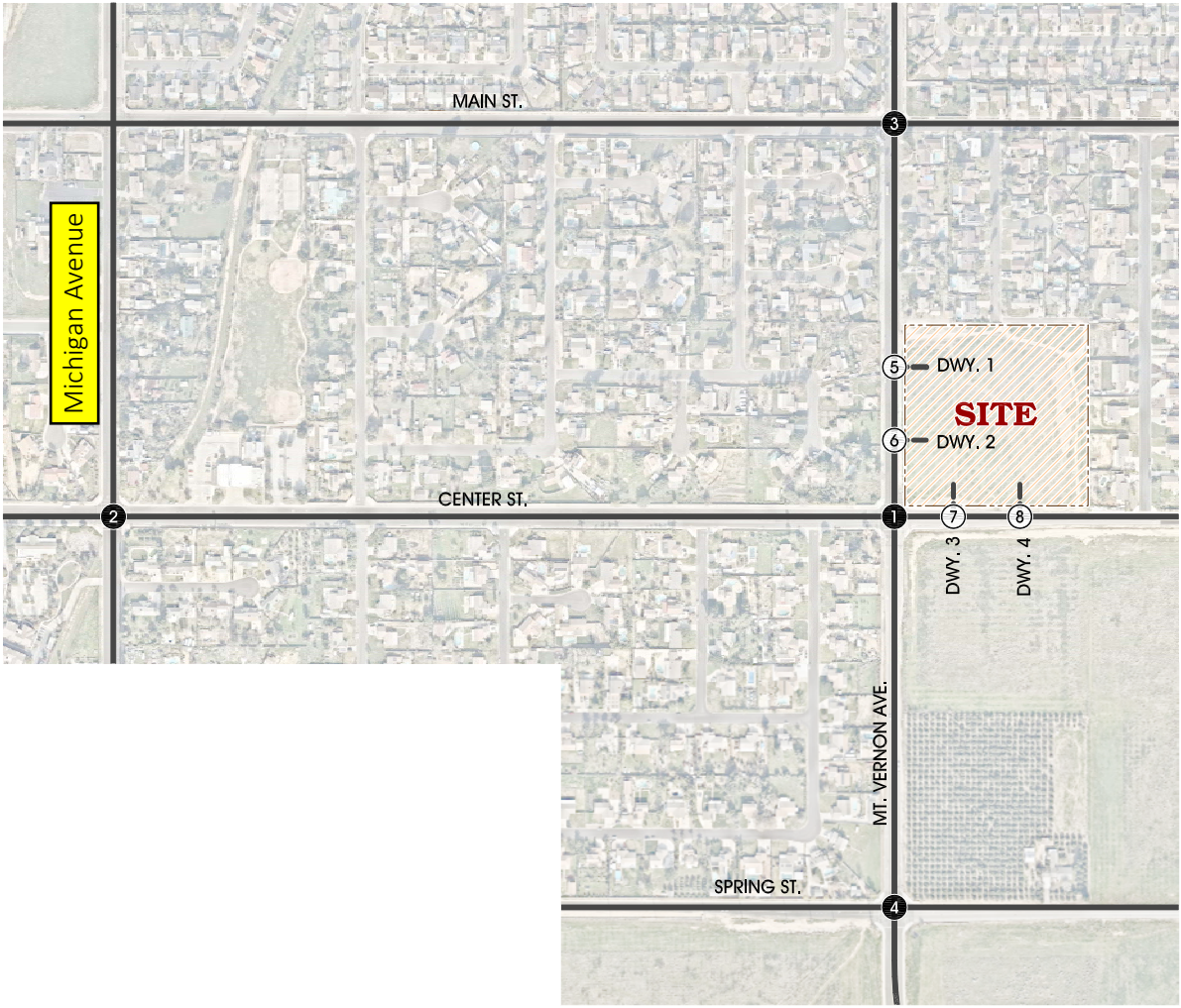

**LEGEND:**

- ④ = EXISTING INTERSECTION ANALYSIS LOCATION
- ④ = FUTURE INTERSECTION ANALYSIS LOCATION
- = FUTURE ROADWAY / PROJECT DRIVEWAY



# FIGURE B SITE PLAN

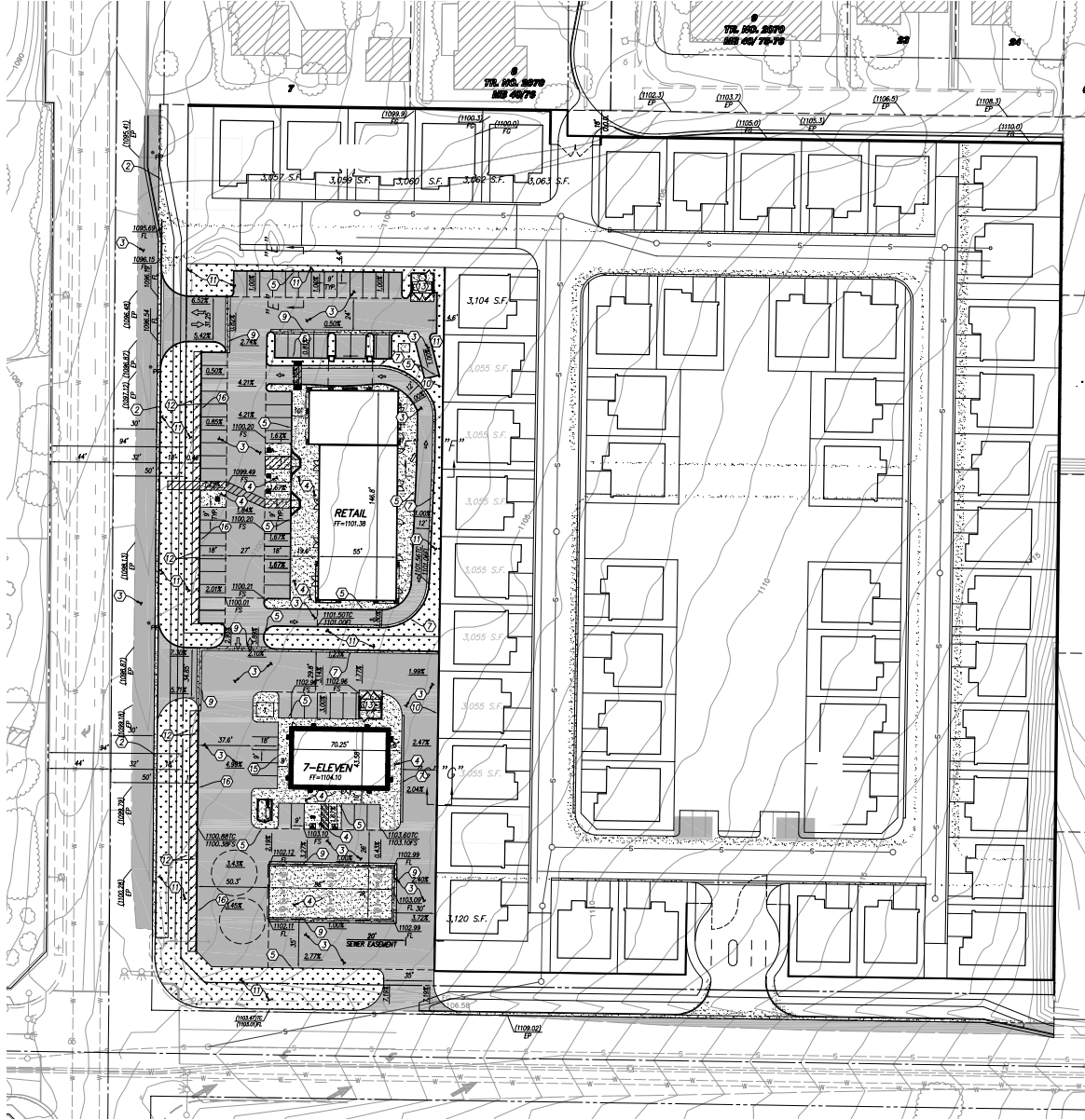

# FIGURE C PROJECT TRIP DISTRIBUTION

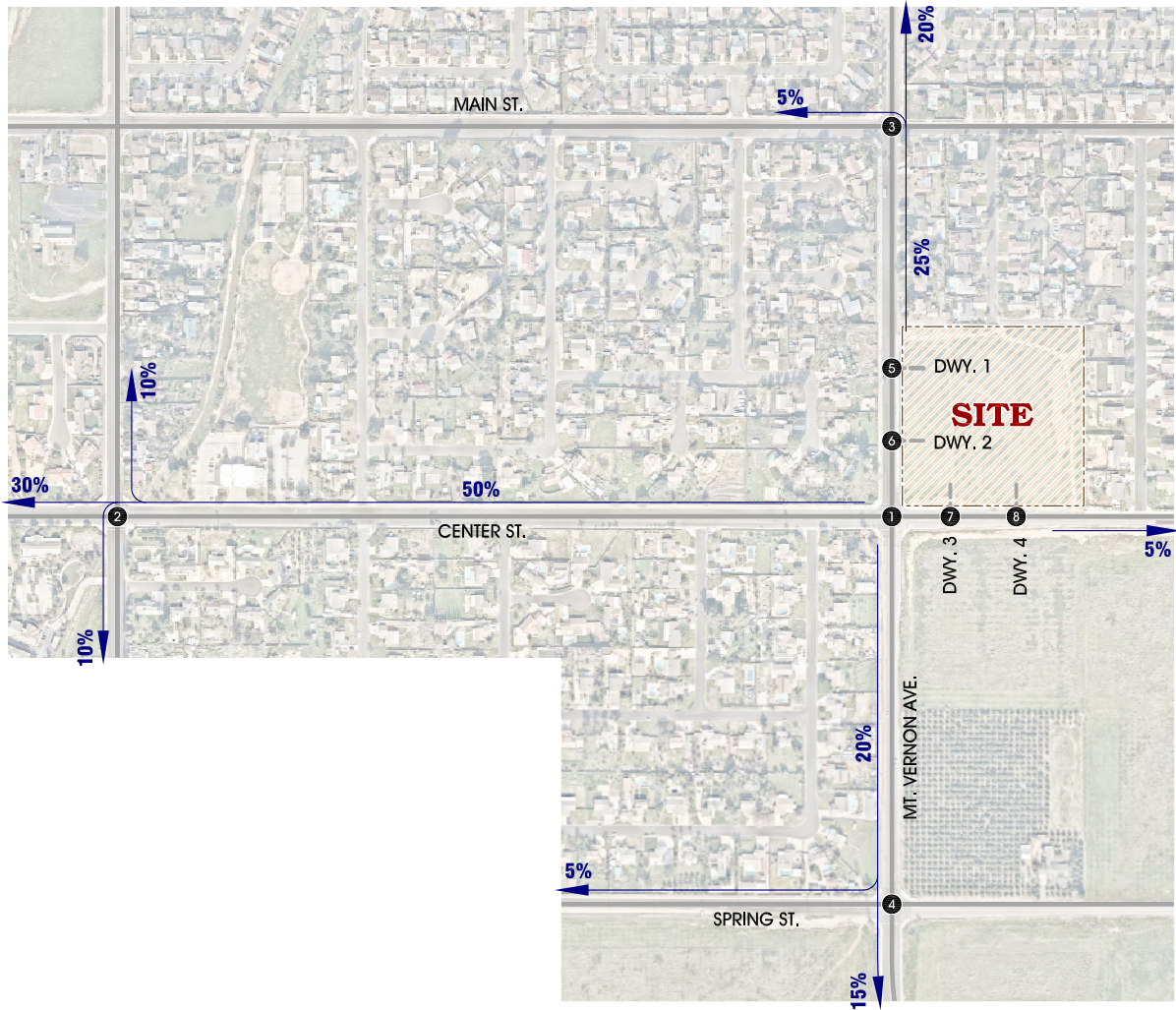

**LEGEND:**

- ③ = INTERSECTION ID
- 10% = PERCENT TO / FROM PROJECT



**APPENDIX B**

**TRAFFIC COUNT WORKSHEETS**

THIS PAGE IS LEFT INTENTIONALLY BLANK

City of Colton  
 N/S: South La Cadena Drive  
 E/W: Barton Road  
 Weather: Clear

File Name : 01\_COL\_La Cadena\_Barton AM  
 Site Code : 20120202  
 Start Date : 4/16/2020  
 Page No : 1

Groups Printed- Total Volume

Start Time	South La Cadena Drive Southbound			Barton Road Westbound			South La Cadena Drive Northbound			Int. Total
	Left	Thru	App. Total	Left	Right	App. Total	Thru	Right	App. Total	
07:00 AM	13	71	84	12	7	19	44	18	62	165
07:15 AM	14	76	90	13	16	29	57	10	67	186
07:30 AM	18	108	126	12	13	25	53	10	63	214
07:45 AM	20	101	121	8	13	21	66	15	81	223
Total	65	356	421	45	49	94	220	53	273	788
08:00 AM	8	69	77	3	16	19	43	12	55	151
08:15 AM	23	83	106	6	14	20	37	14	51	177
08:30 AM	14	65	79	14	13	27	48	6	54	160
08:45 AM	15	67	82	15	13	28	51	10	61	171
Total	60	284	344	38	56	94	179	42	221	659
Grand Total	125	640	765	83	105	188	399	95	494	1447
Apprch %	16.3	83.7		44.1	55.9		80.8	19.2		
Total %	8.6	44.2	52.9	5.7	7.3	13	27.6	6.6	34.1	

Start Time	South La Cadena Drive Southbound			Barton Road Westbound			South La Cadena Drive Northbound			Int. Total
	Left	Thru	App. Total	Left	Right	App. Total	Thru	Right	App. Total	
07:00 AM	13	71	84	12	7	19	44	<b>18</b>	62	165
07:15 AM	14	76	90	<b>13</b>	<b>16</b>	<b>29</b>	57	10	67	186
07:30 AM	18	<b>108</b>	<b>126</b>	12	13	25	53	10	63	214
07:45 AM	<b>20</b>	101	121	8	13	21	<b>66</b>	15	<b>81</b>	<b>223</b>
Total Volume	65	356	421	45	49	94	220	53	273	788
% App. Total	15.4	84.6		47.9	52.1		80.6	19.4		
PHF	.813	.824	.835	.865	.766	.810	.833	.736	.843	.883

Peak Hour Analysis From 07:00 AM to 08:45 AM - Peak 1 of 1  
 Peak Hour for Entire Intersection Begins at 07:00 AM

City of Colton  
 N/S: South La Cadena Drive  
 E/W: Barton Road  
 Weather: Clear

File Name : 01\_COL\_La Cadena\_Barton AM  
 Site Code : 20120202  
 Start Date : 4/16/2020  
 Page No : 2

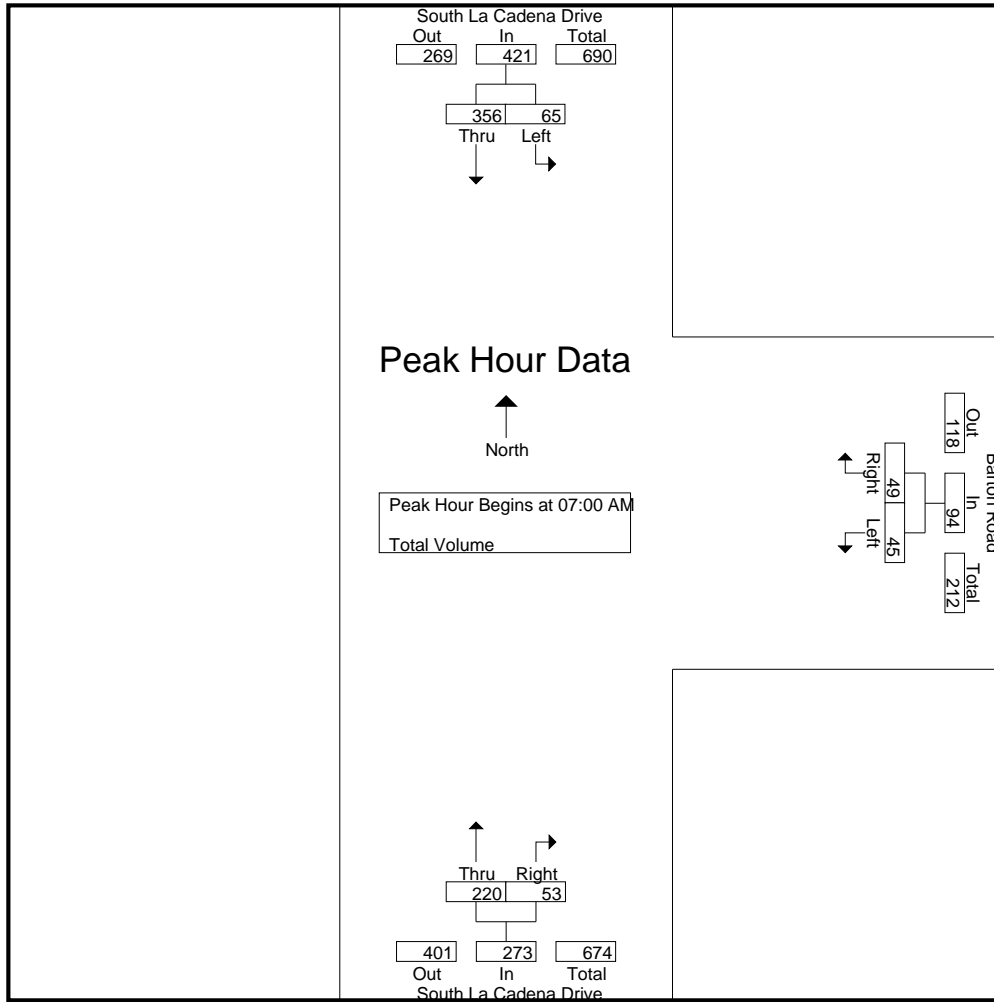

Peak Hour Analysis From 07:00 AM to 08:45 AM - Peak 1 of 1  
 Peak Hour for Each Approach Begins at:

	07:30 AM			07:00 AM			07:00 AM		
+0 mins.	18	<b>108</b>	<b>126</b>	12	7	19	44	<b>18</b>	62
+15 mins.	20	101	121	<b>13</b>	<b>16</b>	<b>29</b>	57	10	67
+30 mins.	8	69	77	12	13	25	53	10	63
+45 mins.	<b>23</b>	83	106	8	13	21	<b>66</b>	15	<b>81</b>
Total Volume	69	361	430	45	49	94	220	53	273
% App. Total	16	84		47.9	52.1		80.6	19.4	
PHF	.750	.836	.853	.865	.766	.810	.833	.736	.843

City of Colton  
 N/S: South La Cadena Drive  
 E/W: Barton Road  
 Weather: Clear

File Name : 01\_COL\_La Cadena\_Barton PM  
 Site Code : 20120202  
 Start Date : 4/16/2020  
 Page No : 1

Groups Printed- Total Volume

Start Time	South La Cadena Drive Southbound			Barton Road Westbound			South La Cadena Drive Northbound			Int. Total
	Left	Thru	App. Total	Left	Right	App. Total	Thru	Right	App. Total	
04:00 PM	35	99	134	29	33	62	97	19	116	312
04:15 PM	33	94	127	26	20	46	104	28	132	305
04:30 PM	22	108	130	25	34	59	77	13	90	279
04:45 PM	36	91	127	24	20	44	78	11	89	260
Total	126	392	518	104	107	211	356	71	427	1156
05:00 PM	28	103	131	25	24	49	85	15	100	280
05:15 PM	32	97	129	29	26	55	86	10	96	280
05:30 PM	29	90	119	15	25	40	71	15	86	245
05:45 PM	25	70	95	19	20	39	73	17	90	224
Total	114	360	474	88	95	183	315	57	372	1029
Grand Total	240	752	992	192	202	394	671	128	799	2185
Apprch %	24.2	75.8		48.7	51.3		84	16		
Total %	11	34.4	45.4	8.8	9.2	18	30.7	5.9	36.6	

Start Time	South La Cadena Drive Southbound			Barton Road Westbound			South La Cadena Drive Northbound			Int. Total
	Left	Thru	App. Total	Left	Right	App. Total	Thru	Right	App. Total	
04:00 PM	35	99	<b>134</b>	<b>29</b>	33	<b>62</b>	97	19	116	<b>312</b>
04:15 PM	33	94	127	26	20	46	<b>104</b>	<b>28</b>	<b>132</b>	305
04:30 PM	22	<b>108</b>	130	25	<b>34</b>	59	77	13	90	279
04:45 PM	<b>36</b>	91	127	24	20	44	78	11	89	260
Total Volume	126	392	518	104	107	211	356	71	427	1156
% App. Total	24.3	75.7		49.3	50.7		83.4	16.6		
PHF	.875	.907	.966	.897	.787	.851	.856	.634	.809	.926

Peak Hour Analysis From 04:00 PM to 05:45 PM - Peak 1 of 1  
 Peak Hour for Entire Intersection Begins at 04:00 PM

City of Colton  
 N/S: South La Cadena Drive  
 E/W: Barton Road  
 Weather: Clear

File Name : 01\_COL\_La Cadena\_Barton PM  
 Site Code : 20120202  
 Start Date : 4/16/2020  
 Page No : 2

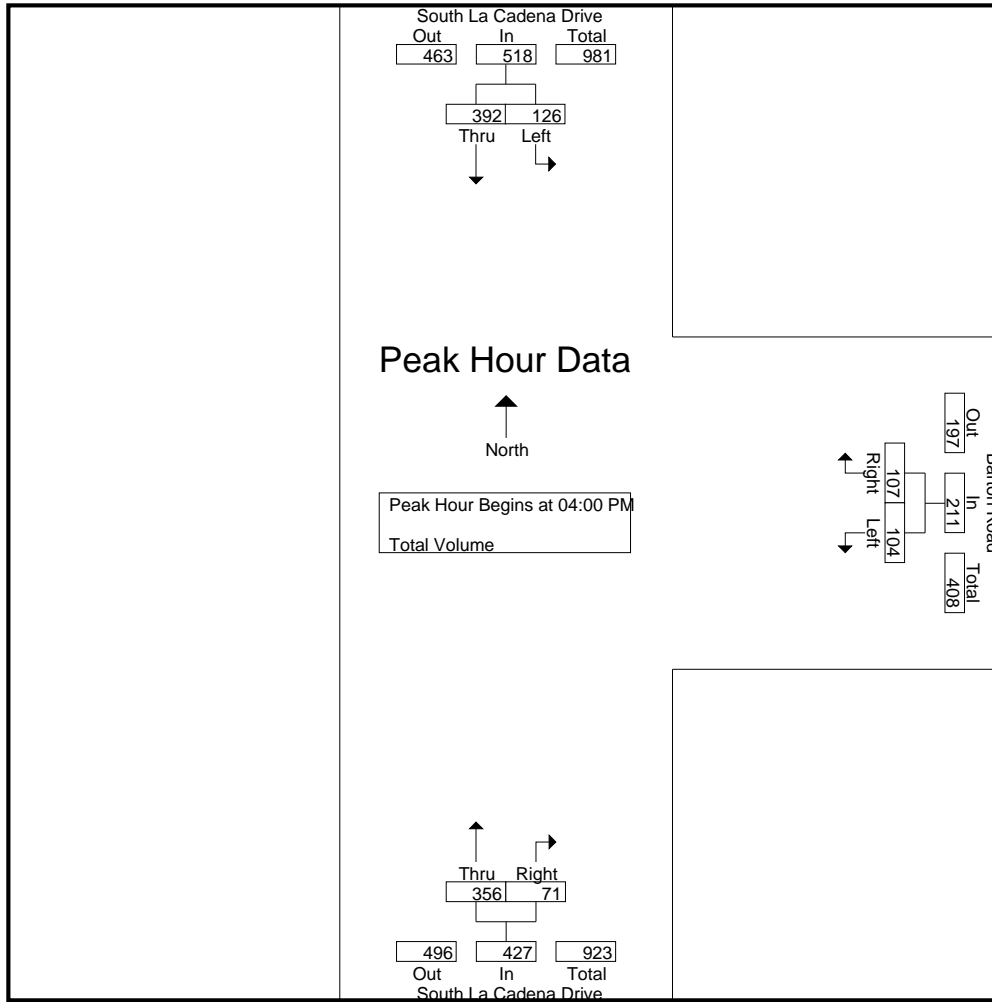

Peak Hour Analysis From 04:00 PM to 05:45 PM - Peak 1 of 1  
 Peak Hour for Each Approach Begins at:

	04:00 PM			04:00 PM			04:00 PM		
+0 mins.	35	99	<b>134</b>	<b>29</b>	33	<b>62</b>	97	19	116
+15 mins.	33	94	127	26	20	46	<b>104</b>	<b>28</b>	<b>132</b>
+30 mins.	22	<b>108</b>	130	25	<b>34</b>	59	77	13	90
+45 mins.	<b>36</b>	91	127	24	20	44	78	11	89
Total Volume	126	392	518	104	107	211	356	71	427
% App. Total	24.3	75.7		49.3	50.7		83.4	16.6	
PHF	.875	.907	.966	.897	.787	.851	.856	.634	.809

County of Riverside  
 N/S: Highgrove Place  
 E/W: Center Street  
 Weather: Clear

File Name : 02\_CRV\_Highgrove PI\_Center AM  
 Site Code : 20120202  
 Start Date : 4/16/2020  
 Page No : 1

Groups Printed- Total Volume

Start Time	Highgrove Place Southbound				Center Street Westbound				Highgrove Place Northbound				Center Street Eastbound				Int. Total
	Left	Thru	Right	App. Total	Left	Thru	Right	App. Total	Left	Thru	Right	App. Total	Left	Thru	Right	App. Total	
07:00 AM	1	0	1	2	1	45	1	47	8	0	25	33	0	25	1	26	108
07:15 AM	0	0	9	9	2	57	0	59	14	0	15	29	0	21	3	24	121
07:30 AM	0	0	2	2	0	52	1	53	14	0	23	37	0	32	1	33	125
07:45 AM	0	0	7	7	1	50	1	52	15	1	34	50	1	33	4	38	147
Total	1	0	19	20	4	204	3	211	51	1	97	149	1	111	9	121	501
08:00 AM	1	0	1	2	1	43	0	44	12	0	26	38	1	23	3	27	111
08:15 AM	3	0	2	5	0	54	0	54	18	0	23	41	0	19	0	19	119
08:30 AM	1	1	3	5	1	54	0	55	11	0	16	27	0	25	3	28	115
08:45 AM	0	0	1	1	1	43	3	47	22	0	22	44	0	20	2	22	114
Total	5	1	7	13	3	194	3	200	63	0	87	150	1	87	8	96	459
Grand Total	6	1	26	33	7	398	6	411	114	1	184	299	2	198	17	217	960
Apprch %	18.2	3	78.8		1.7	96.8	1.5		38.1	0.3	61.5		0.9	91.2	7.8		
Total %	0.6	0.1	2.7	3.4	0.7	41.5	0.6	42.8	11.9	0.1	19.2	31.1	0.2	20.6	1.8	22.6	

Start Time	Highgrove Place Southbound				Center Street Westbound				Highgrove Place Northbound				Center Street Eastbound				Int. Total
	Left	Thru	Right	App. Total	Left	Thru	Right	App. Total	Left	Thru	Right	App. Total	Left	Thru	Right	App. Total	
Peak Hour Analysis From 07:00 AM to 08:45 AM - Peak 1 of 1																	
Peak Hour for Entire Intersection Begins at 07:15 AM																	
07:15 AM	0	0	9	9	2	57	0	59	14	0	15	29	0	21	3	24	121
07:30 AM	0	0	2	2	0	52	1	53	14	0	23	37	0	32	1	33	125
07:45 AM	0	0	7	7	1	50	1	52	15	1	34	50	1	33	4	38	147
08:00 AM	1	0	1	2	1	43	0	44	12	0	26	38	1	23	3	27	111
Total Volume	1	0	19	20	4	202	2	208	55	1	98	154	2	109	11	122	504
% App. Total	5	0	95		1.9	97.1	1		35.7	0.6	63.6		1.6	89.3	9		
PHF	.250	.000	.528	.556	.500	.886	.500	.881	.917	.250	.721	.770	.500	.826	.688	.803	.857

County of Riverside  
 N/S: Highgrove Place  
 E/W: Center Street  
 Weather: Clear

File Name : 02\_CRV\_Highgrove PI\_Center AM  
 Site Code : 20120202  
 Start Date : 4/16/2020  
 Page No : 2

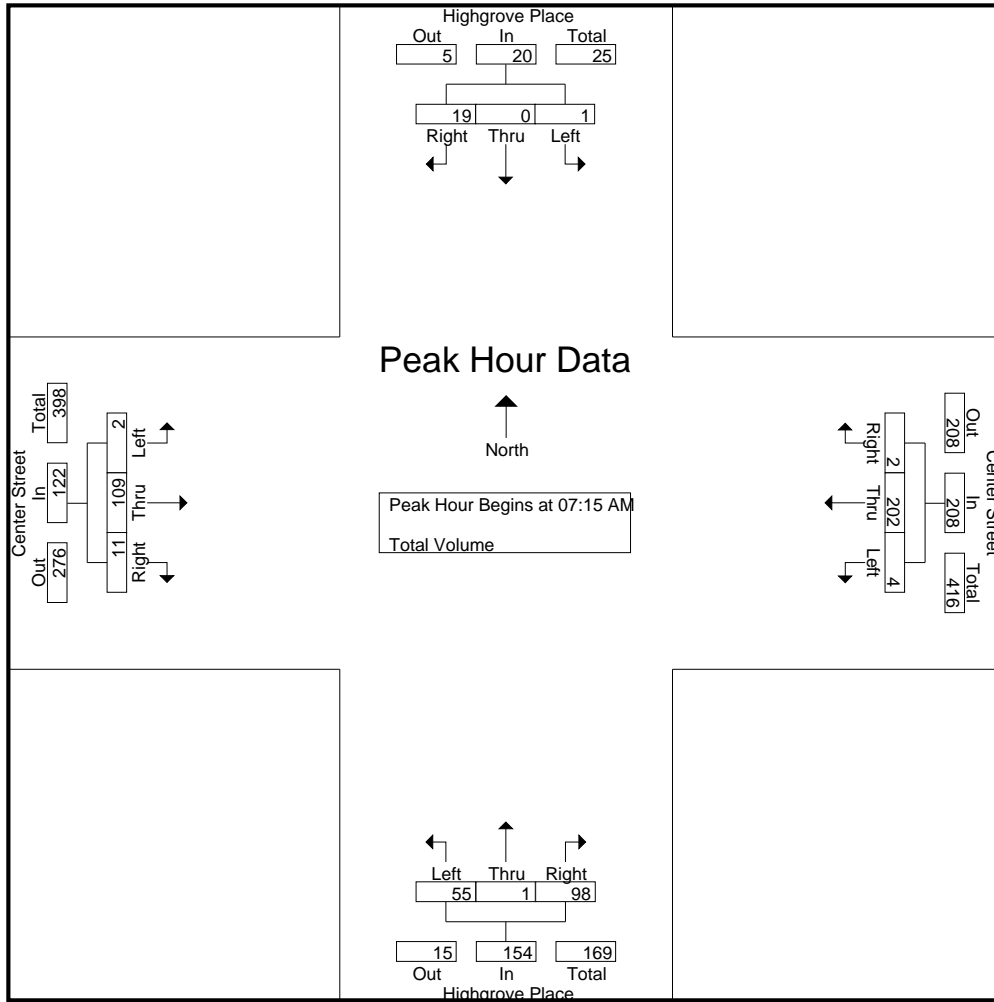

Peak Hour Analysis From 07:00 AM to 08:45 AM - Peak 1 of 1  
 Peak Hour for Each Approach Begins at:

	07:00 AM				07:30 AM				07:15 AM							
+0 mins.	1	0	1	2	1	45	1	47	14	0	23	37	0	21	3	24
+15 mins.	0	0	9	9	2	57	0	59	15	1	34	50	0	32	1	33
+30 mins.	0	0	2	2	0	52	1	53	12	0	26	38	1	33	4	38
+45 mins.	0	0	7	7	1	50	1	52	18	0	23	41	1	23	3	27
Total Volume	1	0	19	20	4	204	3	211	59	1	106	166	2	109	11	122
% App. Total	5	0	95		1.9	96.7	1.4		35.5	0.6	63.9		1.6	89.3	9	
PHF	.250	.000	.528	.556	.500	.895	.750	.894	.819	.250	.779	.830	.500	.826	.688	.803

County of Riverside  
 N/S: Highgrove Place  
 E/W: Center Street  
 Weather: Clear

File Name : 02\_CRV\_Highgrove PI\_Center PM  
 Site Code : 20120202  
 Start Date : 4/16/2020  
 Page No : 1

Groups Printed- Total Volume

Start Time	Highgrove Place Southbound				Center Street Westbound				Highgrove Place Northbound				Center Street Eastbound				Int. Total
	Left	Thru	Right	App. Total	Left	Thru	Right	App. Total	Left	Thru	Right	App. Total	Left	Thru	Right	App. Total	
04:00 PM	2	0	14	16	0	63	0	63	26	0	50	76	0	55	1	56	211
04:15 PM	1	0	4	5	0	58	0	58	16	0	42	58	1	49	4	54	175
04:30 PM	0	0	10	10	1	65	1	67	20	0	60	80	1	41	5	47	204
04:45 PM	2	0	9	11	1	51	1	53	17	0	40	57	2	47	2	51	172
Total	5	0	37	42	2	237	2	241	79	0	192	271	4	192	12	208	762
05:00 PM	0	0	7	7	0	34	0	34	20	0	49	69	2	40	5	47	157
05:15 PM	0	0	6	6	0	57	1	58	14	2	45	61	0	44	1	45	170
05:30 PM	1	0	7	8	1	37	2	40	11	1	48	60	1	39	2	42	150
05:45 PM	0	0	3	3	0	55	1	56	10	0	31	41	0	37	2	39	139
Total	1	0	23	24	1	183	4	188	55	3	173	231	3	160	10	173	616
Grand Total	6	0	60	66	3	420	6	429	134	3	365	502	7	352	22	381	1378
Apprch %	9.1	0	90.9		0.7	97.9	1.4		26.7	0.6	72.7		1.8	92.4	5.8		
Total %	0.4	0	4.4	4.8	0.2	30.5	0.4	31.1	9.7	0.2	26.5	36.4	0.5	25.5	1.6	27.6	

Start Time	Highgrove Place Southbound				Center Street Westbound				Highgrove Place Northbound				Center Street Eastbound				Int. Total
	Left	Thru	Right	App. Total	Left	Thru	Right	App. Total	Left	Thru	Right	App. Total	Left	Thru	Right	App. Total	
Peak Hour Analysis From 04:00 PM to 05:45 PM - Peak 1 of 1																	
Peak Hour for Entire Intersection Begins at 04:00 PM																	
04:00 PM	2	0	14	16	0	63	0	63	26	0	50	76	0	55	1	56	211
04:15 PM	1	0	4	5	0	58	0	58	16	0	42	58	1	49	4	54	175
04:30 PM	0	0	10	10	1	65	1	67	20	0	60	80	1	41	5	47	204
04:45 PM	2	0	9	11	1	51	1	53	17	0	40	57	2	47	2	51	172
Total Volume	5	0	37	42	2	237	2	241	79	0	192	271	4	192	12	208	762
% App. Total	11.9	0	88.1		0.8	98.3	0.8		29.2	0	70.8		1.9	92.3	5.8		
PHF	.625	.000	.661	.656	.500	.912	.500	.899	.760	.000	.800	.847	.500	.873	.600	.929	.903

County of Riverside  
 N/S: Highgrove Place  
 E/W: Center Street  
 Weather: Clear

File Name : 02\_CRV\_Highgrove PI\_Center PM  
 Site Code : 20120202  
 Start Date : 4/16/2020  
 Page No : 2

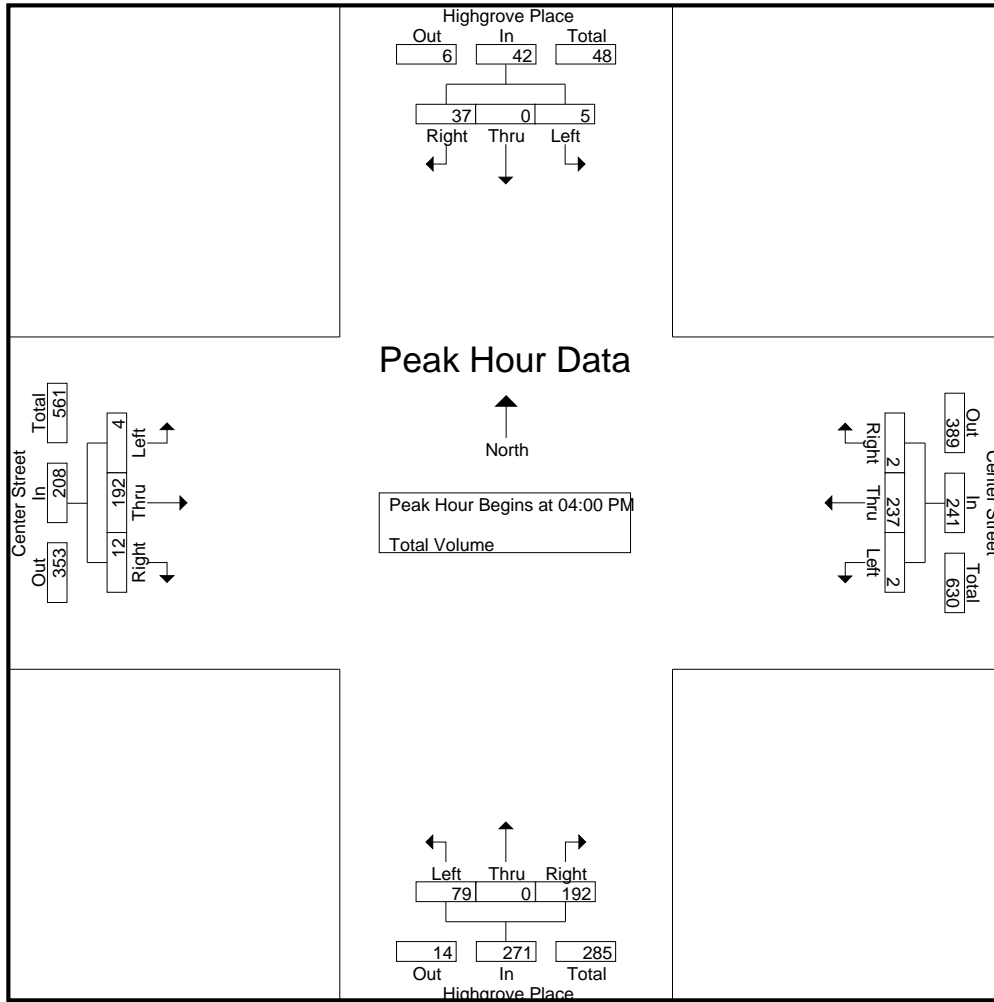

Peak Hour Analysis From 04:00 PM to 05:45 PM - Peak 1 of 1  
 Peak Hour for Each Approach Begins at:

	04:00 PM				04:00 PM				04:00 PM				04:00 PM			
+0 mins.	2	0	14	16	0	63	0	63	26	0	50	76	0	55	1	56
+15 mins.	1	0	4	5	0	58	0	58	16	0	42	58	1	49	4	54
+30 mins.	0	0	10	10	1	65	1	67	20	0	60	80	1	41	5	47
+45 mins.	2	0	9	11	1	51	1	53	17	0	40	57	2	47	2	51
Total Volume	5	0	37	42	2	237	2	241	79	0	192	271	4	192	12	208
% App. Total	11.9	0	88.1		0.8	98.3	0.8		29.2	0	70.8		1.9	92.3	5.8	
PHF	.625	.000	.661	.656	.500	.912	.500	.899	.760	.000	.800	.847	.500	.873	.600	.929

City of Riverside  
 N/S: East La Cadena Drive  
 E/W: Columbia Avenue  
 Weather: Clear

File Name : 03\_RIV\_E La Cadena\_Columbia AM  
 Site Code : 20120202  
 Start Date : 4/16/2020  
 Page No : 1

Groups Printed- Total Volume

Start Time	East La Cadena Drive Southbound				Columbia Avenue Westbound				East La Cadena Drive Northbound				Columbia Avenue Eastbound				Int. Total
	Left	Thru	Right	App. Total	Left	Thru	Right	App. Total	Left	Thru	Right	App. Total	Left	Thru	Right	App. Total	
07:00 AM	53	5	50	108	1	70	30	101	3	2	3	8	10	71	4	85	302
07:15 AM	46	2	40	88	3	55	21	79	3	4	0	7	18	50	7	75	249
07:30 AM	49	1	36	86	1	68	32	101	2	7	4	13	29	71	4	104	304
07:45 AM	54	3	46	103	3	69	28	100	4	3	6	13	19	86	9	114	330
<b>Total</b>	<b>202</b>	<b>11</b>	<b>172</b>	<b>385</b>	<b>8</b>	<b>262</b>	<b>111</b>	<b>381</b>	<b>12</b>	<b>16</b>	<b>13</b>	<b>41</b>	<b>76</b>	<b>278</b>	<b>24</b>	<b>378</b>	<b>1185</b>
08:00 AM	48	3	51	102	3	57	25	85	4	3	4	11	22	45	5	72	270
08:15 AM	44	2	47	93	1	55	31	87	1	0	3	4	14	60	6	80	264
08:30 AM	42	4	42	88	2	73	20	95	3	3	1	7	20	55	3	78	268
08:45 AM	43	3	45	91	0	59	26	85	5	3	1	9	20	62	2	84	269
<b>Total</b>	<b>177</b>	<b>12</b>	<b>185</b>	<b>374</b>	<b>6</b>	<b>244</b>	<b>102</b>	<b>352</b>	<b>13</b>	<b>9</b>	<b>9</b>	<b>31</b>	<b>76</b>	<b>222</b>	<b>16</b>	<b>314</b>	<b>1071</b>
<b>Grand Total</b>	<b>379</b>	<b>23</b>	<b>357</b>	<b>759</b>	<b>14</b>	<b>506</b>	<b>213</b>	<b>733</b>	<b>25</b>	<b>25</b>	<b>22</b>	<b>72</b>	<b>152</b>	<b>500</b>	<b>40</b>	<b>692</b>	<b>2256</b>
Apprch %	49.9	3	47		1.9	69	29.1		34.7	34.7	30.6		22	72.3	5.8		
Total %	16.8	1	15.8	33.6	0.6	22.4	9.4	32.5	1.1	1.1	1	3.2	6.7	22.2	1.8	30.7	

Start Time	East La Cadena Drive Southbound				Columbia Avenue Westbound				East La Cadena Drive Northbound				Columbia Avenue Eastbound				Int. Total
	Left	Thru	Right	App. Total	Left	Thru	Right	App. Total	Left	Thru	Right	App. Total	Left	Thru	Right	App. Total	
Peak Hour Analysis From 07:00 AM to 08:45 AM - Peak 1 of 1																	
Peak Hour for Entire Intersection Begins at 07:00 AM																	
07:00 AM	53	<b>5</b>	<b>50</b>	<b>108</b>	1	<b>70</b>	30	<b>101</b>	3	2	3	8	10	71	4	85	302
07:15 AM	46	2	40	88	<b>3</b>	55	21	79	3	4	0	7	18	50	7	75	249
07:30 AM	49	1	36	86	1	68	<b>32</b>	101	2	<b>7</b>	4	<b>13</b>	<b>29</b>	71	4	104	304
07:45 AM	<b>54</b>	3	46	103	3	69	28	100	<b>4</b>	3	<b>6</b>	13	19	<b>86</b>	<b>9</b>	<b>114</b>	<b>330</b>
<b>Total Volume</b>	<b>202</b>	<b>11</b>	<b>172</b>	<b>385</b>	<b>8</b>	<b>262</b>	<b>111</b>	<b>381</b>	<b>12</b>	<b>16</b>	<b>13</b>	<b>41</b>	<b>76</b>	<b>278</b>	<b>24</b>	<b>378</b>	<b>1185</b>
% App. Total	52.5	2.9	44.7		2.1	68.8	29.1		29.3	39	31.7		20.1	73.5	6.3		
PHF	.935	.550	.860	.891	.667	.936	.867	.943	.750	.571	.542	.788	.655	.808	.667	.829	.898

City of Riverside  
 N/S: East La Cadena Drive  
 E/W: Columbia Avenue  
 Weather: Clear

File Name : 03\_RIV\_E La Cadena\_Columbia AM  
 Site Code : 20120202  
 Start Date : 4/16/2020  
 Page No : 2

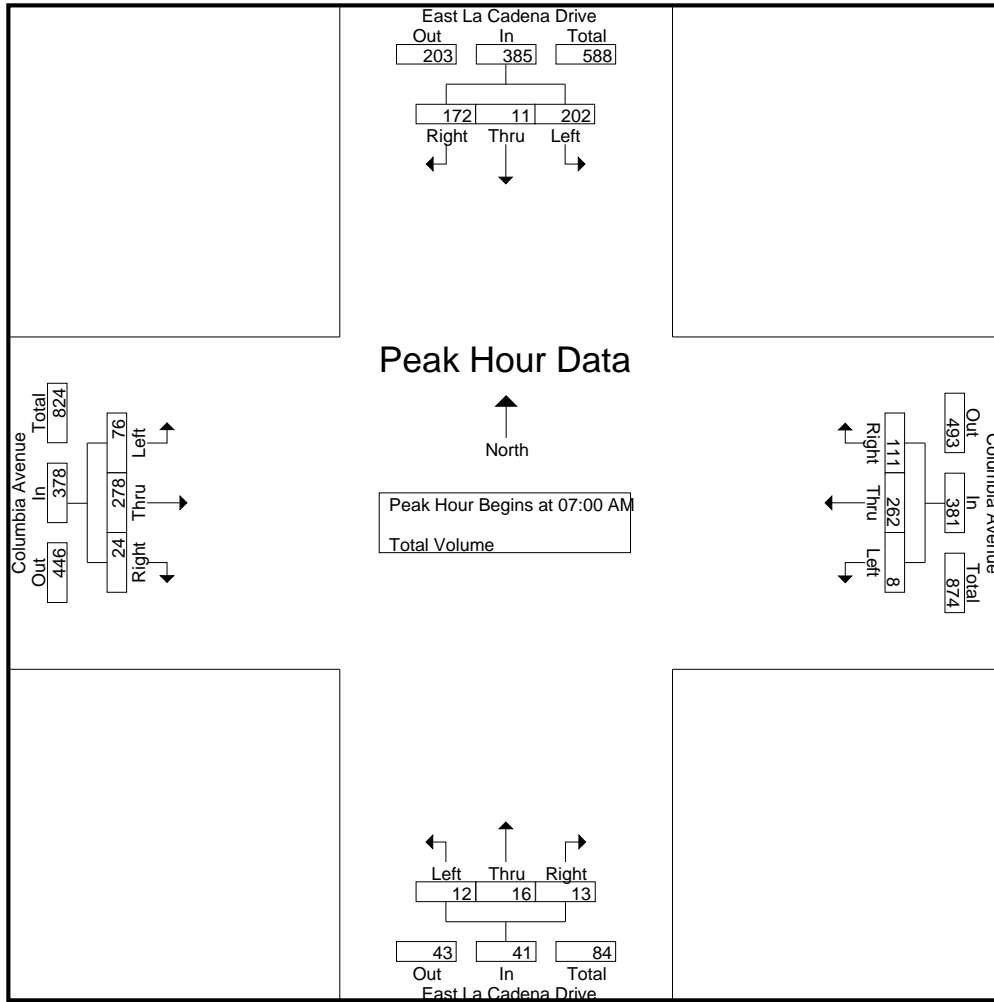

Peak Hour Analysis From 07:00 AM to 08:45 AM - Peak 1 of 1  
 Peak Hour for Each Approach Begins at:

	07:45 AM				07:00 AM				07:15 AM				07:00 AM			
+0 mins.	<b>54</b>	3	46	<b>103</b>	1	<b>70</b>	30	<b>101</b>	3	4	0	7	10	71	4	85
+15 mins.	48	3	<b>51</b>	102	<b>3</b>	55	21	79	2	<b>7</b>	4	<b>13</b>	18	50	7	75
+30 mins.	44	2	47	93	1	68	<b>32</b>	101	<b>4</b>	3	<b>6</b>	13	<b>29</b>	71	4	104
+45 mins.	42	<b>4</b>	42	88	3	69	28	100	4	3	4	11	19	<b>86</b>	<b>9</b>	<b>114</b>
Total Volume	188	12	186	386	8	262	111	381	13	17	14	44	76	278	24	378
% App. Total	48.7	3.1	48.2		2.1	68.8	29.1		29.5	38.6	31.8		20.1	73.5	6.3	
PHF	.870	.750	.912	.937	.667	.936	.867	.943	.813	.607	.583	.846	.655	.808	.667	.829

City of Riverside  
 N/S: East La Cadena Drive  
 E/W: Columbia Avenue  
 Weather: Clear

File Name : 03\_RIV\_E La Cadena\_Columbia PM  
 Site Code : 20120202  
 Start Date : 4/16/2020  
 Page No : 1

Groups Printed- Total Volume

Start Time	East La Cadena Drive Southbound				Columbia Avenue Westbound				East La Cadena Drive Northbound				Columbia Avenue Eastbound				Int. Total
	Left	Thru	Right	App. Total	Left	Thru	Right	App. Total	Left	Thru	Right	App. Total	Left	Thru	Right	App. Total	
04:00 PM	27	2	65	94	2	135	64	201	4	9	5	18	31	95	10	136	449
04:15 PM	39	4	64	107	0	101	55	156	9	4	3	16	22	85	9	116	395
04:30 PM	31	7	62	100	3	116	52	171	2	3	3	8	30	77	10	117	396
04:45 PM	42	4	61	107	2	101	61	164	7	11	1	19	19	67	5	91	381
Total	139	17	252	408	7	453	232	692	22	27	12	61	102	324	34	460	1621
05:00 PM	30	3	74	107	2	122	69	193	4	8	2	14	33	76	12	121	435
05:15 PM	36	9	56	101	0	89	51	140	8	3	8	19	16	78	7	101	361
05:30 PM	24	6	48	78	6	102	39	147	1	12	12	25	15	55	6	76	326
05:45 PM	26	4	44	74	2	77	36	115	3	6	4	13	13	53	10	76	278
Total	116	22	222	360	10	390	195	595	16	29	26	71	77	262	35	374	1400
Grand Total	255	39	474	768	17	843	427	1287	38	56	38	132	179	586	69	834	3021
Apprch %	33.2	5.1	61.7		1.3	65.5	33.2		28.8	42.4	28.8		21.5	70.3	8.3		
Total %	8.4	1.3	15.7	25.4	0.6	27.9	14.1	42.6	1.3	1.9	1.3	4.4	5.9	19.4	2.3	27.6	

Start Time	East La Cadena Drive Southbound				Columbia Avenue Westbound				East La Cadena Drive Northbound				Columbia Avenue Eastbound				Int. Total
	Left	Thru	Right	App. Total	Left	Thru	Right	App. Total	Left	Thru	Right	App. Total	Left	Thru	Right	App. Total	
Peak Hour Analysis From 04:00 PM to 05:45 PM - Peak 1 of 1																	
Peak Hour for Entire Intersection Begins at 04:00 PM																	
04:00 PM	27	2	<b>65</b>	94	2	<b>135</b>	<b>64</b>	<b>201</b>	4	9	<b>5</b>	18	<b>31</b>	<b>95</b>	<b>10</b>	<b>136</b>	<b>449</b>
04:15 PM	39	4	64	<b>107</b>	0	101	55	156	<b>9</b>	4	3	16	22	85	9	116	395
04:30 PM	31	<b>7</b>	62	100	<b>3</b>	116	52	171	2	3	3	8	30	77	10	117	396
04:45 PM	<b>42</b>	4	61	107	2	101	61	164	7	<b>11</b>	1	<b>19</b>	19	67	5	91	381
Total Volume	139	17	252	408	7	453	232	692	22	27	12	61	102	324	34	460	1621
% App. Total	34.1	4.2	61.8		1	65.5	33.5		36.1	44.3	19.7		22.2	70.4	7.4		
PHF	.827	.607	.969	.953	.583	.839	.906	.861	.611	.614	.600	.803	.823	.853	.850	.846	.903

City of Riverside  
 N/S: East La Cadena Drive  
 E/W: Columbia Avenue  
 Weather: Clear

File Name : 03\_RIV\_E La Cadena\_Columbia PM  
 Site Code : 20120202  
 Start Date : 4/16/2020  
 Page No : 2

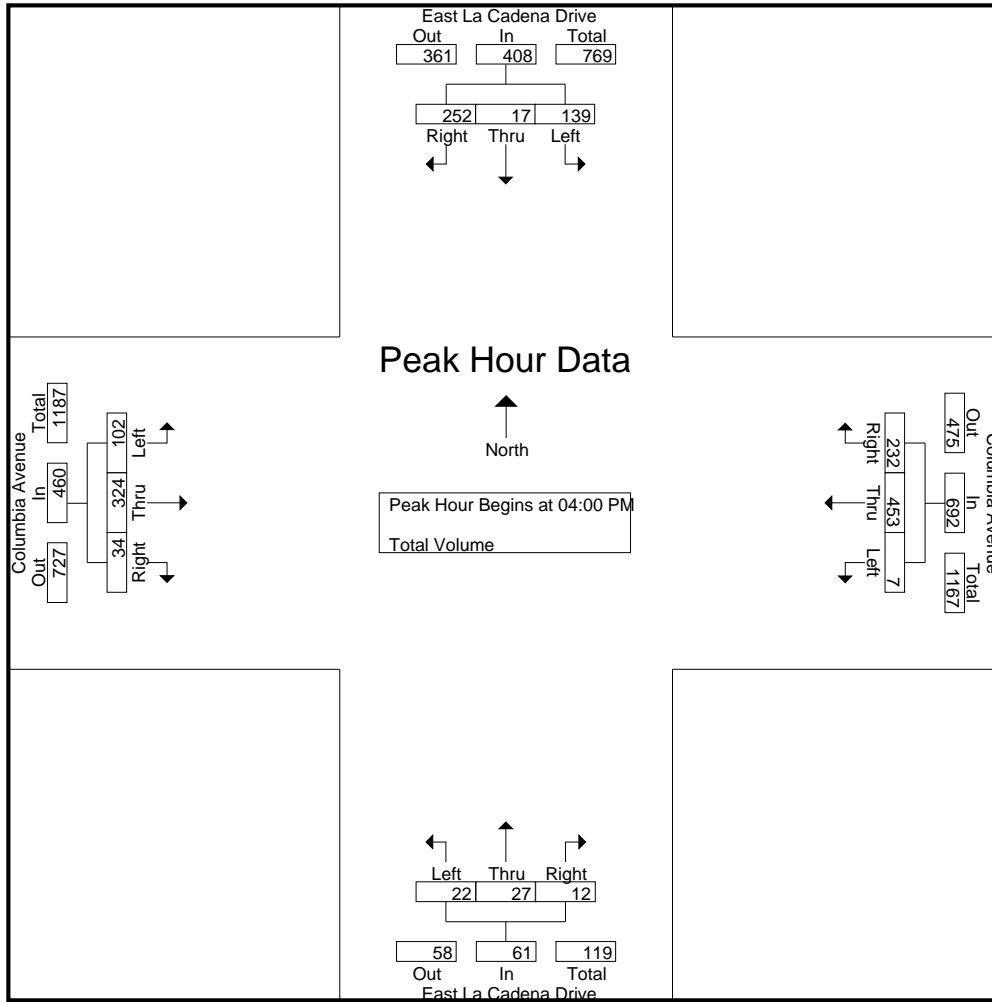

Peak Hour Analysis From 04:00 PM to 05:45 PM - Peak 1 of 1  
 Peak Hour for Each Approach Begins at:

	04:15 PM				04:00 PM				04:45 PM				04:00 PM			
+0 mins.	39	4	64	<b>107</b>	2	<b>135</b>	<b>64</b>	<b>201</b>	7	11	1	19	<b>31</b>	<b>95</b>	<b>10</b>	<b>136</b>
+15 mins.	31	<b>7</b>	62	100	0	101	55	156	4	8	2	14	22	85	9	116
+30 mins.	<b>42</b>	4	61	107	<b>3</b>	116	52	171	<b>8</b>	3	8	19	30	77	10	117
+45 mins.	30	3	<b>74</b>	107	2	101	61	164	1	<b>12</b>	<b>12</b>	<b>25</b>	19	67	5	91
Total Volume	142	18	261	421	7	453	232	692	20	34	23	77	102	324	34	460
% App. Total	33.7	4.3	62		1	65.5	33.5		26	44.2	29.9		22.2	70.4	7.4	
PHF	.845	.643	.882	.984	.583	.839	.906	.861	.625	.708	.479	.770	.823	.853	.850	.846

County of Riverside  
 N/S: Mt Vernon Avenue  
 E/W: Center Street  
 Weather: Clear

File Name : 04\_CRV\_Mt Vernon\_Center AM  
 Site Code : 20120202  
 Start Date : 4/16/2020  
 Page No : 1

Groups Printed- Total Volume

Start Time	Mt Vernon Avenue Southbound				Center Street Westbound				Mt Vernon Avenue Northbound				Center Street Eastbound				Int. Total
	Left	Thru	Right	App. Total	Left	Thru	Right	App. Total	Left	Thru	Right	App. Total	Left	Thru	Right	App. Total	
07:00 AM	4	12	5	21	1	10	9	20	0	18	1	19	5	6	2	13	73
07:15 AM	2	19	6	27	0	8	5	13	0	15	2	17	8	4	4	16	73
07:30 AM	5	10	3	18	1	7	11	19	3	21	1	25	3	2	2	7	69
07:45 AM	1	25	4	30	8	8	4	20	1	20	3	24	2	2	5	9	83
Total	12	66	18	96	10	33	29	72	4	74	7	85	18	14	13	45	298
08:00 AM	0	13	2	15	2	5	5	12	1	20	4	25	3	6	4	13	65
08:15 AM	3	15	4	22	3	12	10	25	4	20	4	28	6	7	3	16	91
08:30 AM	1	12	8	21	5	7	8	20	3	15	1	19	6	1	3	10	70
08:45 AM	5	14	10	29	1	12	5	18	4	12	3	19	2	2	3	7	73
Total	9	54	24	87	11	36	28	75	12	67	12	91	17	16	13	46	299
Grand Total	21	120	42	183	21	69	57	147	16	141	19	176	35	30	26	91	597
Apprch %	11.5	65.6	23		14.3	46.9	38.8		9.1	80.1	10.8		38.5	33	28.6		
Total %	3.5	20.1	7	30.7	3.5	11.6	9.5	24.6	2.7	23.6	3.2	29.5	5.9	5	4.4	15.2	

Start Time	Mt Vernon Avenue Southbound				Center Street Westbound				Mt Vernon Avenue Northbound				Center Street Eastbound				Int. Total
	Left	Thru	Right	App. Total	Left	Thru	Right	App. Total	Left	Thru	Right	App. Total	Left	Thru	Right	App. Total	
Peak Hour Analysis From 07:00 AM to 08:45 AM - Peak 1 of 1																	
Peak Hour for Entire Intersection Begins at 07:45 AM																	
07:45 AM	1	25	4	30	8	8	4	20	1	20	3	24	2	2	5	9	83
08:00 AM	0	13	2	15	2	5	5	12	1	20	4	25	3	6	4	13	65
08:15 AM	3	15	4	22	3	12	10	25	4	20	4	28	6	7	3	16	91
08:30 AM	1	12	8	21	5	7	8	20	3	15	1	19	6	1	3	10	70
Total Volume	5	65	18	88	18	32	27	77	9	75	12	96	17	16	15	48	309
% App. Total	5.7	73.9	20.5		23.4	41.6	35.1		9.4	78.1	12.5		35.4	33.3	31.2		
PHF	.417	.650	.563	.733	.563	.667	.675	.770	.563	.938	.750	.857	.708	.571	.750	.750	.849

County of Riverside  
 N/S: Mt Vernon Avenue  
 E/W: Center Street  
 Weather: Clear

File Name : 04\_CRV\_Mt Vernon\_Center AM  
 Site Code : 20120202  
 Start Date : 4/16/2020  
 Page No : 2

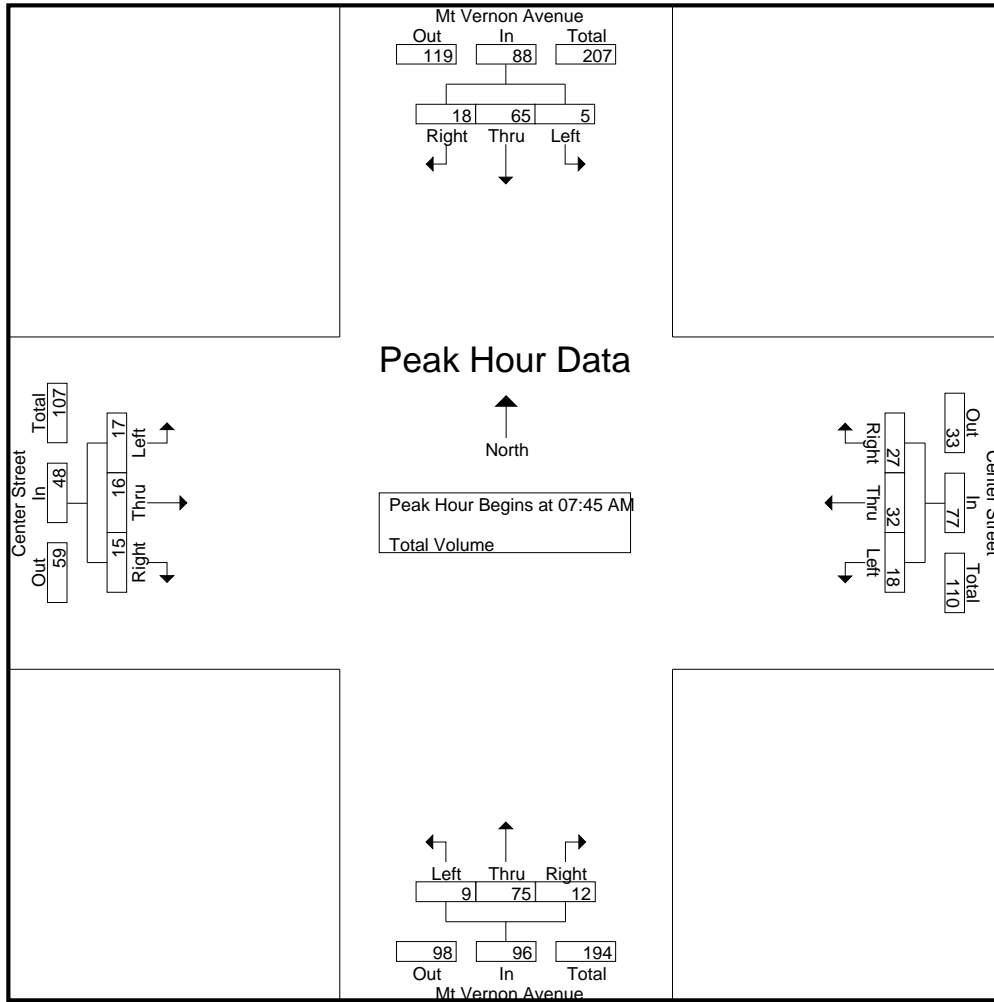

Peak Hour Analysis From 07:00 AM to 08:45 AM - Peak 1 of 1  
 Peak Hour for Each Approach Begins at:

	07:00 AM				07:45 AM				07:30 AM				07:45 AM			
+0 mins.	4	12	5	21	<b>8</b>	8	4	20	3	<b>21</b>	1	25	2	2	<b>5</b>	9
+15 mins.	2	19	<b>6</b>	27	2	5	5	12	1	20	3	24	3	6	4	13
+30 mins.	<b>5</b>	10	3	18	3	<b>12</b>	<b>10</b>	<b>25</b>	1	20	<b>4</b>	25	<b>6</b>	<b>7</b>	3	<b>16</b>
+45 mins.	1	<b>25</b>	4	<b>30</b>	5	7	8	20	<b>4</b>	20	4	<b>28</b>	6	1	3	10
Total Volume	12	66	18	96	18	32	27	77	9	81	12	102	17	16	15	48
% App. Total	12.5	68.8	18.8		23.4	41.6	35.1		8.8	79.4	11.8		35.4	33.3	31.2	
PHF	.600	.660	.750	.800	.563	.667	.675	.770	.563	.964	.750	.911	.708	.571	.750	.750

County of Riverside  
 N/S: Mt Vernon Avenue  
 E/W: Center Street  
 Weather: Clear

File Name : 04\_CRV\_Mt Vernon\_Center PM  
 Site Code : 20120202  
 Start Date : 4/16/2020  
 Page No : 1

Groups Printed- Total Volume

Start Time	Mt Vernon Avenue Southbound				Center Street Westbound				Mt Vernon Avenue Northbound				Center Street Eastbound				Int. Total
	Left	Thru	Right	App. Total	Left	Thru	Right	App. Total	Left	Thru	Right	App. Total	Left	Thru	Right	App. Total	
04:00 PM	7	27	10	44	4	6	5	15	3	41	2	46	12	4	1	17	122
04:15 PM	6	33	12	51	1	5	5	11	3	39	1	43	7	9	5	21	126
04:30 PM	5	27	9	41	3	3	4	10	1	33	1	35	13	9	1	23	109
04:45 PM	6	29	8	43	2	5	5	12	2	25	2	29	7	4	3	14	98
Total	24	116	39	179	10	19	19	48	9	138	6	153	39	26	10	75	455
05:00 PM	4	25	6	35	0	6	6	12	2	39	5	46	9	8	1	18	111
05:15 PM	14	29	13	56	1	4	6	11	1	29	0	30	5	6	4	15	112
05:30 PM	7	26	7	40	1	3	7	11	4	30	4	38	8	6	2	16	105
05:45 PM	12	22	9	43	0	5	8	13	4	29	2	35	13	17	5	35	126
Total	37	102	35	174	2	18	27	47	11	127	11	149	35	37	12	84	454
Grand Total	61	218	74	353	12	37	46	95	20	265	17	302	74	63	22	159	909
Apprch %	17.3	61.8	21		12.6	38.9	48.4		6.6	87.7	5.6		46.5	39.6	13.8		
Total %	6.7	24	8.1	38.8	1.3	4.1	5.1	10.5	2.2	29.2	1.9	33.2	8.1	6.9	2.4	17.5	

Start Time	Mt Vernon Avenue Southbound				Center Street Westbound				Mt Vernon Avenue Northbound				Center Street Eastbound				Int. Total
	Left	Thru	Right	App. Total	Left	Thru	Right	App. Total	Left	Thru	Right	App. Total	Left	Thru	Right	App. Total	
Peak Hour Analysis From 04:00 PM to 05:45 PM - Peak 1 of 1																	
Peak Hour for Entire Intersection Begins at 04:00 PM																	
04:00 PM	7	27	10	44	4	6	5	15	3	41	2	46	12	4	1	17	122
04:15 PM	6	33	12	51	1	5	5	11	3	39	1	43	7	9	5	21	126
04:30 PM	5	27	9	41	3	3	4	10	1	33	1	35	13	9	1	23	109
04:45 PM	6	29	8	43	2	5	5	12	2	25	2	29	7	4	3	14	98
Total Volume	24	116	39	179	10	19	19	48	9	138	6	153	39	26	10	75	455
% App. Total	13.4	64.8	21.8		20.8	39.6	39.6		5.9	90.2	3.9		52	34.7	13.3		
PHF	.857	.879	.813	.877	.625	.792	.950	.800	.750	.841	.750	.832	.750	.722	.500	.815	.903

County of Riverside  
 N/S: Mt Vernon Avenue  
 E/W: Center Street  
 Weather: Clear

File Name : 04\_CRV\_Mt Vernon\_Center PM  
 Site Code : 20120202  
 Start Date : 4/16/2020  
 Page No : 2

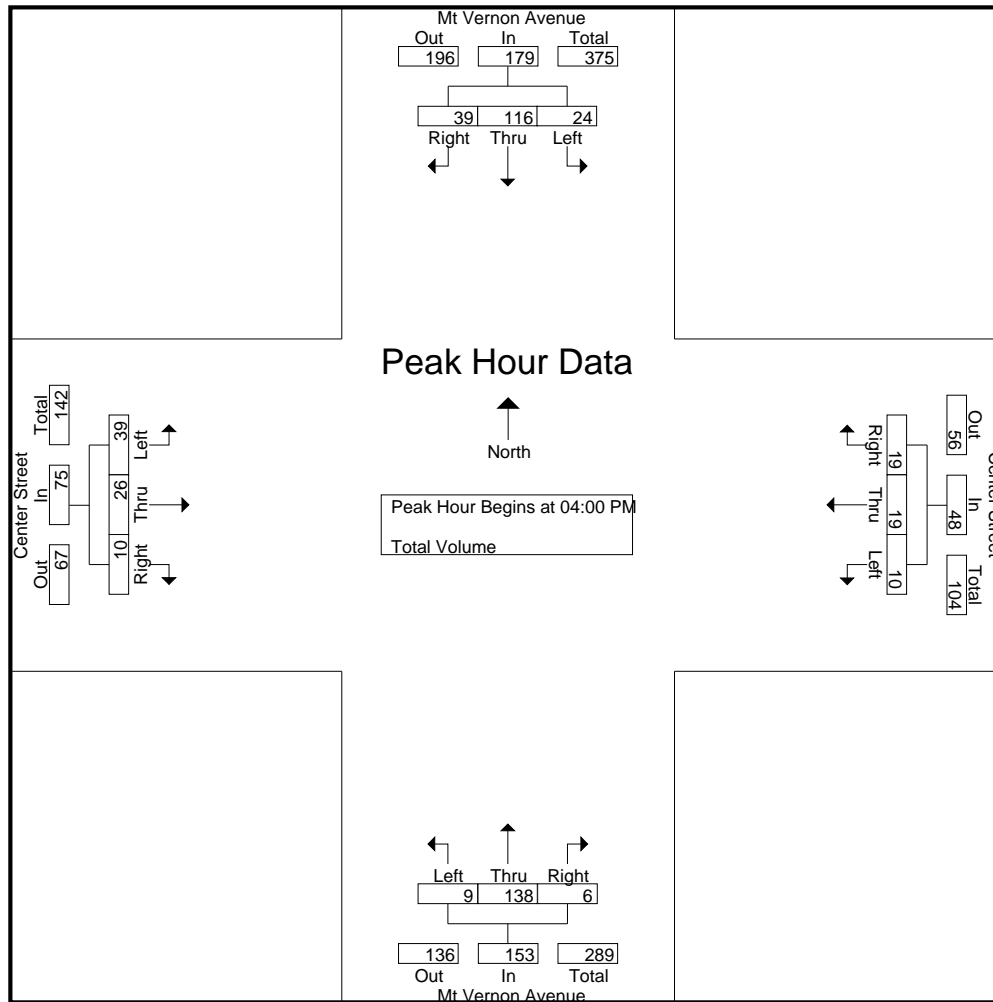

Peak Hour Analysis From 04:00 PM to 05:45 PM - Peak 1 of 1  
 Peak Hour for Each Approach Begins at:

	04:00 PM				04:00 PM				04:00 PM				05:00 PM			
+0 mins.	7	27	10	44	4	6	5	15	3	41	2	46	9	8	1	18
+15 mins.	6	33	12	51	1	5	5	11	3	39	1	43	5	6	4	15
+30 mins.	5	27	9	41	3	3	4	10	1	33	1	35	8	6	2	16
+45 mins.	6	29	8	43	2	5	5	12	2	25	2	29	13	17	5	35
Total Volume	24	116	39	179	10	19	19	48	9	138	6	153	35	37	12	84
% App. Total	13.4	64.8	21.8		20.8	39.6	39.6		5.9	90.2	3.9		41.7	44	14.3	
PHF	.857	.879	.813	.877	.625	.792	.950	.800	.750	.841	.750	.832	.673	.544	.600	.600

County of Riverside  
 N/S: Michigan Avenue  
 E/W: Center Street  
 Weather: Clear

File Name : 05\_CRV\_Michigan\_Center AM  
 Site Code : 20120202  
 Start Date : 4/16/2020  
 Page No : 1

Groups Printed- Total Volume

Start Time	Michigan Avenue Southbound				Center Street Westbound				Michigan Avenue Northbound				Center Street Eastbound				Int. Total
	Left	Thru	Right	App. Total	Left	Thru	Right	App. Total	Left	Thru	Right	App. Total	Left	Thru	Right	App. Total	
07:00 AM	0	1	6	7	0	14	1	15	2	0	0	2	5	12	2	19	43
07:15 AM	1	5	3	9	1	19	1	21	0	1	1	2	0	12	0	12	44
07:30 AM	1	1	4	6	0	11	1	12	0	2	0	2	2	6	0	8	28
07:45 AM	0	2	7	9	1	15	1	17	0	1	1	2	4	9	2	15	43
<b>Total</b>	<b>2</b>	<b>9</b>	<b>20</b>	<b>31</b>	<b>2</b>	<b>59</b>	<b>4</b>	<b>65</b>	<b>2</b>	<b>4</b>	<b>2</b>	<b>8</b>	<b>11</b>	<b>39</b>	<b>4</b>	<b>54</b>	<b>158</b>
08:00 AM	1	2	4	7	0	16	1	17	1	7	0	8	5	12	2	19	51
08:15 AM	0	1	1	2	0	12	1	13	1	1	0	2	3	7	0	10	27
08:30 AM	0	5	3	8	0	18	1	19	1	2	0	3	6	12	0	18	48
08:45 AM	0	1	3	4	2	20	1	23	0	2	0	2	4	10	1	15	44
<b>Total</b>	<b>1</b>	<b>9</b>	<b>11</b>	<b>21</b>	<b>2</b>	<b>66</b>	<b>4</b>	<b>72</b>	<b>3</b>	<b>12</b>	<b>0</b>	<b>15</b>	<b>18</b>	<b>41</b>	<b>3</b>	<b>62</b>	<b>170</b>
<b>Grand Total</b>	<b>3</b>	<b>18</b>	<b>31</b>	<b>52</b>	<b>4</b>	<b>125</b>	<b>8</b>	<b>137</b>	<b>5</b>	<b>16</b>	<b>2</b>	<b>23</b>	<b>29</b>	<b>80</b>	<b>7</b>	<b>116</b>	<b>328</b>
Apprch %	5.8	34.6	59.6		2.9	91.2	5.8		21.7	69.6	8.7		25	69	6		
Total %	0.9	5.5	9.5	15.9	1.2	38.1	2.4	41.8	1.5	4.9	0.6	7	8.8	24.4	2.1	35.4	

Start Time	Michigan Avenue Southbound				Center Street Westbound				Michigan Avenue Northbound				Center Street Eastbound				Int. Total
	Left	Thru	Right	App. Total	Left	Thru	Right	App. Total	Left	Thru	Right	App. Total	Left	Thru	Right	App. Total	
Peak Hour Analysis From 07:00 AM to 08:45 AM - Peak 1 of 1																	
Peak Hour for Entire Intersection Begins at 08:00 AM																	
08:00 AM	1	2	4	7	0	16	1	17	1	7	0	8	5	12	2	19	51
08:15 AM	0	1	1	2	0	12	1	13	1	1	0	2	3	7	0	10	27
08:30 AM	0	5	3	8	0	18	1	19	1	2	0	3	6	12	0	18	48
08:45 AM	0	1	3	4	2	20	1	23	0	2	0	2	4	10	1	15	44
<b>Total Volume</b>	<b>1</b>	<b>9</b>	<b>11</b>	<b>21</b>	<b>2</b>	<b>66</b>	<b>4</b>	<b>72</b>	<b>3</b>	<b>12</b>	<b>0</b>	<b>15</b>	<b>18</b>	<b>41</b>	<b>3</b>	<b>62</b>	<b>170</b>
% App. Total	4.8	42.9	52.4		2.8	91.7	5.6		20	80	0		29	66.1	4.8		
PHF	.250	.450	.688	.656	.250	.825	1.00	.783	.750	.429	.000	.469	.750	.854	.375	.816	.833

County of Riverside  
 N/S: Michigan Avenue  
 E/W: Center Street  
 Weather: Clear

File Name : 05\_CRV\_Michigan\_Center AM  
 Site Code : 20120202  
 Start Date : 4/16/2020  
 Page No : 2

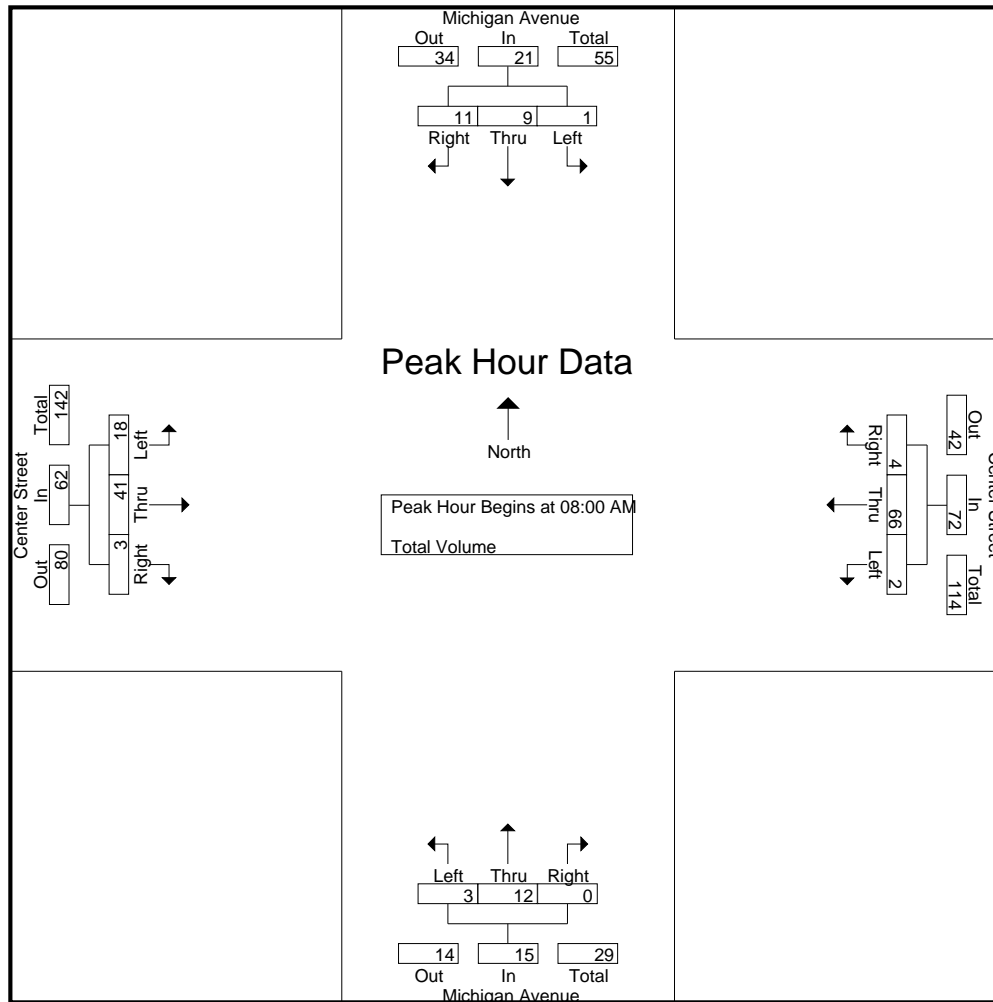

Peak Hour Analysis From 07:00 AM to 08:45 AM - Peak 1 of 1  
 Peak Hour for Each Approach Begins at:

	07:00 AM				08:00 AM				07:45 AM				07:45 AM			
+0 mins.	0	1	6	7	0	16	1	17	0	1	1	2	4	9	2	15
+15 mins.	1	5	3	9	0	12	1	13	1	7	0	8	5	12	2	19
+30 mins.	1	1	4	6	0	18	1	19	1	1	0	2	3	7	0	10
+45 mins.	0	2	7	9	2	20	1	23	1	2	0	3	6	12	0	18
Total Volume	2	9	20	31	2	66	4	72	3	11	1	15	18	40	4	62
% App. Total	6.5	29	64.5		2.8	91.7	5.6		20	73.3	6.7		29	64.5	6.5	
PHF	.500	.450	.714	.861	.250	.825	1.000	.783	.750	.393	.250	.469	.750	.833	.500	.816

County of Riverside  
 N/S: Michigan Avenue  
 E/W: Center Street  
 Weather: Clear

File Name : 05\_CRV\_Michigan\_Center PM  
 Site Code : 20120202  
 Start Date : 4/16/2020  
 Page No : 1

Groups Printed- Total Volume

Start Time	Michigan Avenue Southbound				Center Street Westbound				Michigan Avenue Northbound				Center Street Eastbound				Int. Total
	Left	Thru	Right	App. Total	Left	Thru	Right	App. Total	Left	Thru	Right	App. Total	Left	Thru	Right	App. Total	
04:00 PM	0	3	4	7	1	20	1	22	1	2	0	3	16	21	0	37	69
04:15 PM	3	4	10	17	2	20	4	26	1	3	0	4	10	24	0	34	81
04:30 PM	2	7	8	17	1	17	5	23	0	1	2	3	10	23	2	35	78
04:45 PM	1	8	9	18	3	12	1	16	0	7	3	10	11	22	0	33	77
Total	6	22	31	59	7	69	11	87	2	13	5	20	47	90	2	139	305
05:00 PM	0	9	8	17	1	12	1	14	2	3	0	5	11	18	0	29	65
05:15 PM	2	2	12	16	0	14	4	18	1	3	1	5	10	24	0	34	73
05:30 PM	4	4	9	17	3	11	1	15	2	2	0	4	4	13	0	17	53
05:45 PM	2	5	11	18	1	18	1	20	0	5	0	5	4	40	1	45	88
Total	8	20	40	68	5	55	7	67	5	13	1	19	29	95	1	125	279
Grand Total	14	42	71	127	12	124	18	154	7	26	6	39	76	185	3	264	584
Apprch %	11	33.1	55.9		7.8	80.5	11.7		17.9	66.7	15.4		28.8	70.1	1.1		
Total %	2.4	7.2	12.2	21.7	2.1	21.2	3.1	26.4	1.2	4.5	1	6.7	13	31.7	0.5	45.2	

Start Time	Michigan Avenue Southbound				Center Street Westbound				Michigan Avenue Northbound				Center Street Eastbound				Int. Total
	Left	Thru	Right	App. Total	Left	Thru	Right	App. Total	Left	Thru	Right	App. Total	Left	Thru	Right	App. Total	
Peak Hour Analysis From 04:00 PM to 05:45 PM - Peak 1 of 1																	
Peak Hour for Entire Intersection Begins at 04:00 PM																	
04:00 PM	0	3	4	7	1	<b>20</b>	1	22	1	2	0	3	<b>16</b>	21	0	<b>37</b>	69
04:15 PM	<b>3</b>	4	<b>10</b>	17	2	20	4	<b>26</b>	1	3	0	4	10	<b>24</b>	0	34	<b>81</b>
04:30 PM	2	7	8	17	1	17	<b>5</b>	23	0	1	2	3	10	23	<b>2</b>	35	78
04:45 PM	1	<b>8</b>	9	<b>18</b>	<b>3</b>	12	1	16	0	<b>7</b>	<b>3</b>	<b>10</b>	11	22	0	33	77
Total Volume	6	22	31	59	7	69	11	87	2	13	5	20	47	90	2	139	305
% App. Total	10.2	37.3	52.5		8	79.3	12.6		10	65	25		33.8	64.7	1.4		
PHF	.500	.688	.775	.819	.583	.863	.550	.837	.500	.464	.417	.500	.734	.938	.250	.939	.941

County of Riverside  
 N/S: Michigan Avenue  
 E/W: Center Street  
 Weather: Clear

File Name : 05\_CRV\_Michigan\_Center PM  
 Site Code : 20120202  
 Start Date : 4/16/2020  
 Page No : 2

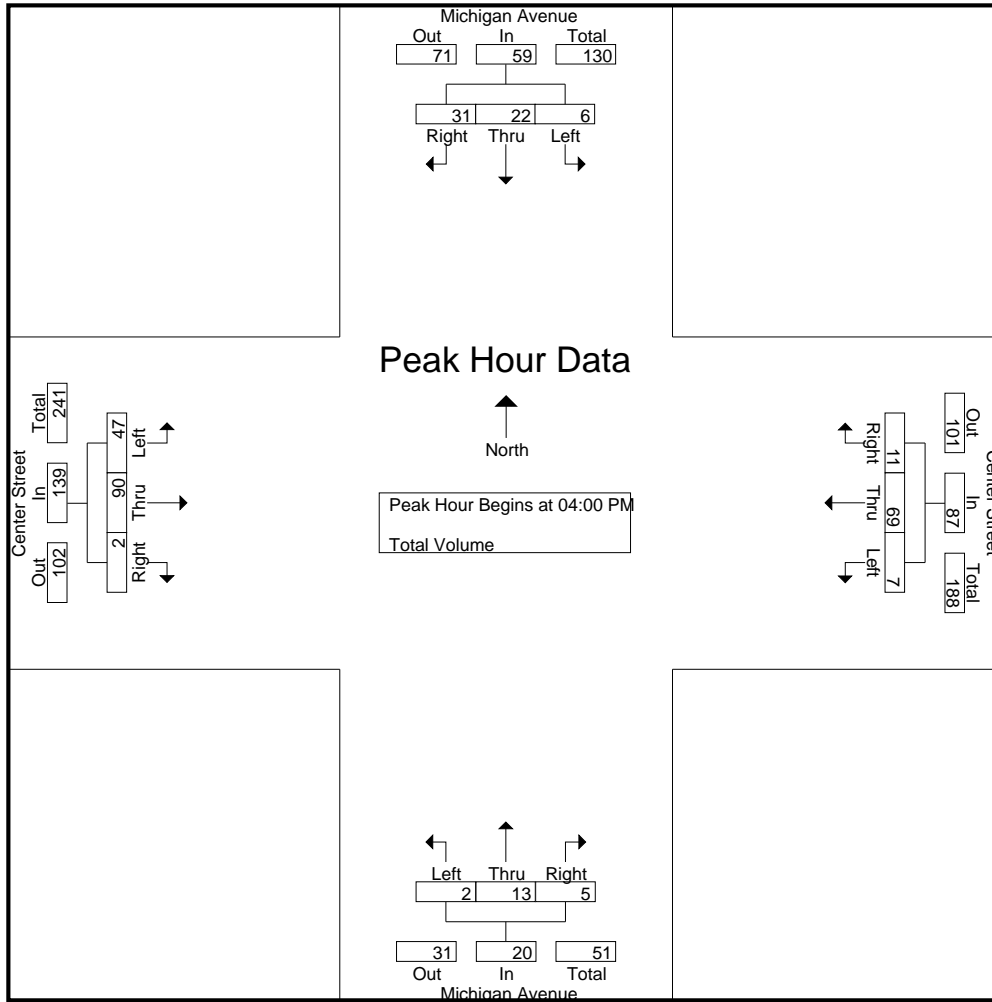

Peak Hour Analysis From 04:00 PM to 05:45 PM - Peak 1 of 1  
 Peak Hour for Each Approach Begins at:

	04:15 PM				04:00 PM				04:45 PM				04:00 PM			
+0 mins.	3	4	10	17	1	20	1	22	0	7	3	10	16	21	0	37
+15 mins.	2	7	8	17	2	20	4	26	2	3	0	5	10	24	0	34
+30 mins.	1	8	9	18	1	17	5	23	1	3	1	5	10	23	2	35
+45 mins.	0	9	8	17	3	12	1	16	2	2	0	4	11	22	0	33
Total Volume	6	28	35	69	7	69	11	87	5	15	4	24	47	90	2	139
% App. Total	8.7	40.6	50.7		8	79.3	12.6		20.8	62.5	16.7		33.8	64.7	1.4	
PHF	.500	.778	.875	.958	.583	.863	.550	.837	.625	.536	.333	.600	.734	.938	.250	.939

County of Riverside  
 N/S: Mt Vernon Avenue  
 E/W: Main Street  
 Weather: Clear

File Name : 06\_CRV\_Mt Vernon\_Main AM  
 Site Code : 20120202  
 Start Date : 4/16/2020  
 Page No : 1

Groups Printed- Total Volume

Start Time	Mt Vernon Avenue Southbound				Main Street Westbound				Mt Vernon Avenue Northbound				Main Street Eastbound				Int. Total
	Left	Thru	Right	App. Total	Left	Thru	Right	App. Total	Left	Thru	Right	App. Total	Left	Thru	Right	App. Total	
07:00 AM	2	20	6	28	2	0	4	6	0	29	1	30	2	1	1	4	68
07:15 AM	1	26	4	31	0	2	2	4	4	21	0	25	3	0	0	3	63
07:30 AM	1	19	4	24	0	2	5	7	3	35	0	38	5	5	2	12	81
07:45 AM	1	26	7	34	2	1	5	8	1	23	0	24	7	1	0	8	74
Total	5	91	21	117	4	5	16	25	8	108	1	117	17	7	3	27	286
08:00 AM	2	19	2	23	0	2	1	3	1	31	0	32	5	0	0	5	63
08:15 AM	0	16	2	18	1	2	0	3	2	33	0	35	1	1	2	4	60
08:30 AM	2	22	3	27	1	2	2	5	3	27	1	31	3	0	0	3	66
08:45 AM	3	28	4	35	1	1	2	4	3	18	0	21	1	2	1	4	64
Total	7	85	11	103	3	7	5	15	9	109	1	119	10	3	3	16	253
Grand Total	12	176	32	220	7	12	21	40	17	217	2	236	27	10	6	43	539
Apprch %	5.5	80	14.5		17.5	30	52.5		7.2	91.9	0.8		62.8	23.3	14		
Total %	2.2	32.7	5.9	40.8	1.3	2.2	3.9	7.4	3.2	40.3	0.4	43.8	5	1.9	1.1	8	

Start Time	Mt Vernon Avenue Southbound				Main Street Westbound				Mt Vernon Avenue Northbound				Main Street Eastbound				Int. Total
	Left	Thru	Right	App. Total	Left	Thru	Right	App. Total	Left	Thru	Right	App. Total	Left	Thru	Right	App. Total	
Peak Hour Analysis From 07:00 AM to 08:45 AM - Peak 1 of 1																	
Peak Hour for Entire Intersection Begins at 07:00 AM																	
07:00 AM	2	20	6	28	2	0	4	6	0	29	1	30	2	1	1	4	68
07:15 AM	1	26	4	31	0	2	2	4	4	21	0	25	3	0	0	3	63
07:30 AM	1	19	4	24	0	2	5	7	3	35	0	38	5	5	2	12	81
07:45 AM	1	26	7	34	2	1	5	8	1	23	0	24	7	1	0	8	74
Total Volume	5	91	21	117	4	5	16	25	8	108	1	117	17	7	3	27	286
% App. Total	4.3	77.8	17.9		16	20	64		6.8	92.3	0.9		63	25.9	11.1		
PHF	.625	.875	.750	.860	.500	.625	.800	.781	.500	.771	.250	.770	.607	.350	.375	.563	.883

County of Riverside  
 N/S: Mt Vernon Avenue  
 E/W: Main Street  
 Weather: Clear

File Name : 06\_CRV\_Mt Vernon\_Main AM  
 Site Code : 20120202  
 Start Date : 4/16/2020  
 Page No : 2

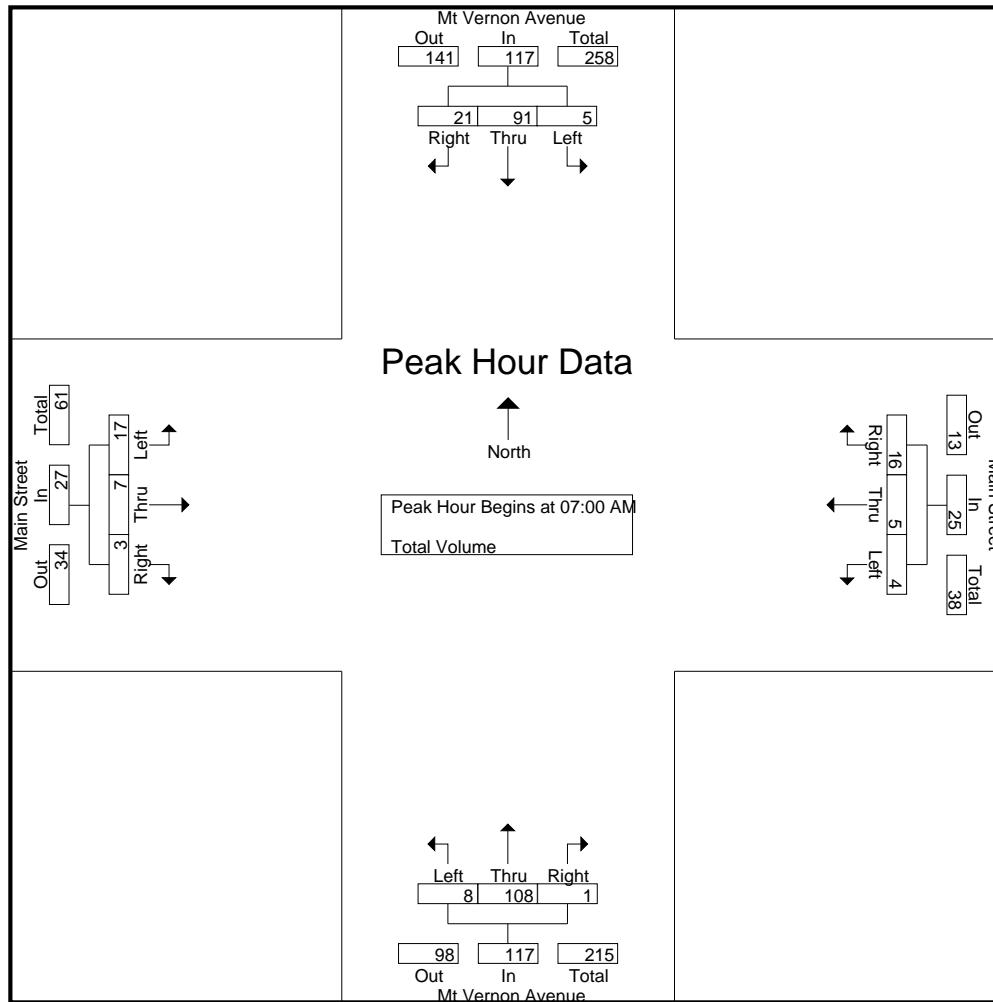

Peak Hour Analysis From 07:00 AM to 08:45 AM - Peak 1 of 1  
 Peak Hour for Each Approach Begins at:

	07:00 AM				07:00 AM				07:30 AM				07:30 AM			
+0 mins.	2	20	6	28	2	0	4	6	3	35	0	38	5	5	2	12
+15 mins.	1	26	4	31	0	2	2	4	1	23	0	24	7	1	0	8
+30 mins.	1	19	4	24	0	2	5	7	1	31	0	32	5	0	0	5
+45 mins.	1	26	7	34	2	1	5	8	2	33	0	35	1	1	2	4
Total Volume	5	91	21	117	4	5	16	25	7	122	0	129	18	7	4	29
% App. Total	4.3	77.8	17.9		16	20	64		5.4	94.6	0		62.1	24.1	13.8	
PHF	.625	.875	.750	.860	.500	.625	.800	.781	.583	.871	.000	.849	.643	.350	.500	.604

County of Riverside  
 N/S: Mt Vernon Avenue  
 E/W: Main Street  
 Weather: Clear

File Name : 06\_CRV\_Mt Vernon\_Main PM  
 Site Code : 20120202  
 Start Date : 4/16/2020  
 Page No : 1

Groups Printed- Total Volume

Start Time	Mt Vernon Avenue Southbound				Main Street Westbound				Mt Vernon Avenue Northbound				Main Street Eastbound				Int. Total
	Left	Thru	Right	App. Total	Left	Thru	Right	App. Total	Left	Thru	Right	App. Total	Left	Thru	Right	App. Total	
04:00 PM	7	46	6	59	1	4	2	7	4	54	0	58	2	4	1	7	131
04:15 PM	7	46	2	55	2	3	3	8	5	47	1	53	8	3	1	12	128
04:30 PM	6	35	5	46	0	3	5	8	1	43	3	47	9	4	2	15	116
04:45 PM	3	48	10	61	2	3	3	8	0	39	2	41	6	2	1	9	119
Total	23	175	23	221	5	13	13	31	10	183	6	199	25	13	5	43	494
05:00 PM	5	34	6	45	0	1	3	4	1	44	4	49	9	3	0	12	110
05:15 PM	7	61	7	75	1	1	5	7	1	49	2	52	4	7	4	15	149
05:30 PM	5	44	6	55	1	3	2	6	0	49	3	52	7	2	0	9	122
05:45 PM	5	39	6	50	0	3	4	7	1	46	1	48	9	7	0	16	121
Total	22	178	25	225	2	8	14	24	3	188	10	201	29	19	4	52	502
Grand Total	45	353	48	446	7	21	27	55	13	371	16	400	54	32	9	95	996
Apprch %	10.1	79.1	10.8		12.7	38.2	49.1		3.2	92.8	4		56.8	33.7	9.5		
Total %	4.5	35.4	4.8	44.8	0.7	2.1	2.7	5.5	1.3	37.2	1.6	40.2	5.4	3.2	0.9	9.5	

Start Time	Mt Vernon Avenue Southbound				Main Street Westbound				Mt Vernon Avenue Northbound				Main Street Eastbound				Int. Total
	Left	Thru	Right	App. Total	Left	Thru	Right	App. Total	Left	Thru	Right	App. Total	Left	Thru	Right	App. Total	
Peak Hour Analysis From 04:00 PM to 05:45 PM - Peak 1 of 1																	
Peak Hour for Entire Intersection Begins at 05:00 PM																	
05:00 PM	5	34	6	45	0	1	3	4	1	44	4	49	9	3	0	12	110
05:15 PM	7	61	7	75	1	1	5	7	1	49	2	52	4	7	4	15	149
05:30 PM	5	44	6	55	1	3	2	6	0	49	3	52	7	2	0	9	122
05:45 PM	5	39	6	50	0	3	4	7	1	46	1	48	9	7	0	16	121
Total Volume	22	178	25	225	2	8	14	24	3	188	10	201	29	19	4	52	502
% App. Total	9.8	79.1	11.1		8.3	33.3	58.3		1.5	93.5	5		55.8	36.5	7.7		
PHF	.786	.730	.893	.750	.500	.667	.700	.857	.750	.959	.625	.966	.806	.679	.250	.813	.842

County of Riverside  
 N/S: Mt Vernon Avenue  
 E/W: Main Street  
 Weather: Clear

File Name : 06\_CRV\_Mt Vernon\_Main PM  
 Site Code : 20120202  
 Start Date : 4/16/2020  
 Page No : 2

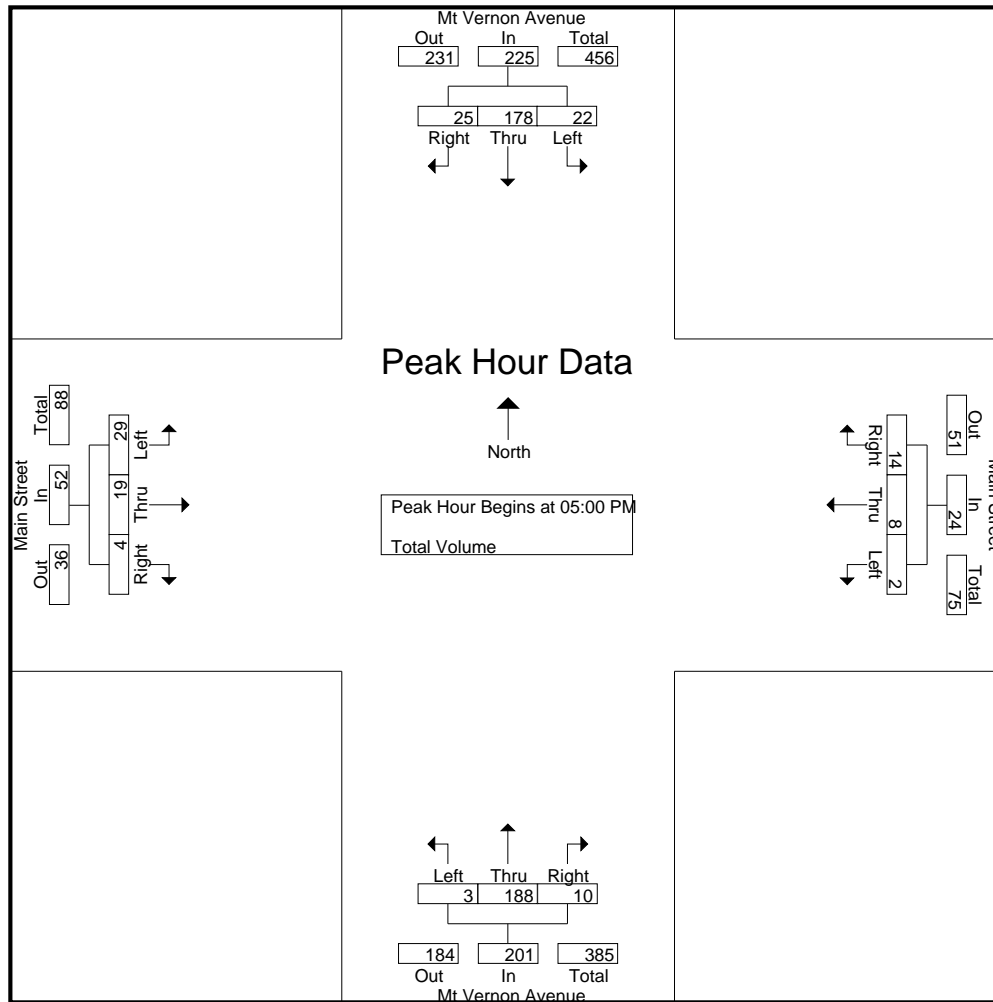

Peak Hour Analysis From 04:00 PM to 05:45 PM - Peak 1 of 1  
 Peak Hour for Each Approach Begins at:

	04:45 PM				04:00 PM				05:00 PM				05:00 PM			
+0 mins.	3	48	10	61	1	4	2	7	1	44	4	49	9	3	0	12
+15 mins.	5	34	6	45	2	3	3	8	1	49	2	52	4	7	4	15
+30 mins.	7	61	7	75	0	3	5	8	0	49	3	52	7	2	0	9
+45 mins.	5	44	6	55	2	3	3	8	1	46	1	48	9	7	0	16
Total Volume	20	187	29	236	5	13	13	31	3	188	10	201	29	19	4	52
% App. Total	8.5	79.2	12.3		16.1	41.9	41.9		1.5	93.5	5		55.8	36.5	7.7	
PHF	.714	.766	.725	.787	.625	.813	.650	.969	.750	.959	.625	.966	.806	.679	.250	.813

County of Riverside  
 N/S: Mt Vernon Avenue  
 E/W: Spring Street  
 Weather: Clear

File Name : 07\_CRV\_Mt Vernon\_Spring AM  
 Site Code : 20120202  
 Start Date : 4/16/2020  
 Page No : 1

Groups Printed- Total Volume

Start Time	Mt Vernon Avenue Southbound				Spring Street Westbound				Mt Vernon Avenue Northbound				Spring Street Eastbound				Int. Total
	Left	Thru	Right	App. Total	Left	Thru	Right	App. Total	Left	Thru	Right	App. Total	Left	Thru	Right	App. Total	
07:00 AM	0	16	3	19	1	0	8	9	1	11	1	13	1	0	0	1	42
07:15 AM	4	20	0	24	4	3	7	14	2	9	0	11	0	1	1	2	51
07:30 AM	2	12	0	14	2	3	14	19	0	14	0	14	1	1	2	4	51
07:45 AM	5	31	2	38	5	3	10	18	0	13	2	15	1	2	0	3	74
<b>Total</b>	<b>11</b>	<b>79</b>	<b>5</b>	<b>95</b>	<b>12</b>	<b>9</b>	<b>39</b>	<b>60</b>	<b>3</b>	<b>47</b>	<b>3</b>	<b>53</b>	<b>3</b>	<b>4</b>	<b>3</b>	<b>10</b>	<b>218</b>
08:00 AM	3	17	1	21	0	2	10	12	2	14	0	16	2	0	0	2	51
08:15 AM	2	14	4	20	3	2	7	12	1	20	2	23	0	0	2	2	57
08:30 AM	2	14	2	18	1	1	10	12	1	6	1	8	0	1	0	1	39
08:45 AM	1	17	0	18	1	1	4	6	0	17	1	18	2	2	0	4	46
<b>Total</b>	<b>8</b>	<b>62</b>	<b>7</b>	<b>77</b>	<b>5</b>	<b>6</b>	<b>31</b>	<b>42</b>	<b>4</b>	<b>57</b>	<b>4</b>	<b>65</b>	<b>4</b>	<b>3</b>	<b>2</b>	<b>9</b>	<b>193</b>
<b>Grand Total</b>	<b>19</b>	<b>141</b>	<b>12</b>	<b>172</b>	<b>17</b>	<b>15</b>	<b>70</b>	<b>102</b>	<b>7</b>	<b>104</b>	<b>7</b>	<b>118</b>	<b>7</b>	<b>7</b>	<b>5</b>	<b>19</b>	<b>411</b>
Apprch %	11	82	7		16.7	14.7	68.6		5.9	88.1	5.9		36.8	36.8	26.3		
Total %	4.6	34.3	2.9	41.8	4.1	3.6	17	24.8	1.7	25.3	1.7	28.7	1.7	1.7	1.2	4.6	

Start Time	Mt Vernon Avenue Southbound				Spring Street Westbound				Mt Vernon Avenue Northbound				Spring Street Eastbound				Int. Total
	Left	Thru	Right	App. Total	Left	Thru	Right	App. Total	Left	Thru	Right	App. Total	Left	Thru	Right	App. Total	
Peak Hour Analysis From 07:00 AM to 08:45 AM - Peak 1 of 1																	
Peak Hour for Entire Intersection Begins at 07:30 AM																	
07:30 AM	2	12	0	14	2	<b>3</b>	<b>14</b>	<b>19</b>	0	14	0	14	1	1	<b>2</b>	<b>4</b>	51
07:45 AM	<b>5</b>	<b>31</b>	2	<b>38</b>	<b>5</b>	3	10	18	0	13	<b>2</b>	15	1	<b>2</b>	0	3	<b>74</b>
08:00 AM	3	17	1	21	0	2	10	12	<b>2</b>	14	0	16	<b>2</b>	0	0	2	51
08:15 AM	2	14	<b>4</b>	20	3	2	7	12	1	<b>20</b>	2	<b>23</b>	0	0	2	2	57
Total Volume	12	74	7	93	10	10	41	61	3	61	4	68	4	3	4	11	233
% App. Total	12.9	79.6	7.5		16.4	16.4	67.2		4.4	89.7	5.9		36.4	27.3	36.4		
PHF	.600	.597	.438	.612	.500	.833	.732	.803	.375	.763	.500	.739	.500	.375	.500	.688	.787

County of Riverside  
 N/S: Mt Vernon Avenue  
 E/W: Spring Street  
 Weather: Clear

File Name : 07\_CRV\_Mt Vernon\_Spring AM  
 Site Code : 20120202  
 Start Date : 4/16/2020  
 Page No : 2

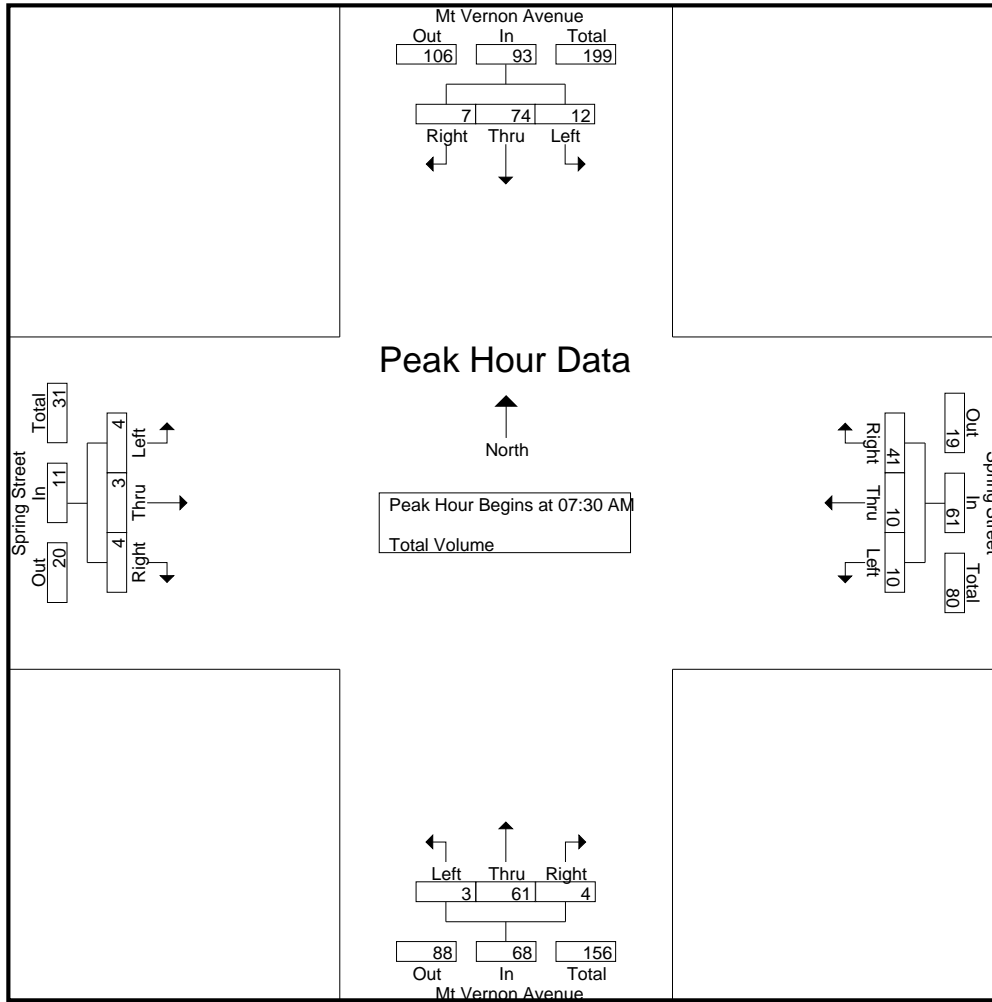

Peak Hour Analysis From 07:00 AM to 08:45 AM - Peak 1 of 1  
 Peak Hour for Each Approach Begins at:

	07:15 AM				07:15 AM				07:30 AM				07:15 AM			
+0 mins.	4	20	0	24	4	<b>3</b>	7	14	0	14	0	14	0	1	1	2
+15 mins.	2	12	0	14	2	3	<b>14</b>	<b>19</b>	0	13	<b>2</b>	15	1	1	<b>2</b>	<b>4</b>
+30 mins.	<b>5</b>	<b>31</b>	<b>2</b>	<b>38</b>	<b>5</b>	3	10	18	<b>2</b>	14	0	16	1	<b>2</b>	0	3
+45 mins.	3	17	1	21	0	2	10	12	1	<b>20</b>	2	<b>23</b>	<b>2</b>	0	0	2
Total Volume	14	80	3	97	11	11	41	63	3	61	4	68	4	4	3	11
% App. Total	14.4	82.5	3.1		17.5	17.5	65.1		4.4	89.7	5.9		36.4	36.4	27.3	
PHF	.700	.645	.375	.638	.550	.917	.732	.829	.375	.763	.500	.739	.500	.500	.375	.688

County of Riverside  
 N/S: Mt Vernon Avenue  
 E/W: Spring Street  
 Weather: Clear

File Name : 07\_CRV\_Mt Vernon\_Spring PM  
 Site Code : 20120202  
 Start Date : 4/16/2020  
 Page No : 1

Groups Printed- Total Volume

Start Time	Mt Vernon Avenue Southbound				Spring Street Westbound				Mt Vernon Avenue Northbound				Spring Street Eastbound				Int. Total
	Left	Thru	Right	App. Total	Left	Thru	Right	App. Total	Left	Thru	Right	App. Total	Left	Thru	Right	App. Total	
04:00 PM	16	21	1	38	3	1	11	15	1	37	2	40	2	3	0	5	98
04:15 PM	11	26	0	37	6	0	5	11	2	38	4	44	1	1	0	2	94
04:30 PM	10	16	0	26	3	2	4	9	0	26	3	29	1	3	2	6	70
04:45 PM	10	26	1	37	2	5	12	19	3	20	9	32	1	4	1	6	94
Total	47	89	2	138	14	8	32	54	6	121	18	145	5	11	3	19	356
05:00 PM	9	17	1	27	4	1	7	12	0	31	6	37	2	5	2	9	85
05:15 PM	10	23	1	34	4	2	6	12	0	24	5	29	2	6	1	9	84
05:30 PM	5	18	3	26	0	3	11	14	1	25	5	31	0	1	1	2	73
05:45 PM	10	10	0	20	1	0	8	9	2	19	6	27	1	0	0	1	57
Total	34	68	5	107	9	6	32	47	3	99	22	124	5	12	4	21	299
Grand Total	81	157	7	245	23	14	64	101	9	220	40	269	10	23	7	40	655
Apprch %	33.1	64.1	2.9		22.8	13.9	63.4		3.3	81.8	14.9		25	57.5	17.5		
Total %	12.4	24	1.1	37.4	3.5	2.1	9.8	15.4	1.4	33.6	6.1	41.1	1.5	3.5	1.1	6.1	

Start Time	Mt Vernon Avenue Southbound				Spring Street Westbound				Mt Vernon Avenue Northbound				Spring Street Eastbound				Int. Total
	Left	Thru	Right	App. Total	Left	Thru	Right	App. Total	Left	Thru	Right	App. Total	Left	Thru	Right	App. Total	
Peak Hour Analysis From 04:00 PM to 05:45 PM - Peak 1 of 1																	
Peak Hour for Entire Intersection Begins at 04:00 PM																	
04:00 PM	16	21	1	38	3	1	11	15	1	37	2	40	2	3	0	5	98
04:15 PM	11	26	0	37	6	0	5	11	2	38	4	44	1	1	0	2	94
04:30 PM	10	16	0	26	3	2	4	9	0	26	3	29	1	3	2	6	70
04:45 PM	10	26	1	37	2	5	12	19	3	20	9	32	1	4	1	6	94
Total Volume	47	89	2	138	14	8	32	54	6	121	18	145	5	11	3	19	356
% App. Total	34.1	64.5	1.4		25.9	14.8	59.3		4.1	83.4	12.4		26.3	57.9	15.8		
PHF	.734	.856	.500	.908	.583	.400	.667	.711	.500	.796	.500	.824	.625	.688	.375	.792	.908

County of Riverside  
 N/S: Mt Vernon Avenue  
 E/W: Spring Street  
 Weather: Clear

File Name : 07\_CRV\_Mt Vernon\_Spring PM  
 Site Code : 20120202  
 Start Date : 4/16/2020  
 Page No : 2

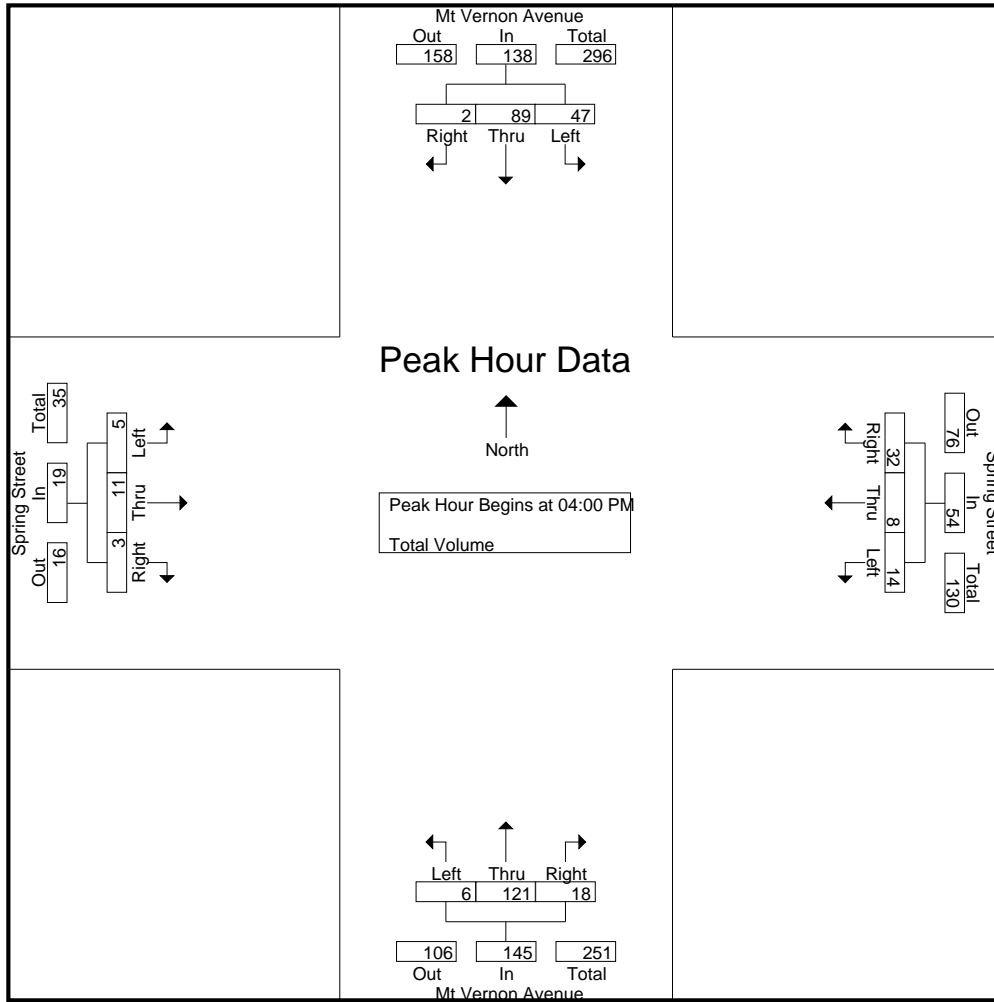

Peak Hour Analysis From 04:00 PM to 05:45 PM - Peak 1 of 1  
 Peak Hour for Each Approach Begins at:

	04:00 PM				04:45 PM				04:00 PM				04:30 PM			
+0 mins.	16	21	1	38	2	5	12	19	1	37	2	40	1	3	2	6
+15 mins.	11	26	0	37	4	1	7	12	2	38	4	44	1	4	1	6
+30 mins.	10	16	0	26	4	2	6	12	0	26	3	29	2	5	2	9
+45 mins.	10	26	1	37	0	3	11	14	3	20	9	32	2	6	1	9
Total Volume	47	89	2	138	10	11	36	57	6	121	18	145	6	18	6	30
% App. Total	34.1	64.5	1.4		17.5	19.3	63.2		4.1	83.4	12.4		20	60	20	
PHF	.734	.856	.500	.908	.625	.550	.750	.750	.500	.796	.500	.824	.750	.750	.750	.833

**APPENDIX C**

**EXISTING (2020) CONDITIONS  
INTERSECTION ANALYSIS CALCULATION WORKSHEETS**

THIS PAGE IS LEFT INTENTIONALLY BLANK

Lanes, Volumes, Timings  
1: Mt. Vernon Ave. & Center St.

Existing Conditions  
AM PEAK HOUR

Lane Group	EBL	EBT	EBR	WBL	WBT	WBR	NBL	NBT	NBR	SBL	SBT	SBR
Lane Configurations												
Traffic Volume (vph)	38	36	33	40	71	60	20	167	27	11	144	40
Future Volume (vph)	38	36	33	40	71	60	20	167	27	11	144	40
Ideal Flow (vphpl)	1900	1900	1900	1900	1900	1900	1900	1900	1900	1900	1900	1900
Storage Length (ft)	185		0	150		150	210		210	150		0
Storage Lanes	1		0	1		0	1		1	1		0
Taper Length (ft)	90			60			60			90		
Right Turn on Red			Yes			Yes			Yes			Yes
Link Speed (mph)		40			40			40			40	
Link Distance (ft)		2630			193			444			254	
Travel Time (s)		44.8			3.3			7.6			4.3	
Peak Hour Factor	0.85	0.85	0.85	0.85	0.85	0.85	0.85	0.85	0.85	0.85	0.85	0.85
Shared Lane Traffic (%)												
Turn Type	Prot	NA		Prot	NA		Prot	NA	Perm	Prot	NA	
Protected Phases	7	4		3	8		5	2		1	6	
Permitted Phases									2			
Detector Phase	7	4		3	8		5	2	2	1	6	
Switch Phase												
Minimum Initial (s)	4.0	4.0		4.0	4.0		4.0	4.0	4.0	4.0	4.0	
Minimum Split (s)	8.0	22.0		8.0	22.0		8.0	22.0	22.0	8.0	22.0	
Total Split (s)	8.0	22.0		8.0	22.0		8.0	22.0	22.0	8.0	22.0	
Total Split (%)	13.3%	36.7%		13.3%	36.7%		13.3%	36.7%	36.7%	13.3%	36.7%	
Yellow Time (s)	3.5	3.5		3.5	3.5		3.5	3.5	3.5	3.5	3.5	
All-Red Time (s)	0.5	0.5		0.5	0.5		0.5	0.5	0.5	0.5	0.5	
Lost Time Adjust (s)	0.0	0.0		0.0	0.0		0.0	0.0	0.0	0.0	0.0	
Total Lost Time (s)	4.0	4.0		4.0	4.0		4.0	4.0	4.0	4.0	4.0	
Lead/Lag	Lead	Lag		Lead	Lag		Lead	Lag	Lag	Lead	Lag	
Lead-Lag Optimize?	Yes	Yes		Yes	Yes		Yes	Yes	Yes	Yes	Yes	
Recall Mode	None	None		None	None		None	C-Max	C-Max	None	C-Max	

Intersection Summary





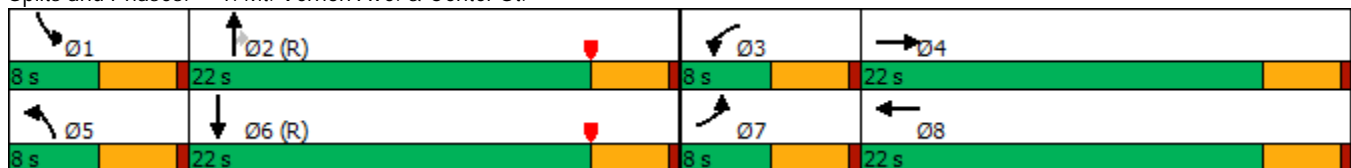

















Area Type: Other  
 Cycle Length: 60  
 Actuated Cycle Length: 60  
 Offset: 0 (0%), Referenced to phase 2:NBT and 6:SBT, Start of Yellow  
 Natural Cycle: 60  
 Control Type: Actuated-Coordinated

Splits and Phases: 1: Mt. Vernon Ave. & Center St.



























HCM 6th Signalized Intersection Summary  
 1: Mt. Vernon Ave. & Center St.

Existing Conditions  
 AM PEAK HOUR

												
Movement	EBL	EBT	EBR	WBL	WBT	WBR	NBL	NBT	NBR	SBL	SBT	SBR
Lane Configurations												
Traffic Volume (veh/h)	38	36	33	40	71	60	20	167	27	11	144	40
Future Volume (veh/h)	38	36	33	40	71	60	20	167	27	11	144	40
Initial Q (Qb), veh	0	0	0	0	0	0	0	0	0	0	0	0
Ped-Bike Adj(A_pbT)	1.00		1.00	1.00		1.00	1.00		1.00	1.00		1.00
Parking Bus, Adj	1.00	1.00	1.00	1.00	1.00	1.00	1.00	1.00	1.00	1.00	1.00	1.00
Work Zone On Approach		No			No			No			No	
Adj Sat Flow, veh/h/ln	1870	1870	1870	1870	1870	1870	1870	1870	1870	1870	1870	1870
Adj Flow Rate, veh/h	45	42	39	47	84	71	24	196	32	13	169	47
Peak Hour Factor	0.85	0.85	0.85	0.85	0.85	0.85	0.85	0.85	0.85	0.85	0.85	0.85
Percent Heavy Veh, %	2	2	2	2	2	2	2	2	2	2	2	2
Cap, veh/h	63	162	133	64	169	130	39	1116	946	23	1625	439
Arrive On Green	0.04	0.09	0.09	0.04	0.09	0.09	0.02	0.60	0.60	0.01	0.59	0.59
Sat Flow, veh/h	1781	1854	1519	1781	1915	1468	1781	1870	1585	1781	2765	747
Grp Volume(v), veh/h	45	40	41	47	77	78	24	196	32	13	107	109
Grp Sat Flow(s),veh/h/ln	1781	1777	1597	1781	1777	1606	1781	1870	1585	1781	1777	1736
Q Serve(g_s), s	1.5	1.3	1.4	1.6	2.5	2.8	0.8	2.8	0.5	0.4	1.6	1.7
Cycle Q Clear(g_c), s	1.5	1.3	1.4	1.6	2.5	2.8	0.8	2.8	0.5	0.4	1.6	1.7
Prop In Lane	1.00		0.95	1.00		0.91	1.00		1.00	1.00		0.43
Lane Grp Cap(c), veh/h	63	155	139	64	157	142	39	1116	946	23	1044	1020
V/C Ratio(X)	0.72	0.26	0.29	0.73	0.49	0.55	0.61	0.18	0.03	0.56	0.10	0.11
Avail Cap(c_a), veh/h	119	533	479	119	533	482	119	1116	946	119	1044	1020
HCM Platoon Ratio	1.00	1.00	1.00	1.00	1.00	1.00	1.00	1.00	1.00	1.00	1.00	1.00
Upstream Filter(I)	1.00	1.00	1.00	1.00	1.00	1.00	1.00	1.00	1.00	1.00	1.00	1.00
Uniform Delay (d), s/veh	28.7	25.6	25.6	28.6	26.1	26.2	29.1	5.4	5.0	29.4	5.4	5.4
Incr Delay (d2), s/veh	14.2	0.9	1.2	14.5	2.4	3.3	14.5	0.3	0.1	19.6	0.2	0.2
Initial Q Delay(d3),s/veh	0.0	0.0	0.0	0.0	0.0	0.0	0.0	0.0	0.0	0.0	0.0	0.0
%ile BackOfQ(50%),veh/ln	0.8	0.5	0.5	0.9	1.1	1.1	0.5	0.8	0.1	0.3	0.5	0.5
Unsig. Movement Delay, s/veh												
LnGrp Delay(d),s/veh	42.9	26.4	26.8	43.1	28.4	29.5	43.6	5.8	5.0	49.1	5.6	5.7
LnGrp LOS	D	C	C	D	C	C	D	A	A	D	A	A
Approach Vol, veh/h		126			202			252			229	
Approach Delay, s/veh		32.4			32.2			9.3			8.1	
Approach LOS		C			C			A			A	
Timer - Assigned Phs	1	2	3	4	5	6	7	8				
Phs Duration (G+Y+Rc), s	4.8	39.8	6.2	9.2	5.3	39.3	6.1	9.3				
Change Period (Y+Rc), s	4.0	4.0	4.0	4.0	4.0	4.0	4.0	4.0				
Max Green Setting (Gmax), s	4.0	18.0	4.0	18.0	4.0	18.0	4.0	18.0				
Max Q Clear Time (g_c+I1), s	2.4	4.8	3.6	3.4	2.8	3.7	3.5	4.8				
Green Ext Time (p_c), s	0.0	0.8	0.0	0.3	0.0	0.9	0.0	0.6				
<b>Intersection Summary</b>												
HCM 6th Ctrl Delay				18.3								
HCM 6th LOS				B								

Lanes, Volumes, Timings  
2: Michigan Ave. & Center St.

Existing Conditions  
AM PEAK HOUR

												
Lane Group	EBL	EBT	EBR	WBL	WBT	WBR	NBL	NBT	NBR	SBL	SBT	SBR
Lane Configurations		 			 			 			 	
Traffic Volume (vph)	40	91	7	4	147	9	7	27	0	2	20	24
Future Volume (vph)	40	91	7	4	147	9	7	27	0	2	20	24
Ideal Flow (vphpl)	1900	1900	1900	1900	1900	1900	1900	1900	1900	1900	1900	1900
Storage Length (ft)	0		50	0		50	0		50	115		0
Storage Lanes	0		1	0		1	0		1	1		1
Taper Length (ft)	90			90			90			90		
Link Speed (mph)		40			40			30			30	
Link Distance (ft)		841			2630			440			477	
Travel Time (s)		14.3			44.8			10.0			10.8	
Peak Hour Factor	0.83	0.83	0.83	0.83	0.83	0.83	0.83	0.83	0.83	0.83	0.83	0.83
Shared Lane Traffic (%)												
Sign Control		Stop			Stop			Stop			Stop	
<b>Intersection Summary</b>												
Area Type:	Other											
Control Type:	Unsignalized											

Intersection	
Intersection Delay, s/veh	8.6
Intersection LOS	A



















Movement	EBL	EBT	EBR	WBL	WBT	WBR	NBL	NBT	NBR	SBL	SBT	SBR
Lane Configurations		↔↔	↔		↔↔	↔		↔	↔		↔	↔
Traffic Vol, veh/h	40	91	7	4	147	9	7	27	0	2	20	24
Future Vol, veh/h	40	91	7	4	147	9	7	27	0	2	20	24
Peak Hour Factor	0.83	0.83	0.83	0.83	0.83	0.83	0.83	0.83	0.83	0.83	0.83	0.83
Heavy Vehicles, %	2	2	2	2	2	2	2	2	2	2	2	2
Mvmt Flow	48	110	8	5	177	11	8	33	0	2	24	29
Number of Lanes	0	2	1	0	2	1	0	1	1	0	1	1

Approach	EB	WB	NB	SB
Opposing Approach	WB	EB	SB	NB
Opposing Lanes	3	3	2	2
Conflicting Approach Left	SB	NB	EB	WB
Conflicting Lanes Left	2	2	3	3
Conflicting Approach Right	NB	SB	WB	EB
Conflicting Lanes Right	2	2	3	3
HCM Control Delay	8.7	8.7	8.8	8.2
HCM LOS	A	A	A	A

Lane	NBLn1	NBLn2	EBLn1	EBLn2	EBLn3	WBLn1	WBLn2	WBLn3	SBLn1	SBLn2
Vol Left, %	21%	0%	57%	0%	0%	8%	0%	0%	9%	0%
Vol Thru, %	79%	100%	43%	100%	0%	92%	100%	0%	91%	0%
Vol Right, %	0%	0%	0%	0%	100%	0%	0%	100%	0%	100%
Sign Control	Stop	Stop	Stop	Stop	Stop	Stop	Stop	Stop	Stop	Stop
Traffic Vol by Lane	34	0	70	61	7	53	98	9	22	24
LT Vol	7	0	40	0	0	4	0	0	2	0
Through Vol	27	0	30	61	0	49	98	0	20	0
RT Vol	0	0	0	0	7	0	0	9	0	24
Lane Flow Rate	41	0	85	73	8	64	118	11	27	29
Geometry Grp	8	8	8	8	8	8	8	8	8	8
Degree of Util (X)	0.065	0	0.129	0.106	0.011	0.092	0.17	0.013	0.041	0.039
Departure Headway (Hd)	5.681	5.578	5.494	5.209	4.506	5.207	5.169	4.466	5.603	4.858
Convergence, Y/N	Yes	Yes	Yes	Yes	Yes	Yes	Yes	Yes	Yes	Yes
Cap	629	0	652	688	793	688	694	800	637	734
Service Time	3.428	3.325	3.23	2.945	2.242	2.941	2.903	2.201	3.35	2.605
HCM Lane V/C Ratio	0.065	0	0.13	0.106	0.01	0.093	0.17	0.014	0.042	0.04
HCM Control Delay	8.8	8.3	9	8.6	7.3	8.5	9	7.3	8.6	7.8
HCM Lane LOS	A	N	A	A	A	A	A	A	A	A
HCM 95th-tile Q	0.2	0	0.4	0.4	0	0.3	0.6	0	0.1	0.1

Lanes, Volumes, Timings  
3: Mt. Vernon Ave. & Main St.

Existing Conditions  
AM PEAK HOUR

												
Lane Group	EBL	EBT	EBR	WBL	WBT	WBR	NBL	NBT	NBR	SBL	SBT	SBR
Lane Configurations												
Traffic Volume (vph)	38	16	7	9	11	36	18	240	2	11	202	47
Future Volume (vph)	38	16	7	9	11	36	18	240	2	11	202	47
Ideal Flow (vphpl)	1900	1900	1900	1900	1900	1900	1900	1900	1900	1900	1900	1900
Storage Length (ft)	0		50	0		0	0		50	0		50
Storage Lanes	0		1	0		0	0		1	0		1
Taper Length (ft)	90			90			90			90		
Link Speed (mph)		40			40			40			40	
Link Distance (ft)		1252			1253			777			936	
Travel Time (s)		21.3			21.4			13.2			16.0	
Peak Hour Factor	0.88	0.88	0.88	0.88	0.88	0.88	0.88	0.88	0.88	0.88	0.88	0.88
Shared Lane Traffic (%)												
Sign Control		Stop			Stop			Stop			Stop	
<b>Intersection Summary</b>												
Area Type:	Other											
Control Type:	Unsignalized											

Intersection	
Intersection Delay, s/veh	11.2
Intersection LOS	B

Movement	EBL	EBT	EBR	WBL	WBT	WBR	NBL	NBT	NBR	SBL	SBT	SBR
Lane Configurations		↖	↗		↔			↖	↗		↖↗	↗
Traffic Vol, veh/h	38	16	7	9	11	36	18	240	2	11	202	47
Future Vol, veh/h	38	16	7	9	11	36	18	240	2	11	202	47
Peak Hour Factor	0.88	0.88	0.88	0.88	0.88	0.88	0.88	0.88	0.88	0.88	0.88	0.88
Heavy Vehicles, %	2	2	2	2	2	2	2	2	2	2	2	2
Mvmt Flow	43	18	8	10	13	41	20	273	2	13	230	53
Number of Lanes	0	1	1	0	1	0	0	1	1	0	2	1

Approach	EB	WB	NB	SB
Opposing Approach	WB	EB	SB	NB
Opposing Lanes	1	2	3	2
Conflicting Approach Left	SB	NB	EB	WB
Conflicting Lanes Left	3	2	2	1
Conflicting Approach Right	NB	SB	WB	EB
Conflicting Lanes Right	2	3	1	2
HCM Control Delay	10.2	9.6	13.3	9.7
HCM LOS	B	A	B	A

Lane	NBLn1	NBLn2	EBLn1	EBLn2	WBLn1	SBLn1	SBLn2	SBLn3
Vol Left, %	7%	0%	70%	0%	16%	14%	0%	0%
Vol Thru, %	93%	0%	30%	0%	20%	86%	100%	0%
Vol Right, %	0%	100%	0%	100%	64%	0%	0%	100%
Sign Control	Stop	Stop	Stop	Stop	Stop	Stop	Stop	Stop
Traffic Vol by Lane	258	2	54	7	56	78	135	47
LT Vol	18	0	38	0	9	11	0	0
Through Vol	240	0	16	0	11	67	135	0
RT Vol	0	2	0	7	36	0	0	47
Lane Flow Rate	293	2	61	8	64	89	153	53
Geometry Grp	8	8	8	8	8	8	8	8
Degree of Util (X)	0.466	0.003	0.116	0.013	0.107	0.144	0.243	0.075
Departure Headway (Hd)	5.724	4.984	6.778	5.718	6.081	5.811	5.728	5.022
Convergence, Y/N	Yes	Yes	Yes	Yes	Yes	Yes	Yes	Yes
Cap	633	722	529	626	589	620	627	714
Service Time	3.428	2.688	4.514	3.454	3.82	3.526	3.456	2.75
HCM Lane V/C Ratio	0.463	0.003	0.115	0.013	0.109	0.144	0.244	0.074
HCM Control Delay	13.3	7.7	10.4	8.5	9.6	9.5	10.3	8.2
HCM Lane LOS	B	A	B	A	A	A	B	A
HCM 95th-tile Q	2.5	0	0.4	0	0.4	0.5	0.9	0.2

Lanes, Volumes, Timings  
4: Mt. Vernon Ave. & Spring St.

Existing Conditions  
AM PEAK HOUR

Lane Group	EBL	EBT	EBR	WBL	WBT	WBR	NBL	NBT	NBR	SBL	SBT	SBR
Lane Configurations												
Traffic Volume (vph)	9	7	9	22	22	91	7	135	9	27	164	16
Future Volume (vph)	9	7	9	22	22	91	7	135	9	27	164	16
Ideal Flow (vphpl)	1900	1900	1900	1900	1900	1900	1900	1900	1900	1900	1900	1900
Storage Length (ft)	140		0	165		0	200		0	205		205
Storage Lanes	1		0	1		0	1		0	1		1
Taper Length (ft)	90			60			90			90		
Right Turn on Red			Yes			Yes			Yes			Yes
Link Speed (mph)		30			30			40			40	
Link Distance (ft)		549			688			569			394	
Travel Time (s)		12.5			15.6			9.7			6.7	
Peak Hour Factor	0.79	0.79	0.79	0.79	0.79	0.79	0.79	0.79	0.79	0.79	0.79	0.79
Shared Lane Traffic (%)												
Turn Type	Prot	NA		Prot	NA		Prot	NA		Prot	NA	Perm
Protected Phases	7	4		3	8		5	2		1	6	
Permitted Phases												6
Detector Phase	7	4		3	8		5	2		1	6	6
Switch Phase												
Minimum Initial (s)	4.0	4.0		4.0	4.0		4.0	4.0		4.0	4.0	4.0
Minimum Split (s)	8.0	22.0		8.0	22.0		8.0	22.0		8.0	22.0	22.0
Total Split (s)	8.0	22.0		8.0	22.0		8.0	22.0		8.0	22.0	22.0
Total Split (%)	13.3%	36.7%		13.3%	36.7%		13.3%	36.7%		13.3%	36.7%	36.7%
Yellow Time (s)	3.5	3.5		3.5	3.5		3.5	3.5		3.5	3.5	3.5
All-Red Time (s)	0.5	0.5		0.5	0.5		0.5	0.5		0.5	0.5	0.5
Lost Time Adjust (s)	0.0	0.0		0.0	0.0		0.0	0.0		0.0	0.0	0.0
Total Lost Time (s)	4.0	4.0		4.0	4.0		4.0	4.0		4.0	4.0	4.0
Lead/Lag	Lead	Lag		Lead	Lag		Lead	Lag		Lead	Lag	Lag
Lead-Lag Optimize?	Yes	Yes		Yes	Yes		Yes	Yes		Yes	Yes	Yes
Recall Mode	None	None		None	None		None	C-Max		None	C-Max	C-Max

Intersection Summary





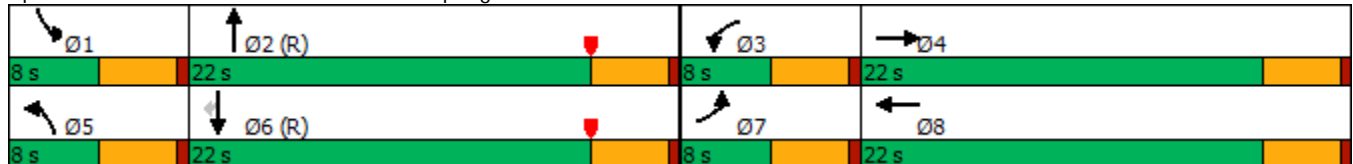

















Area Type: Other  
 Cycle Length: 60  
 Actuated Cycle Length: 60  
 Offset: 0 (0%), Referenced to phase 2:NBT and 6:SBT, Start of Yellow  
 Natural Cycle: 60  
 Control Type: Actuated-Coordinated

Splits and Phases: 4: Mt. Vernon Ave. & Spring St.



HCM 6th Signalized Intersection Summary  
4: Mt. Vernon Ave. & Spring St.

Existing Conditions  
AM PEAK HOUR

												
Movement	EBL	EBT	EBR	WBL	WBT	WBR	NBL	NBT	NBR	SBL	SBT	SBR
Lane Configurations												
Traffic Volume (veh/h)	9	7	9	22	22	91	7	135	9	27	164	16
Future Volume (veh/h)	9	7	9	22	22	91	7	135	9	27	164	16
Initial Q (Qb), veh	0	0	0	0	0	0	0	0	0	0	0	0
Ped-Bike Adj(A_pbT)	1.00		1.00	1.00		1.00	1.00		1.00	1.00		1.00
Parking Bus, Adj	1.00	1.00	1.00	1.00	1.00	1.00	1.00	1.00	1.00	1.00	1.00	1.00
Work Zone On Approach		No			No			No			No	
Adj Sat Flow, veh/h/ln	1870	1870	1870	1870	1870	1870	1870	1870	1870	1870	1870	1870
Adj Flow Rate, veh/h	11	9	11	28	28	115	9	171	11	34	208	20
Peak Hour Factor	0.79	0.79	0.79	0.79	0.79	0.79	0.79	0.79	0.79	0.79	0.79	0.79
Percent Heavy Veh, %	2	2	2	2	2	2	2	2	2	2	2	2
Cap, veh/h	20	82	101	44	39	159	17	1941	124	51	1107	938
Arrive On Green	0.01	0.11	0.11	0.02	0.12	0.12	0.01	0.69	0.69	0.03	0.71	0.71
Sat Flow, veh/h	1781	766	936	1781	320	1314	1781	3392	217	1781	1870	1585
Grp Volume(v), veh/h	11	0	20	28	0	143	9	89	93	34	208	20
Grp Sat Flow(s),veh/h/ln	1781	0	1702	1781	0	1634	1781	1777	1831	1781	1870	1585
Q Serve(g_s), s	0.4	0.0	0.6	0.9	0.0	5.1	0.3	1.0	1.0	1.1	2.2	0.2
Cycle Q Clear(g_c), s	0.4	0.0	0.6	0.9	0.0	5.1	0.3	1.0	1.0	1.1	2.2	0.2
Prop In Lane	1.00		0.55	1.00		0.80	1.00		0.12	1.00		1.00
Lane Grp Cap(c), veh/h	20	0	183	44	0	198	17	1017	1048	51	1107	938
V/C Ratio(X)	0.55	0.00	0.11	0.63	0.00	0.72	0.54	0.09	0.09	0.66	0.19	0.02
Avail Cap(c_a), veh/h	119	0	511	119	0	490	119	1017	1048	119	1107	938
HCM Platoon Ratio	1.00	1.00	1.00	1.00	1.00	1.00	1.20	1.20	1.20	1.20	1.20	1.20
Upstream Filter(I)	1.00	0.00	1.00	1.00	0.00	1.00	1.00	1.00	1.00	1.00	1.00	1.00
Uniform Delay (d), s/veh	29.5	0.0	24.2	29.0	0.0	25.4	29.5	4.2	4.2	28.7	3.9	3.6
Incr Delay (d2), s/veh	21.8	0.0	0.3	13.9	0.0	4.9	25.0	0.2	0.2	13.6	0.4	0.0
Initial Q Delay(d3),s/veh	0.0	0.0	0.0	0.0	0.0	0.0	0.0	0.0	0.0	0.0	0.0	0.0
%ile BackOfQ(50%),veh/ln	0.3	0.0	0.3	0.6	0.0	2.1	0.2	0.3	0.3	0.6	0.7	0.1
Unsig. Movement Delay, s/veh												
LnGrp Delay(d),s/veh	51.3	0.0	24.4	42.9	0.0	30.3	54.5	4.3	4.3	42.3	4.3	3.6
LnGrp LOS	D	A	C	D	A	C	D	A	A	D	A	A
Approach Vol, veh/h		31			171			191			262	
Approach Delay, s/veh		34.0			32.4			6.7			9.1	
Approach LOS		C			C			A			A	
Timer - Assigned Phs	1	2	3	4	5	6	7	8				
Phs Duration (G+Y+Rc), s	5.7	38.3	5.5	10.4	4.6	39.5	4.7	11.3				
Change Period (Y+Rc), s	4.0	4.0	4.0	4.0	4.0	4.0	4.0	4.0				
Max Green Setting (Gmax), s	4.0	18.0	4.0	18.0	4.0	18.0	4.0	18.0				
Max Q Clear Time (g_c+I1), s	3.1	3.0	2.9	2.6	2.3	4.2	2.4	7.1				
Green Ext Time (p_c), s	0.0	0.7	0.0	0.0	0.0	0.9	0.0	0.5				
<b>Intersection Summary</b>												
HCM 6th Ctrl Delay			15.7									
HCM 6th LOS			B									

Lanes, Volumes, Timings  
1: Mt. Vernon Ave. & Center St.

Existing Conditions  
PM PEAK HOUR

Lane Group	EBL	EBT	EBR	WBL	WBT	WBR	NBL	NBT	NBR	SBL	SBT	SBR
Lane Configurations												
Traffic Volume (vph)	70	47	18	18	34	34	16	248	11	43	209	70
Future Volume (vph)	70	47	18	18	34	34	16	248	11	43	209	70
Ideal Flow (vphpl)	1900	1900	1900	1900	1900	1900	1900	1900	1900	1900	1900	1900
Storage Length (ft)	185		0	150		150	210		210	150		0
Storage Lanes	1		0	1		0	1		1	1		0
Taper Length (ft)	90			60			60			90		
Right Turn on Red			Yes			Yes			Yes			Yes
Link Speed (mph)		40			40			40			40	
Link Distance (ft)		2630			193			444			254	
Travel Time (s)		44.8			3.3			7.6			4.3	
Peak Hour Factor	0.90	0.90	0.90	0.90	0.90	0.90	0.90	0.90	0.90	0.90	0.90	0.90
Shared Lane Traffic (%)												
Turn Type	Prot	NA		Prot	NA		Prot	NA	Perm	Prot	NA	
Protected Phases	7	4		3	8		5	2		1	6	
Permitted Phases									2			
Detector Phase	7	4		3	8		5	2	2	1	6	
Switch Phase												
Minimum Initial (s)	4.0	4.0		4.0	4.0		4.0	4.0	4.0	4.0	4.0	
Minimum Split (s)	8.0	22.0		8.0	22.0		8.0	22.0	22.0	8.0	22.0	
Total Split (s)	8.0	22.0		8.0	22.0		8.0	22.0	22.0	8.0	22.0	
Total Split (%)	13.3%	36.7%		13.3%	36.7%		13.3%	36.7%	36.7%	13.3%	36.7%	
Yellow Time (s)	3.5	3.5		3.5	3.5		3.5	3.5	3.5	3.5	3.5	
All-Red Time (s)	0.5	0.5		0.5	0.5		0.5	0.5	0.5	0.5	0.5	
Lost Time Adjust (s)	0.0	0.0		0.0	0.0		0.0	0.0	0.0	0.0	0.0	
Total Lost Time (s)	4.0	4.0		4.0	4.0		4.0	4.0	4.0	4.0	4.0	
Lead/Lag	Lead	Lag		Lead	Lag		Lead	Lag	Lag	Lead	Lag	
Lead-Lag Optimize?	Yes	Yes		Yes	Yes		Yes	Yes	Yes	Yes	Yes	
Recall Mode	None	None		None	None		None	C-Max	C-Max	None	C-Max	

Intersection Summary





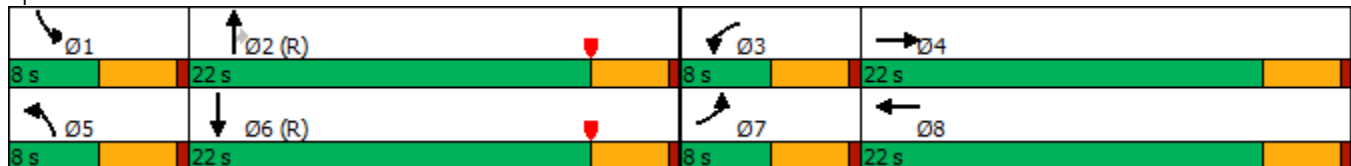

















Area Type: Other  
 Cycle Length: 60  
 Actuated Cycle Length: 60  
 Offset: 0 (0%), Referenced to phase 2:NBT and 6:SBT, Start of Yellow  
 Natural Cycle: 60  
 Control Type: Actuated-Coordinated

Splits and Phases: 1: Mt. Vernon Ave. & Center St.



























HCM 6th Signalized Intersection Summary  
 1: Mt. Vernon Ave. & Center St.

Existing Conditions  
 PM PEAK HOUR

												
Movement	EBL	EBT	EBR	WBL	WBT	WBR	NBL	NBT	NBR	SBL	SBT	SBR
Lane Configurations												
Traffic Volume (veh/h)	70	47	18	18	34	34	16	248	11	43	209	70
Future Volume (veh/h)	70	47	18	18	34	34	16	248	11	43	209	70
Initial Q (Qb), veh	0	0	0	0	0	0	0	0	0	0	0	0
Ped-Bike Adj(A_pbT)	1.00		1.00	1.00		1.00	1.00		1.00	1.00		1.00
Parking Bus, Adj	1.00	1.00	1.00	1.00	1.00	1.00	1.00	1.00	1.00	1.00	1.00	1.00
Work Zone On Approach		No			No			No			No	
Adj Sat Flow, veh/h/ln	1870	1870	1870	1870	1870	1870	1870	1870	1870	1870	1870	1870
Adj Flow Rate, veh/h	78	52	20	20	38	38	18	276	12	48	232	78
Peak Hour Factor	0.90	0.90	0.90	0.90	0.90	0.90	0.90	0.90	0.90	0.90	0.90	0.90
Percent Heavy Veh, %	2	2	2	2	2	2	2	2	2	2	2	2
Cap, veh/h	99	254	92	34	112	98	31	1082	917	65	1572	515
Arrive On Green	0.06	0.10	0.10	0.02	0.06	0.06	0.02	0.58	0.58	0.04	0.60	0.60
Sat Flow, veh/h	1781	2551	929	1781	1796	1568	1781	1870	1585	1781	2631	861
Grp Volume(v), veh/h	78	35	37	20	38	38	18	276	12	48	155	155
Grp Sat Flow(s),veh/h/ln	1781	1777	1703	1781	1777	1588	1781	1870	1585	1781	1777	1715
Q Serve(g_s), s	2.6	1.1	1.2	0.7	1.2	1.4	0.6	4.4	0.2	1.6	2.3	2.4
Cycle Q Clear(g_c), s	2.6	1.1	1.2	0.7	1.2	1.4	0.6	4.4	0.2	1.6	2.3	2.4
Prop In Lane	1.00		0.55	1.00		0.99	1.00		1.00	1.00		0.50
Lane Grp Cap(c), veh/h	99	177	169	34	111	99	31	1082	917	65	1062	1025
V/C Ratio(X)	0.79	0.20	0.22	0.59	0.34	0.39	0.58	0.26	0.01	0.73	0.15	0.15
Avail Cap(c_a), veh/h	119	533	511	119	533	476	119	1082	917	119	1062	1025
HCM Platoon Ratio	1.00	1.00	1.00	1.00	1.00	1.00	1.00	1.00	1.00	1.00	1.00	1.00
Upstream Filter(I)	1.00	1.00	1.00	1.00	1.00	1.00	1.00	1.00	1.00	1.00	1.00	1.00
Uniform Delay (d), s/veh	28.0	24.8	24.9	29.2	26.9	27.0	29.3	6.3	5.4	28.6	5.3	5.3
Incr Delay (d2), s/veh	24.5	0.5	0.6	15.6	1.8	2.4	16.4	0.6	0.0	14.6	0.3	0.3
Initial Q Delay(d3),s/veh	0.0	0.0	0.0	0.0	0.0	0.0	0.0	0.0	0.0	0.0	0.0	0.0
%ile BackOfQ(50%),veh/ln	1.7	0.4	0.5	0.4	0.5	0.6	0.4	1.4	0.1	0.9	0.7	0.7
Unsig. Movement Delay, s/veh												
LnGrp Delay(d),s/veh	52.5	25.4	25.5	44.8	28.7	29.5	45.6	6.8	5.4	43.2	5.6	5.7
LnGrp LOS	D	C	C	D	C	C	D	A	A	D	A	A
Approach Vol, veh/h		150			96			306			358	
Approach Delay, s/veh		39.5			32.4			9.1			10.7	
Approach LOS		D			C			A			B	
Timer - Assigned Phs	1	2	3	4	5	6	7	8				
Phs Duration (G+Y+Rc), s	6.2	38.7	5.1	10.0	5.0	39.9	7.3	7.8				
Change Period (Y+Rc), s	4.0	4.0	4.0	4.0	4.0	4.0	4.0	4.0				
Max Green Setting (Gmax), s	4.0	18.0	4.0	18.0	4.0	18.0	4.0	18.0				
Max Q Clear Time (g_c+I1), s	3.6	6.4	2.7	3.2	2.6	4.4	4.6	3.4				
Green Ext Time (p_c), s	0.0	1.1	0.0	0.2	0.0	1.3	0.0	0.2				
<b>Intersection Summary</b>												
HCM 6th Ctrl Delay				17.2								
HCM 6th LOS				B								

Lanes, Volumes, Timings  
2: Michigan Ave. & Center St.

Existing Conditions  
PM PEAK HOUR

												
Lane Group	EBL	EBT	EBR	WBL	WBT	WBR	NBL	NBT	NBR	SBL	SBT	SBR
Lane Configurations		 			 			 			 	
Traffic Volume (vph)	85	162	4	13	124	20	4	23	9	11	40	56
Future Volume (vph)	85	162	4	13	124	20	4	23	9	11	40	56
Ideal Flow (vphpl)	1900	1900	1900	1900	1900	1900	1900	1900	1900	1900	1900	1900
Storage Length (ft)	0		50	0		50	0		50	115		0
Storage Lanes	0		1	0		1	0		1	1		1
Taper Length (ft)	90			90			90			90		
Link Speed (mph)		40			40			30			30	
Link Distance (ft)		841			2630			440			477	
Travel Time (s)		14.3			44.8			10.0			10.8	
Peak Hour Factor	0.94	0.94	0.94	0.94	0.94	0.94	0.94	0.94	0.94	0.94	0.94	0.94
Shared Lane Traffic (%)												
Sign Control		Stop			Stop			Stop			Stop	

Intersection Summary

Area Type: Other

Control Type: Unsignalized

Intersection	
Intersection Delay, s/veh	9.2
Intersection LOS	A



















Movement	EBL	EBT	EBR	WBL	WBT	WBR	NBL	NBT	NBR	SBL	SBT	SBR
Lane Configurations		↔↔	↔		↔↔	↔		↔	↔		↔	↔
Traffic Vol, veh/h	85	162	4	13	124	20	4	23	9	11	40	56
Future Vol, veh/h	85	162	4	13	124	20	4	23	9	11	40	56
Peak Hour Factor	0.94	0.94	0.94	0.94	0.94	0.94	0.94	0.94	0.94	0.94	0.94	0.94
Heavy Vehicles, %	2	2	2	2	2	2	2	2	2	2	2	2
Mvmt Flow	90	172	4	14	132	21	4	24	10	12	43	60
Number of Lanes	0	2	1	0	2	1	0	1	1	0	1	1

Approach	EB	WB	NB	SB
Opposing Approach	WB	EB	SB	NB
Opposing Lanes	3	3	2	2
Conflicting Approach Left	SB	NB	EB	WB
Conflicting Lanes Left	2	2	3	3
Conflicting Approach Right	NB	SB	WB	EB
Conflicting Lanes Right	2	2	3	3
HCM Control Delay	9.7	8.9	8.9	8.7
HCM LOS	A	A	A	A

Lane	NBLn1	NBLn2	EBLn1	EBLn2	EBLn3	WBLn1	WBLn2	WBLn3	SBLn1	SBLn2
Vol Left, %	15%	0%	61%	0%	0%	24%	0%	0%	22%	0%
Vol Thru, %	85%	0%	39%	100%	0%	76%	100%	0%	78%	0%
Vol Right, %	0%	100%	0%	0%	100%	0%	0%	100%	0%	100%
Sign Control	Stop	Stop	Stop	Stop	Stop	Stop	Stop	Stop	Stop	Stop
Traffic Vol by Lane	27	9	139	108	4	54	83	20	51	56
LT Vol	4	0	85	0	0	13	0	0	11	0
Through Vol	23	0	54	108	0	41	83	0	40	0
RT Vol	0	9	0	0	4	0	0	20	0	56
Lane Flow Rate	29	10	148	115	4	58	88	21	54	60
Geometry Grp	8	8	8	8	8	8	8	8	8	8
Degree of Util (X)	0.048	0.014	0.231	0.17	0.005	0.091	0.135	0.029	0.088	0.084
Departure Headway (Hd)	5.989	5.215	5.635	5.328	4.625	5.655	5.535	4.832	5.87	5.063
Convergence, Y/N	Yes	Yes	Yes	Yes	Yes	Yes	Yes	Yes	Yes	Yes
Cap	593	680	634	670	768	630	644	735	607	702
Service Time	3.773	2.999	3.399	3.092	2.388	3.421	3.301	2.598	3.641	2.834
HCM Lane V/C Ratio	0.049	0.015	0.233	0.172	0.005	0.092	0.137	0.029	0.089	0.085
HCM Control Delay	9.1	8.1	10.1	9.2	7.4	9	9.2	7.7	9.2	8.3
HCM Lane LOS	A	A	B	A	A	A	A	A	A	A
HCM 95th-tile Q	0.2	0	0.9	0.6	0	0.3	0.5	0.1	0.3	0.3

Lanes, Volumes, Timings  
3: Mt. Vernon Ave. & Main St.

Existing Conditions  
PM PEAK HOUR

												
Lane Group	EBL	EBT	EBR	WBL	WBT	WBR	NBL	NBT	NBR	SBL	SBT	SBR
Lane Configurations												
Traffic Volume (vph)	52	34	7	4	14	25	5	338	18	40	320	45
Future Volume (vph)	52	34	7	4	14	25	5	338	18	40	320	45
Ideal Flow (vphpl)	1900	1900	1900	1900	1900	1900	1900	1900	1900	1900	1900	1900
Storage Length (ft)	0		50	0		0	0		50	0		50
Storage Lanes	0		1	0		0	0		1	0		1
Taper Length (ft)	90			90			90			90		
Link Speed (mph)		40			40			40			40	
Link Distance (ft)		1252			1253			777			936	
Travel Time (s)		21.3			21.4			13.2			16.0	
Peak Hour Factor	0.84	0.84	0.84	0.84	0.84	0.84	0.84	0.84	0.84	0.84	0.84	0.84
Shared Lane Traffic (%)												
Sign Control		Stop			Stop			Stop			Stop	
<b>Intersection Summary</b>												
Area Type:	Other											
Control Type:	Unsignalized											

Intersection	
Intersection Delay, s/veh	16.8
Intersection LOS	C

Movement	EBL	EBT	EBR	WBL	WBT	WBR	NBL	NBT	NBR	SBL	SBT	SBR
Lane Configurations		↖	↗		↔			↖	↗		↖↗	↗
Traffic Vol, veh/h	52	34	7	4	14	25	5	338	18	40	320	45
Future Vol, veh/h	52	34	7	4	14	25	5	338	18	40	320	45
Peak Hour Factor	0.84	0.84	0.84	0.84	0.84	0.84	0.84	0.84	0.84	0.84	0.84	0.84
Heavy Vehicles, %	2	2	2	2	2	2	2	2	2	2	2	2
Mvmt Flow	62	40	8	5	17	30	6	402	21	48	381	54
Number of Lanes	0	1	1	0	1	0	0	1	1	0	2	1

Approach	EB	WB	NB	SB
Opposing Approach	WB	EB	SB	NB
Opposing Lanes	1	2	3	2
Conflicting Approach Left	SB	NB	EB	WB
Conflicting Lanes Left	3	2	2	1
Conflicting Approach Right	NB	SB	WB	EB
Conflicting Lanes Right	2	3	1	2
HCM Control Delay	12.5	10.9	23	12.9
HCM LOS	B	B	C	B

Lane	NBLn1	NBLn2	EBLn1	EBLn2	WBLn1	SBLn1	SBLn2	SBLn3
Vol Left, %	1%	0%	60%	0%	9%	27%	0%	0%
Vol Thru, %	99%	0%	40%	0%	33%	73%	100%	0%
Vol Right, %	0%	100%	0%	100%	58%	0%	0%	100%
Sign Control	Stop	Stop	Stop	Stop	Stop	Stop	Stop	Stop
Traffic Vol by Lane	343	18	86	7	43	147	213	45
LT Vol	5	0	52	0	4	40	0	0
Through Vol	338	0	34	0	14	107	213	0
RT Vol	0	18	0	7	25	0	0	45
Lane Flow Rate	408	21	102	8	51	175	254	54
Geometry Grp	8	8	8	8	8	8	8	8
Degree of Util (X)	0.719	0.033	0.22	0.016	0.105	0.314	0.446	0.084
Departure Headway (Hd)	6.337	5.622	7.72	6.703	7.365	6.467	6.329	5.62
Convergence, Y/N	Yes	Yes	Yes	Yes	Yes	Yes	Yes	Yes
Cap	568	633	462	530	489	553	566	633
Service Time	4.106	3.391	5.514	4.496	5.065	4.239	4.101	3.392
HCM Lane V/C Ratio	0.718	0.033	0.221	0.015	0.104	0.316	0.449	0.085
HCM Control Delay	23.8	8.6	12.7	9.6	10.9	12.2	14.2	8.9
HCM Lane LOS	C	A	B	A	B	B	B	A
HCM 95th-tile Q	5.9	0.1	0.8	0	0.3	1.3	2.3	0.3

Lanes, Volumes, Timings  
4: Mt. Vernon Ave. & Spring St.

Existing Conditions  
PM PEAK HOUR

Lane Group	EBL	EBT	EBR	WBL	WBT	WBR	NBL	NBT	NBR	SBL	SBT	SBR
Lane Configurations												
Traffic Volume (vph)	9	20	5	25	14	58	11	218	32	85	160	4
Future Volume (vph)	9	20	5	25	14	58	11	218	32	85	160	4
Ideal Flow (vphpl)	1900	1900	1900	1900	1900	1900	1900	1900	1900	1900	1900	1900
Storage Length (ft)	140		0	165		0	200		0	205		205
Storage Lanes	1		0	1		0	1		0	1		1
Taper Length (ft)	90			60			90			90		
Right Turn on Red			Yes			Yes			Yes			Yes
Link Speed (mph)		30			30			40			40	
Link Distance (ft)		549			688			569			394	
Travel Time (s)		12.5			15.6			9.7			6.7	
Peak Hour Factor	0.91	0.91	0.91	0.91	0.91	0.91	0.91	0.91	0.91	0.91	0.91	0.91
Shared Lane Traffic (%)												
Turn Type	Prot	NA		Prot	NA		Prot	NA		Prot	NA	Perm
Protected Phases	7	4		3	8		5	2		1	6	
Permitted Phases												6
Detector Phase	7	4		3	8		5	2		1	6	6
Switch Phase												
Minimum Initial (s)	4.0	4.0		4.0	4.0		4.0	4.0		4.0	4.0	4.0
Minimum Split (s)	8.0	22.0		8.0	22.0		8.0	22.0		8.0	22.0	22.0
Total Split (s)	8.0	22.0		8.0	22.0		8.0	22.0		8.0	22.0	22.0
Total Split (%)	13.3%	36.7%		13.3%	36.7%		13.3%	36.7%		13.3%	36.7%	36.7%
Yellow Time (s)	3.5	3.5		3.5	3.5		3.5	3.5		3.5	3.5	3.5
All-Red Time (s)	0.5	0.5		0.5	0.5		0.5	0.5		0.5	0.5	0.5
Lost Time Adjust (s)	0.0	0.0		0.0	0.0		0.0	0.0		0.0	0.0	0.0
Total Lost Time (s)	4.0	4.0		4.0	4.0		4.0	4.0		4.0	4.0	4.0
Lead/Lag	Lead	Lag		Lead	Lag		Lead	Lag		Lead	Lag	Lag
Lead-Lag Optimize?	Yes	Yes		Yes	Yes		Yes	Yes		Yes	Yes	Yes
Recall Mode	None	None		None	None		None	C-Max		None	C-Max	C-Max

Intersection Summary

Area Type: Other  
 Cycle Length: 60  
 Actuated Cycle Length: 60  
 Offset: 0 (0%), Referenced to phase 2:NBT and 6:SBT, Start of Yellow  
 Natural Cycle: 60  
 Control Type: Actuated-Coordinated

Splits and Phases: 4: Mt. Vernon Ave. & Spring St.

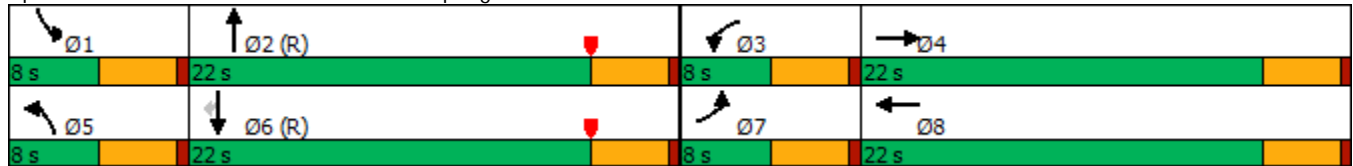

HCM 6th Signalized Intersection Summary  
4: Mt. Vernon Ave. & Spring St.

Existing Conditions  
PM PEAK HOUR

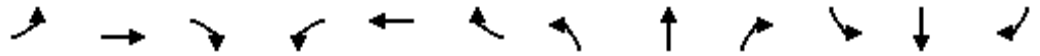

Movement	EBL	EBT	EBR	WBL	WBT	WBR	NBL	NBT	NBR	SBL	SBT	SBR
Lane Configurations												
Traffic Volume (veh/h)	9	20	5	25	14	58	11	218	32	85	160	4
Future Volume (veh/h)	9	20	5	25	14	58	11	218	32	85	160	4
Initial Q (Qb), veh	0	0	0	0	0	0	0	0	0	0	0	0
Ped-Bike Adj(A_pbT)	1.00		1.00	1.00		1.00	1.00		1.00	1.00		1.00
Parking Bus, Adj	1.00	1.00	1.00	1.00	1.00	1.00	1.00	1.00	1.00	1.00	1.00	1.00
Work Zone On Approach		No			No			No			No	
Adj Sat Flow, veh/h/ln	1870	1870	1870	1870	1870	1870	1870	1870	1870	1870	1870	1870
Adj Flow Rate, veh/h	10	22	5	27	15	64	12	240	35	93	176	4
Peak Hour Factor	0.91	0.91	0.91	0.91	0.91	0.91	0.91	0.91	0.91	0.91	0.91	0.91
Percent Heavy Veh, %	2	2	2	2	2	2	2	2	2	2	2	2
Cap, veh/h	18	91	21	43	23	100	22	1811	261	119	1189	1007
Arrive On Green	0.01	0.06	0.06	0.02	0.08	0.08	0.01	0.64	0.64	0.07	0.70	0.70
Sat Flow, veh/h	1781	1475	335	1781	310	1322	1781	3118	449	1781	1870	1585
Grp Volume(v), veh/h	10	0	27	27	0	79	12	135	140	93	176	4
Grp Sat Flow(s),veh/h/ln	1781	0	1810	1781	0	1632	1781	1777	1790	1781	1870	1585
Q Serve(g_s), s	0.3	0.0	0.9	0.9	0.0	2.8	0.4	1.8	1.8	3.1	1.9	0.0
Cycle Q Clear(g_c), s	0.3	0.0	0.9	0.9	0.0	2.8	0.4	1.8	1.8	3.1	1.9	0.0
Prop In Lane	1.00		0.19	1.00		0.81	1.00		0.25	1.00		1.00
Lane Grp Cap(c), veh/h	18	0	111	43	0	123	22	1032	1040	119	1189	1007
V/C Ratio(X)	0.55	0.00	0.24	0.63	0.00	0.64	0.56	0.13	0.13	0.78	0.15	0.00
Avail Cap(c_a), veh/h	119	0	543	119	0	490	119	1032	1040	119	1189	1007
HCM Platoon Ratio	1.00	1.00	1.00	1.00	1.00	1.00	1.10	1.10	1.10	1.10	1.10	1.10
Upstream Filter(I)	1.00	0.00	1.00	1.00	0.00	1.00	1.00	1.00	1.00	1.00	1.00	1.00
Uniform Delay (d), s/veh	29.6	0.0	26.8	29.0	0.0	26.9	29.4	4.9	4.9	27.4	3.6	3.3
Incr Delay (d2), s/veh	23.3	0.0	1.1	14.0	0.0	5.5	20.6	0.3	0.3	28.1	0.3	0.0
Initial Q Delay(d3),s/veh	0.0	0.0	0.0	0.0	0.0	0.0	0.0	0.0	0.0	0.0	0.0	0.0
%ile BackOfQ(50%),veh/ln	0.3	0.0	0.4	0.5	0.0	1.2	0.3	0.5	0.5	2.1	0.5	0.0
Unsig. Movement Delay, s/veh												
LnGrp Delay(d),s/veh	52.8	0.0	27.9	43.1	0.0	32.4	50.1	5.1	5.1	55.4	3.8	3.3
LnGrp LOS	D	A	C	D	A	C	D	A	A	E	A	A
Approach Vol, veh/h		37			106			287			273	
Approach Delay, s/veh		34.7			35.1			7.0			21.4	
Approach LOS		C			D			A			C	
Timer - Assigned Phs	1	2	3	4	5	6	7	8				
Phs Duration (G+Y+Rc), s	8.0	38.9	5.4	7.7	4.7	42.1	4.6	8.5				
Change Period (Y+Rc), s	4.0	4.0	4.0	4.0	4.0	4.0	4.0	4.0				
Max Green Setting (Gmax), s	4.0	18.0	4.0	18.0	4.0	18.0	4.0	18.0				
Max Q Clear Time (g_c+I1), s	5.1	3.8	2.9	2.9	2.4	3.9	2.3	4.8				
Green Ext Time (p_c), s	0.0	1.2	0.0	0.1	0.0	0.7	0.0	0.3				

Intersection Summary

HCM 6th Ctrl Delay	18.3
HCM 6th LOS	B

Notes

User approved pedestrian interval to be less than phase max green.

**APPENDIX D**

**EXISTING PLUS PROJECT (E+P) CONDITIONS  
INTERSECTION ANALYSIS CALCULATION WORKSHEETS**

THIS PAGE IS LEFT INTENTIONALLY BLANK

Lanes, Volumes, Timings  
1: Mt. Vernon Ave. & Center St.

E+P Conditions  
AM PEAK HOUR

Lane Group	EBL	EBT	EBR	WBL	WBT	WBR	NBL	NBT	NBR	SBL	SBT	SBR
Lane Configurations												
Traffic Volume (vph)	63	41	33	48	95	67	20	177	29	16	151	54
Future Volume (vph)	63	41	33	48	95	67	20	177	29	16	151	54
Ideal Flow (vphpl)	1900	1900	1900	1900	1900	1900	1900	1900	1900	1900	1900	1900
Storage Length (ft)	185		0	150		150	210		210	150		0
Storage Lanes	1		0	1		0	1		1	1		0
Taper Length (ft)	90			60			60			90		
Right Turn on Red			Yes			Yes			Yes			Yes
Link Speed (mph)		40			40			40			40	
Link Distance (ft)		2630			193			444			254	
Travel Time (s)		44.8			3.3			7.6			4.3	
Peak Hour Factor	0.85	0.85	0.85	0.85	0.85	0.85	0.85	0.85	0.85	0.85	0.85	0.85
Shared Lane Traffic (%)												
Turn Type	Prot	NA		Prot	NA		Prot	NA	Perm	Prot	NA	
Protected Phases	7	4		3	8		5	2		1	6	
Permitted Phases									2			
Detector Phase	7	4		3	8		5	2	2	1	6	
Switch Phase												
Minimum Initial (s)	4.0	4.0		4.0	4.0		4.0	4.0	4.0	4.0	4.0	
Minimum Split (s)	8.0	22.0		8.0	22.0		8.0	22.0	22.0	8.0	22.0	
Total Split (s)	8.0	22.0		8.0	22.0		8.0	22.0	22.0	8.0	22.0	
Total Split (%)	13.3%	36.7%		13.3%	36.7%		13.3%	36.7%	36.7%	13.3%	36.7%	
Yellow Time (s)	3.5	3.5		3.5	3.5		3.5	3.5	3.5	3.5	3.5	
All-Red Time (s)	0.5	0.5		0.5	0.5		0.5	0.5	0.5	0.5	0.5	
Lost Time Adjust (s)	0.0	0.0		0.0	0.0		0.0	0.0	0.0	0.0	0.0	
Total Lost Time (s)	4.0	4.0		4.0	4.0		4.0	4.0	4.0	4.0	4.0	
Lead/Lag	Lead	Lag		Lead	Lag		Lead	Lag	Lag	Lead	Lag	
Lead-Lag Optimize?	Yes	Yes		Yes	Yes		Yes	Yes	Yes	Yes	Yes	
Recall Mode	None	None		None	None		None	C-Max	C-Max	None	C-Max	

Intersection Summary

Area Type: Other  
 Cycle Length: 60  
 Actuated Cycle Length: 60  
 Offset: 0 (0%), Referenced to phase 2:NBT and 6:SBT, Start of Yellow  
 Natural Cycle: 60  
 Control Type: Actuated-Coordinated

Splits and Phases: 1: Mt. Vernon Ave. & Center St.

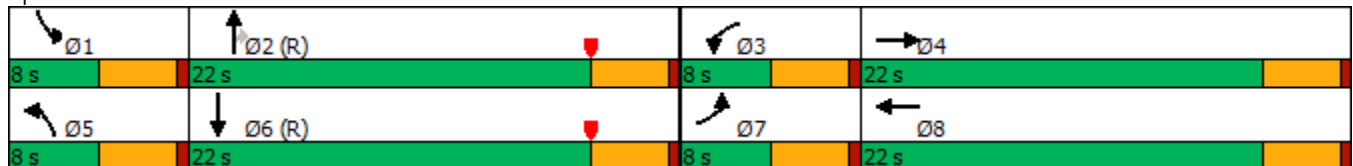

HCM 6th Signalized Intersection Summary  
 1: Mt. Vernon Ave. & Center St.

E+P Conditions  
 AM PEAK HOUR

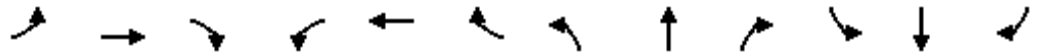

























Movement	EBL	EBT	EBR	WBL	WBT	WBR	NBL	NBT	NBR	SBL	SBT	SBR
Lane Configurations	↖	↗		↖	↗		↖	↑	↗	↖	↗	
Traffic Volume (veh/h)	63	41	33	48	95	67	20	177	29	16	151	54
Future Volume (veh/h)	63	41	33	48	95	67	20	177	29	16	151	54
Initial Q (Qb), veh	0	0	0	0	0	0	0	0	0	0	0	0
Ped-Bike Adj(A_pbT)	1.00		1.00	1.00		1.00	1.00		1.00	1.00		1.00
Parking Bus, Adj	1.00	1.00	1.00	1.00	1.00	1.00	1.00	1.00	1.00	1.00	1.00	1.00
Work Zone On Approach		No			No			No			No	
Adj Sat Flow, veh/h/ln	1870	1870	1870	1870	1870	1870	1870	1870	1870	1870	1870	1870
Adj Flow Rate, veh/h	74	48	39	56	112	79	24	208	34	19	178	64
Peak Hour Factor	0.85	0.85	0.85	0.85	0.85	0.85	0.85	0.85	0.85	0.85	0.85	0.85
Percent Heavy Veh, %	2	2	2	2	2	2	2	2	2	2	2	2
Cap, veh/h	94	222	162	72	208	136	39	1050	890	32	1442	501
Arrive On Green	0.05	0.11	0.11	0.04	0.10	0.10	0.02	0.56	0.56	0.02	0.56	0.56
Sat Flow, veh/h	1781	1961	1429	1781	2058	1347	1781	1870	1585	1781	2587	899
Grp Volume(v), veh/h	74	43	44	56	96	95	24	208	34	19	120	122
Grp Sat Flow(s),veh/h/ln	1781	1777	1613	1781	1777	1628	1781	1870	1585	1781	1777	1709
Q Serve(g_s), s	2.5	1.3	1.5	1.9	3.1	3.4	0.8	3.3	0.6	0.6	1.9	2.0
Cycle Q Clear(g_c), s	2.5	1.3	1.5	1.9	3.1	3.4	0.8	3.3	0.6	0.6	1.9	2.0
Prop In Lane	1.00		0.89	1.00		0.83	1.00		1.00	1.00		0.53
Lane Grp Cap(c), veh/h	94	201	183	72	180	165	39	1050	890	32	991	953
V/C Ratio(X)	0.79	0.21	0.24	0.78	0.53	0.58	0.61	0.20	0.04	0.59	0.12	0.13
Avail Cap(c_a), veh/h	119	533	484	119	533	488	119	1050	890	119	991	953
HCM Platoon Ratio	1.00	1.00	1.00	1.00	1.00	1.00	1.00	1.00	1.00	1.00	1.00	1.00
Upstream Filter(I)	1.00	1.00	1.00	1.00	1.00	1.00	1.00	1.00	1.00	1.00	1.00	1.00
Uniform Delay (d), s/veh	28.1	24.2	24.2	28.5	25.6	25.8	29.1	6.5	5.9	29.2	6.3	6.3
Incr Delay (d2), s/veh	23.4	0.5	0.7	16.2	2.4	3.2	14.5	0.4	0.1	15.9	0.3	0.3
Initial Q Delay(d3),s/veh	0.0	0.0	0.0	0.0	0.0	0.0	0.0	0.0	0.0	0.0	0.0	0.0
%ile BackOfQ(50%),veh/ln	1.6	0.5	0.6	1.1	1.3	1.3	0.5	1.1	0.2	0.4	0.6	0.6
Unsig. Movement Delay, s/veh												
LnGrp Delay(d),s/veh	51.5	24.7	24.9	44.7	28.1	29.0	43.6	6.9	6.0	45.2	6.5	6.6
LnGrp LOS	D	C	C	D	C	C	D	A	A	D	A	A
Approach Vol, veh/h		161			247			266			261	
Approach Delay, s/veh		37.1			32.2			10.1			9.4	
Approach LOS		D			C			B			A	
Timer - Assigned Phs	1	2	3	4	5	6	7	8				
Phs Duration (G+Y+Rc), s	5.1	37.7	6.4	10.8	5.3	37.5	7.2	10.1				
Change Period (Y+Rc), s	4.0	4.0	4.0	4.0	4.0	4.0	4.0	4.0				
Max Green Setting (Gmax), s	4.0	18.0	4.0	18.0	4.0	18.0	4.0	18.0				
Max Q Clear Time (g_c+I1), s	2.6	5.3	3.9	3.5	2.8	4.0	4.5	5.4				
Green Ext Time (p_c), s	0.0	0.9	0.0	0.3	0.0	1.0	0.0	0.7				

Intersection Summary												
HCM 6th Ctrl Delay				20.4								
HCM 6th LOS				C								

Lanes, Volumes, Timings  
2: Michigan Ave. & Center St.

E+P Conditions  
AM PEAK HOUR

												
Lane Group	EBL	EBT	EBR	WBL	WBT	WBR	NBL	NBT	NBR	SBL	SBT	SBR
Lane Configurations		 			 			 			 	
Traffic Volume (vph)	40	109	7	12	170	17	7	27	6	8	20	24
Future Volume (vph)	40	109	7	12	170	17	7	27	6	8	20	24
Ideal Flow (vphpl)	1900	1900	1900	1900	1900	1900	1900	1900	1900	1900	1900	1900
Storage Length (ft)	0		50	0		50	0		50	115		0
Storage Lanes	0		1	0		1	0		1	1		1
Taper Length (ft)	90			90			90			90		
Link Speed (mph)		40			40			30			30	
Link Distance (ft)		841			2630			440			477	
Travel Time (s)		14.3			44.8			10.0			10.8	
Peak Hour Factor	0.83	0.83	0.83	0.83	0.83	0.83	0.83	0.83	0.83	0.83	0.83	0.83
Shared Lane Traffic (%)												
Sign Control		Stop			Stop			Stop			Stop	
<b>Intersection Summary</b>												
Area Type:	Other											
Control Type:	Unsignalized											

Intersection	
Intersection Delay, s/veh	8.9
Intersection LOS	A



















Movement	EBL	EBT	EBR	WBL	WBT	WBR	NBL	NBT	NBR	SBL	SBT	SBR
Lane Configurations		↕↕	↗		↕↕	↗		↕	↗		↕	↗
Traffic Vol, veh/h	40	109	7	12	170	17	7	27	6	8	20	24
Future Vol, veh/h	40	109	7	12	170	17	7	27	6	8	20	24
Peak Hour Factor	0.83	0.83	0.83	0.83	0.83	0.83	0.83	0.83	0.83	0.83	0.83	0.83
Heavy Vehicles, %	2	2	2	2	2	2	2	2	2	2	2	2
Mvmt Flow	48	131	8	14	205	20	8	33	7	10	24	29
Number of Lanes	0	2	1	0	2	1	0	1	1	0	1	1

Approach	EB	WB	NB	SB
Opposing Approach	WB	EB	SB	NB
Opposing Lanes	3	3	2	2
Conflicting Approach Left	SB	NB	EB	WB
Conflicting Lanes Left	2	2	3	3
Conflicting Approach Right	NB	SB	WB	EB
Conflicting Lanes Right	2	2	3	3
HCM Control Delay	9	9	8.9	8.5
HCM LOS	A	A	A	A

Lane	NBLn1	NBLn2	EBLn1	EBLn2	EBLn3	WBLn1	WBLn2	WBLn3	SBLn1	SBLn2
Vol Left, %	21%	0%	52%	0%	0%	17%	0%	0%	29%	0%
Vol Thru, %	79%	0%	48%	100%	0%	83%	100%	0%	71%	0%
Vol Right, %	0%	100%	0%	0%	100%	0%	0%	100%	0%	100%
Sign Control	Stop	Stop	Stop	Stop	Stop	Stop	Stop	Stop	Stop	Stop
Traffic Vol by Lane	34	6	76	73	7	69	113	17	28	24
LT Vol	7	0	40	0	0	12	0	0	8	0
Through Vol	27	0	36	73	0	57	113	0	20	0
RT Vol	0	6	0	0	7	0	0	17	0	24
Lane Flow Rate	41	7	92	88	8	83	137	20	34	29
Geometry Grp	8	8	8	8	8	8	8	8	8	8
Degree of Util (X)	0.067	0.01	0.143	0.13	0.011	0.123	0.199	0.026	0.055	0.041
Departure Headway (Hd)	5.872	5.069	5.606	5.343	4.64	5.347	5.259	4.557	5.886	5.044
Convergence, Y/N	Yes	Yes	Yes	Yes	Yes	Yes	Yes	Yes	Yes	Yes
Cap	607	701	637	668	767	668	680	782	606	705
Service Time	3.639	2.837	3.36	3.097	2.394	3.097	3.009	2.306	3.651	2.809
HCM Lane V/C Ratio	0.068	0.01	0.144	0.132	0.01	0.124	0.201	0.026	0.056	0.041
HCM Control Delay	9.1	7.9	9.3	8.9	7.4	8.9	9.3	7.4	9	8
HCM Lane LOS	A	A	A	A	A	A	A	A	A	A
HCM 95th-tile Q	0.2	0	0.5	0.4	0	0.4	0.7	0.1	0.2	0.1

Lanes, Volumes, Timings  
3: Mt. Vernon Ave. & Main St.

E+P Conditions  
AM PEAK HOUR

												
Lane Group	EBL	EBT	EBR	WBL	WBT	WBR	NBL	NBT	NBR	SBL	SBT	SBR
Lane Configurations												
Traffic Volume (vph)	38	16	10	9	11	36	22	255	2	11	214	47
Future Volume (vph)	38	16	10	9	11	36	22	255	2	11	214	47
Ideal Flow (vphpl)	1900	1900	1900	1900	1900	1900	1900	1900	1900	1900	1900	1900
Storage Length (ft)	0		50	0		0	0		50	0		50
Storage Lanes	0		1	0		0	0		1	0		1
Taper Length (ft)	90			90			90			90		
Link Speed (mph)		40			40			40			40	
Link Distance (ft)		1252			1253			777			936	
Travel Time (s)		21.3			21.4			13.2			16.0	
Peak Hour Factor	0.88	0.88	0.88	0.88	0.88	0.88	0.88	0.88	0.88	0.88	0.88	0.88
Shared Lane Traffic (%)												
Sign Control		Stop			Stop			Stop			Stop	
<b>Intersection Summary</b>												
Area Type:	Other											
Control Type:	Unsignalized											

Intersection	
Intersection Delay, s/veh	11.7
Intersection LOS	B

Movement	EBL	EBT	EBR	WBL	WBT	WBR	NBL	NBT	NBR	SBL	SBT	SBR
Lane Configurations		↖	↗		↔			↖	↗		↖↗	↗
Traffic Vol, veh/h	38	16	10	9	11	36	22	255	2	11	214	47
Future Vol, veh/h	38	16	10	9	11	36	22	255	2	11	214	47
Peak Hour Factor	0.88	0.88	0.88	0.88	0.88	0.88	0.88	0.88	0.88	0.88	0.88	0.88
Heavy Vehicles, %	2	2	2	2	2	2	2	2	2	2	2	2
Mvmt Flow	43	18	11	10	13	41	25	290	2	13	243	53
Number of Lanes	0	1	1	0	1	0	0	1	1	0	2	1

Approach	EB	WB	NB	SB
Opposing Approach	WB	EB	SB	NB
Opposing Lanes	1	2	3	2
Conflicting Approach Left	SB	NB	EB	WB
Conflicting Lanes Left	3	2	2	1
Conflicting Approach Right	NB	SB	WB	EB
Conflicting Lanes Right	2	3	1	2
HCM Control Delay	10.3	9.7	14.2	9.9
HCM LOS	B	A	B	A

Lane	NBLn1	NBLn2	EBLn1	EBLn2	WBLn1	SBLn1	SBLn2	SBLn3
Vol Left, %	8%	0%	70%	0%	16%	13%	0%	0%
Vol Thru, %	92%	0%	30%	0%	20%	87%	100%	0%
Vol Right, %	0%	100%	0%	100%	64%	0%	0%	100%
Sign Control	Stop	Stop	Stop	Stop	Stop	Stop	Stop	Stop
Traffic Vol by Lane	277	2	54	10	56	82	143	47
LT Vol	22	0	38	0	9	11	0	0
Through Vol	255	0	16	0	11	71	143	0
RT Vol	0	2	0	10	36	0	0	47
Lane Flow Rate	315	2	61	11	64	94	162	53
Geometry Grp	8	8	8	8	8	8	8	8
Degree of Util (X)	0.504	0.003	0.118	0.018	0.11	0.153	0.262	0.076
Departure Headway (Hd)	5.765	5.02	6.898	5.838	6.21	5.876	5.808	5.102
Convergence, Y/N	Yes	Yes	Yes	Yes	Yes	Yes	Yes	Yes
Cap	626	713	520	613	577	611	619	703
Service Time	3.492	2.747	4.638	3.577	3.948	3.602	3.535	2.829
HCM Lane V/C Ratio	0.503	0.003	0.117	0.018	0.111	0.154	0.262	0.075
HCM Control Delay	14.2	7.8	10.6	8.7	9.7	9.7	10.6	8.3
HCM Lane LOS	B	A	B	A	A	A	B	A
HCM 95th-tile Q	2.8	0	0.4	0.1	0.4	0.5	1	0.2

Lanes, Volumes, Timings  
4: Mt. Vernon Ave. & Spring St.

E+P Conditions  
AM PEAK HOUR

Lane Group	EBL	EBT	EBR	WBL	WBT	WBR	NBL	NBT	NBR	SBL	SBT	SBR
Lane Configurations												
Traffic Volume (vph)	12	7	9	22	22	91	7	144	9	27	176	20
Future Volume (vph)	12	7	9	22	22	91	7	144	9	27	176	20
Ideal Flow (vphpl)	1900	1900	1900	1900	1900	1900	1900	1900	1900	1900	1900	1900
Storage Length (ft)	140		0	165		0	200		0	205		205
Storage Lanes	1		0	1		0	1		0	1		1
Taper Length (ft)	90			60			90			90		
Right Turn on Red			Yes			Yes			Yes			Yes
Link Speed (mph)		30			30			40			40	
Link Distance (ft)		549			688			569			394	
Travel Time (s)		12.5			15.6			9.7			6.7	
Peak Hour Factor	0.79	0.79	0.79	0.79	0.79	0.79	0.79	0.79	0.79	0.79	0.79	0.79
Shared Lane Traffic (%)												
Turn Type	Prot	NA		Prot	NA		Prot	NA		Prot	NA	Perm
Protected Phases	7	4		3	8		5	2		1	6	
Permitted Phases												6
Detector Phase	7	4		3	8		5	2		1	6	6
Switch Phase												
Minimum Initial (s)	4.0	4.0		4.0	4.0		4.0	4.0		4.0	4.0	4.0
Minimum Split (s)	8.0	22.0		8.0	22.0		8.0	22.0		8.0	22.0	22.0
Total Split (s)	8.0	22.0		8.0	22.0		8.0	22.0		8.0	22.0	22.0
Total Split (%)	13.3%	36.7%		13.3%	36.7%		13.3%	36.7%		13.3%	36.7%	36.7%
Yellow Time (s)	3.5	3.5		3.5	3.5		3.5	3.5		3.5	3.5	3.5
All-Red Time (s)	0.5	0.5		0.5	0.5		0.5	0.5		0.5	0.5	0.5
Lost Time Adjust (s)	0.0	0.0		0.0	0.0		0.0	0.0		0.0	0.0	0.0
Total Lost Time (s)	4.0	4.0		4.0	4.0		4.0	4.0		4.0	4.0	4.0
Lead/Lag	Lead	Lag		Lead	Lag		Lead	Lag		Lead	Lag	Lag
Lead-Lag Optimize?	Yes	Yes		Yes	Yes		Yes	Yes		Yes	Yes	Yes
Recall Mode	None	None		None	None		None	C-Max		None	C-Max	C-Max

Intersection Summary





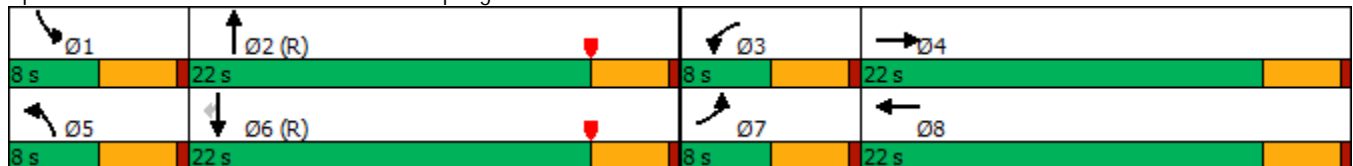

















Area Type: Other  
 Cycle Length: 60  
 Actuated Cycle Length: 60  
 Offset: 0 (0%), Referenced to phase 2:NBT and 6:SBT, Start of Yellow  
 Natural Cycle: 60  
 Control Type: Actuated-Coordinated

Splits and Phases: 4: Mt. Vernon Ave. & Spring St.



HCM 6th Signalized Intersection Summary  
4: Mt. Vernon Ave. & Spring St.

E+P Conditions  
AM PEAK HOUR

												
Movement	EBL	EBT	EBR	WBL	WBT	WBR	NBL	NBT	NBR	SBL	SBT	SBR
Lane Configurations												
Traffic Volume (veh/h)	12	7	9	22	22	91	7	144	9	27	176	20
Future Volume (veh/h)	12	7	9	22	22	91	7	144	9	27	176	20
Initial Q (Qb), veh	0	0	0	0	0	0	0	0	0	0	0	0
Ped-Bike Adj(A_pbT)	1.00		1.00	1.00		1.00	1.00		1.00	1.00		1.00
Parking Bus, Adj	1.00	1.00	1.00	1.00	1.00	1.00	1.00	1.00	1.00	1.00	1.00	1.00
Work Zone On Approach		No			No			No			No	
Adj Sat Flow, veh/h/ln	1870	1870	1870	1870	1870	1870	1870	1870	1870	1870	1870	1870
Adj Flow Rate, veh/h	15	9	11	28	28	115	9	182	11	34	223	25
Peak Hour Factor	0.79	0.79	0.79	0.79	0.79	0.79	0.79	0.79	0.79	0.79	0.79	0.79
Percent Heavy Veh, %	2	2	2	2	2	2	2	2	2	2	2	2
Cap, veh/h	26	85	104	44	39	159	17	1937	116	51	1100	932
Arrive On Green	0.01	0.11	0.11	0.02	0.12	0.12	0.01	0.57	0.57	0.03	0.59	0.59
Sat Flow, veh/h	1781	766	936	1781	320	1314	1781	3406	204	1781	1870	1585
Grp Volume(v), veh/h	15	0	20	28	0	143	9	94	99	34	223	25
Grp Sat Flow(s),veh/h/ln	1781	0	1702	1781	0	1634	1781	1777	1834	1781	1870	1585
Q Serve(g_s), s	0.5	0.0	0.6	0.9	0.0	5.1	0.3	1.5	1.5	1.1	3.3	0.4
Cycle Q Clear(g_c), s	0.5	0.0	0.6	0.9	0.0	5.1	0.3	1.5	1.5	1.1	3.3	0.4
Prop In Lane	1.00		0.55	1.00		0.80	1.00		0.11	1.00		1.00
Lane Grp Cap(c), veh/h	26	0	189	44	0	198	17	1010	1043	51	1100	932
V/C Ratio(X)	0.57	0.00	0.11	0.63	0.00	0.72	0.54	0.09	0.09	0.66	0.20	0.03
Avail Cap(c_a), veh/h	119	0	511	119	0	490	119	1010	1043	119	1100	932
HCM Platoon Ratio	1.00	1.00	1.00	1.00	1.00	1.00	1.00	1.00	1.00	1.00	1.00	1.00
Upstream Filter(I)	1.00	0.00	1.00	1.00	0.00	1.00	1.00	1.00	1.00	1.00	1.00	1.00
Uniform Delay (d), s/veh	29.4	0.0	24.0	29.0	0.0	25.4	29.6	5.9	5.9	28.8	5.8	5.2
Incr Delay (d2), s/veh	18.0	0.0	0.2	13.9	0.0	4.9	25.0	0.2	0.2	13.6	0.4	0.1
Initial Q Delay(d3),s/veh	0.0	0.0	0.0	0.0	0.0	0.0	0.0	0.0	0.0	0.0	0.0	0.0
%ile BackOfQ(50%),veh/ln	0.3	0.0	0.3	0.6	0.0	2.1	0.2	0.4	0.4	0.6	1.0	0.1
Unsig. Movement Delay, s/veh												
LnGrp Delay(d),s/veh	47.4	0.0	24.2	42.9	0.0	30.3	54.6	6.1	6.1	42.4	6.2	5.2
LnGrp LOS	D	A	C	D	A	C	D	A	A	D	A	A
Approach Vol, veh/h		35			171			202			282	
Approach Delay, s/veh		34.2			32.4			8.2			10.5	
Approach LOS		C			C			A			B	
Timer - Assigned Phs	1	2	3	4	5	6	7	8				
Phs Duration (G+Y+Rc), s	5.7	38.1	5.5	10.7	4.6	39.3	4.9	11.3				
Change Period (Y+Rc), s	4.0	4.0	4.0	4.0	4.0	4.0	4.0	4.0				
Max Green Setting (Gmax), s	4.0	18.0	4.0	18.0	4.0	18.0	4.0	18.0				
Max Q Clear Time (g_c+I1), s	3.1	3.5	2.9	2.6	2.3	5.3	2.5	7.1				
Green Ext Time (p_c), s	0.0	0.8	0.0	0.0	0.0	0.9	0.0	0.5				
<b>Intersection Summary</b>												
HCM 6th Ctrl Delay			16.5									
HCM 6th LOS			B									

Lanes, Volumes, Timings  
 5: Mt. Vernon Ave. & Project Dwy. 1

E+P Conditions  
 AM PEAK HOUR



Lane Group	WBL	WBR	NBT	NBR	SBL	SBT
Lane Configurations						
Traffic Volume (vph)	44	39	245	52	33	178
Future Volume (vph)	44	39	245	52	33	178
Ideal Flow (vphpl)	1900	1900	1900	1900	1900	1900
Link Speed (mph)	30		40			40
Link Distance (ft)	206		287			777
Travel Time (s)	4.7		4.9			13.2
Peak Hour Factor	0.92	0.92	0.92	0.92	0.92	0.92
Shared Lane Traffic (%)						
Sign Control	Stop		Free			Free

Intersection Summary

Area Type: Other  
 Control Type: Unsignalized

Intersection						
Int Delay, s/veh	2.1					
Movement	WBL	WBR	NBT	NBR	SBL	SBT
Lane Configurations	Y <sup>Y</sup>		T <sup>T</sup>			↑↑
Traffic Vol, veh/h	44	39	245	52	33	178
Future Vol, veh/h	44	39	245	52	33	178
Conflicting Peds, #/hr	0	0	0	0	0	0
Sign Control	Stop	Stop	Free	Free	Free	Free
RT Channelized	-	None	-	None	-	None
Storage Length	0	-	-	-	-	-
Veh in Median Storage, #	0	-	0	-	-	0
Grade, %	0	-	0	-	-	0
Peak Hour Factor	92	92	92	92	92	92
Heavy Vehicles, %	2	2	2	2	2	2
Mvmt Flow	48	42	266	57	36	193

Major/Minor	Minor1	Major1	Major2		
Conflicting Flow All	464	295	0	0	323
Stage 1	295	-	-	-	-
Stage 2	169	-	-	-	-
Critical Hdwy	6.63	6.23	-	-	4.13
Critical Hdwy Stg 1	5.43	-	-	-	-
Critical Hdwy Stg 2	5.83	-	-	-	-
Follow-up Hdwy	3.519	3.319	-	-	2.219
Pot Cap-1 Maneuver	541	744	-	-	1235
Stage 1	755	-	-	-	-
Stage 2	844	-	-	-	-
Platoon blocked, %			-	-	-
Mov Cap-1 Maneuver	523	744	-	-	1235
Mov Cap-2 Maneuver	523	-	-	-	-
Stage 1	730	-	-	-	-
Stage 2	844	-	-	-	-

Approach	WB	NB	SB
HCM Control Delay, s	12	0	1.3
HCM LOS	B		

Minor Lane/Major Mvmt	NBT	NBRWBLn1	SBL	SBT
Capacity (veh/h)	-	-	608	1235
HCM Lane V/C Ratio	-	-	0.148	0.029
HCM Control Delay (s)	-	-	12	8
HCM Lane LOS	-	-	B	A
HCM 95th %tile Q(veh)	-	-	0.5	0.1

Lanes, Volumes, Timings  
6: Mt. Vernon Ave. & Project Dwy. 2

E+P Conditions  
AM PEAK HOUR



Lane Group	WBL	WBR	NBT	NBR	SBL	SBT
Lane Configurations						
Traffic Volume (vph)	0	29	268	39	0	222
Future Volume (vph)	0	29	268	39	0	222
Ideal Flow (vphpl)	1900	1900	1900	1900	1900	1900
Link Speed (mph)	30		40			40
Link Distance (ft)	217		254			287
Travel Time (s)	4.9		4.3			4.9
Peak Hour Factor	0.92	0.92	0.92	0.92	0.92	0.92
Shared Lane Traffic (%)						
Sign Control	Stop		Free			Free

Intersection Summary

Area Type: Other  
Control Type: Unsignalized

Intersection						
Int Delay, s/veh	0.5					
Movement	WBL	WBR	NBT	NBR	SBL	SBT
Lane Configurations		↗	↘			↕↕
Traffic Vol, veh/h	0	29	268	39	0	222
Future Vol, veh/h	0	29	268	39	0	222
Conflicting Peds, #/hr	0	0	0	0	0	0
Sign Control	Stop	Stop	Free	Free	Free	Free
RT Channelized	-	None	-	None	-	None
Storage Length	-	0	-	-	-	-
Veh in Median Storage, #	0	-	0	-	-	0
Grade, %	0	-	0	-	-	0
Peak Hour Factor	92	92	92	92	92	92
Heavy Vehicles, %	2	2	2	2	2	2
Mvmt Flow	0	32	291	42	0	241

Major/Minor	Minor1	Major1	Major2
Conflicting Flow All	-	312	0
Stage 1	-	-	-
Stage 2	-	-	-
Critical Hdwy	-	6.23	-
Critical Hdwy Stg 1	-	-	-
Critical Hdwy Stg 2	-	-	-
Follow-up Hdwy	-	3.319	-
Pot Cap-1 Maneuver	0	727	-
Stage 1	0	-	-
Stage 2	0	-	-
Platoon blocked, %		-	-
Mov Cap-1 Maneuver	-	727	-
Mov Cap-2 Maneuver	-	-	-
Stage 1	-	-	-
Stage 2	-	-	-

Approach	WB	NB	SB
HCM Control Delay, s	10.2	0	0
HCM LOS	B		

Minor Lane/Major Mvmt	NBT	NBRWBLn1	SBT
Capacity (veh/h)	-	-	727
HCM Lane V/C Ratio	-	-	0.043
HCM Control Delay (s)	-	-	10.2
HCM Lane LOS	-	-	B
HCM 95th %tile Q(veh)	-	-	0.1

Lanes, Volumes, Timings  
 7: Center St. & Project Dwy. 3

E+P Conditions  
 AM PEAK HOUR

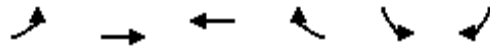

Lane Group	EBL	EBT	WBT	WBR	SBL	SBR
Lane Configurations		↑	↑			↑
Traffic Volume (vph)	0	86	195	7	0	16
Future Volume (vph)	0	86	195	7	0	16
Ideal Flow (vphpl)	1900	1900	1900	1900	1900	1900
Link Speed (mph)		40	40		30	
Link Distance (ft)		105	264		189	
Travel Time (s)		1.8	4.5		4.3	
Peak Hour Factor	0.92	0.92	0.92	0.92	0.92	0.92
Shared Lane Traffic (%)						
Sign Control		Free	Free		Stop	

Intersection Summary

Area Type: Other  
 Control Type: Unsignalized

Intersection						
Int Delay, s/veh	0.5					
Movement	EBL	EBT	WBT	WBR	SBL	SBR
Lane Configurations		↑	↑			↑
Traffic Vol, veh/h	0	86	195	7	0	16
Future Vol, veh/h	0	86	195	7	0	16
Conflicting Peds, #/hr	0	0	0	0	0	0
Sign Control	Free	Free	Free	Free	Stop	Stop
RT Channelized	-	None	-	None	-	None
Storage Length	-	-	-	-	-	0
Veh in Median Storage, #	-	0	0	-	0	-
Grade, %	-	0	0	-	0	-
Peak Hour Factor	92	92	92	92	92	92
Heavy Vehicles, %	2	2	2	2	2	2
Mvmt Flow	0	93	212	8	0	17

Major/Minor	Major1	Major2	Minor2
Conflicting Flow All	-	0	-
Stage 1	-	-	-
Stage 2	-	-	-
Critical Hdwy	-	-	-
Critical Hdwy Stg 1	-	-	-
Critical Hdwy Stg 2	-	-	-
Follow-up Hdwy	-	-	-
Pot Cap-1 Maneuver	0	-	-
Stage 1	0	-	-
Stage 2	0	-	-
Platoon blocked, %	-	-	-
Mov Cap-1 Maneuver	-	-	-
Mov Cap-2 Maneuver	-	-	-
Stage 1	-	-	-
Stage 2	-	-	-

Approach	EB	WB	SB
HCM Control Delay, s	0	0	9.5
HCM LOS			A

Minor Lane/Major Mvmt	EBT	WBT	WBR	SBLn1
Capacity (veh/h)	-	-	-	824
HCM Lane V/C Ratio	-	-	-	0.021
HCM Control Delay (s)	-	-	-	9.5
HCM Lane LOS	-	-	-	A
HCM 95th %tile Q(veh)	-	-	-	0.1

Lanes, Volumes, Timings  
 8: Center St. & Project Dwy. 4

E+P Conditions  
 AM PEAK HOUR



Lane Group	EBL	EBT	WBT	WBR	SBL	SBR
Lane Configurations		↑	↑		↑	
Traffic Volume (vph)	10	76	174	1	1	28
Future Volume (vph)	10	76	174	1	1	28
Ideal Flow (vphpl)	1900	1900	1900	1900	1900	1900
Link Speed (mph)		40	40		30	
Link Distance (ft)		264	515		187	
Travel Time (s)		4.5	8.8		4.3	
Peak Hour Factor	0.92	0.92	0.92	0.92	0.92	0.92
Shared Lane Traffic (%)						
Sign Control		Free	Free		Stop	

Intersection Summary

Area Type: Other  
 Control Type: Unsignalized

**Intersection**

Int Delay, s/veh 1.2

**Movement** EBL EBT WBT WBR SBL SBR

Lane Configurations		↑	↑		↑	
Traffic Vol, veh/h	10	76	174	1	1	28
Future Vol, veh/h	10	76	174	1	1	28
Conflicting Peds, #/hr	0	0	0	0	0	0
Sign Control	Free	Free	Free	Free	Stop	Stop
RT Channelized	-	None	-	None	-	None
Storage Length	-	-	-	-	0	-
Veh in Median Storage, #	-	0	0	-	0	-
Grade, %	-	0	0	-	0	-
Peak Hour Factor	92	92	92	92	92	92
Heavy Vehicles, %	2	2	2	2	2	2
Mvmt Flow	11	83	189	1	1	30

**Major/Minor** Major1 Major2 Minor2

Conflicting Flow All	190	0	-	0	295	190
Stage 1	-	-	-	-	190	-
Stage 2	-	-	-	-	105	-
Critical Hdwy	4.12	-	-	-	6.42	6.22
Critical Hdwy Stg 1	-	-	-	-	5.42	-
Critical Hdwy Stg 2	-	-	-	-	5.42	-
Follow-up Hdwy	2.218	-	-	-	3.518	3.318
Pot Cap-1 Maneuver	1384	-	-	-	696	852
Stage 1	-	-	-	-	842	-
Stage 2	-	-	-	-	919	-
Platoon blocked, %		-	-	-		
Mov Cap-1 Maneuver	1384	-	-	-	690	852
Mov Cap-2 Maneuver	-	-	-	-	690	-
Stage 1	-	-	-	-	835	-
Stage 2	-	-	-	-	919	-

**Approach** EB WB SB

HCM Control Delay, s	0.9	0	9.4
HCM LOS			A

**Minor Lane/Major Mvmt** EBL EBT WBT WBR SBLn1

Capacity (veh/h)	1384	-	-	-	845
HCM Lane V/C Ratio	0.008	-	-	-	0.037
HCM Control Delay (s)	7.6	-	-	-	9.4
HCM Lane LOS	A	-	-	-	A
HCM 95th %tile Q(veh)	0	-	-	-	0.1

Lanes, Volumes, Timings  
1: Mt. Vernon Ave. & Center St.

E+P Conditions  
PM PEAK HOUR

Lane Group	EBL	EBT	EBR	WBL	WBT	WBR	NBL	NBT	NBR	SBL	SBT	SBR
Lane Configurations												
Traffic Volume (vph)	99	63	18	25	56	39	16	260	17	54	218	88
Future Volume (vph)	99	63	18	25	56	39	16	260	17	54	218	88
Ideal Flow (vphpl)	1900	1900	1900	1900	1900	1900	1900	1900	1900	1900	1900	1900
Storage Length (ft)	185		0	150		150	210		210	150		0
Storage Lanes	1		0	1		0	1		1	1		0
Taper Length (ft)	90			60			60			90		
Right Turn on Red			Yes			Yes			Yes			Yes
Link Speed (mph)		40			40			40			40	
Link Distance (ft)		2630			193			444			254	
Travel Time (s)		44.8			3.3			7.6			4.3	
Peak Hour Factor	0.90	0.90	0.90	0.90	0.90	0.90	0.90	0.90	0.90	0.90	0.90	0.90
Shared Lane Traffic (%)												
Turn Type	Prot	NA		Prot	NA		Prot	NA	Perm	Prot	NA	
Protected Phases	7	4		3	8		5	2		1	6	
Permitted Phases									2			
Detector Phase	7	4		3	8		5	2	2	1	6	
Switch Phase												
Minimum Initial (s)	4.0	4.0		4.0	4.0		4.0	4.0	4.0	4.0	4.0	
Minimum Split (s)	8.0	22.0		8.0	22.0		8.0	22.0	22.0	8.0	22.0	
Total Split (s)	8.0	22.0		8.0	22.0		8.0	22.0	22.0	8.0	22.0	
Total Split (%)	13.3%	36.7%		13.3%	36.7%		13.3%	36.7%	36.7%	13.3%	36.7%	
Yellow Time (s)	3.5	3.5		3.5	3.5		3.5	3.5	3.5	3.5	3.5	
All-Red Time (s)	0.5	0.5		0.5	0.5		0.5	0.5	0.5	0.5	0.5	
Lost Time Adjust (s)	0.0	0.0		0.0	0.0		0.0	0.0	0.0	0.0	0.0	
Total Lost Time (s)	4.0	4.0		4.0	4.0		4.0	4.0	4.0	4.0	4.0	
Lead/Lag	Lead	Lag		Lead	Lag		Lead	Lag	Lag	Lead	Lag	
Lead-Lag Optimize?	Yes	Yes		Yes	Yes		Yes	Yes	Yes	Yes	Yes	
Recall Mode	None	None		None	None		None	C-Max	C-Max	None	C-Max	

Intersection Summary





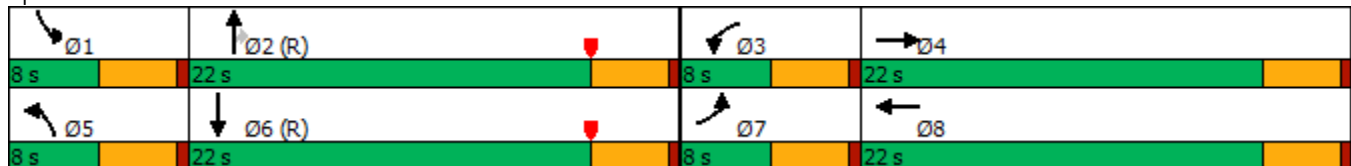

















Area Type: Other  
 Cycle Length: 60  
 Actuated Cycle Length: 60  
 Offset: 0 (0%), Referenced to phase 2:NBT and 6:SBT, Start of Yellow  
 Natural Cycle: 60  
 Control Type: Actuated-Coordinated

Splits and Phases: 1: Mt. Vernon Ave. & Center St.



























HCM 6th Signalized Intersection Summary  
 1: Mt. Vernon Ave. & Center St.

E+P Conditions  
 PM PEAK HOUR

												
Movement	EBL	EBT	EBR	WBL	WBT	WBR	NBL	NBT	NBR	SBL	SBT	SBR
Lane Configurations												
Traffic Volume (veh/h)	99	63	18	25	56	39	16	260	17	54	218	88
Future Volume (veh/h)	99	63	18	25	56	39	16	260	17	54	218	88
Initial Q (Qb), veh	0	0	0	0	0	0	0	0	0	0	0	0
Ped-Bike Adj(A_pbT)	1.00		1.00	1.00		1.00	1.00		1.00	1.00		1.00
Parking Bus, Adj	1.00	1.00	1.00	1.00	1.00	1.00	1.00	1.00	1.00	1.00	1.00	1.00
Work Zone On Approach		No			No			No			No	
Adj Sat Flow, veh/h/ln	1870	1870	1870	1870	1870	1870	1870	1870	1870	1870	1870	1870
Adj Flow Rate, veh/h	110	70	20	28	62	43	18	289	19	60	242	98
Peak Hour Factor	0.90	0.90	0.90	0.90	0.90	0.90	0.90	0.90	0.90	0.90	0.90	0.90
Percent Heavy Veh, %	2	2	2	2	2	2	2	2	2	2	2	2
Cap, veh/h	119	305	84	44	144	91	31	1039	881	75	1446	569
Arrive On Green	0.07	0.11	0.11	0.02	0.07	0.07	0.02	0.56	0.56	0.04	0.58	0.58
Sat Flow, veh/h	1781	2754	757	1781	2087	1322	1781	1870	1585	1781	2491	980
Grp Volume(v), veh/h	110	44	46	28	52	53	18	289	19	60	171	169
Grp Sat Flow(s),veh/h/ln	1781	1777	1734	1781	1777	1632	1781	1870	1585	1781	1777	1694
Q Serve(g_s), s	3.7	1.4	1.4	0.9	1.7	1.9	0.6	4.9	0.3	2.0	2.7	2.8
Cycle Q Clear(g_c), s	3.7	1.4	1.4	0.9	1.7	1.9	0.6	4.9	0.3	2.0	2.7	2.8
Prop In Lane	1.00		0.44	1.00		0.81	1.00		1.00	1.00		0.58
Lane Grp Cap(c), veh/h	119	196	192	44	122	112	31	1039	881	75	1032	984
V/C Ratio(X)	0.93	0.22	0.24	0.63	0.42	0.47	0.58	0.28	0.02	0.80	0.17	0.17
Avail Cap(c_a), veh/h	119	533	520	119	533	490	119	1039	881	119	1032	984
HCM Platoon Ratio	1.00	1.00	1.00	1.00	1.00	1.00	1.00	1.00	1.00	1.00	1.00	1.00
Upstream Filter(I)	1.00	1.00	1.00	1.00	1.00	1.00	1.00	1.00	1.00	1.00	1.00	1.00
Uniform Delay (d), s/veh	27.9	24.3	24.4	29.0	26.8	26.9	29.3	7.0	6.0	28.5	5.8	5.9
Incr Delay (d2), s/veh	60.0	0.6	0.6	13.9	2.3	3.1	16.4	0.7	0.0	17.8	0.3	0.4
Initial Q Delay(d3),s/veh	0.0	0.0	0.0	0.0	0.0	0.0	0.0	0.0	0.0	0.0	0.0	0.0
%ile BackOfQ(50%),veh/ln	3.4	0.6	0.6	0.5	0.7	0.8	0.4	1.6	0.1	1.2	0.8	0.8
Unsig. Movement Delay, s/veh												
LnGrp Delay(d),s/veh	87.8	24.9	25.0	42.9	29.1	30.0	45.6	7.7	6.0	46.3	6.2	6.2
LnGrp LOS	F	C	C	D	C	C	D	A	A	D	A	A
Approach Vol, veh/h		200			133			326			400	
Approach Delay, s/veh		59.5			32.4			9.7			12.2	
Approach LOS		E			C			A			B	
Timer - Assigned Phs	1	2	3	4	5	6	7	8				
Phs Duration (G+Y+Rc), s	6.5	37.3	5.5	10.6	5.0	38.8	8.0	8.1				
Change Period (Y+Rc), s	4.0	4.0	4.0	4.0	4.0	4.0	4.0	4.0				
Max Green Setting (Gmax), s	4.0	18.0	4.0	18.0	4.0	18.0	4.0	18.0				
Max Q Clear Time (g_c+I1), s	4.0	6.9	2.9	3.4	2.6	4.8	5.7	3.9				
Green Ext Time (p_c), s	0.0	1.2	0.0	0.3	0.0	1.5	0.0	0.4				
<b>Intersection Summary</b>												
HCM 6th Ctrl Delay				22.9								
HCM 6th LOS				C								

Lanes, Volumes, Timings  
2: Michigan Ave. & Center St.

E+P Conditions  
PM PEAK HOUR

												
Lane Group	EBL	EBT	EBR	WBL	WBT	WBR	NBL	NBT	NBR	SBL	SBT	SBR
Lane Configurations		 			 			 			 	
Traffic Volume (vph)	85	189	4	21	148	28	4	23	18	20	40	56
Future Volume (vph)	85	189	4	21	148	28	4	23	18	20	40	56
Ideal Flow (vphpl)	1900	1900	1900	1900	1900	1900	1900	1900	1900	1900	1900	1900
Storage Length (ft)	0		50	0		50	0		50	115		0
Storage Lanes	0		1	0		1	0		1	1		1
Taper Length (ft)	90			90			90			90		
Link Speed (mph)		40			40			30			30	
Link Distance (ft)		841			2630			440			477	
Travel Time (s)		14.3			44.8			10.0			10.8	
Peak Hour Factor	0.94	0.94	0.94	0.94	0.94	0.94	0.94	0.94	0.94	0.94	0.94	0.94
Shared Lane Traffic (%)												
Sign Control		Stop			Stop			Stop			Stop	
<b>Intersection Summary</b>												
Area Type:	Other											
Control Type:	Unsignalized											

Intersection	
Intersection Delay, s/veh	9.6
Intersection LOS	A



















Movement	EBL	EBT	EBR	WBL	WBT	WBR	NBL	NBT	NBR	SBL	SBT	SBR
Lane Configurations		↔↔	↔		↔↔	↔		↔	↔		↔	↔
Traffic Vol, veh/h	85	189	4	21	148	28	4	23	18	20	40	56
Future Vol, veh/h	85	189	4	21	148	28	4	23	18	20	40	56
Peak Hour Factor	0.94	0.94	0.94	0.94	0.94	0.94	0.94	0.94	0.94	0.94	0.94	0.94
Heavy Vehicles, %	2	2	2	2	2	2	2	2	2	2	2	2
Mvmt Flow	90	201	4	22	157	30	4	24	19	21	43	60
Number of Lanes	0	2	1	0	2	1	0	1	1	0	1	1

Approach	EB	WB	NB	SB
Opposing Approach	WB	EB	SB	NB
Opposing Lanes	3	3	2	2
Conflicting Approach Left	SB	NB	EB	WB
Conflicting Lanes Left	2	2	3	3
Conflicting Approach Right	NB	SB	WB	EB
Conflicting Lanes Right	2	2	3	3
HCM Control Delay	10.1	9.3	9	9.2
HCM LOS	B	A	A	A

Lane	NBLn1	NBLn2	EBLn1	EBLn2	EBLn3	WBLn1	WBLn2	WBLn3	SBLn1	SBLn2
Vol Left, %	15%	0%	57%	0%	0%	30%	0%	0%	33%	0%
Vol Thru, %	85%	0%	43%	100%	0%	70%	100%	0%	67%	0%
Vol Right, %	0%	100%	0%	0%	100%	0%	0%	100%	0%	100%
Sign Control	Stop	Stop	Stop	Stop	Stop	Stop	Stop	Stop	Stop	Stop
Traffic Vol by Lane	27	18	148	126	4	70	99	28	60	56
LT Vol	4	0	85	0	0	21	0	0	20	0
Through Vol	23	0	63	126	0	49	99	0	40	0
RT Vol	0	18	0	0	4	0	0	28	0	56
Lane Flow Rate	29	19	157	134	4	75	105	30	64	60
Geometry Grp	8	8	8	8	8	8	8	8	8	8
Degree of Util (X)	0.05	0.029	0.253	0.204	0.006	0.121	0.165	0.041	0.109	0.087
Departure Headway (Hd)	6.32	5.545	5.775	5.486	4.782	5.816	5.666	4.962	6.136	5.27
Convergence, Y/N	Yes	Yes	Yes	Yes	Yes	Yes	Yes	Yes	Yes	Yes
Cap	570	650	617	647	739	610	627	713	578	671
Service Time	4.02	3.245	3.562	3.273	2.569	3.611	3.461	2.756	3.935	3.069
HCM Lane V/C Ratio	0.051	0.029	0.254	0.207	0.005	0.123	0.167	0.042	0.111	0.089
HCM Control Delay	9.4	8.4	10.5	9.7	7.6	9.4	9.6	8	9.7	8.6
HCM Lane LOS	A	A	B	A	A	A	A	A	A	A
HCM 95th-tile Q	0.2	0.1	1	0.8	0	0.4	0.6	0.1	0.4	0.3

Lanes, Volumes, Timings  
3: Mt. Vernon Ave. & Main St.

E+P Conditions  
PM PEAK HOUR

												
Lane Group	EBL	EBT	EBR	WBL	WBT	WBR	NBL	NBT	NBR	SBL	SBT	SBR
Lane Configurations												
Traffic Volume (vph)	52	34	12	4	14	25	9	354	18	40	338	45
Future Volume (vph)	52	34	12	4	14	25	9	354	18	40	338	45
Ideal Flow (vphpl)	1900	1900	1900	1900	1900	1900	1900	1900	1900	1900	1900	1900
Storage Length (ft)	0		50	0		0	0		50	0		50
Storage Lanes	0		1	0		0	0		1	0		1
Taper Length (ft)	90			90			90			90		
Link Speed (mph)		40			40			40			40	
Link Distance (ft)		1252			1253			777			936	
Travel Time (s)		21.3			21.4			13.2			16.0	
Peak Hour Factor	0.84	0.84	0.84	0.84	0.84	0.84	0.84	0.84	0.84	0.84	0.84	0.84
Shared Lane Traffic (%)												
Sign Control		Stop			Stop			Stop			Stop	
<b>Intersection Summary</b>												
Area Type:	Other											
Control Type:	Unsignalized											

Intersection	
Intersection Delay, s/veh	18.8
Intersection LOS	C

Movement	EBL	EBT	EBR	WBL	WBT	WBR	NBL	NBT	NBR	SBL	SBT	SBR
Lane Configurations		↖	↗		↔			↖	↗		↖↗	↗
Traffic Vol, veh/h	52	34	12	4	14	25	9	354	18	40	338	45
Future Vol, veh/h	52	34	12	4	14	25	9	354	18	40	338	45
Peak Hour Factor	0.84	0.84	0.84	0.84	0.84	0.84	0.84	0.84	0.84	0.84	0.84	0.84
Heavy Vehicles, %	2	2	2	2	2	2	2	2	2	2	2	2
Mvmt Flow	62	40	14	5	17	30	11	421	21	48	402	54
Number of Lanes	0	1	1	0	1	0	0	1	1	0	2	1

Approach	EB	WB	NB	SB
Opposing Approach	WB	EB	SB	NB
Opposing Lanes	1	2	3	2
Conflicting Approach Left	SB	NB	EB	WB
Conflicting Lanes Left	3	2	2	1
Conflicting Approach Right	NB	SB	WB	EB
Conflicting Lanes Right	2	3	1	2
HCM Control Delay	12.6	11.2	27	13.6
HCM LOS	B	B	D	B

Lane	NBLn1	NBLn2	EBLn1	EBLn2	WBLn1	SBLn1	SBLn2	SBLn3
Vol Left, %	2%	0%	60%	0%	9%	26%	0%	0%
Vol Thru, %	98%	0%	40%	0%	33%	74%	100%	0%
Vol Right, %	0%	100%	0%	100%	58%	0%	0%	100%
Sign Control	Stop	Stop	Stop	Stop	Stop	Stop	Stop	Stop
Traffic Vol by Lane	363	18	86	12	43	153	225	45
LT Vol	9	0	52	0	4	40	0	0
Through Vol	354	0	34	0	14	113	225	0
RT Vol	0	18	0	12	25	0	0	45
Lane Flow Rate	432	21	102	14	51	182	268	54
Geometry Grp	8	8	8	8	8	8	8	8
Degree of Util (X)	0.772	0.034	0.227	0.028	0.107	0.332	0.48	0.085
Departure Headway (Hd)	6.435	5.715	7.981	6.961	7.556	6.572	6.44	5.731
Convergence, Y/N	Yes	Yes	Yes	Yes	Yes	Yes	Yes	Yes
Cap	557	621	453	517	477	543	555	620
Service Time	4.217	3.496	5.683	4.663	5.263	4.357	4.224	3.515
HCM Lane V/C Ratio	0.776	0.034	0.225	0.027	0.107	0.335	0.483	0.087
HCM Control Delay	27.9	8.7	13	9.9	11.2	12.6	15.1	9.1
HCM Lane LOS	D	A	B	A	B	B	C	A
HCM 95th-tile Q	7	0.1	0.9	0.1	0.4	1.4	2.6	0.3

Lanes, Volumes, Timings  
4: Mt. Vernon Ave. & Spring St.

E+P Conditions  
PM PEAK HOUR

Lane Group	EBL	EBT	EBR	WBL	WBT	WBR	NBL	NBT	NBR	SBL	SBT	SBR
Lane Configurations												
Traffic Volume (vph)	14	20	5	25	14	58	11	232	32	85	172	8
Future Volume (vph)	14	20	5	25	14	58	11	232	32	85	172	8
Ideal Flow (vphpl)	1900	1900	1900	1900	1900	1900	1900	1900	1900	1900	1900	1900
Storage Length (ft)	140		0	165		0	200		0	205		205
Storage Lanes	1		0	1		0	1		0	1		1
Taper Length (ft)	90			60			90			90		
Right Turn on Red			Yes			Yes			Yes			Yes
Link Speed (mph)		30			30			40			40	
Link Distance (ft)		549			688			569			394	
Travel Time (s)		12.5			15.6			9.7			6.7	
Peak Hour Factor	0.91	0.91	0.91	0.91	0.91	0.91	0.91	0.91	0.91	0.91	0.91	0.91
Shared Lane Traffic (%)												
Turn Type	Prot	NA		Prot	NA		Prot	NA		Prot	NA	Perm
Protected Phases	7	4		3	8		5	2		1	6	
Permitted Phases												6
Detector Phase	7	4		3	8		5	2		1	6	6
Switch Phase												
Minimum Initial (s)	4.0	4.0		4.0	4.0		4.0	4.0		4.0	4.0	4.0
Minimum Split (s)	8.0	22.0		8.0	22.0		8.0	22.0		8.0	22.0	22.0
Total Split (s)	8.0	22.0		8.0	22.0		8.0	22.0		8.0	22.0	22.0
Total Split (%)	13.3%	36.7%		13.3%	36.7%		13.3%	36.7%		13.3%	36.7%	36.7%
Yellow Time (s)	3.5	3.5		3.5	3.5		3.5	3.5		3.5	3.5	3.5
All-Red Time (s)	0.5	0.5		0.5	0.5		0.5	0.5		0.5	0.5	0.5
Lost Time Adjust (s)	0.0	0.0		0.0	0.0		0.0	0.0		0.0	0.0	0.0
Total Lost Time (s)	4.0	4.0		4.0	4.0		4.0	4.0		4.0	4.0	4.0
Lead/Lag	Lead	Lag		Lead	Lag		Lead	Lag		Lead	Lag	Lag
Lead-Lag Optimize?	Yes	Yes		Yes	Yes		Yes	Yes		Yes	Yes	Yes
Recall Mode	None	None		None	None		None	C-Max		None	C-Max	C-Max

Intersection Summary

Area Type: Other  
 Cycle Length: 60  
 Actuated Cycle Length: 60  
 Offset: 0 (0%), Referenced to phase 2:NBT and 6:SBT, Start of Yellow  
 Natural Cycle: 60  
 Control Type: Actuated-Coordinated

Splits and Phases: 4: Mt. Vernon Ave. & Spring St.

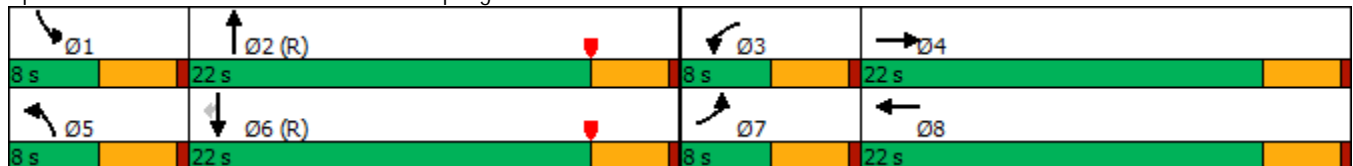

HCM 6th Signalized Intersection Summary  
4: Mt. Vernon Ave. & Spring St.

E+P Conditions  
PM PEAK HOUR



Movement	EBL	EBT	EBR	WBL	WBT	WBR	NBL	NBT	NBR	SBL	SBT	SBR
Lane Configurations												
Traffic Volume (veh/h)	14	20	5	25	14	58	11	232	32	85	172	8
Future Volume (veh/h)	14	20	5	25	14	58	11	232	32	85	172	8
Initial Q (Qb), veh	0	0	0	0	0	0	0	0	0	0	0	0
Ped-Bike Adj(A_pbT)	1.00		1.00	1.00		1.00	1.00		1.00	1.00		1.00
Parking Bus, Adj	1.00	1.00	1.00	1.00	1.00	1.00	1.00	1.00	1.00	1.00	1.00	1.00
Work Zone On Approach		No			No			No			No	
Adj Sat Flow, veh/h/ln	1870	1870	1870	1870	1870	1870	1870	1870	1870	1870	1870	1870
Adj Flow Rate, veh/h	15	22	5	27	15	64	12	255	35	93	189	9
Peak Hour Factor	0.91	0.91	0.91	0.91	0.91	0.91	0.91	0.91	0.91	0.91	0.91	0.91
Percent Heavy Veh, %	2	2	2	2	2	2	2	2	2	2	2	2
Cap, veh/h	26	97	22	43	23	100	22	1812	246	119	1180	1000
Arrive On Green	0.01	0.07	0.07	0.02	0.08	0.08	0.01	0.58	0.58	0.07	0.63	0.63
Sat Flow, veh/h	1781	1475	335	1781	310	1322	1781	3144	427	1781	1870	1585
Grp Volume(v), veh/h	15	0	27	27	0	79	12	143	147	93	189	9
Grp Sat Flow(s),veh/h/ln	1781	0	1810	1781	0	1632	1781	1777	1794	1781	1870	1585
Q Serve(g_s), s	0.5	0.0	0.8	0.9	0.0	2.8	0.4	2.2	2.3	3.1	2.5	0.1
Cycle Q Clear(g_c), s	0.5	0.0	0.8	0.9	0.0	2.8	0.4	2.2	2.3	3.1	2.5	0.1
Prop In Lane	1.00		0.19	1.00		0.81	1.00		0.24	1.00		1.00
Lane Grp Cap(c), veh/h	26	0	120	43	0	123	22	1024	1034	119	1180	1000
V/C Ratio(X)	0.57	0.00	0.23	0.63	0.00	0.64	0.56	0.14	0.14	0.78	0.16	0.01
Avail Cap(c_a), veh/h	119	0	543	119	0	490	119	1024	1034	119	1180	1000
HCM Platoon Ratio	1.00	1.00	1.00	1.00	1.00	1.00	1.00	1.00	1.00	1.00	1.00	1.00
Upstream Filter(I)	1.00	0.00	1.00	1.00	0.00	1.00	1.00	1.00	1.00	1.00	1.00	1.00
Uniform Delay (d), s/veh	29.4	0.0	26.6	29.0	0.0	26.9	29.5	5.9	5.9	27.6	4.5	4.1
Incr Delay (d2), s/veh	18.0	0.0	0.9	14.0	0.0	5.5	20.6	0.3	0.3	28.1	0.3	0.0
Initial Q Delay(d3),s/veh	0.0	0.0	0.0	0.0	0.0	0.0	0.0	0.0	0.0	0.0	0.0	0.0
%ile BackOfQ(50%),veh/ln	0.3	0.0	0.4	0.5	0.0	1.2	0.3	0.7	0.7	2.1	0.7	0.0
Unsig. Movement Delay, s/veh												
LnGrp Delay(d),s/veh	47.4	0.0	27.5	43.1	0.0	32.4	50.1	6.1	6.2	55.6	4.8	4.1
LnGrp LOS	D	A	C	D	A	C	D	A	A	E	A	A
Approach Vol, veh/h		42			106			302			291	
Approach Delay, s/veh		34.6			35.1			7.9			21.0	
Approach LOS		C			D			A			C	
Timer - Assigned Phs	1	2	3	4	5	6	7	8				
Phs Duration (G+Y+Rc), s	8.0	38.6	5.4	8.0	4.7	41.9	4.9	8.5				
Change Period (Y+Rc), s	4.0	4.0	4.0	4.0	4.0	4.0	4.0	4.0				
Max Green Setting (Gmax), s	4.0	18.0	4.0	18.0	4.0	18.0	4.0	18.0				
Max Q Clear Time (g_c+I1), s	5.1	4.3	2.9	2.8	2.4	4.5	2.5	4.8				
Green Ext Time (p_c), s	0.0	1.2	0.0	0.1	0.0	0.7	0.0	0.3				

Intersection Summary

HCM 6th Ctrl Delay	18.5
HCM 6th LOS	B

Notes

User approved pedestrian interval to be less than phase max green.

Lanes, Volumes, Timings  
 5: Mt. Vernon Ave. & Project Dwy. 1

E+P Conditions  
 PM PEAK HOUR



Lane Group	WBL	WBR	NBT	NBR	SBL	SBT
Lane Configurations						
Traffic Volume (vph)	54	47	325	61	39	306
Future Volume (vph)	54	47	325	61	39	306
Ideal Flow (vphpl)	1900	1900	1900	1900	1900	1900
Link Speed (mph)	30		40			40
Link Distance (ft)	206		287			777
Travel Time (s)	4.7		4.9			13.2
Peak Hour Factor	0.92	0.92	0.92	0.92	0.92	0.92
Shared Lane Traffic (%)						
Sign Control	Stop		Free			Free

Intersection Summary

Area Type: Other  
 Control Type: Unsignalized

Intersection						
Int Delay, s/veh	2.1					
Movement	WBL	WBR	NBT	NBR	SBL	SBT
Lane Configurations	Y		T			↑↑
Traffic Vol, veh/h	54	47	325	61	39	306
Future Vol, veh/h	54	47	325	61	39	306
Conflicting Peds, #/hr	0	0	0	0	0	0
Sign Control	Stop	Stop	Free	Free	Free	Free
RT Channelized	-	None	-	None	-	None
Storage Length	0	-	-	-	-	-
Veh in Median Storage, #	0	-	0	-	-	0
Grade, %	0	-	0	-	-	0
Peak Hour Factor	92	92	92	92	92	92
Heavy Vehicles, %	2	2	2	2	2	2
Mvmt Flow	59	51	353	66	42	333

Major/Minor	Minor1	Major1	Major2		
Conflicting Flow All	637	386	0	0	419
Stage 1	386	-	-	-	-
Stage 2	251	-	-	-	-
Critical Hdwy	6.63	6.23	-	-	4.13
Critical Hdwy Stg 1	5.43	-	-	-	-
Critical Hdwy Stg 2	5.83	-	-	-	-
Follow-up Hdwy	3.519	3.319	-	-	2.219
Pot Cap-1 Maneuver	425	661	-	-	1138
Stage 1	686	-	-	-	-
Stage 2	768	-	-	-	-
Platoon blocked, %			-	-	-
Mov Cap-1 Maneuver	406	661	-	-	1138
Mov Cap-2 Maneuver	406	-	-	-	-
Stage 1	655	-	-	-	-
Stage 2	768	-	-	-	-

Approach	WB	NB	SB
HCM Control Delay, s	14.3	0	0.9
HCM LOS	B		

Minor Lane/Major Mvmt	NBT	NBRWBLn1	SBL	SBT
Capacity (veh/h)	-	-	495	1138
HCM Lane V/C Ratio	-	-	0.222	0.037
HCM Control Delay (s)	-	-	14.3	8.3
HCM Lane LOS	-	-	B	A
HCM 95th %tile Q(veh)	-	-	0.8	0.1

Lanes, Volumes, Timings  
 6: Mt. Vernon Ave. & Project Dwy. 2

E+P Conditions  
 PM PEAK HOUR



Lane Group	WBL	WBR	NBT	NBR	SBL	SBT
Lane Configurations						
Traffic Volume (vph)	0	35	351	46	0	360
Future Volume (vph)	0	35	351	46	0	360
Ideal Flow (vphpl)	1900	1900	1900	1900	1900	1900
Link Speed (mph)	30		40			40
Link Distance (ft)	217		254			287
Travel Time (s)	4.9		4.3			4.9
Peak Hour Factor	0.92	0.92	0.92	0.92	0.92	0.92
Shared Lane Traffic (%)						
Sign Control	Stop		Free			Free

Intersection Summary

Area Type: Other  
 Control Type: Unsignalized

Intersection						
Int Delay, s/veh	0.5					
Movement	WBL	WBR	NBT	NBR	SBL	SBT
Lane Configurations		↗	↘			↕↕
Traffic Vol, veh/h	0	35	351	46	0	360
Future Vol, veh/h	0	35	351	46	0	360
Conflicting Peds, #/hr	0	0	0	0	0	0
Sign Control	Stop	Stop	Free	Free	Free	Free
RT Channelized	-	None	-	None	-	None
Storage Length	-	0	-	-	-	-
Veh in Median Storage, #	0	-	0	-	-	0
Grade, %	0	-	0	-	-	0
Peak Hour Factor	92	92	92	92	92	92
Heavy Vehicles, %	2	2	2	2	2	2
Mvmt Flow	0	38	382	50	0	391

Major/Minor	Minor1	Major1	Major2		
Conflicting Flow All	-	407	0	0	-
Stage 1	-	-	-	-	-
Stage 2	-	-	-	-	-
Critical Hdwy	-	6.23	-	-	-
Critical Hdwy Stg 1	-	-	-	-	-
Critical Hdwy Stg 2	-	-	-	-	-
Follow-up Hdwy	-	3.319	-	-	-
Pot Cap-1 Maneuver	0	643	-	-	0
Stage 1	0	-	-	-	0
Stage 2	0	-	-	-	0
Platoon blocked, %			-	-	-
Mov Cap-1 Maneuver	-	643	-	-	-
Mov Cap-2 Maneuver	-	-	-	-	-
Stage 1	-	-	-	-	-
Stage 2	-	-	-	-	-

Approach	WB	NB	SB
HCM Control Delay, s	11	0	0
HCM LOS	B		

Minor Lane/Major Mvmt	NBT	NBRWBLn1	SBT
Capacity (veh/h)	-	-	643
HCM Lane V/C Ratio	-	-	0.059
HCM Control Delay (s)	-	-	11
HCM Lane LOS	-	-	B
HCM 95th %tile Q(veh)	-	-	0.2

Lanes, Volumes, Timings  
 7: Center St. & Project Dwy. 3

E+P Conditions  
 PM PEAK HOUR

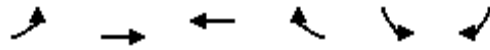

Lane Group	EBL	EBT	WBT	WBR	SBL	SBR
Lane Configurations		↑	↔			↗
Traffic Volume (vph)	0	134	99	8	0	20
Future Volume (vph)	0	134	99	8	0	20
Ideal Flow (vphpl)	1900	1900	1900	1900	1900	1900
Link Speed (mph)		40	40		30	
Link Distance (ft)		105	264		189	
Travel Time (s)		1.8	4.5		4.3	
Peak Hour Factor	0.92	0.92	0.92	0.92	0.92	0.92
Shared Lane Traffic (%)						
Sign Control		Free	Free		Stop	

Intersection Summary

Area Type: Other  
 Control Type: Unsignalized

**Intersection**

Int Delay, s/veh 0.7

**Movement** EBL EBT WBT WBR SBL SBR

Lane Configurations		↑	↑			↑
Traffic Vol, veh/h	0	134	99	8	0	20
Future Vol, veh/h	0	134	99	8	0	20
Conflicting Peds, #/hr	0	0	0	0	0	0
Sign Control	Free	Free	Free	Free	Stop	Stop
RT Channelized	-	None	-	None	-	None
Storage Length	-	-	-	-	-	0
Veh in Median Storage, #	-	0	0	-	0	-
Grade, %	-	0	0	-	0	-
Peak Hour Factor	92	92	92	92	92	92
Heavy Vehicles, %	2	2	2	2	2	2
Mvmt Flow	0	146	108	9	0	22

**Major/Minor** Major1 Major2 Minor2

Conflicting Flow All	-	0	-	0	-	113
Stage 1	-	-	-	-	-	-
Stage 2	-	-	-	-	-	-
Critical Hdwy	-	-	-	-	-	6.22
Critical Hdwy Stg 1	-	-	-	-	-	-
Critical Hdwy Stg 2	-	-	-	-	-	-
Follow-up Hdwy	-	-	-	-	-	3.318
Pot Cap-1 Maneuver	0	-	-	-	0	940
Stage 1	0	-	-	-	0	-
Stage 2	0	-	-	-	0	-
Platoon blocked, %		-	-	-		
Mov Cap-1 Maneuver	-	-	-	-	-	940
Mov Cap-2 Maneuver	-	-	-	-	-	-
Stage 1	-	-	-	-	-	-
Stage 2	-	-	-	-	-	-

**Approach** EB WB SB

HCM Control Delay, s	0	0	8.9
HCM LOS			A

**Minor Lane/Major Mvmt** EBT WBT WBR SBLn1

Capacity (veh/h)	-	-	-	940
HCM Lane V/C Ratio	-	-	-	0.023
HCM Control Delay (s)	-	-	-	8.9
HCM Lane LOS	-	-	-	A
HCM 95th %tile Q(veh)	-	-	-	0.1

Lanes, Volumes, Timings  
 8: Center St. & Project Dwy. 4

E+P Conditions  
 PM PEAK HOUR

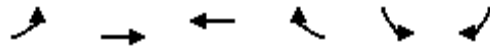

Lane Group	EBL	EBT	WBT	WBR	SBL	SBR
Lane Configurations		↑	↑		↑	
Traffic Volume (vph)	30	104	89	2	1	18
Future Volume (vph)	30	104	89	2	1	18
Ideal Flow (vphpl)	1900	1900	1900	1900	1900	1900
Link Speed (mph)		40	40		30	
Link Distance (ft)		264	515		187	
Travel Time (s)		4.5	8.8		4.3	
Peak Hour Factor	0.92	0.92	0.92	0.92	0.92	0.92
Shared Lane Traffic (%)						
Sign Control		Free	Free		Stop	

Intersection Summary

Area Type: Other  
 Control Type: Unsignalized

**Intersection**

Int Delay, s/veh 1.6

**Movement** EBL EBT WBT WBR SBL SBR

Lane Configurations		↑	↑		↑	
Traffic Vol, veh/h	30	104	89	2	1	18
Future Vol, veh/h	30	104	89	2	1	18
Conflicting Peds, #/hr	0	0	0	0	0	0
Sign Control	Free	Free	Free	Free	Stop	Stop
RT Channelized	-	None	-	None	-	None
Storage Length	-	-	-	-	0	-
Veh in Median Storage, #	-	0	0	-	0	-
Grade, %	-	0	0	-	0	-
Peak Hour Factor	92	92	92	92	92	92
Heavy Vehicles, %	2	2	2	2	2	2
Mvmt Flow	33	113	97	2	1	20

**Major/Minor** Major1 Major2 Minor2

Conflicting Flow All	99	0	-	0	277	98
Stage 1	-	-	-	-	98	-
Stage 2	-	-	-	-	179	-
Critical Hdwy	4.12	-	-	-	6.42	6.22
Critical Hdwy Stg 1	-	-	-	-	5.42	-
Critical Hdwy Stg 2	-	-	-	-	5.42	-
Follow-up Hdwy	2.218	-	-	-	3.518	3.318
Pot Cap-1 Maneuver	1494	-	-	-	713	958
Stage 1	-	-	-	-	926	-
Stage 2	-	-	-	-	852	-
Platoon blocked, %		-	-	-		
Mov Cap-1 Maneuver	1494	-	-	-	696	958
Mov Cap-2 Maneuver	-	-	-	-	696	-
Stage 1	-	-	-	-	904	-
Stage 2	-	-	-	-	852	-

**Approach** EB WB SB

HCM Control Delay, s 1.7 0 8.9  
HCM LOS A

**Minor Lane/Major Mvmt** EBL EBT WBT WBR SBLn1

Capacity (veh/h)	1494	-	-	-	939
HCM Lane V/C Ratio	0.022	-	-	-	0.022
HCM Control Delay (s)	7.5	-	-	-	8.9
HCM Lane LOS	A	-	-	-	A
HCM 95th %tile Q(veh)	0.1	-	-	-	0.1

## **APPENDIX E**

**EXISTING PLUS AMBIENT PLUS PROJECT (E+A+P 2022) CONDITIONS  
INTERSECTION ANALYSIS CALCULATION WORKSHEETS**

THIS PAGE IS LEFT INTENTIONALLY BLANK

Lanes, Volumes, Timings  
1: Mt. Vernon Ave. & Center St.

EAP (2022) Conditions  
AM PEAK HOUR

Lane Group	EBL	EBT	EBR	WBL	WBT	WBR	NBL	NBT	NBR	SBL	SBT	SBR
Lane Configurations												
Traffic Volume (vph)	65	42	34	50	98	69	21	184	30	16	157	56
Future Volume (vph)	65	42	34	50	98	69	21	184	30	16	157	56
Ideal Flow (vphpl)	1900	1900	1900	1900	1900	1900	1900	1900	1900	1900	1900	1900
Storage Length (ft)	185		0	150		150	210		210	150		0
Storage Lanes	1		0	1		0	1		1	1		0
Taper Length (ft)	90			60			60			90		
Right Turn on Red			Yes			Yes			Yes			Yes
Link Speed (mph)		40			40			40			40	
Link Distance (ft)		2630			193			444			254	
Travel Time (s)		44.8			3.3			7.6			4.3	
Peak Hour Factor	0.85	0.85	0.85	0.85	0.85	0.85	0.85	0.85	0.85	0.85	0.85	0.85
Shared Lane Traffic (%)												
Turn Type	Prot	NA		Prot	NA		Prot	NA	Perm	Prot	NA	
Protected Phases	7	4		3	8		5	2		1	6	
Permitted Phases									2			
Detector Phase	7	4		3	8		5	2	2	1	6	
Switch Phase												
Minimum Initial (s)	4.0	4.0		4.0	4.0		4.0	4.0	4.0	4.0	4.0	
Minimum Split (s)	8.0	22.0		8.0	22.0		8.0	22.0	22.0	8.0	22.0	
Total Split (s)	8.0	22.0		8.0	22.0		8.0	22.0	22.0	8.0	22.0	
Total Split (%)	13.3%	36.7%		13.3%	36.7%		13.3%	36.7%	36.7%	13.3%	36.7%	
Yellow Time (s)	3.5	3.5		3.5	3.5		3.5	3.5	3.5	3.5	3.5	
All-Red Time (s)	0.5	0.5		0.5	0.5		0.5	0.5	0.5	0.5	0.5	
Lost Time Adjust (s)	0.0	0.0		0.0	0.0		0.0	0.0	0.0	0.0	0.0	
Total Lost Time (s)	4.0	4.0		4.0	4.0		4.0	4.0	4.0	4.0	4.0	
Lead/Lag	Lead	Lag		Lead	Lag		Lead	Lag	Lag	Lead	Lag	
Lead-Lag Optimize?	Yes	Yes		Yes	Yes		Yes	Yes	Yes	Yes	Yes	
Recall Mode	None	None		None	None		None	C-Max	C-Max	None	C-Max	

Intersection Summary





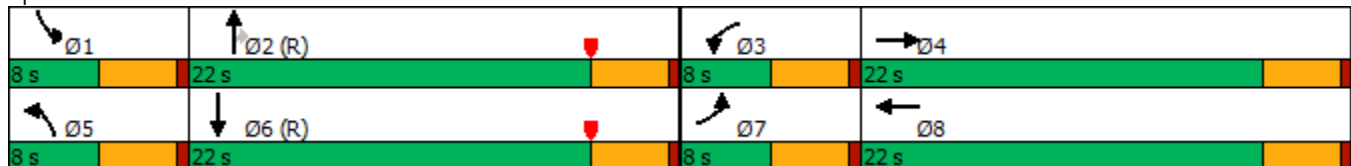

















Area Type: Other  
 Cycle Length: 60  
 Actuated Cycle Length: 60  
 Offset: 0 (0%), Referenced to phase 2:NBT and 6:SBT, Start of Yellow  
 Natural Cycle: 60  
 Control Type: Actuated-Coordinated

Splits and Phases: 1: Mt. Vernon Ave. & Center St.



























HCM 6th Signalized Intersection Summary  
 1: Mt. Vernon Ave. & Center St.

EAP (2022) Conditions  
 AM PEAK HOUR

												
Movement	EBL	EBT	EBR	WBL	WBT	WBR	NBL	NBT	NBR	SBL	SBT	SBR
Lane Configurations												
Traffic Volume (veh/h)	65	42	34	50	98	69	21	184	30	16	157	56
Future Volume (veh/h)	65	42	34	50	98	69	21	184	30	16	157	56
Initial Q (Qb), veh	0	0	0	0	0	0	0	0	0	0	0	0
Ped-Bike Adj(A_pbT)	1.00		1.00	1.00		1.00	1.00		1.00	1.00		1.00
Parking Bus, Adj	1.00	1.00	1.00	1.00	1.00	1.00	1.00	1.00	1.00	1.00	1.00	1.00
Work Zone On Approach		No			No			No			No	
Adj Sat Flow, veh/h/ln	1870	1870	1870	1870	1870	1870	1870	1870	1870	1870	1870	1870
Adj Flow Rate, veh/h	76	49	40	59	115	81	25	216	35	19	185	66
Peak Hour Factor	0.85	0.85	0.85	0.85	0.85	0.85	0.85	0.85	0.85	0.85	0.85	0.85
Percent Heavy Veh, %	2	2	2	2	2	2	2	2	2	2	2	2
Cap, veh/h	97	226	165	74	212	139	40	1044	885	32	1435	495
Arrive On Green	0.05	0.12	0.12	0.04	0.10	0.10	0.02	0.56	0.56	0.02	0.55	0.55
Sat Flow, veh/h	1781	1957	1432	1781	2058	1346	1781	1870	1585	1781	2592	895
Grp Volume(v), veh/h	76	44	45	59	98	98	25	216	35	19	125	126
Grp Sat Flow(s),veh/h/ln	1781	1777	1613	1781	1777	1628	1781	1870	1585	1781	1777	1709
Q Serve(g_s), s	2.5	1.3	1.5	2.0	3.1	3.4	0.8	3.5	0.6	0.6	2.0	2.1
Cycle Q Clear(g_c), s	2.5	1.3	1.5	2.0	3.1	3.4	0.8	3.5	0.6	0.6	2.0	2.1
Prop In Lane	1.00		0.89	1.00		0.83	1.00		1.00	1.00		0.52
Lane Grp Cap(c), veh/h	97	205	186	74	183	167	40	1044	885	32	984	946
V/C Ratio(X)	0.79	0.21	0.24	0.79	0.54	0.58	0.62	0.21	0.04	0.59	0.13	0.13
Avail Cap(c_a), veh/h	119	533	484	119	533	488	119	1044	885	119	984	946
HCM Platoon Ratio	1.00	1.00	1.00	1.00	1.00	1.00	1.00	1.00	1.00	1.00	1.00	1.00
Upstream Filter(I)	1.00	1.00	1.00	1.00	1.00	1.00	1.00	1.00	1.00	1.00	1.00	1.00
Uniform Delay (d), s/veh	28.0	24.1	24.2	28.5	25.6	25.7	29.1	6.6	6.0	29.2	6.4	6.5
Incr Delay (d2), s/veh	24.0	0.5	0.7	17.0	2.4	3.2	14.3	0.4	0.1	15.9	0.3	0.3
Initial Q Delay(d3),s/veh	0.0	0.0	0.0	0.0	0.0	0.0	0.0	0.0	0.0	0.0	0.0	0.0
%ile BackOfQ(50%),veh/ln	1.6	0.5	0.6	1.1	1.3	1.4	0.5	1.1	0.2	0.4	0.6	0.6
Unsig. Movement Delay, s/veh												
LnGrp Delay(d),s/veh	52.0	24.6	24.8	45.5	28.0	28.9	43.4	7.1	6.1	45.2	6.7	6.7
LnGrp LOS	D	C	C	D	C	C	D	A	A	D	A	A
Approach Vol, veh/h		165			255			276			270	
Approach Delay, s/veh		37.3			32.4			10.2			9.4	
Approach LOS		D			C			B			A	
Timer - Assigned Phs	1	2	3	4	5	6	7	8				
Phs Duration (G+Y+Rc), s	5.1	37.5	6.5	10.9	5.4	37.2	7.3	10.2				
Change Period (Y+Rc), s	4.0	4.0	4.0	4.0	4.0	4.0	4.0	4.0				
Max Green Setting (Gmax), s	4.0	18.0	4.0	18.0	4.0	18.0	4.0	18.0				
Max Q Clear Time (g_c+I1), s	2.6	5.5	4.0	3.5	2.8	4.1	4.5	5.4				
Green Ext Time (p_c), s	0.0	0.9	0.0	0.3	0.0	1.1	0.0	0.7				
<b>Intersection Summary</b>												
HCM 6th Ctrl Delay			20.5									
HCM 6th LOS			C									

Lanes, Volumes, Timings  
2: Michigan Ave. & Center St.

EAP (2022) Conditions  
AM PEAK HOUR

												
Lane Group	EBL	EBT	EBR	WBL	WBT	WBR	NBL	NBT	NBR	SBL	SBT	SBR
Lane Configurations		 			 			 			 	
Traffic Volume (vph)	42	113	7	12	176	17	7	28	6	8	21	25
Future Volume (vph)	42	113	7	12	176	17	7	28	6	8	21	25
Ideal Flow (vphpl)	1900	1900	1900	1900	1900	1900	1900	1900	1900	1900	1900	1900
Storage Length (ft)	0		50	0		50	0		50	115		0
Storage Lanes	0		1	0		1	0		1	1		1
Taper Length (ft)	90			90			90			90		
Link Speed (mph)		40			40			30			30	
Link Distance (ft)		841			2630			440			477	
Travel Time (s)		14.3			44.8			10.0			10.8	
Peak Hour Factor	0.83	0.83	0.83	0.83	0.83	0.83	0.83	0.83	0.83	0.83	0.83	0.83
Shared Lane Traffic (%)												
Sign Control		Stop			Stop			Stop			Stop	
<b>Intersection Summary</b>												
Area Type:	Other											
Control Type:	Unsignalized											

Intersection	
Intersection Delay, s/veh	9
Intersection LOS	A



















Movement	EBL	EBT	EBR	WBL	WBT	WBR	NBL	NBT	NBR	SBL	SBT	SBR
Lane Configurations		↕↕	↕		↕↕	↕		↕	↕		↕	↕
Traffic Vol, veh/h	42	113	7	12	176	17	7	28	6	8	21	25
Future Vol, veh/h	42	113	7	12	176	17	7	28	6	8	21	25
Peak Hour Factor	0.83	0.83	0.83	0.83	0.83	0.83	0.83	0.83	0.83	0.83	0.83	0.83
Heavy Vehicles, %	2	2	2	2	2	2	2	2	2	2	2	2
Mvmt Flow	51	136	8	14	212	20	8	34	7	10	25	30
Number of Lanes	0	2	1	0	2	1	0	1	1	0	1	1

Approach	EB	WB	NB	SB
Opposing Approach	WB	EB	SB	NB
Opposing Lanes	3	3	2	2
Conflicting Approach Left	SB	NB	EB	WB
Conflicting Lanes Left	2	2	3	3
Conflicting Approach Right	NB	SB	WB	EB
Conflicting Lanes Right	2	2	3	3
HCM Control Delay	9.1	9.1	8.9	8.6
HCM LOS	A	A	A	A

Lane	NBLn1	NBLn2	EBLn1	EBLn2	EBLn3	WBLn1	WBLn2	WBLn3	SBLn1	SBLn2
Vol Left, %	20%	0%	53%	0%	0%	17%	0%	0%	28%	0%
Vol Thru, %	80%	0%	47%	100%	0%	83%	100%	0%	72%	0%
Vol Right, %	0%	100%	0%	0%	100%	0%	0%	100%	0%	100%
Sign Control	Stop	Stop	Stop	Stop	Stop	Stop	Stop	Stop	Stop	Stop
Traffic Vol by Lane	35	6	80	75	7	71	117	17	29	25
LT Vol	7	0	42	0	0	12	0	0	8	0
Through Vol	28	0	38	75	0	59	117	0	21	0
RT Vol	0	6	0	0	7	0	0	17	0	25
Lane Flow Rate	42	7	96	91	8	85	141	20	35	30
Geometry Grp	8	8	8	8	8	8	8	8	8	8
Degree of Util (X)	0.069	0.01	0.15	0.135	0.011	0.127	0.208	0.026	0.057	0.043
Departure Headway (Hd)	5.911	5.111	5.634	5.369	4.667	5.372	5.287	4.584	5.92	5.083
Convergence, Y/N	Yes	Yes	Yes	Yes	Yes	Yes	Yes	Yes	Yes	Yes
Cap	602	694	633	664	762	665	677	777	601	699
Service Time	3.685	2.885	3.392	3.127	2.424	3.123	3.038	2.336	3.691	2.854
HCM Lane V/C Ratio	0.07	0.01	0.152	0.137	0.01	0.128	0.208	0.026	0.058	0.043
HCM Control Delay	9.1	7.9	9.4	9	7.5	8.9	9.4	7.5	9.1	8.1
HCM Lane LOS	A	A	A	A	A	A	A	A	A	A
HCM 95th-tile Q	0.2	0	0.5	0.5	0	0.4	0.8	0.1	0.2	0.1

Lanes, Volumes, Timings  
3: Mt. Vernon Ave. & Main St.

EAP (2022) Conditions  
AM PEAK HOUR

												
Lane Group	EBL	EBT	EBR	WBL	WBT	WBR	NBL	NBT	NBR	SBL	SBT	SBR
Lane Configurations												
Traffic Volume (vph)	40	17	10	9	11	37	23	265	2	11	222	49
Future Volume (vph)	40	17	10	9	11	37	23	265	2	11	222	49
Ideal Flow (vphpl)	1900	1900	1900	1900	1900	1900	1900	1900	1900	1900	1900	1900
Storage Length (ft)	0		50	0		0	0		50	0		50
Storage Lanes	0		1	0		0	0		1	0		1
Taper Length (ft)	90			90			90			90		
Link Speed (mph)		40			40			40			40	
Link Distance (ft)		1252			1253			777			936	
Travel Time (s)		21.3			21.4			13.2			16.0	
Peak Hour Factor	0.88	0.88	0.88	0.88	0.88	0.88	0.88	0.88	0.88	0.88	0.88	0.88
Shared Lane Traffic (%)												
Sign Control		Stop			Stop			Stop			Stop	
<b>Intersection Summary</b>												
Area Type:	Other											
Control Type:	Unsignalized											

Intersection	
Intersection Delay, s/veh	12.1
Intersection LOS	B

Movement	EBL	EBT	EBR	WBL	WBT	WBR	NBL	NBT	NBR	SBL	SBT	SBR
Lane Configurations		↖	↗		↔			↖	↗		↖↗	↗
Traffic Vol, veh/h	40	17	10	9	11	37	23	265	2	11	222	49
Future Vol, veh/h	40	17	10	9	11	37	23	265	2	11	222	49
Peak Hour Factor	0.88	0.88	0.88	0.88	0.88	0.88	0.88	0.88	0.88	0.88	0.88	0.88
Heavy Vehicles, %	2	2	2	2	2	2	2	2	2	2	2	2
Mvmt Flow	45	19	11	10	13	42	26	301	2	13	252	56
Number of Lanes	0	1	1	0	1	0	0	1	1	0	2	1

Approach	EB	WB	NB	SB
Opposing Approach	WB	EB	SB	NB
Opposing Lanes	1	2	3	2
Conflicting Approach Left	SB	NB	EB	WB
Conflicting Lanes Left	3	2	2	1
Conflicting Approach Right	NB	SB	WB	EB
Conflicting Lanes Right	2	3	1	2
HCM Control Delay	10.4	9.8	14.9	10.1
HCM LOS	B	A	B	B

Lane	NBLn1	NBLn2	EBLn1	EBLn2	WBLn1	SBLn1	SBLn2	SBLn3
Vol Left, %	8%	0%	70%	0%	16%	13%	0%	0%
Vol Thru, %	92%	0%	30%	0%	19%	87%	100%	0%
Vol Right, %	0%	100%	0%	100%	65%	0%	0%	100%
Sign Control	Stop	Stop	Stop	Stop	Stop	Stop	Stop	Stop
Traffic Vol by Lane	288	2	57	10	57	85	148	49
LT Vol	23	0	40	0	9	11	0	0
Through Vol	265	0	17	0	11	74	148	0
RT Vol	0	2	0	10	37	0	0	49
Lane Flow Rate	327	2	65	11	65	97	168	56
Geometry Grp	8	8	8	8	8	8	8	8
Degree of Util (X)	0.529	0.003	0.126	0.019	0.113	0.159	0.274	0.08
Departure Headway (Hd)	5.817	5.072	6.98	5.92	6.294	5.932	5.867	5.161
Convergence, Y/N	Yes	Yes	Yes	Yes	Yes	Yes	Yes	Yes
Cap	622	706	514	604	569	605	612	694
Service Time	3.547	2.801	4.723	3.663	4.038	3.664	3.599	2.893
HCM Lane V/C Ratio	0.526	0.003	0.126	0.018	0.114	0.16	0.275	0.081
HCM Control Delay	14.9	7.8	10.7	8.8	9.8	9.8	10.8	8.3
HCM Lane LOS	B	A	B	A	A	A	B	A
HCM 95th-tile Q	3.1	0	0.4	0.1	0.4	0.6	1.1	0.3

Lanes, Volumes, Timings  
4: Mt. Vernon Ave. & Spring St.

EAP (2022) Conditions  
AM PEAK HOUR

Lane Group	EBL	EBT	EBR	WBL	WBT	WBR	NBL	NBT	NBR	SBL	SBT	SBR
Lane Configurations												
Traffic Volume (vph)	12	7	9	23	23	95	7	149	9	28	183	21
Future Volume (vph)	12	7	9	23	23	95	7	149	9	28	183	21
Ideal Flow (vphpl)	1900	1900	1900	1900	1900	1900	1900	1900	1900	1900	1900	1900
Storage Length (ft)	140		0	165		0	200		0	205		205
Storage Lanes	1		0	1		0	1		0	1		1
Taper Length (ft)	90			60			90			90		
Right Turn on Red			Yes			Yes			Yes			Yes
Link Speed (mph)		30			30			40			40	
Link Distance (ft)		549			688			569			394	
Travel Time (s)		12.5			15.6			9.7			6.7	
Peak Hour Factor	0.79	0.79	0.79	0.79	0.79	0.79	0.79	0.79	0.79	0.79	0.79	0.79
Shared Lane Traffic (%)												
Turn Type	Prot	NA		Prot	NA		Prot	NA		Prot	NA	Perm
Protected Phases	7	4		3	8		5	2		1	6	
Permitted Phases												6
Detector Phase	7	4		3	8		5	2		1	6	6
Switch Phase												
Minimum Initial (s)	4.0	4.0		4.0	4.0		4.0	4.0		4.0	4.0	4.0
Minimum Split (s)	8.0	22.0		8.0	22.0		8.0	22.0		8.0	22.0	22.0
Total Split (s)	8.0	22.0		8.0	22.0		8.0	22.0		8.0	22.0	22.0
Total Split (%)	13.3%	36.7%		13.3%	36.7%		13.3%	36.7%		13.3%	36.7%	36.7%
Yellow Time (s)	3.5	3.5		3.5	3.5		3.5	3.5		3.5	3.5	3.5
All-Red Time (s)	0.5	0.5		0.5	0.5		0.5	0.5		0.5	0.5	0.5
Lost Time Adjust (s)	0.0	0.0		0.0	0.0		0.0	0.0		0.0	0.0	0.0
Total Lost Time (s)	4.0	4.0		4.0	4.0		4.0	4.0		4.0	4.0	4.0
Lead/Lag	Lead	Lag		Lead	Lag		Lead	Lag		Lead	Lag	Lag
Lead-Lag Optimize?	Yes	Yes		Yes	Yes		Yes	Yes		Yes	Yes	Yes
Recall Mode	None	None		None	None		None	C-Max		None	C-Max	C-Max

Intersection Summary





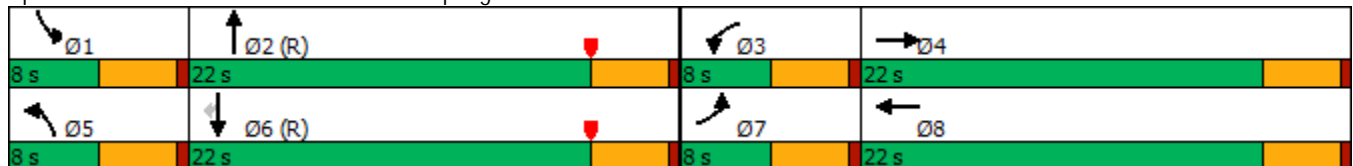

















Area Type: Other  
 Cycle Length: 60  
 Actuated Cycle Length: 60  
 Offset: 0 (0%), Referenced to phase 2:NBT and 6:SBT, Start of Yellow  
 Natural Cycle: 60  
 Control Type: Actuated-Coordinated

Splits and Phases: 4: Mt. Vernon Ave. & Spring St.



HCM 6th Signalized Intersection Summary  
4: Mt. Vernon Ave. & Spring St.

EAP (2022) Conditions  
AM PEAK HOUR

												
Movement	EBL	EBT	EBR	WBL	WBT	WBR	NBL	NBT	NBR	SBL	SBT	SBR
Lane Configurations												
Traffic Volume (veh/h)	12	7	9	23	23	95	7	149	9	28	183	21
Future Volume (veh/h)	12	7	9	23	23	95	7	149	9	28	183	21
Initial Q (Qb), veh	0	0	0	0	0	0	0	0	0	0	0	0
Ped-Bike Adj(A_pbT)	1.00		1.00	1.00		1.00	1.00		1.00	1.00		1.00
Parking Bus, Adj	1.00	1.00	1.00	1.00	1.00	1.00	1.00	1.00	1.00	1.00	1.00	1.00
Work Zone On Approach		No			No			No			No	
Adj Sat Flow, veh/h/ln	1870	1870	1870	1870	1870	1870	1870	1870	1870	1870	1870	1870
Adj Flow Rate, veh/h	15	9	11	29	29	120	9	189	11	35	232	27
Peak Hour Factor	0.79	0.79	0.79	0.79	0.79	0.79	0.79	0.79	0.79	0.79	0.79	0.79
Percent Heavy Veh, %	2	2	2	2	2	2	2	2	2	2	2	2
Cap, veh/h	26	88	107	46	40	165	17	1924	111	52	1092	925
Arrive On Green	0.01	0.11	0.11	0.03	0.13	0.13	0.01	0.54	0.54	0.03	0.55	0.55
Sat Flow, veh/h	1781	766	936	1781	318	1316	1781	3414	197	1781	1870	1585
Grp Volume(v), veh/h	15	0	20	29	0	149	9	98	102	35	232	27
Grp Sat Flow(s),veh/h/ln	1781	0	1702	1781	0	1634	1781	1777	1835	1781	1870	1585
Q Serve(g_s), s	0.5	0.0	0.6	1.0	0.0	5.3	0.3	1.6	1.6	1.2	3.8	0.5
Cycle Q Clear(g_c), s	0.5	0.0	0.6	1.0	0.0	5.3	0.3	1.6	1.6	1.2	3.8	0.5
Prop In Lane	1.00		0.55	1.00		0.81	1.00		0.11	1.00		1.00
Lane Grp Cap(c), veh/h	26	0	195	46	0	205	17	1002	1034	52	1092	925
V/C Ratio(X)	0.57	0.00	0.10	0.64	0.00	0.73	0.54	0.10	0.10	0.67	0.21	0.03
Avail Cap(c_a), veh/h	119	0	511	119	0	490	119	1002	1034	119	1092	925
HCM Platoon Ratio	1.00	1.00	1.00	1.00	1.00	1.00	0.95	0.95	0.95	0.95	0.95	0.95
Upstream Filter(I)	1.00	0.00	1.00	1.00	0.00	1.00	1.00	1.00	1.00	1.00	1.00	1.00
Uniform Delay (d), s/veh	29.4	0.0	23.8	29.0	0.0	25.2	29.6	6.5	6.5	28.9	6.4	5.7
Incr Delay (d2), s/veh	18.0	0.0	0.2	13.8	0.0	4.9	25.0	0.2	0.2	13.6	0.4	0.1
Initial Q Delay(d3),s/veh	0.0	0.0	0.0	0.0	0.0	0.0	0.0	0.0	0.0	0.0	0.0	0.0
%ile BackOfQ(50%),veh/ln	0.3	0.0	0.3	0.6	0.0	2.2	0.2	0.5	0.5	0.7	1.2	0.1
Unsig. Movement Delay, s/veh												
LnGrp Delay(d),s/veh	47.4	0.0	24.0	42.8	0.0	30.1	54.6	6.7	6.7	42.5	6.8	5.7
LnGrp LOS	D	A	C	D	A	C	D	A	A	D	A	A
Approach Vol, veh/h		35			178			209			294	
Approach Delay, s/veh		34.0			32.2			8.7			11.0	
Approach LOS		C			C			A			B	
Timer - Assigned Phs	1	2	3	4	5	6	7	8				
Phs Duration (G+Y+Rc), s	5.8	37.8	5.5	10.9	4.6	39.0	4.9	11.5				
Change Period (Y+Rc), s	4.0	4.0	4.0	4.0	4.0	4.0	4.0	4.0				
Max Green Setting (Gmax), s	4.0	18.0	4.0	18.0	4.0	18.0	4.0	18.0				
Max Q Clear Time (g_c+I1), s	3.2	3.6	3.0	2.6	2.3	5.8	2.5	7.3				
Green Ext Time (p_c), s	0.0	0.8	0.0	0.0	0.0	1.0	0.0	0.5				
<b>Intersection Summary</b>												
HCM 6th Ctrl Delay				16.7								
HCM 6th LOS				B								

Lanes, Volumes, Timings  
 5: Mt. Vernon Ave. & Project Dwy. 1

EAP (2022) Conditions  
 AM PEAK HOUR



Lane Group	WBL	WBR	NBT	NBR	SBL	SBT
Lane Configurations						
Traffic Volume (vph)	44	39	256	52	33	186
Future Volume (vph)	44	39	256	52	33	186
Ideal Flow (vphpl)	1900	1900	1900	1900	1900	1900
Link Speed (mph)	30		40			40
Link Distance (ft)	206		287			777
Travel Time (s)	4.7		4.9			13.2
Peak Hour Factor	0.92	0.92	0.92	0.92	0.92	0.92
Shared Lane Traffic (%)						
Sign Control	Stop		Free			Free

Intersection Summary

Area Type: Other  
 Control Type: Unsignalized

Intersection						
Int Delay, s/veh	2.1					
Movement	WBL	WBR	NBT	NBR	SBL	SBT
Lane Configurations	TT		T			TT
Traffic Vol, veh/h	44	39	256	52	33	186
Future Vol, veh/h	44	39	256	52	33	186
Conflicting Peds, #/hr	0	0	0	0	0	0
Sign Control	Stop	Stop	Free	Free	Free	Free
RT Channelized	-	None	-	None	-	None
Storage Length	0	-	-	-	-	-
Veh in Median Storage, #	0	-	0	-	-	0
Grade, %	0	-	0	-	-	0
Peak Hour Factor	92	92	92	92	92	92
Heavy Vehicles, %	2	2	2	2	2	2
Mvmt Flow	48	42	278	57	36	202

Major/Minor	Minor1	Major1	Major2		
Conflicting Flow All	480	307	0	0	335
Stage 1	307	-	-	-	-
Stage 2	173	-	-	-	-
Critical Hdwy	6.63	6.23	-	-	4.13
Critical Hdwy Stg 1	5.43	-	-	-	-
Critical Hdwy Stg 2	5.83	-	-	-	-
Follow-up Hdwy	3.519	3.319	-	-	2.219
Pot Cap-1 Maneuver	530	732	-	-	1223
Stage 1	745	-	-	-	-
Stage 2	840	-	-	-	-
Platoon blocked, %			-	-	-
Mov Cap-1 Maneuver	513	732	-	-	1223
Mov Cap-2 Maneuver	513	-	-	-	-
Stage 1	720	-	-	-	-
Stage 2	840	-	-	-	-

Approach	WB	NB	SB
HCM Control Delay, s	12.1	0	1.2
HCM LOS	B		

Minor Lane/Major Mvmt	NBT	NBRWBLn1	SBL	SBT
Capacity (veh/h)	-	-	597	1223
HCM Lane V/C Ratio	-	-	0.151	0.029
HCM Control Delay (s)	-	-	12.1	8
HCM Lane LOS	-	-	B	A
HCM 95th %tile Q(veh)	-	-	0.5	0.1

Lanes, Volumes, Timings  
 6: Mt. Vernon Ave. & Project Dwy. 2

EAP (2022) Conditions  
 AM PEAK HOUR



Lane Group	WBL	WBR	NBT	NBR	SBL	SBT
Lane Configurations						
Traffic Volume (vph)	0	29	279	39	0	230
Future Volume (vph)	0	29	279	39	0	230
Ideal Flow (vphpl)	1900	1900	1900	1900	1900	1900
Link Speed (mph)	30		40			40
Link Distance (ft)	217		254			287
Travel Time (s)	4.9		4.3			4.9
Peak Hour Factor	0.92	0.92	0.92	0.92	0.92	0.92
Shared Lane Traffic (%)						
Sign Control	Stop		Free			Free

Intersection Summary

Area Type: Other  
 Control Type: Unsignalized

Intersection						
Int Delay, s/veh	0.5					
Movement	WBL	WBR	NBT	NBR	SBL	SBT
Lane Configurations		↗	↘			↕↕
Traffic Vol, veh/h	0	29	279	39	0	230
Future Vol, veh/h	0	29	279	39	0	230
Conflicting Peds, #/hr	0	0	0	0	0	0
Sign Control	Stop	Stop	Free	Free	Free	Free
RT Channelized	-	None	-	None	-	None
Storage Length	-	0	-	-	-	-
Veh in Median Storage, #	0	-	0	-	-	0
Grade, %	0	-	0	-	-	0
Peak Hour Factor	92	92	92	92	92	92
Heavy Vehicles, %	2	2	2	2	2	2
Mvmt Flow	0	32	303	42	0	250

Major/Minor	Minor1	Major1	Major2		
Conflicting Flow All	-	324	0	0	-
Stage 1	-	-	-	-	-
Stage 2	-	-	-	-	-
Critical Hdwy	-	6.23	-	-	-
Critical Hdwy Stg 1	-	-	-	-	-
Critical Hdwy Stg 2	-	-	-	-	-
Follow-up Hdwy	-	3.319	-	-	-
Pot Cap-1 Maneuver	0	716	-	-	0
Stage 1	0	-	-	-	0
Stage 2	0	-	-	-	0
Platoon blocked, %			-	-	-
Mov Cap-1 Maneuver	-	716	-	-	-
Mov Cap-2 Maneuver	-	-	-	-	-
Stage 1	-	-	-	-	-
Stage 2	-	-	-	-	-

Approach	WB	NB	SB
HCM Control Delay, s	10.3	0	0
HCM LOS	B		

Minor Lane/Major Mvmt	NBT	NBRWBLn1	SBT
Capacity (veh/h)	-	-	716
HCM Lane V/C Ratio	-	-	0.044
HCM Control Delay (s)	-	-	10.3
HCM Lane LOS	-	-	B
HCM 95th %tile Q(veh)	-	-	0.1

Lanes, Volumes, Timings  
 7: Center St. & Project Dwy. 3

EAP (2022) Conditions  
 AM PEAK HOUR

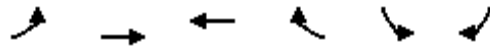

Lane Group	EBL	EBT	WBT	WBR	SBL	SBR
Lane Configurations		↑	↵			↗
Traffic Volume (vph)	0	88	202	7	0	16
Future Volume (vph)	0	88	202	7	0	16
Ideal Flow (vphpl)	1900	1900	1900	1900	1900	1900
Link Speed (mph)		40	40		30	
Link Distance (ft)		105	264		189	
Travel Time (s)		1.8	4.5		4.3	
Peak Hour Factor	0.92	0.92	0.92	0.92	0.92	0.92
Shared Lane Traffic (%)						
Sign Control		Free	Free		Stop	

Intersection Summary

Area Type: Other  
 Control Type: Unsignalized

Intersection						
Int Delay, s/veh	0.5					
Movement	EBL	EBT	WBT	WBR	SBL	SBR
Lane Configurations		↑	↑			↑
Traffic Vol, veh/h	0	88	202	7	0	16
Future Vol, veh/h	0	88	202	7	0	16
Conflicting Peds, #/hr	0	0	0	0	0	0
Sign Control	Free	Free	Free	Free	Stop	Stop
RT Channelized	-	None	-	None	-	None
Storage Length	-	-	-	-	-	0
Veh in Median Storage, #	-	0	0	-	0	-
Grade, %	-	0	0	-	0	-
Peak Hour Factor	92	92	92	92	92	92
Heavy Vehicles, %	2	2	2	2	2	2
Mvmt Flow	0	96	220	8	0	17

Major/Minor	Major1	Major2	Minor2
Conflicting Flow All	-	0	-
Stage 1	-	-	-
Stage 2	-	-	-
Critical Hdwy	-	-	-
Critical Hdwy Stg 1	-	-	-
Critical Hdwy Stg 2	-	-	-
Follow-up Hdwy	-	-	-
Pot Cap-1 Maneuver	0	-	-
Stage 1	0	-	-
Stage 2	0	-	-
Platoon blocked, %	-	-	-
Mov Cap-1 Maneuver	-	-	-
Mov Cap-2 Maneuver	-	-	-
Stage 1	-	-	-
Stage 2	-	-	-

Approach	EB	WB	SB
HCM Control Delay, s	0	0	9.5
HCM LOS			A

Minor Lane/Major Mvmt	EBT	WBT	WBR	SBLn1
Capacity (veh/h)	-	-	-	815
HCM Lane V/C Ratio	-	-	-	0.021
HCM Control Delay (s)	-	-	-	9.5
HCM Lane LOS	-	-	-	A
HCM 95th %tile Q(veh)	-	-	-	0.1

Lanes, Volumes, Timings  
 8: Center St. & Project Dwy. 4

EAP (2022) Conditions  
 AM PEAK HOUR

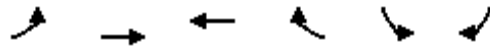

Lane Group	EBL	EBT	WBT	WBR	SBL	SBR
Lane Configurations		↑	↑		↑	
Traffic Volume (vph)	10	78	181	1	1	28
Future Volume (vph)	10	78	181	1	1	28
Ideal Flow (vphpl)	1900	1900	1900	1900	1900	1900
Link Speed (mph)		40	40		30	
Link Distance (ft)		264	515		187	
Travel Time (s)		4.5	8.8		4.3	
Peak Hour Factor	0.92	0.92	0.92	0.92	0.92	0.92
Shared Lane Traffic (%)						
Sign Control		Free	Free		Stop	

Intersection Summary

Area Type: Other  
 Control Type: Unsignalized

Intersection						
Int Delay, s/veh	1.2					
Movement	EBL	EBT	WBT	WBR	SBL	SBR
Lane Configurations		↑	↑		↑	
Traffic Vol, veh/h	10	78	181	1	1	28
Future Vol, veh/h	10	78	181	1	1	28
Conflicting Peds, #/hr	0	0	0	0	0	0
Sign Control	Free	Free	Free	Free	Stop	Stop
RT Channelized	-	None	-	None	-	None
Storage Length	-	-	-	-	0	-
Veh in Median Storage, #	-	0	0	-	0	-
Grade, %	-	0	0	-	0	-
Peak Hour Factor	92	92	92	92	92	92
Heavy Vehicles, %	2	2	2	2	2	2
Mvmt Flow	11	85	197	1	1	30

Major/Minor	Major1	Major2	Minor2		
Conflicting Flow All	198	0	-	0	305 198
Stage 1	-	-	-	-	198 -
Stage 2	-	-	-	-	107 -
Critical Hdwy	4.12	-	-	-	6.42 6.22
Critical Hdwy Stg 1	-	-	-	-	5.42 -
Critical Hdwy Stg 2	-	-	-	-	5.42 -
Follow-up Hdwy	2.218	-	-	-	3.518 3.318
Pot Cap-1 Maneuver	1375	-	-	-	687 843
Stage 1	-	-	-	-	835 -
Stage 2	-	-	-	-	917 -
Platoon blocked, %		-	-	-	
Mov Cap-1 Maneuver	1375	-	-	-	682 843
Mov Cap-2 Maneuver	-	-	-	-	682 -
Stage 1	-	-	-	-	828 -
Stage 2	-	-	-	-	917 -

Approach	EB	WB	SB
HCM Control Delay, s	0.9	0	9.5
HCM LOS			A

Minor Lane/Major Mvmt	EBL	EBT	WBT	WBR	SBLn1
Capacity (veh/h)	1375	-	-	-	836
HCM Lane V/C Ratio	0.008	-	-	-	0.038
HCM Control Delay (s)	7.6	-	-	-	9.5
HCM Lane LOS	A	-	-	-	A
HCM 95th %tile Q(veh)	0	-	-	-	0.1

Lanes, Volumes, Timings  
1: Mt. Vernon Ave. & Center St.

EAP (2022) Conditions  
PM PEAK HOUR

Lane Group	EBL	EBT	EBR	WBL	WBT	WBR	NBL	NBT	NBR	SBL	SBT	SBR
Lane Configurations												
Traffic Volume (vph)	102	65	19	26	57	40	17	270	17	56	226	91
Future Volume (vph)	102	65	19	26	57	40	17	270	17	56	226	91
Ideal Flow (vphpl)	1900	1900	1900	1900	1900	1900	1900	1900	1900	1900	1900	1900
Storage Length (ft)	185		0	150		150	210		210	150		0
Storage Lanes	1		0	1		0	1		1	1		0
Taper Length (ft)	90			60			60			90		
Right Turn on Red			Yes			Yes			Yes			Yes
Link Speed (mph)		40			40			40			40	
Link Distance (ft)		2630			193			444			254	
Travel Time (s)		44.8			3.3			7.6			4.3	
Peak Hour Factor	0.90	0.90	0.90	0.90	0.90	0.90	0.90	0.90	0.90	0.90	0.90	0.90
Shared Lane Traffic (%)												
Turn Type	Prot	NA		Prot	NA		Prot	NA	Perm	Prot	NA	
Protected Phases	7	4		3	8		5	2		1	6	
Permitted Phases									2			
Detector Phase	7	4		3	8		5	2	2	1	6	
Switch Phase												
Minimum Initial (s)	4.0	4.0		4.0	4.0		4.0	4.0	4.0	4.0	4.0	
Minimum Split (s)	8.0	22.0		8.0	22.0		8.0	22.0	22.0	8.0	22.0	
Total Split (s)	8.0	22.0		8.0	22.0		8.0	22.0	22.0	8.0	22.0	
Total Split (%)	13.3%	36.7%		13.3%	36.7%		13.3%	36.7%	36.7%	13.3%	36.7%	
Yellow Time (s)	3.5	3.5		3.5	3.5		3.5	3.5	3.5	3.5	3.5	
All-Red Time (s)	0.5	0.5		0.5	0.5		0.5	0.5	0.5	0.5	0.5	
Lost Time Adjust (s)	0.0	0.0		0.0	0.0		0.0	0.0	0.0	0.0	0.0	
Total Lost Time (s)	4.0	4.0		4.0	4.0		4.0	4.0	4.0	4.0	4.0	
Lead/Lag	Lead	Lag		Lead	Lag		Lead	Lag	Lag	Lead	Lag	
Lead-Lag Optimize?	Yes	Yes		Yes	Yes		Yes	Yes	Yes	Yes	Yes	
Recall Mode	None	None		None	None		None	C-Max	C-Max	None	C-Max	

Intersection Summary





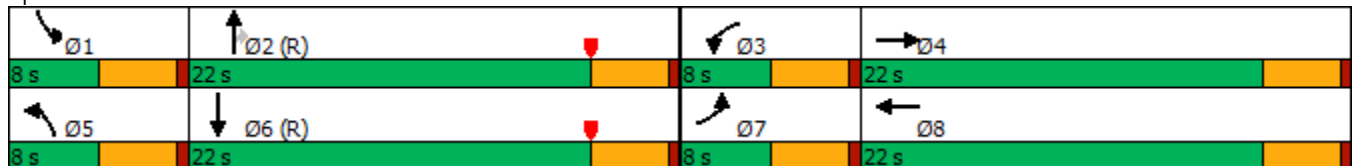

















Area Type: Other  
 Cycle Length: 60  
 Actuated Cycle Length: 60  
 Offset: 0 (0%), Referenced to phase 2:NBT and 6:SBT, Start of Yellow  
 Natural Cycle: 60  
 Control Type: Actuated-Coordinated

Splits and Phases: 1: Mt. Vernon Ave. & Center St.



























HCM 6th Signalized Intersection Summary  
 1: Mt. Vernon Ave. & Center St.

EAP (2022) Conditions  
 PM PEAK HOUR

												
Movement	EBL	EBT	EBR	WBL	WBT	WBR	NBL	NBT	NBR	SBL	SBT	SBR
Lane Configurations												
Traffic Volume (veh/h)	102	65	19	26	57	40	17	270	17	56	226	91
Future Volume (veh/h)	102	65	19	26	57	40	17	270	17	56	226	91
Initial Q (Qb), veh	0	0	0	0	0	0	0	0	0	0	0	0
Ped-Bike Adj(A_pbT)	1.00		1.00	1.00		1.00	1.00		1.00	1.00		1.00
Parking Bus, Adj	1.00	1.00	1.00	1.00	1.00	1.00	1.00	1.00	1.00	1.00	1.00	1.00
Work Zone On Approach		No			No			No			No	
Adj Sat Flow, veh/h/ln	1870	1870	1870	1870	1870	1870	1870	1870	1870	1870	1870	1870
Adj Flow Rate, veh/h	113	72	21	29	63	44	19	300	19	62	251	101
Peak Hour Factor	0.90	0.90	0.90	0.90	0.90	0.90	0.90	0.90	0.90	0.90	0.90	0.90
Percent Heavy Veh, %	2	2	2	2	2	2	2	2	2	2	2	2
Cap, veh/h	119	304	85	46	145	92	32	1035	877	78	1444	565
Arrive On Green	0.07	0.11	0.11	0.03	0.07	0.07	0.02	0.55	0.55	0.04	0.58	0.58
Sat Flow, veh/h	1781	2741	768	1781	2081	1328	1781	1870	1585	1781	2495	977
Grp Volume(v), veh/h	113	46	47	29	53	54	19	300	19	62	177	175
Grp Sat Flow(s),veh/h/ln	1781	1777	1732	1781	1777	1631	1781	1870	1585	1781	1777	1695
Q Serve(g_s), s	3.8	1.4	1.5	1.0	1.7	1.9	0.6	5.1	0.3	2.1	2.8	2.9
Cycle Q Clear(g_c), s	3.8	1.4	1.5	1.0	1.7	1.9	0.6	5.1	0.3	2.1	2.8	2.9
Prop In Lane	1.00		0.44	1.00		0.81	1.00		1.00	1.00		0.58
Lane Grp Cap(c), veh/h	119	197	192	46	124	114	32	1035	877	78	1029	981
V/C Ratio(X)	0.95	0.23	0.25	0.64	0.43	0.48	0.59	0.29	0.02	0.80	0.17	0.18
Avail Cap(c_a), veh/h	119	533	520	119	533	489	119	1035	877	119	1029	981
HCM Platoon Ratio	1.00	1.00	1.00	1.00	1.00	1.00	1.00	1.00	1.00	1.00	1.00	1.00
Upstream Filter(I)	1.00	1.00	1.00	1.00	1.00	1.00	1.00	1.00	1.00	1.00	1.00	1.00
Uniform Delay (d), s/veh	27.9	24.3	24.4	29.0	26.8	26.9	29.2	7.1	6.1	28.4	5.9	5.9
Incr Delay (d2), s/veh	67.3	0.6	0.7	13.8	2.3	3.1	15.9	0.7	0.0	18.8	0.4	0.4
Initial Q Delay(d3),s/veh	0.0	0.0	0.0	0.0	0.0	0.0	0.0	0.0	0.0	0.0	0.0	0.0
%ile BackOfQ(50%),veh/ln	3.7	0.6	0.6	0.6	0.7	0.8	0.4	1.7	0.1	1.2	0.8	0.8
Unsig. Movement Delay, s/veh												
LnGrp Delay(d),s/veh	95.2	24.9	25.1	42.8	29.1	29.9	45.2	7.8	6.1	47.3	6.3	6.3
LnGrp LOS	F	C	C	D	C	C	D	A	A	D	A	A
Approach Vol, veh/h		206			136			338			414	
Approach Delay, s/veh		63.5			32.3			9.8			12.4	
Approach LOS		E			C			A			B	
Timer - Assigned Phs	1	2	3	4	5	6	7	8				
Phs Duration (G+Y+Rc), s	6.6	37.2	5.5	10.6	5.1	38.7	8.0	8.2				
Change Period (Y+Rc), s	4.0	4.0	4.0	4.0	4.0	4.0	4.0	4.0				
Max Green Setting (Gmax), s	4.0	18.0	4.0	18.0	4.0	18.0	4.0	18.0				
Max Q Clear Time (g_c+I1), s	4.1	7.1	3.0	3.5	2.6	4.9	5.8	3.9				
Green Ext Time (p_c), s	0.0	1.2	0.0	0.3	0.0	1.5	0.0	0.4				
<b>Intersection Summary</b>												
HCM 6th Ctrl Delay				23.7								
HCM 6th LOS				C								

Lanes, Volumes, Timings  
2: Michigan Ave. & Center St.

EAP (2022) Conditions  
PM PEAK HOUR

												
Lane Group	EBL	EBT	EBR	WBL	WBT	WBR	NBL	NBT	NBR	SBL	SBT	SBR
Lane Configurations		 			 			 			 	
Traffic Volume (vph)	88	195	4	22	153	29	4	24	18	20	42	58
Future Volume (vph)	88	195	4	22	153	29	4	24	18	20	42	58
Ideal Flow (vphpl)	1900	1900	1900	1900	1900	1900	1900	1900	1900	1900	1900	1900
Storage Length (ft)	0		50	0		50	0		50	115		0
Storage Lanes	0		1	0		1	0		1	1		1
Taper Length (ft)	90			90			90			90		
Link Speed (mph)		40			40			30			30	
Link Distance (ft)		841			2630			440			477	
Travel Time (s)		14.3			44.8			10.0			10.8	
Peak Hour Factor	0.94	0.94	0.94	0.94	0.94	0.94	0.94	0.94	0.94	0.94	0.94	0.94
Shared Lane Traffic (%)												
Sign Control		Stop			Stop			Stop			Stop	
<b>Intersection Summary</b>												
Area Type:	Other											
Control Type:	Unsignalized											

Intersection	
Intersection Delay, s/veh	9.8
Intersection LOS	A



















Movement	EBL	EBT	EBR	WBL	WBT	WBR	NBL	NBT	NBR	SBL	SBT	SBR
Lane Configurations		↔↔	↔		↔↔	↔		↔	↔		↔	↔
Traffic Vol, veh/h	88	195	4	22	153	29	4	24	18	20	42	58
Future Vol, veh/h	88	195	4	22	153	29	4	24	18	20	42	58
Peak Hour Factor	0.94	0.94	0.94	0.94	0.94	0.94	0.94	0.94	0.94	0.94	0.94	0.94
Heavy Vehicles, %	2	2	2	2	2	2	2	2	2	2	2	2
Mvmt Flow	94	207	4	23	163	31	4	26	19	21	45	62
Number of Lanes	0	2	1	0	2	1	0	1	1	0	1	1

Approach	EB	WB	NB	SB
Opposing Approach	WB	EB	SB	NB
Opposing Lanes	3	3	2	2
Conflicting Approach Left	SB	NB	EB	WB
Conflicting Lanes Left	2	2	3	3
Conflicting Approach Right	NB	SB	WB	EB
Conflicting Lanes Right	2	2	3	3
HCM Control Delay	10.3	9.5	9.1	9.3
HCM LOS	B	A	A	A

Lane	NBLn1	NBLn2	EBLn1	EBLn2	EBLn3	WBLn1	WBLn2	WBLn3	SBLn1	SBLn2
Vol Left, %	14%	0%	58%	0%	0%	30%	0%	0%	32%	0%
Vol Thru, %	86%	0%	42%	100%	0%	70%	100%	0%	68%	0%
Vol Right, %	0%	100%	0%	0%	100%	0%	0%	100%	0%	100%
Sign Control	Stop	Stop	Stop	Stop	Stop	Stop	Stop	Stop	Stop	Stop
Traffic Vol by Lane	28	18	153	130	4	73	102	29	62	58
LT Vol	4	0	88	0	0	22	0	0	20	0
Through Vol	24	0	65	130	0	51	102	0	42	0
RT Vol	0	18	0	0	4	0	0	29	0	58
Lane Flow Rate	30	19	163	138	4	78	109	31	66	62
Geometry Grp	8	8	8	8	8	8	8	8	8	8
Degree of Util (X)	0.053	0.03	0.267	0.216	0.006	0.129	0.175	0.044	0.115	0.093
Departure Headway (Hd)	6.381	5.608	5.914	5.625	4.92	5.968	5.817	5.112	6.284	5.423
Convergence, Y/N	Yes	Yes	Yes	Yes	Yes	Yes	Yes	Yes	Yes	Yes
Cap	562	639	610	642	730	603	620	703	571	661
Service Time	4.111	3.338	3.623	3.334	2.63	3.679	3.527	2.823	4.011	3.149
HCM Lane V/C Ratio	0.053	0.03	0.267	0.215	0.005	0.129	0.176	0.044	0.116	0.094
HCM Control Delay	9.5	8.5	10.8	9.9	7.7	9.6	9.8	8.1	9.8	8.7
HCM Lane LOS	A	A	B	A	A	A	A	A	A	A
HCM 95th-tile Q	0.2	0.1	1.1	0.8	0	0.4	0.6	0.1	0.4	0.3

Lanes, Volumes, Timings  
3: Mt. Vernon Ave. & Main St.

EAP (2022) Conditions  
PM PEAK HOUR

												
Lane Group	EBL	EBT	EBR	WBL	WBT	WBR	NBL	NBT	NBR	SBL	SBT	SBR
Lane Configurations												
Traffic Volume (vph)	54	35	12	4	15	26	9	368	19	42	351	47
Future Volume (vph)	54	35	12	4	15	26	9	368	19	42	351	47
Ideal Flow (vphpl)	1900	1900	1900	1900	1900	1900	1900	1900	1900	1900	1900	1900
Storage Length (ft)	0		50	0		0	0		50	0		50
Storage Lanes	0		1	0		0	0		1	0		1
Taper Length (ft)	90			90			90			90		
Link Speed (mph)		40			40			40			40	
Link Distance (ft)		1252			1253			777			936	
Travel Time (s)		21.3			21.4			13.2			16.0	
Peak Hour Factor	0.84	0.84	0.84	0.84	0.84	0.84	0.84	0.84	0.84	0.84	0.84	0.84
Shared Lane Traffic (%)												
Sign Control		Stop			Stop			Stop			Stop	
<b>Intersection Summary</b>												
Area Type:	Other											
Control Type:	Unsignalized											

Intersection	
Intersection Delay, s/veh	20.7
Intersection LOS	C

Movement	EBL	EBT	EBR	WBL	WBT	WBR	NBL	NBT	NBR	SBL	SBT	SBR
Lane Configurations		↕	↕		↕			↕	↕		↕↕	↕
Traffic Vol, veh/h	54	35	12	4	15	26	9	368	19	42	351	47
Future Vol, veh/h	54	35	12	4	15	26	9	368	19	42	351	47
Peak Hour Factor	0.84	0.84	0.84	0.84	0.84	0.84	0.84	0.84	0.84	0.84	0.84	0.84
Heavy Vehicles, %	2	2	2	2	2	2	2	2	2	2	2	2
Mvmt Flow	64	42	14	5	18	31	11	438	23	50	418	56
Number of Lanes	0	1	1	0	1	0	0	1	1	0	2	1

Approach	EB	WB	NB	SB
Opposing Approach	WB	EB	SB	NB
Opposing Lanes	1	2	3	2
Conflicting Approach Left	SB	NB	EB	WB
Conflicting Lanes Left	3	2	2	1
Conflicting Approach Right	NB	SB	WB	EB
Conflicting Lanes Right	2	3	1	2
HCM Control Delay	13	11.4	30.9	14.2
HCM LOS	B	B	D	B

Lane	NBLn1	NBLn2	EBLn1	EBLn2	WBLn1	SBLn1	SBLn2	SBLn3
Vol Left, %	2%	0%	61%	0%	9%	26%	0%	0%
Vol Thru, %	98%	0%	39%	0%	33%	74%	100%	0%
Vol Right, %	0%	100%	0%	100%	58%	0%	0%	100%
Sign Control	Stop	Stop	Stop	Stop	Stop	Stop	Stop	Stop
Traffic Vol by Lane	377	19	89	12	45	159	234	47
LT Vol	9	0	54	0	4	42	0	0
Through Vol	368	0	35	0	15	117	234	0
RT Vol	0	19	0	12	26	0	0	47
Lane Flow Rate	449	23	106	14	54	189	279	56
Geometry Grp	8	8	8	8	8	8	8	8
Degree of Util (X)	0.813	0.036	0.239	0.028	0.115	0.351	0.506	0.091
Departure Headway (Hd)	6.523	5.803	8.133	7.111	7.72	6.668	6.535	5.825
Convergence, Y/N	Yes	Yes	Yes	Yes	Yes	Yes	Yes	Yes
Cap	552	611	444	506	467	536	546	609
Service Time	4.318	3.597	5.837	4.815	5.426	4.466	4.332	3.621
HCM Lane V/C Ratio	0.813	0.038	0.239	0.028	0.116	0.353	0.511	0.092
HCM Control Delay	32	8.8	13.4	10	11.4	13.1	15.9	9.2
HCM Lane LOS	D	A	B	A	B	B	C	A
HCM 95th-tile Q	8	0.1	0.9	0.1	0.4	1.6	2.8	0.3

Lanes, Volumes, Timings  
4: Mt. Vernon Ave. & Spring St.

EAP (2022) Conditions  
PM PEAK HOUR

Lane Group	EBL	EBT	EBR	WBL	WBT	WBR	NBL	NBT	NBR	SBL	SBT	SBR
Lane Configurations												
Traffic Volume (vph)	14	21	5	26	15	60	11	241	33	88	178	8
Future Volume (vph)	14	21	5	26	15	60	11	241	33	88	178	8
Ideal Flow (vphpl)	1900	1900	1900	1900	1900	1900	1900	1900	1900	1900	1900	1900
Storage Length (ft)	140		0	165		0	200		0	205		205
Storage Lanes	1		0	1		0	1		0	1		1
Taper Length (ft)	90			60			90			90		
Right Turn on Red			Yes			Yes			Yes			Yes
Link Speed (mph)		30			30			40			40	
Link Distance (ft)		549			688			569			394	
Travel Time (s)		12.5			15.6			9.7			6.7	
Peak Hour Factor	0.91	0.91	0.91	0.91	0.91	0.91	0.91	0.91	0.91	0.91	0.91	0.91
Shared Lane Traffic (%)												
Turn Type	Prot	NA		Prot	NA		Prot	NA		Prot	NA	Perm
Protected Phases	7	4		3	8		5	2		1	6	
Permitted Phases												6
Detector Phase	7	4		3	8		5	2		1	6	6
Switch Phase												
Minimum Initial (s)	4.0	4.0		4.0	4.0		4.0	4.0		4.0	4.0	4.0
Minimum Split (s)	8.0	22.0		8.0	22.0		8.0	22.0		8.0	22.0	22.0
Total Split (s)	8.0	22.0		8.0	22.0		8.0	22.0		8.0	22.0	22.0
Total Split (%)	13.3%	36.7%		13.3%	36.7%		13.3%	36.7%		13.3%	36.7%	36.7%
Yellow Time (s)	3.5	3.5		3.5	3.5		3.5	3.5		3.5	3.5	3.5
All-Red Time (s)	0.5	0.5		0.5	0.5		0.5	0.5		0.5	0.5	0.5
Lost Time Adjust (s)	0.0	0.0		0.0	0.0		0.0	0.0		0.0	0.0	0.0
Total Lost Time (s)	4.0	4.0		4.0	4.0		4.0	4.0		4.0	4.0	4.0
Lead/Lag	Lead	Lag		Lead	Lag		Lead	Lag		Lead	Lag	Lag
Lead-Lag Optimize?	Yes	Yes		Yes	Yes		Yes	Yes		Yes	Yes	Yes
Recall Mode	None	None		None	None		None	C-Max		None	C-Max	C-Max

Intersection Summary

Area Type: Other  
 Cycle Length: 60  
 Actuated Cycle Length: 60  
 Offset: 0 (0%), Referenced to phase 2:NBT and 6:SBT, Start of Yellow  
 Natural Cycle: 60  
 Control Type: Actuated-Coordinated

Splits and Phases: 4: Mt. Vernon Ave. & Spring St.

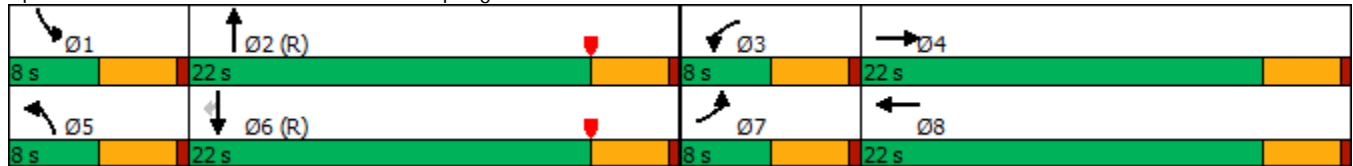

HCM 6th Signalized Intersection Summary  
4: Mt. Vernon Ave. & Spring St.

EAP (2022) Conditions  
PM PEAK HOUR

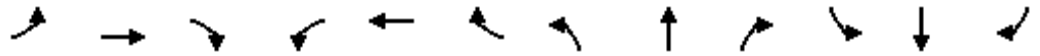

Movement	EBL	EBT	EBR	WBL	WBT	WBR	NBL	NBT	NBR	SBL	SBT	SBR
Lane Configurations												
Traffic Volume (veh/h)	14	21	5	26	15	60	11	241	33	88	178	8
Future Volume (veh/h)	14	21	5	26	15	60	11	241	33	88	178	8
Initial Q (Qb), veh	0	0	0	0	0	0	0	0	0	0	0	0
Ped-Bike Adj(A_pbT)	1.00		1.00	1.00		1.00	1.00		1.00	1.00		1.00
Parking Bus, Adj	1.00	1.00	1.00	1.00	1.00	1.00	1.00	1.00	1.00	1.00	1.00	1.00
Work Zone On Approach		No			No			No			No	
Adj Sat Flow, veh/h/ln	1870	1870	1870	1870	1870	1870	1870	1870	1870	1870	1870	1870
Adj Flow Rate, veh/h	15	23	5	29	16	66	12	265	36	97	196	9
Peak Hour Factor	0.91	0.91	0.91	0.91	0.91	0.91	0.91	0.91	0.91	0.91	0.91	0.91
Percent Heavy Veh, %	2	2	2	2	2	2	2	2	2	2	2	2
Cap, veh/h	26	100	22	46	25	103	22	1807	243	119	1175	996
Arrive On Green	0.01	0.07	0.07	0.03	0.08	0.08	0.01	0.57	0.57	0.07	0.63	0.63
Sat Flow, veh/h	1781	1489	324	1781	319	1315	1781	3148	423	1781	1870	1585
Grp Volume(v), veh/h	15	0	28	29	0	82	12	148	153	97	196	9
Grp Sat Flow(s),veh/h/ln	1781	0	1812	1781	0	1634	1781	1777	1794	1781	1870	1585
Q Serve(g_s), s	0.5	0.0	0.9	1.0	0.0	2.9	0.4	2.3	2.4	3.2	2.6	0.1
Cycle Q Clear(g_c), s	0.5	0.0	0.9	1.0	0.0	2.9	0.4	2.3	2.4	3.2	2.6	0.1
Prop In Lane	1.00		0.18	1.00		0.80	1.00		0.24	1.00		1.00
Lane Grp Cap(c), veh/h	26	0	122	46	0	128	22	1020	1030	119	1175	996
V/C Ratio(X)	0.57	0.00	0.23	0.64	0.00	0.64	0.56	0.15	0.15	0.82	0.17	0.01
Avail Cap(c_a), veh/h	119	0	544	119	0	490	119	1020	1030	119	1175	996
HCM Platoon Ratio	1.00	1.00	1.00	1.00	1.00	1.00	1.00	1.00	1.00	1.00	1.00	1.00
Upstream Filter(I)	1.00	0.00	1.00	1.00	0.00	1.00	1.00	1.00	1.00	1.00	1.00	1.00
Uniform Delay (d), s/veh	29.4	0.0	26.5	29.0	0.0	26.8	29.5	5.9	6.0	27.6	4.6	4.2
Incr Delay (d2), s/veh	18.0	0.0	0.9	13.8	0.0	5.3	20.6	0.3	0.3	34.1	0.3	0.0
Initial Q Delay(d3),s/veh	0.0	0.0	0.0	0.0	0.0	0.0	0.0	0.0	0.0	0.0	0.0	0.0
%ile BackOfQ(50%),veh/ln	0.3	0.0	0.4	0.6	0.0	1.3	0.3	0.7	0.7	2.4	0.7	0.0
Unsig. Movement Delay, s/veh												
LnGrp Delay(d),s/veh	47.4	0.0	27.5	42.8	0.0	32.2	50.1	6.2	6.3	61.7	4.9	4.2
LnGrp LOS	D	A	C	D	A	C	D	A	A	E	A	A
Approach Vol, veh/h		43			111			313			302	
Approach Delay, s/veh		34.4			34.9			7.9			23.2	
Approach LOS		C			C			A			C	
Timer - Assigned Phs	1	2	3	4	5	6	7	8				
Phs Duration (G+Y+Rc), s	8.0	38.4	5.5	8.0	4.7	41.7	4.9	8.7				
Change Period (Y+Rc), s	4.0	4.0	4.0	4.0	4.0	4.0	4.0	4.0				
Max Green Setting (Gmax), s	4.0	18.0	4.0	18.0	4.0	18.0	4.0	18.0				
Max Q Clear Time (g_c+I1), s	5.2	4.4	3.0	2.9	2.4	4.6	2.5	4.9				
Green Ext Time (p_c), s	0.0	1.3	0.0	0.1	0.0	0.8	0.0	0.3				

Intersection Summary

HCM 6th Ctrl Delay	19.3
HCM 6th LOS	B

Notes

User approved pedestrian interval to be less than phase max green.

Lanes, Volumes, Timings  
 5: Mt. Vernon Ave. & Project Dwy. 1

EAP (2022) Conditions  
 PM PEAK HOUR



Lane Group	WBL	WBR	NBT	NBR	SBL	SBT
Lane Configurations						
Traffic Volume (vph)	54	47	339	61	39	319
Future Volume (vph)	54	47	339	61	39	319
Ideal Flow (vphpl)	1900	1900	1900	1900	1900	1900
Link Speed (mph)	30		40			40
Link Distance (ft)	206		287			777
Travel Time (s)	4.7		4.9			13.2
Peak Hour Factor	0.92	0.92	0.92	0.92	0.92	0.92
Shared Lane Traffic (%)						
Sign Control	Stop		Free			Free

Intersection Summary

Area Type: Other  
 Control Type: Unsignalized

Intersection						
Int Delay, s/veh	2.1					
Movement	WBL	WBR	NBT	NBR	SBL	SBT
Lane Configurations	Y		T			↑↑
Traffic Vol, veh/h	54	47	339	61	39	319
Future Vol, veh/h	54	47	339	61	39	319
Conflicting Peds, #/hr	0	0	0	0	0	0
Sign Control	Stop	Stop	Free	Free	Free	Free
RT Channelized	-	None	-	None	-	None
Storage Length	0	-	-	-	-	-
Veh in Median Storage, #	0	-	0	-	-	0
Grade, %	0	-	0	-	-	0
Peak Hour Factor	92	92	92	92	92	92
Heavy Vehicles, %	2	2	2	2	2	2
Mvmt Flow	59	51	368	66	42	347

Major/Minor	Minor1	Major1	Major2		
Conflicting Flow All	659	401	0	0	434
Stage 1	401	-	-	-	-
Stage 2	258	-	-	-	-
Critical Hdwy	6.63	6.23	-	-	4.13
Critical Hdwy Stg 1	5.43	-	-	-	-
Critical Hdwy Stg 2	5.83	-	-	-	-
Follow-up Hdwy	3.519	3.319	-	-	2.219
Pot Cap-1 Maneuver	412	648	-	-	1124
Stage 1	675	-	-	-	-
Stage 2	762	-	-	-	-
Platoon blocked, %			-	-	-
Mov Cap-1 Maneuver	393	648	-	-	1124
Mov Cap-2 Maneuver	393	-	-	-	-
Stage 1	644	-	-	-	-
Stage 2	762	-	-	-	-

Approach	WB	NB	SB
HCM Control Delay, s	14.7	0	0.9
HCM LOS	B		

Minor Lane/Major Mvmt	NBT	NBRWBLn1	SBL	SBT
Capacity (veh/h)	-	-	481	1124
HCM Lane V/C Ratio	-	-	0.228	0.038
HCM Control Delay (s)	-	-	14.7	8.3
HCM Lane LOS	-	-	B	A
HCM 95th %tile Q(veh)	-	-	0.9	0.1

Lanes, Volumes, Timings  
6: Mt. Vernon Ave. & Project Dwy. 2

EAP (2022) Conditions  
PM PEAK HOUR



Lane Group	WBL	WBR	NBT	NBR	SBL	SBT
Lane Configurations						
Traffic Volume (vph)	0	35	365	46	0	373
Future Volume (vph)	0	35	365	46	0	373
Ideal Flow (vphpl)	1900	1900	1900	1900	1900	1900
Link Speed (mph)	30		40			40
Link Distance (ft)	217		254			287
Travel Time (s)	4.9		4.3			4.9
Peak Hour Factor	0.92	0.92	0.92	0.92	0.92	0.92
Shared Lane Traffic (%)						
Sign Control	Stop		Free			Free

Intersection Summary

Area Type: Other  
Control Type: Unsignalized

Intersection						
Int Delay, s/veh	0.5					
Movement	WBL	WBR	NBT	NBR	SBL	SBT
Lane Configurations		↗	↘			↕↕
Traffic Vol, veh/h	0	35	365	46	0	373
Future Vol, veh/h	0	35	365	46	0	373
Conflicting Peds, #/hr	0	0	0	0	0	0
Sign Control	Stop	Stop	Free	Free	Free	Free
RT Channelized	-	None	-	None	-	None
Storage Length	-	0	-	-	-	-
Veh in Median Storage, #	0	-	0	-	-	0
Grade, %	0	-	0	-	-	0
Peak Hour Factor	92	92	92	92	92	92
Heavy Vehicles, %	2	2	2	2	2	2
Mvmt Flow	0	38	397	50	0	405

Major/Minor	Minor1	Major1	Major2		
Conflicting Flow All	-	422	0	0	-
Stage 1	-	-	-	-	-
Stage 2	-	-	-	-	-
Critical Hdwy	-	6.23	-	-	-
Critical Hdwy Stg 1	-	-	-	-	-
Critical Hdwy Stg 2	-	-	-	-	-
Follow-up Hdwy	-	3.319	-	-	-
Pot Cap-1 Maneuver	0	631	-	-	0
Stage 1	0	-	-	-	0
Stage 2	0	-	-	-	0
Platoon blocked, %			-	-	-
Mov Cap-1 Maneuver	-	631	-	-	-
Mov Cap-2 Maneuver	-	-	-	-	-
Stage 1	-	-	-	-	-
Stage 2	-	-	-	-	-

Approach	WB	NB	SB
HCM Control Delay, s	11.1	0	0
HCM LOS	B		

Minor Lane/Major Mvmt	NBT	NBRWBLn1	SBT
Capacity (veh/h)	-	-	631
HCM Lane V/C Ratio	-	-	0.06
HCM Control Delay (s)	-	-	11.1
HCM Lane LOS	-	-	B
HCM 95th %tile Q(veh)	-	-	0.2

Lanes, Volumes, Timings  
7: Center St. & Project Dwy. 3

EAP (2022) Conditions  
PM PEAK HOUR

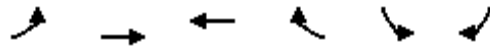

Lane Group	EBL	EBT	WBT	WBR	SBL	SBR
Lane Configurations		↑	↵			↶
Traffic Volume (vph)	0	138	102	8	0	20
Future Volume (vph)	0	138	102	8	0	20
Ideal Flow (vphpl)	1900	1900	1900	1900	1900	1900
Link Speed (mph)		40	40		30	
Link Distance (ft)		105	264		189	
Travel Time (s)		1.8	4.5		4.3	
Peak Hour Factor	0.92	0.92	0.92	0.92	0.92	0.92
Shared Lane Traffic (%)						
Sign Control		Free	Free		Stop	

Intersection Summary

Area Type: Other  
Control Type: Unsignalized

Intersection						
Int Delay, s/veh	0.7					
Movement	EBL	EBT	WBT	WBR	SBL	SBR
Lane Configurations		↑	↑			↑
Traffic Vol, veh/h	0	138	102	8	0	20
Future Vol, veh/h	0	138	102	8	0	20
Conflicting Peds, #/hr	0	0	0	0	0	0
Sign Control	Free	Free	Free	Free	Stop	Stop
RT Channelized	-	None	-	None	-	None
Storage Length	-	-	-	-	-	0
Veh in Median Storage, #	-	0	0	-	0	-
Grade, %	-	0	0	-	0	-
Peak Hour Factor	92	92	92	92	92	92
Heavy Vehicles, %	2	2	2	2	2	2
Mvmt Flow	0	150	111	9	0	22

Major/Minor	Major1	Major2	Minor2
Conflicting Flow All	-	0	-
Stage 1	-	-	-
Stage 2	-	-	-
Critical Hdwy	-	-	-
Critical Hdwy Stg 1	-	-	-
Critical Hdwy Stg 2	-	-	-
Follow-up Hdwy	-	-	-
Pot Cap-1 Maneuver	0	-	-
Stage 1	0	-	-
Stage 2	0	-	-
Platoon blocked, %	-	-	-
Mov Cap-1 Maneuver	-	-	-
Mov Cap-2 Maneuver	-	-	-
Stage 1	-	-	-
Stage 2	-	-	-

Approach	EB	WB	SB
HCM Control Delay, s	0	0	8.9
HCM LOS			A

Minor Lane/Major Mvmt	EBT	WBT	WBR	SBLn1
Capacity (veh/h)	-	-	-	936
HCM Lane V/C Ratio	-	-	-	0.023
HCM Control Delay (s)	-	-	-	8.9
HCM Lane LOS	-	-	-	A
HCM 95th %tile Q(veh)	-	-	-	0.1

Lanes, Volumes, Timings  
 8: Center St. & Project Dwy. 4

EAP (2022) Conditions  
 PM PEAK HOUR

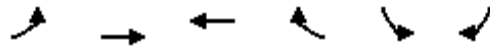

Lane Group	EBL	EBT	WBT	WBR	SBL	SBR
Lane Configurations		↑	↑		↑	
Traffic Volume (vph)	30	108	92	2	1	18
Future Volume (vph)	30	108	92	2	1	18
Ideal Flow (vphpl)	1900	1900	1900	1900	1900	1900
Link Speed (mph)		40	40		30	
Link Distance (ft)		264	515		187	
Travel Time (s)		4.5	8.8		4.3	
Peak Hour Factor	0.92	0.92	0.92	0.92	0.92	0.92
Shared Lane Traffic (%)						
Sign Control		Free	Free		Stop	

Intersection Summary

Area Type: Other  
 Control Type: Unsignalized

**Intersection**

Int Delay, s/veh 1.6

**Movement** EBL EBT WBT WBR SBL SBR

Lane Configurations		↑	↑		↑	
Traffic Vol, veh/h	30	108	92	2	1	18
Future Vol, veh/h	30	108	92	2	1	18
Conflicting Peds, #/hr	0	0	0	0	0	0
Sign Control	Free	Free	Free	Free	Stop	Stop
RT Channelized	-	None	-	None	-	None
Storage Length	-	-	-	-	0	-
Veh in Median Storage, #	-	0	0	-	0	-
Grade, %	-	0	0	-	0	-
Peak Hour Factor	92	92	92	92	92	92
Heavy Vehicles, %	2	2	2	2	2	2
Mvmt Flow	33	117	100	2	1	20

**Major/Minor** Major1 Major2 Minor2

Conflicting Flow All	102	0	-	0	284	101
Stage 1	-	-	-	-	101	-
Stage 2	-	-	-	-	183	-
Critical Hdwy	4.12	-	-	-	6.42	6.22
Critical Hdwy Stg 1	-	-	-	-	5.42	-
Critical Hdwy Stg 2	-	-	-	-	5.42	-
Follow-up Hdwy	2.218	-	-	-	3.518	3.318
Pot Cap-1 Maneuver	1490	-	-	-	706	954
Stage 1	-	-	-	-	923	-
Stage 2	-	-	-	-	848	-
Platoon blocked, %		-	-	-		
Mov Cap-1 Maneuver	1490	-	-	-	689	954
Mov Cap-2 Maneuver	-	-	-	-	689	-
Stage 1	-	-	-	-	901	-
Stage 2	-	-	-	-	848	-

**Approach** EB WB SB

HCM Control Delay, s 1.6 0 8.9  
HCM LOS A

**Minor Lane/Major Mvmt** EBL EBT WBT WBR SBLn1

Capacity (veh/h)	1490	-	-	-	935
HCM Lane V/C Ratio	0.022	-	-	-	0.022
HCM Control Delay (s)	7.5	-	-	-	8.9
HCM Lane LOS	A	-	-	-	A
HCM 95th %tile Q(veh)	0.1	-	-	-	0.1

**APPENDIX F**

EXISTING PLUS AMBIENT PLUS PROJECT PLUS CUMULATIVE  
(E+A+P+C 2022) CONDITIONS  
INTERSECTION ANALYSIS CALCULATION WORKSHEETS

THIS PAGE IS LEFT INTENTIONALLY BLANK

Lanes, Volumes, Timings  
1: Mt. Vernon Ave. & Center St.

EAPC (2022) Conditions  
AM PEAK HOUR

Lane Group	EBL	EBT	EBR	WBL	WBT	WBR	NBL	NBT	NBR	SBL	SBT	SBR
Lane Configurations												
Traffic Volume (vph)	75	51	34	50	109	69	21	196	30	16	169	68
Future Volume (vph)	75	51	34	50	109	69	21	196	30	16	169	68
Ideal Flow (vphpl)	1900	1900	1900	1900	1900	1900	1900	1900	1900	1900	1900	1900
Storage Length (ft)	185		0	150		150	210		210	150		0
Storage Lanes	1		0	1		0	1		1	1		0
Taper Length (ft)	90			60			60			90		
Right Turn on Red			Yes			Yes			Yes			Yes
Link Speed (mph)		40			40			40			40	
Link Distance (ft)		2630			193			444			254	
Travel Time (s)		44.8			3.3			7.6			4.3	
Peak Hour Factor	0.85	0.85	0.85	0.85	0.85	0.85	0.85	0.85	0.85	0.85	0.85	0.85
Shared Lane Traffic (%)												
Turn Type	Prot	NA		Prot	NA		Prot	NA	Perm	Prot	NA	
Protected Phases	7	4		3	8		5	2		1	6	
Permitted Phases									2			
Detector Phase	7	4		3	8		5	2	2	1	6	
Switch Phase												
Minimum Initial (s)	4.0	4.0		4.0	4.0		4.0	4.0	4.0	4.0	4.0	
Minimum Split (s)	8.0	22.0		8.0	22.0		8.0	22.0	22.0	8.0	22.0	
Total Split (s)	8.0	22.0		8.0	22.0		8.0	22.0	22.0	8.0	22.0	
Total Split (%)	13.3%	36.7%		13.3%	36.7%		13.3%	36.7%	36.7%	13.3%	36.7%	
Yellow Time (s)	3.5	3.5		3.5	3.5		3.5	3.5	3.5	3.5	3.5	
All-Red Time (s)	0.5	0.5		0.5	0.5		0.5	0.5	0.5	0.5	0.5	
Lost Time Adjust (s)	0.0	0.0		0.0	0.0		0.0	0.0	0.0	0.0	0.0	
Total Lost Time (s)	4.0	4.0		4.0	4.0		4.0	4.0	4.0	4.0	4.0	
Lead/Lag	Lead	Lag		Lead	Lag		Lead	Lag	Lag	Lead	Lag	
Lead-Lag Optimize?	Yes	Yes		Yes	Yes		Yes	Yes	Yes	Yes	Yes	
Recall Mode	None	None		None	None		None	C-Max	C-Max	None	C-Max	

Intersection Summary





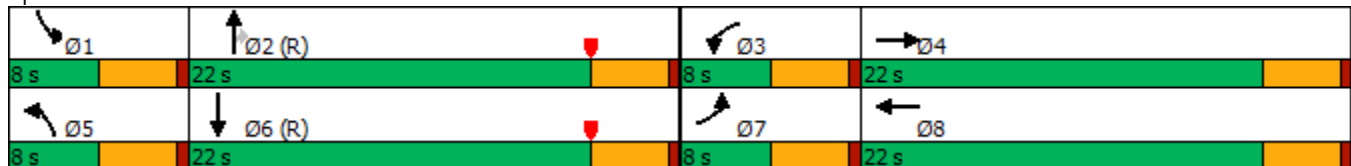

















Area Type: Other  
 Cycle Length: 60  
 Actuated Cycle Length: 60  
 Offset: 0 (0%), Referenced to phase 2:NBT and 6:SBT, Start of Yellow  
 Natural Cycle: 60  
 Control Type: Actuated-Coordinated

Splits and Phases: 1: Mt. Vernon Ave. & Center St.



























HCM 6th Signalized Intersection Summary  
1: Mt. Vernon Ave. & Center St.

EAPC (2022) Conditions  
AM PEAK HOUR

												
Movement	EBL	EBT	EBR	WBL	WBT	WBR	NBL	NBT	NBR	SBL	SBT	SBR
Lane Configurations												
Traffic Volume (veh/h)	75	51	34	50	109	69	21	196	30	16	169	68
Future Volume (veh/h)	75	51	34	50	109	69	21	196	30	16	169	68
Initial Q (Qb), veh	0	0	0	0	0	0	0	0	0	0	0	0
Ped-Bike Adj(A_pbT)	1.00		1.00	1.00		1.00	1.00		1.00	1.00		1.00
Parking Bus, Adj	1.00	1.00	1.00	1.00	1.00	1.00	1.00	1.00	1.00	1.00	1.00	1.00
Work Zone On Approach		No			No			No			No	
Adj Sat Flow, veh/h/ln	1870	1870	1870	1870	1870	1870	1870	1870	1870	1870	1870	1870
Adj Flow Rate, veh/h	88	60	40	59	128	81	25	231	35	19	199	80
Peak Hour Factor	0.85	0.85	0.85	0.85	0.85	0.85	0.85	0.85	0.85	0.85	0.85	0.85
Percent Heavy Veh, %	2	2	2	2	2	2	2	2	2	2	2	2
Cap, veh/h	112	272	166	74	230	136	40	1019	864	32	1351	525
Arrive On Green	0.06	0.13	0.13	0.04	0.11	0.11	0.02	0.55	0.55	0.02	0.54	0.54
Sat Flow, veh/h	1781	2120	1294	1781	2145	1273	1781	1870	1585	1781	2501	971
Grp Volume(v), veh/h	88	49	51	59	105	104	25	231	35	19	139	140
Grp Sat Flow(s),veh/h/ln	1781	1777	1637	1781	1777	1641	1781	1870	1585	1781	1777	1696
Q Serve(g_s), s	2.9	1.5	1.7	2.0	3.3	3.6	0.8	3.8	0.6	0.6	2.3	2.5
Cycle Q Clear(g_c), s	2.9	1.5	1.7	2.0	3.3	3.6	0.8	3.8	0.6	0.6	2.3	2.5
Prop In Lane	1.00		0.79	1.00		0.78	1.00		1.00	1.00		0.57
Lane Grp Cap(c), veh/h	112	228	210	74	190	176	40	1019	864	32	960	916
V/C Ratio(X)	0.78	0.22	0.24	0.79	0.55	0.59	0.62	0.23	0.04	0.59	0.15	0.15
Avail Cap(c_a), veh/h	119	533	491	119	533	492	119	1019	864	119	960	916
HCM Platoon Ratio	1.00	1.00	1.00	1.00	1.00	1.00	1.00	1.00	1.00	1.00	1.00	1.00
Upstream Filter(I)	1.00	1.00	1.00	1.00	1.00	1.00	1.00	1.00	1.00	1.00	1.00	1.00
Uniform Delay (d), s/veh	27.7	23.4	23.5	28.5	25.4	25.5	29.1	7.1	6.4	29.2	6.9	6.9
Incr Delay (d2), s/veh	26.9	0.5	0.6	17.0	2.5	3.2	14.3	0.5	0.1	15.9	0.3	0.4
Initial Q Delay(d3),s/veh	0.0	0.0	0.0	0.0	0.0	0.0	0.0	0.0	0.0	0.0	0.0	0.0
%ile BackOfQ(50%),veh/ln	2.0	0.6	0.6	1.1	1.4	1.4	0.5	1.3	0.2	0.4	0.7	0.7
Unsig. Movement Delay, s/veh												
LnGrp Delay(d),s/veh	54.6	23.9	24.1	45.5	27.9	28.7	43.4	7.6	6.4	45.2	7.2	7.3
LnGrp LOS	D	C	C	D	C	C	D	A	A	D	A	A
Approach Vol, veh/h		188			268			291			298	
Approach Delay, s/veh		38.3			32.1			10.5			9.6	
Approach LOS		D			C			B			A	
Timer - Assigned Phs	1	2	3	4	5	6	7	8				
Phs Duration (G+Y+Rc), s	5.1	36.7	6.5	11.7	5.4	36.4	7.8	10.4				
Change Period (Y+Rc), s	4.0	4.0	4.0	4.0	4.0	4.0	4.0	4.0				
Max Green Setting (Gmax), s	4.0	18.0	4.0	18.0	4.0	18.0	4.0	18.0				
Max Q Clear Time (g_c+I1), s	2.6	5.8	4.0	3.7	2.8	4.5	4.9	5.6				
Green Ext Time (p_c), s	0.0	1.0	0.0	0.3	0.0	1.2	0.0	0.8				
<b>Intersection Summary</b>												
HCM 6th Ctrl Delay				20.8								
HCM 6th LOS				C								

Lanes, Volumes, Timings  
2: Michigan Ave. & Center St.

EAPC (2022) Conditions  
AM PEAK HOUR

												
Lane Group	EBL	EBT	EBR	WBL	WBT	WBR	NBL	NBT	NBR	SBL	SBT	SBR
Lane Configurations		 			 			 			 	
Traffic Volume (vph)	51	132	7	12	199	17	7	30	6	8	24	36
Future Volume (vph)	51	132	7	12	199	17	7	30	6	8	24	36
Ideal Flow (vphpl)	1900	1900	1900	1900	1900	1900	1900	1900	1900	1900	1900	1900
Storage Length (ft)	0		50	0		50	0		50	115		0
Storage Lanes	0		1	0		1	0		1	1		1
Taper Length (ft)	90			90			90			90		
Link Speed (mph)		40			40			30				30
Link Distance (ft)		841			2630			440				477
Travel Time (s)		14.3			44.8			10.0				10.8
Peak Hour Factor	0.83	0.83	0.83	0.83	0.83	0.83	0.83	0.83	0.83	0.83	0.83	0.83
Shared Lane Traffic (%)												
Sign Control		Stop			Stop			Stop				Stop
<b>Intersection Summary</b>												
Area Type:	Other											
Control Type:	Unsignalized											

Intersection	
Intersection Delay, s/veh	9.4
Intersection LOS	A



















Movement	EBL	EBT	EBR	WBL	WBT	WBR	NBL	NBT	NBR	SBL	SBT	SBR
Lane Configurations		↔↔	↔		↔↔	↔		↔	↔		↔	↔
Traffic Vol, veh/h	51	132	7	12	199	17	7	30	6	8	24	36
Future Vol, veh/h	51	132	7	12	199	17	7	30	6	8	24	36
Peak Hour Factor	0.83	0.83	0.83	0.83	0.83	0.83	0.83	0.83	0.83	0.83	0.83	0.83
Heavy Vehicles, %	2	2	2	2	2	2	2	2	2	2	2	2
Mvmt Flow	61	159	8	14	240	20	8	36	7	10	29	43
Number of Lanes	0	2	1	0	2	1	0	1	1	0	1	1

Approach	EB	WB	NB	SB
Opposing Approach	WB	EB	SB	NB
Opposing Lanes	3	3	2	2
Conflicting Approach Left	SB	NB	EB	WB
Conflicting Lanes Left	2	2	3	3
Conflicting Approach Right	NB	SB	WB	EB
Conflicting Lanes Right	2	2	3	3
HCM Control Delay	9.5	9.5	9.2	8.8
HCM LOS	A	A	A	A

Lane	NBLn1	NBLn2	EBLn1	EBLn2	EBLn3	WBLn1	WBLn2	WBLn3	SBLn1	SBLn2
Vol Left, %	19%	0%	54%	0%	0%	15%	0%	0%	25%	0%
Vol Thru, %	81%	0%	46%	100%	0%	85%	100%	0%	75%	0%
Vol Right, %	0%	100%	0%	0%	100%	0%	0%	100%	0%	100%
Sign Control	Stop	Stop	Stop	Stop	Stop	Stop	Stop	Stop	Stop	Stop
Traffic Vol by Lane	37	6	95	88	7	78	133	17	32	36
LT Vol	7	0	51	0	0	12	0	0	8	0
Through Vol	30	0	44	88	0	66	133	0	24	0
RT Vol	0	6	0	0	7	0	0	17	0	36
Lane Flow Rate	45	7	114	106	8	94	160	20	39	43
Geometry Grp	8	8	8	8	8	8	8	8	8	8
Degree of Util (X)	0.076	0.011	0.183	0.162	0.011	0.144	0.241	0.027	0.065	0.063
Departure Headway (Hd)	6.108	5.314	5.766	5.496	4.793	5.501	5.424	4.721	6.082	5.257
Convergence, Y/N	Yes	Yes	Yes	Yes	Yes	Yes	Yes	Yes	Yes	Yes
Cap	581	666	618	648	740	647	657	751	584	674
Service Time	3.905	3.11	3.541	3.271	2.567	3.272	3.195	2.492	3.874	3.049
HCM Lane V/C Ratio	0.077	0.011	0.184	0.164	0.011	0.145	0.244	0.027	0.067	0.064
HCM Control Delay	9.4	8.2	9.8	9.3	7.6	9.2	9.9	7.6	9.3	8.4
HCM Lane LOS	A	A	A	A	A	A	A	A	A	A
HCM 95th-tile Q	0.2	0	0.7	0.6	0	0.5	0.9	0.1	0.2	0.2

Lanes, Volumes, Timings  
3: Mt. Vernon Ave. & Main St.

EAPC (2022) Conditions  
AM PEAK HOUR

												
Lane Group	EBL	EBT	EBR	WBL	WBT	WBR	NBL	NBT	NBR	SBL	SBT	SBR
Lane Configurations												
Traffic Volume (vph)	41	26	10	9	20	37	23	287	2	11	247	51
Future Volume (vph)	41	26	10	9	20	37	23	287	2	11	247	51
Ideal Flow (vphpl)	1900	1900	1900	1900	1900	1900	1900	1900	1900	1900	1900	1900
Storage Length (ft)	0		50	0		0	0		50	0		50
Storage Lanes	0		1	0		0	0		1	0		1
Taper Length (ft)	90			90			90			90		
Link Speed (mph)		40			40			40			40	
Link Distance (ft)		1252			1253			777			936	
Travel Time (s)		21.3			21.4			13.2			16.0	
Peak Hour Factor	0.88	0.88	0.88	0.88	0.88	0.88	0.88	0.88	0.88	0.88	0.88	0.88
Shared Lane Traffic (%)												
Sign Control		Stop			Stop			Stop			Stop	
<b>Intersection Summary</b>												
Area Type:	Other											
Control Type:	Unsignalized											

Intersection	
Intersection Delay, s/veh	13.2
Intersection LOS	B



















Movement	EBL	EBT	EBR	WBL	WBT	WBR	NBL	NBT	NBR	SBL	SBT	SBR
Lane Configurations		↔	↔		↔			↔	↔		↔↔	↔
Traffic Vol, veh/h	41	26	10	9	20	37	23	287	2	11	247	51
Future Vol, veh/h	41	26	10	9	20	37	23	287	2	11	247	51
Peak Hour Factor	0.88	0.88	0.88	0.88	0.88	0.88	0.88	0.88	0.88	0.88	0.88	0.88
Heavy Vehicles, %	2	2	2	2	2	2	2	2	2	2	2	2
Mvmt Flow	47	30	11	10	23	42	26	326	2	13	281	58
Number of Lanes	0	1	1	0	1	0	0	1	1	0	2	1

Approach	EB	WB	NB	SB
Opposing Approach	WB	EB	SB	NB
Opposing Lanes	1	2	3	2
Conflicting Approach Left	SB	NB	EB	WB
Conflicting Lanes Left	3	2	2	1
Conflicting Approach Right	NB	SB	WB	EB
Conflicting Lanes Right	2	3	1	2
HCM Control Delay	10.9	10.4	16.9	10.7
HCM LOS	B	B	C	B

Lane	NBLn1	NBLn2	EBLn1	EBLn2	WBLn1	SBLn1	SBLn2	SBLn3
Vol Left, %	7%	0%	61%	0%	14%	12%	0%	0%
Vol Thru, %	93%	0%	39%	0%	30%	88%	100%	0%
Vol Right, %	0%	100%	0%	100%	56%	0%	0%	100%
Sign Control	Stop	Stop	Stop	Stop	Stop	Stop	Stop	Stop
Traffic Vol by Lane	310	2	67	10	66	93	165	51
LT Vol	23	0	41	0	9	11	0	0
Through Vol	287	0	26	0	20	82	165	0
RT Vol	0	2	0	10	37	0	0	51
Lane Flow Rate	352	2	76	11	75	106	187	58
Geometry Grp	8	8	8	8	8	8	8	8
Degree of Util (X)	0.587	0.003	0.152	0.019	0.137	0.18	0.315	0.086
Departure Headway (Hd)	6.002	5.259	7.177	6.16	6.587	6.112	6.053	5.346
Convergence, Y/N	Yes	Yes	Yes	Yes	Yes	Yes	Yes	Yes
Cap	602	680	499	579	543	587	593	669
Service Time	3.74	2.996	4.933	3.916	4.344	3.855	3.795	3.088
HCM Lane V/C Ratio	0.585	0.003	0.152	0.019	0.138	0.181	0.315	0.087
HCM Control Delay	17	8	11.2	9	10.4	10.2	11.6	8.6
HCM Lane LOS	C	A	B	A	B	B	B	A
HCM 95th-tile Q	3.8	0	0.5	0.1	0.5	0.7	1.3	0.3

Lanes, Volumes, Timings  
3: Mt. Vernon Ave. & Main St.

EAPC (2022) Conditions With Improvements  
AM PEAK HOUR

												
Lane Group	EBL	EBT	EBR	WBL	WBT	WBR	NBL	NBT	NBR	SBL	SBT	SBR
Lane Configurations												
Traffic Volume (vph)	41	26	10	9	20	37	23	287	2	11	247	51
Future Volume (vph)	41	26	10	9	20	37	23	287	2	11	247	51
Ideal Flow (vphpl)	1900	1900	1900	1900	1900	1900	1900	1900	1900	1900	1900	1900
Storage Length (ft)	0		50	0		0	0		50	0		50
Storage Lanes	0		1	0		0	0		0	0		1
Taper Length (ft)	90			90			90			90		
Link Speed (mph)		40			40			40			40	
Link Distance (ft)		1252			1253			777			936	
Travel Time (s)		21.3			21.4			13.2			16.0	
Peak Hour Factor	0.88	0.88	0.88	0.88	0.88	0.88	0.88	0.88	0.88	0.88	0.88	0.88
Shared Lane Traffic (%)												
Sign Control		Stop			Stop			Stop			Stop	
<b>Intersection Summary</b>												
Area Type:	Other											
Control Type:	Unsignalized											

Intersection	
Intersection Delay, s/veh	10.8
Intersection LOS	B

Movement	EBL	EBT	EBR	WBL	WBT	WBR	NBL	NBT	NBR	SBL	SBT	SBR
Lane Configurations		↖	↗		↔			↔			↖	↗
Traffic Vol, veh/h	41	26	10	9	20	37	23	287	2	11	247	51
Future Vol, veh/h	41	26	10	9	20	37	23	287	2	11	247	51
Peak Hour Factor	0.88	0.88	0.88	0.88	0.88	0.88	0.88	0.88	0.88	0.88	0.88	0.88
Heavy Vehicles, %	2	2	2	2	2	2	2	2	2	2	2	2
Mvmt Flow	47	30	11	10	23	42	26	326	2	13	281	58
Number of Lanes	0	1	1	0	1	0	0	2	0	0	2	1

Approach	EB	WB	NB	SB
Opposing Approach	WB	EB	SB	NB
Opposing Lanes	1	2	3	2
Conflicting Approach Left	SB	NB	EB	WB
Conflicting Lanes Left	3	2	2	1
Conflicting Approach Right	NB	SB	WB	EB
Conflicting Lanes Right	2	3	1	2
HCM Control Delay	10.8	10.2	11.2	10.5
HCM LOS	B	B	B	B

Lane	NBLn1	NBLn2	EBLn1	EBLn2	WBLn1	SBLn1	SBLn2	SBLn3
Vol Left, %	14%	0%	61%	0%	14%	12%	0%	0%
Vol Thru, %	86%	99%	39%	0%	30%	88%	100%	0%
Vol Right, %	0%	1%	0%	100%	56%	0%	0%	100%
Sign Control	Stop	Stop	Stop	Stop	Stop	Stop	Stop	Stop
Traffic Vol by Lane	167	146	67	10	66	93	165	51
LT Vol	23	0	41	0	9	11	0	0
Through Vol	144	144	26	0	20	82	165	0
RT Vol	0	2	0	10	37	0	0	51
Lane Flow Rate	189	165	76	11	75	106	187	58
Geometry Grp	8	8	8	8	8	8	8	8
Degree of Util (X)	0.316	0.273	0.149	0.019	0.135	0.178	0.311	0.085
Departure Headway (Hd)	6.021	5.941	7.068	6.053	6.482	6.042	5.983	5.276
Convergence, Y/N	Yes	Yes	Yes	Yes	Yes	Yes	Yes	Yes
Cap	598	605	507	590	553	594	601	679
Service Time	3.752	3.673	4.816	3.801	4.228	3.776	3.716	3.009
HCM Lane V/C Ratio	0.316	0.273	0.15	0.019	0.136	0.178	0.311	0.085
HCM Control Delay	11.5	10.9	11.1	8.9	10.2	10.1	11.4	8.5
HCM Lane LOS	B	B	B	A	B	B	B	A
HCM 95th-tile Q	1.4	1.1	0.5	0.1	0.5	0.6	1.3	0.3

Lanes, Volumes, Timings  
4: Mt. Vernon Ave. & Spring St.

EAPC (2022) Conditions  
AM PEAK HOUR

Lane Group	EBL	EBT	EBR	WBL	WBT	WBR	NBL	NBT	NBR	SBL	SBT	SBR
Lane Configurations												
Traffic Volume (vph)	12	7	9	23	23	95	7	161	9	28	195	21
Future Volume (vph)	12	7	9	23	23	95	7	161	9	28	195	21
Ideal Flow (vphpl)	1900	1900	1900	1900	1900	1900	1900	1900	1900	1900	1900	1900
Storage Length (ft)	140		0	165		0	200		0	205		205
Storage Lanes	1		0	1		0	1		0	1		1
Taper Length (ft)	90			60			90			90		
Right Turn on Red			Yes			Yes			Yes			Yes
Link Speed (mph)		30			30			40			40	
Link Distance (ft)		549			688			569			394	
Travel Time (s)		12.5			15.6			9.7			6.7	
Peak Hour Factor	0.79	0.79	0.79	0.79	0.79	0.79	0.79	0.79	0.79	0.79	0.79	0.79
Shared Lane Traffic (%)												
Turn Type	Prot	NA		Prot	NA		Prot	NA		Prot	NA	Perm
Protected Phases	7	4		3	8		5	2		1	6	
Permitted Phases												6
Detector Phase	7	4		3	8		5	2		1	6	6
Switch Phase												
Minimum Initial (s)	4.0	4.0		4.0	4.0		4.0	4.0		4.0	4.0	4.0
Minimum Split (s)	8.0	22.0		8.0	22.0		8.0	22.0		8.0	22.0	22.0
Total Split (s)	8.0	22.0		8.0	22.0		8.0	22.0		8.0	22.0	22.0
Total Split (%)	13.3%	36.7%		13.3%	36.7%		13.3%	36.7%		13.3%	36.7%	36.7%
Yellow Time (s)	3.5	3.5		3.5	3.5		3.5	3.5		3.5	3.5	3.5
All-Red Time (s)	0.5	0.5		0.5	0.5		0.5	0.5		0.5	0.5	0.5
Lost Time Adjust (s)	0.0	0.0		0.0	0.0		0.0	0.0		0.0	0.0	0.0
Total Lost Time (s)	4.0	4.0		4.0	4.0		4.0	4.0		4.0	4.0	4.0
Lead/Lag	Lead	Lag		Lead	Lag		Lead	Lead		Lag	Lag	Lag
Lead-Lag Optimize?	Yes	Yes		Yes	Yes		Yes	Yes		Yes	Yes	Yes
Recall Mode	None	None		None	None		None	C-Max		None	C-Max	C-Max

Intersection Summary





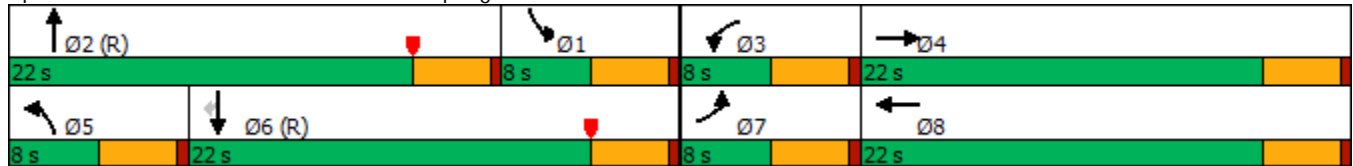

















Area Type: Other  
 Cycle Length: 60  
 Actuated Cycle Length: 60  
 Offset: 8 (13%), Referenced to phase 2:NBT and 6:SBT, Start of Yellow  
 Natural Cycle: 60  
 Control Type: Actuated-Coordinated

Splits and Phases: 4: Mt. Vernon Ave. & Spring St.



HCM 6th Signalized Intersection Summary  
4: Mt. Vernon Ave. & Spring St.

EAPC (2022) Conditions  
AM PEAK HOUR

												
Movement	EBL	EBT	EBR	WBL	WBT	WBR	NBL	NBT	NBR	SBL	SBT	SBR
Lane Configurations												
Traffic Volume (veh/h)	12	7	9	23	23	95	7	161	9	28	195	21
Future Volume (veh/h)	12	7	9	23	23	95	7	161	9	28	195	21
Initial Q (Qb), veh	0	0	0	0	0	0	0	0	0	0	0	0
Ped-Bike Adj(A_pbT)	1.00		1.00	1.00		1.00	1.00		1.00	1.00		1.00
Parking Bus, Adj	1.00	1.00	1.00	1.00	1.00	1.00	1.00	1.00	1.00	1.00	1.00	1.00
Work Zone On Approach		No			No			No			No	
Adj Sat Flow, veh/h/ln	1870	1870	1870	1870	1870	1870	1870	1870	1870	1870	1870	1870
Adj Flow Rate, veh/h	15	9	11	29	29	120	9	204	11	35	247	27
Peak Hour Factor	0.79	0.79	0.79	0.79	0.79	0.79	0.79	0.79	0.79	0.79	0.79	0.79
Percent Heavy Veh, %	2	2	2	2	2	2	2	2	2	2	2	2
Cap, veh/h	26	88	107	46	40	165	17	1029	55	522	1092	925
Arrive On Green	0.01	0.11	0.11	0.03	0.13	0.13	0.01	0.30	0.30	0.29	0.58	0.58
Sat Flow, veh/h	1781	766	936	1781	318	1316	1781	3430	184	1781	1870	1585
Grp Volume(v), veh/h	15	0	20	29	0	149	9	105	110	35	247	27
Grp Sat Flow(s),veh/h/ln	1781	0	1702	1781	0	1634	1781	1777	1837	1781	1870	1585
Q Serve(g_s), s	0.5	0.0	0.6	1.0	0.0	5.3	0.3	2.6	2.7	0.9	3.8	0.4
Cycle Q Clear(g_c), s	0.5	0.0	0.6	1.0	0.0	5.3	0.3	2.6	2.7	0.9	3.8	0.4
Prop In Lane	1.00		0.55	1.00		0.81	1.00		0.10	1.00		1.00
Lane Grp Cap(c), veh/h	26	0	195	46	0	205	17	533	551	522	1092	925
V/C Ratio(X)	0.57	0.00	0.10	0.64	0.00	0.73	0.54	0.20	0.20	0.07	0.23	0.03
Avail Cap(c_a), veh/h	119	0	511	119	0	490	119	533	551	522	1092	925
HCM Platoon Ratio	1.00	1.00	1.00	1.00	1.00	1.00	1.00	1.00	1.00	1.00	1.00	1.00
Upstream Filter(I)	1.00	0.00	1.00	1.00	0.00	1.00	1.00	1.00	1.00	1.00	1.00	1.00
Uniform Delay (d), s/veh	29.4	0.0	23.8	29.0	0.0	25.2	29.6	15.6	15.6	15.3	6.0	5.3
Incr Delay (d2), s/veh	18.0	0.0	0.2	13.8	0.0	4.9	25.0	0.8	0.8	0.1	0.5	0.1
Initial Q Delay(d3),s/veh	0.0	0.0	0.0	0.0	0.0	0.0	0.0	0.0	0.0	0.0	0.0	0.0
%ile BackOfQ(50%),veh/ln	0.3	0.0	0.3	0.6	0.0	2.2	0.2	1.0	1.1	0.3	1.2	0.1
Unsig. Movement Delay, s/veh												
LnGrp Delay(d),s/veh	47.4	0.0	24.0	42.8	0.0	30.1	54.6	16.5	16.4	15.3	6.5	5.3
LnGrp LOS	D	A	C	D	A	C	D	B	B	B	A	A
Approach Vol, veh/h		35			178			224			309	
Approach Delay, s/veh		34.0			32.2			18.0			7.4	
Approach LOS		C			C			B			A	
Timer - Assigned Phs	1	2	3	4	5	6	7	8				
Phs Duration (G+Y+Rc), s	21.6	22.0	5.5	10.9	4.6	39.0	4.9	11.5				
Change Period (Y+Rc), s	4.0	4.0	4.0	4.0	4.0	4.0	4.0	4.0				
Max Green Setting (Gmax), s	4.0	18.0	4.0	18.0	4.0	18.0	4.0	18.0				
Max Q Clear Time (g_c+I1), s	2.9	4.7	3.0	2.6	2.3	5.8	2.5	7.3				
Green Ext Time (p_c), s	0.0	0.8	0.0	0.0	0.0	1.0	0.0	0.5				
<b>Intersection Summary</b>												
HCM 6th Ctrl Delay				17.7								
HCM 6th LOS				B								

Lanes, Volumes, Timings  
 5: Mt. Vernon Ave. & Project Dwy. 1

EAPC (2022) Conditions  
 AM PEAK HOUR



Lane Group	WBL	WBR	NBT	NBR	SBL	SBT
Lane Configurations						
Traffic Volume (vph)	44	39	278	52	33	211
Future Volume (vph)	44	39	278	52	33	211
Ideal Flow (vphpl)	1900	1900	1900	1900	1900	1900
Link Speed (mph)	30		40			40
Link Distance (ft)	206		287			777
Travel Time (s)	4.7		4.9			13.2
Peak Hour Factor	0.92	0.92	0.92	0.92	0.92	0.92
Shared Lane Traffic (%)						
Sign Control	Stop		Free			Free

Intersection Summary

Area Type: Other  
 Control Type: Unsignalized

Intersection						
Int Delay, s/veh	2					
Movement	WBL	WBR	NBT	NBR	SBL	SBT
Lane Configurations	TT		T			TT
Traffic Vol, veh/h	44	39	278	52	33	211
Future Vol, veh/h	44	39	278	52	33	211
Conflicting Peds, #/hr	0	0	0	0	0	0
Sign Control	Stop	Stop	Free	Free	Free	Free
RT Channelized	-	None	-	None	-	None
Storage Length	0	-	-	-	-	-
Veh in Median Storage, #	0	-	0	-	-	0
Grade, %	0	-	0	-	-	0
Peak Hour Factor	92	92	92	92	92	92
Heavy Vehicles, %	2	2	2	2	2	2
Mvmt Flow	48	42	302	57	36	229

Major/Minor	Minor1	Major1	Major2		
Conflicting Flow All	518	331	0	0	359
Stage 1	331	-	-	-	-
Stage 2	187	-	-	-	-
Critical Hdwy	6.63	6.23	-	-	4.13
Critical Hdwy Stg 1	5.43	-	-	-	-
Critical Hdwy Stg 2	5.83	-	-	-	-
Follow-up Hdwy	3.519	3.319	-	-	2.219
Pot Cap-1 Maneuver	502	710	-	-	1198
Stage 1	727	-	-	-	-
Stage 2	827	-	-	-	-
Platoon blocked, %			-	-	-
Mov Cap-1 Maneuver	485	710	-	-	1198
Mov Cap-2 Maneuver	485	-	-	-	-
Stage 1	702	-	-	-	-
Stage 2	827	-	-	-	-

Approach	WB	NB	SB
HCM Control Delay, s	12.5	0	1.1
HCM LOS	B		

Minor Lane/Major Mvmt	NBT	NBRWBLn1	SBL	SBT
Capacity (veh/h)	-	-	570	1198
HCM Lane V/C Ratio	-	-	0.158	0.03
HCM Control Delay (s)	-	-	12.5	8.1
HCM Lane LOS	-	-	B	A
HCM 95th %tile Q(veh)	-	-	0.6	0.1

Lanes, Volumes, Timings  
6: Mt. Vernon Ave. & Project Dwy. 2

EAPC (2022) Conditions  
AM PEAK HOUR



Lane Group	WBL	WBR	NBT	NBR	SBL	SBT
Lane Configurations						
Traffic Volume (vph)	0	29	301	39	0	255
Future Volume (vph)	0	29	301	39	0	255
Ideal Flow (vphpl)	1900	1900	1900	1900	1900	1900
Link Speed (mph)	30		40			40
Link Distance (ft)	217		254			287
Travel Time (s)	4.9		4.3			4.9
Peak Hour Factor	0.92	0.92	0.92	0.92	0.92	0.92
Shared Lane Traffic (%)						
Sign Control	Stop		Free			Free

Intersection Summary

Area Type: Other  
Control Type: Unsignalized

Intersection						
Int Delay, s/veh	0.5					
Movement	WBL	WBR	NBT	NBR	SBL	SBT
Lane Configurations		↗	↘			↕↕
Traffic Vol, veh/h	0	29	301	39	0	255
Future Vol, veh/h	0	29	301	39	0	255
Conflicting Peds, #/hr	0	0	0	0	0	0
Sign Control	Stop	Stop	Free	Free	Free	Free
RT Channelized	-	None	-	None	-	None
Storage Length	-	0	-	-	-	-
Veh in Median Storage, #	0	-	0	-	-	0
Grade, %	0	-	0	-	-	0
Peak Hour Factor	92	92	92	92	92	92
Heavy Vehicles, %	2	2	2	2	2	2
Mvmt Flow	0	32	327	42	0	277

Major/Minor	Minor1	Major1	Major2		
Conflicting Flow All	-	348	0	0	-
Stage 1	-	-	-	-	-
Stage 2	-	-	-	-	-
Critical Hdwy	-	6.23	-	-	-
Critical Hdwy Stg 1	-	-	-	-	-
Critical Hdwy Stg 2	-	-	-	-	-
Follow-up Hdwy	-	3.319	-	-	-
Pot Cap-1 Maneuver	0	694	-	-	0
Stage 1	0	-	-	-	0
Stage 2	0	-	-	-	0
Platoon blocked, %			-	-	-
Mov Cap-1 Maneuver	-	694	-	-	-
Mov Cap-2 Maneuver	-	-	-	-	-
Stage 1	-	-	-	-	-
Stage 2	-	-	-	-	-

Approach	WB	NB	SB
HCM Control Delay, s	10.4	0	0
HCM LOS	B		

Minor Lane/Major Mvmt	NBT	NBRWBLn1	SBT
Capacity (veh/h)	-	-	694
HCM Lane V/C Ratio	-	-	0.045
HCM Control Delay (s)	-	-	10.4
HCM Lane LOS	-	-	B
HCM 95th %tile Q(veh)	-	-	0.1

Lanes, Volumes, Timings  
 7: Center St. & Project Dwy. 3

EAPC (2022) Conditions  
 AM PEAK HOUR

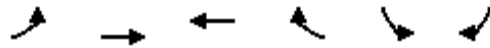

Lane Group	EBL	EBT	WBT	WBR	SBL	SBR
Lane Configurations		↑	↑			↑
Traffic Volume (vph)	0	97	213	7	0	16
Future Volume (vph)	0	97	213	7	0	16
Ideal Flow (vphpl)	1900	1900	1900	1900	1900	1900
Link Speed (mph)		40	40		30	
Link Distance (ft)		105	264		189	
Travel Time (s)		1.8	4.5		4.3	
Peak Hour Factor	0.92	0.92	0.92	0.92	0.92	0.92
Shared Lane Traffic (%)						
Sign Control		Free	Free		Stop	

Intersection Summary

Area Type: Other  
 Control Type: Unsignalized

Intersection						
Int Delay, s/veh	0.5					
Movement	EBL	EBT	WBT	WBR	SBL	SBR
Lane Configurations		↑	↑			↑
Traffic Vol, veh/h	0	97	213	7	0	16
Future Vol, veh/h	0	97	213	7	0	16
Conflicting Peds, #/hr	0	0	0	0	0	0
Sign Control	Free	Free	Free	Free	Stop	Stop
RT Channelized	-	None	-	None	-	None
Storage Length	-	-	-	-	-	0
Veh in Median Storage, #	-	0	0	-	0	-
Grade, %	-	0	0	-	0	-
Peak Hour Factor	92	92	92	92	92	92
Heavy Vehicles, %	2	2	2	2	2	2
Mvmt Flow	0	105	232	8	0	17

Major/Minor	Major1	Major2	Minor2
Conflicting Flow All	-	0	-
Stage 1	-	-	-
Stage 2	-	-	-
Critical Hdwy	-	-	-
Critical Hdwy Stg 1	-	-	-
Critical Hdwy Stg 2	-	-	-
Follow-up Hdwy	-	-	-
Pot Cap-1 Maneuver	0	-	-
Stage 1	0	-	-
Stage 2	0	-	-
Platoon blocked, %	-	-	-
Mov Cap-1 Maneuver	-	-	-
Mov Cap-2 Maneuver	-	-	-
Stage 1	-	-	-
Stage 2	-	-	-

Approach	EB	WB	SB
HCM Control Delay, s	0	0	9.6
HCM LOS			A

Minor Lane/Major Mvmt	EBT	WBT	WBR	SBLn1
Capacity (veh/h)	-	-	-	803
HCM Lane V/C Ratio	-	-	-	0.022
HCM Control Delay (s)	-	-	-	9.6
HCM Lane LOS	-	-	-	A
HCM 95th %tile Q(veh)	-	-	-	0.1

Lanes, Volumes, Timings  
 8: Center St. & Project Dwy. 4

EAPC (2022) Conditions  
 AM PEAK HOUR

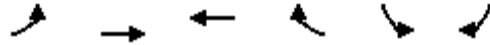

Lane Group	EBL	EBT	WBT	WBR	SBL	SBR
Lane Configurations		↑	↑		↑	
Traffic Volume (vph)	10	87	192	1	1	28
Future Volume (vph)	10	87	192	1	1	28
Ideal Flow (vphpl)	1900	1900	1900	1900	1900	1900
Link Speed (mph)		40	40		30	
Link Distance (ft)		264	515		187	
Travel Time (s)		4.5	8.8		4.3	
Peak Hour Factor	0.92	0.92	0.92	0.92	0.92	0.92
Shared Lane Traffic (%)						
Sign Control		Free	Free		Stop	

Intersection Summary

Area Type: Other  
 Control Type: Unsignalized

Intersection						
Int Delay, s/veh	1.1					
Movement	EBL	EBT	WBT	WBR	SBL	SBR
Lane Configurations		↑	↑		↑	
Traffic Vol, veh/h	10	87	192	1	1	28
Future Vol, veh/h	10	87	192	1	1	28
Conflicting Peds, #/hr	0	0	0	0	0	0
Sign Control	Free	Free	Free	Free	Stop	Stop
RT Channelized	-	None	-	None	-	None
Storage Length	-	-	-	-	0	-
Veh in Median Storage, #	-	0	0	-	0	-
Grade, %	-	0	0	-	0	-
Peak Hour Factor	92	92	92	92	92	92
Heavy Vehicles, %	2	2	2	2	2	2
Mvmt Flow	11	95	209	1	1	30

Major/Minor	Major1	Major2	Minor2		
Conflicting Flow All	210	0	-	0	327 210
Stage 1	-	-	-	-	210 -
Stage 2	-	-	-	-	117 -
Critical Hdwy	4.12	-	-	-	6.42 6.22
Critical Hdwy Stg 1	-	-	-	-	5.42 -
Critical Hdwy Stg 2	-	-	-	-	5.42 -
Follow-up Hdwy	2.218	-	-	-	3.518 3.318
Pot Cap-1 Maneuver	1361	-	-	-	667 830
Stage 1	-	-	-	-	825 -
Stage 2	-	-	-	-	908 -
Platoon blocked, %		-	-	-	
Mov Cap-1 Maneuver	1361	-	-	-	661 830
Mov Cap-2 Maneuver	-	-	-	-	661 -
Stage 1	-	-	-	-	818 -
Stage 2	-	-	-	-	908 -

Approach	EB	WB	SB
HCM Control Delay, s	0.8	0	9.5
HCM LOS			A

Minor Lane/Major Mvmt	EBL	EBT	WBT	WBR	SBLn1
Capacity (veh/h)	1361	-	-	-	823
HCM Lane V/C Ratio	0.008	-	-	-	0.038
HCM Control Delay (s)	7.7	-	-	-	9.5
HCM Lane LOS	A	-	-	-	A
HCM 95th %tile Q(veh)	0	-	-	-	0.1

Lanes, Volumes, Timings  
1: Mt. Vernon Ave. & Center St.

EAPC (2022) Conditions  
PM PEAK HOUR

Lane Group	EBL	EBT	EBR	WBL	WBT	WBR	NBL	NBT	NBR	SBL	SBT	SBR
Lane Configurations												
Traffic Volume (vph)	118	80	19	26	72	40	17	302	17	56	258	107
Future Volume (vph)	118	80	19	26	72	40	17	302	17	56	258	107
Ideal Flow (vphpl)	1900	1900	1900	1900	1900	1900	1900	1900	1900	1900	1900	1900
Storage Length (ft)	185		0	150		150	210		210	150		0
Storage Lanes	1		0	1		0	1		1	1		0
Taper Length (ft)	90			60			60			90		
Right Turn on Red			Yes			Yes			Yes			Yes
Link Speed (mph)		40			40			40			40	
Link Distance (ft)		2630			193			444			254	
Travel Time (s)		44.8			3.3			7.6			4.3	
Peak Hour Factor	0.90	0.90	0.90	0.90	0.90	0.90	0.90	0.90	0.90	0.90	0.90	0.90
Shared Lane Traffic (%)												
Turn Type	Prot	NA		Prot	NA		Prot	NA	Perm	Prot	NA	
Protected Phases	7	4		3	8		5	2		1	6	
Permitted Phases									2			
Detector Phase	7	4		3	8		5	2	2	1	6	
Switch Phase												
Minimum Initial (s)	4.0	4.0		4.0	4.0		4.0	4.0	4.0	4.0	4.0	
Minimum Split (s)	8.0	22.0		8.0	22.0		8.0	22.0	22.0	8.0	22.0	
Total Split (s)	8.0	22.0		8.0	22.0		8.0	22.0	22.0	8.0	22.0	
Total Split (%)	13.3%	36.7%		13.3%	36.7%		13.3%	36.7%	36.7%	13.3%	36.7%	
Yellow Time (s)	3.5	3.5		3.5	3.5		3.5	3.5	3.5	3.5	3.5	
All-Red Time (s)	0.5	0.5		0.5	0.5		0.5	0.5	0.5	0.5	0.5	
Lost Time Adjust (s)	0.0	0.0		0.0	0.0		0.0	0.0	0.0	0.0	0.0	
Total Lost Time (s)	4.0	4.0		4.0	4.0		4.0	4.0	4.0	4.0	4.0	
Lead/Lag	Lead	Lag		Lead	Lag		Lead	Lag	Lag	Lead	Lag	
Lead-Lag Optimize?	Yes	Yes		Yes	Yes		Yes	Yes	Yes	Yes	Yes	
Recall Mode	None	None		None	None		None	C-Max	C-Max	None	C-Max	

Intersection Summary

Area Type: Other  
 Cycle Length: 60  
 Actuated Cycle Length: 60  
 Offset: 0 (0%), Referenced to phase 2:NBT and 6:SBT, Start of Yellow  
 Natural Cycle: 60  
 Control Type: Actuated-Coordinated

Splits and Phases: 1: Mt. Vernon Ave. & Center St.

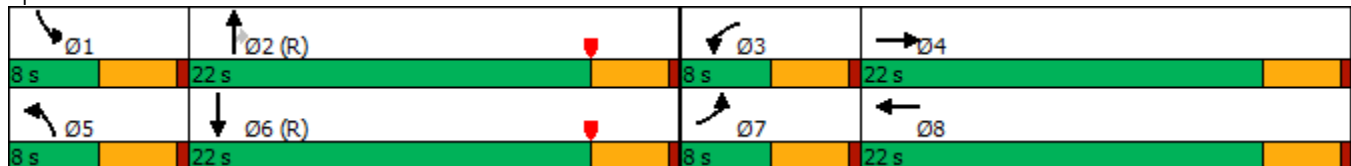

HCM 6th Signalized Intersection Summary  
 1: Mt. Vernon Ave. & Center St.



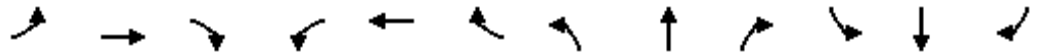





















EAPC (2022) Conditions  
 PM PEAK HOUR



Movement	EBL	EBT	EBR	WBL	WBT	WBR	NBL	NBT	NBR	SBL	SBT	SBR
Lane Configurations	↖	↕		↖	↕		↖	↕	↗	↖	↕	↗
Traffic Volume (veh/h)	118	80	19	26	72	40	17	302	17	56	258	107
Future Volume (veh/h)	118	80	19	26	72	40	17	302	17	56	258	107
Initial Q (Qb), veh	0	0	0	0	0	0	0	0	0	0	0	0
Ped-Bike Adj(A_pbT)	1.00		1.00	1.00		1.00	1.00		1.00	1.00		1.00
Parking Bus, Adj	1.00	1.00	1.00	1.00	1.00	1.00	1.00	1.00	1.00	1.00	1.00	1.00
Work Zone On Approach		No			No			No			No	
Adj Sat Flow, veh/h/ln	1870	1870	1870	1870	1870	1870	1870	1870	1870	1870	1870	1870
Adj Flow Rate, veh/h	131	89	21	29	80	44	19	336	19	62	287	119
Peak Hour Factor	0.90	0.90	0.90	0.90	0.90	0.90	0.90	0.90	0.90	0.90	0.90	0.90
Percent Heavy Veh, %	2	2	2	2	2	2	2	2	2	2	2	2
Cap, veh/h	119	336	77	46	172	88	32	1023	867	78	1414	572
Arrive On Green	0.07	0.12	0.12	0.03	0.08	0.08	0.02	0.55	0.55	0.04	0.57	0.57
Sat Flow, veh/h	1781	2872	657	1781	2272	1166	1781	1870	1585	1781	2468	999
Grp Volume(v), veh/h	131	54	56	29	61	63	19	336	19	62	205	201
Grp Sat Flow(s),veh/h/ln	1781	1777	1752	1781	1777	1661	1781	1870	1585	1781	1777	1690
Q Serve(g_s), s	4.0	1.7	1.7	1.0	2.0	2.2	0.6	5.9	0.3	2.1	3.3	3.5
Cycle Q Clear(g_c), s	4.0	1.7	1.7	1.0	2.0	2.2	0.6	5.9	0.3	2.1	3.3	3.5
Prop In Lane	1.00		0.37	1.00		0.70	1.00		1.00	1.00		0.59
Lane Grp Cap(c), veh/h	119	208	205	46	135	126	32	1023	867	78	1018	968
V/C Ratio(X)	1.10	0.26	0.27	0.64	0.46	0.50	0.59	0.33	0.02	0.80	0.20	0.21
Avail Cap(c_a), veh/h	119	533	526	119	533	498	119	1023	867	119	1018	968
HCM Platoon Ratio	1.00	1.00	1.00	1.00	1.00	1.00	1.00	1.00	1.00	1.00	1.00	1.00
Upstream Filter(I)	1.00	1.00	1.00	1.00	1.00	1.00	1.00	1.00	1.00	1.00	1.00	1.00
Uniform Delay (d), s/veh	28.0	24.1	24.2	29.0	26.5	26.6	29.2	7.5	6.2	28.4	6.2	6.2
Incr Delay (d2), s/veh	113.0	0.7	0.7	13.8	2.4	3.0	15.9	0.9	0.0	18.8	0.4	0.5
Initial Q Delay(d3),s/veh	0.0	0.0	0.0	0.0	0.0	0.0	0.0	0.0	0.0	0.0	0.0	0.0
%ile BackOfQ(50%),veh/ln	5.3	0.7	0.7	0.6	0.9	0.9	0.4	2.0	0.1	1.2	1.0	1.0
Unsig. Movement Delay, s/veh												
LnGrp Delay(d),s/veh	141.0	24.8	24.9	42.8	28.9	29.6	45.2	8.4	6.3	47.3	6.6	6.7
LnGrp LOS	F	C	C	D	C	C	D	A	A	D	A	A
Approach Vol, veh/h		241			153			374			468	
Approach Delay, s/veh		88.0			31.9			10.1			12.0	
Approach LOS		F			C			B			B	
Timer - Assigned Phs	1	2	3	4	5	6	7	8				
Phs Duration (G+Y+Rc), s	6.6	36.8	5.5	11.0	5.1	38.4	8.0	8.5				
Change Period (Y+Rc), s	4.0	4.0	4.0	4.0	4.0	4.0	4.0	4.0				
Max Green Setting (Gmax), s	4.0	18.0	4.0	18.0	4.0	18.0	4.0	18.0				
Max Q Clear Time (g_c+I1), s	4.1	7.9	3.0	3.7	2.6	5.5	6.0	4.2				
Green Ext Time (p_c), s	0.0	1.3	0.0	0.4	0.0	1.8	0.0	0.4				
<b>Intersection Summary</b>												
HCM 6th Ctrl Delay				28.7								
HCM 6th LOS				C								

Lanes, Volumes, Timings  
2: Michigan Ave. & Center St.

EAPC (2022) Conditions  
PM PEAK HOUR

												
Lane Group	EBL	EBT	EBR	WBL	WBT	WBR	NBL	NBT	NBR	SBL	SBT	SBR
Lane Configurations		 			 			 			 	
Traffic Volume (vph)	103	226	4	22	184	29	4	26	18	20	44	73
Future Volume (vph)	103	226	4	22	184	29	4	26	18	20	44	73
Ideal Flow (vphpl)	1900	1900	1900	1900	1900	1900	1900	1900	1900	1900	1900	1900
Storage Length (ft)	0		50	0		50	0		50	115		0
Storage Lanes	0		1	0		1	0		1	1		1
Taper Length (ft)	90			90			90			90		
Link Speed (mph)		40			40			30			30	
Link Distance (ft)		841			2630			440			477	
Travel Time (s)		14.3			44.8			10.0			10.8	
Peak Hour Factor	0.94	0.94	0.94	0.94	0.94	0.94	0.94	0.94	0.94	0.94	0.94	0.94
Shared Lane Traffic (%)												
Sign Control		Stop			Stop			Stop			Stop	
<b>Intersection Summary</b>												
Area Type:	Other											
Control Type:	Unsignalized											

Intersection	
Intersection Delay, s/veh	10.4
Intersection LOS	B



















Movement	EBL	EBT	EBR	WBL	WBT	WBR	NBL	NBT	NBR	SBL	SBT	SBR
Lane Configurations		↔↑	↔		↔↑	↔		↔	↔		↔	↔
Traffic Vol, veh/h	103	226	4	22	184	29	4	26	18	20	44	73
Future Vol, veh/h	103	226	4	22	184	29	4	26	18	20	44	73
Peak Hour Factor	0.94	0.94	0.94	0.94	0.94	0.94	0.94	0.94	0.94	0.94	0.94	0.94
Heavy Vehicles, %	2	2	2	2	2	2	2	2	2	2	2	2
Mvmt Flow	110	240	4	23	196	31	4	28	19	21	47	78
Number of Lanes	0	2	1	0	2	1	0	1	1	0	1	1

Approach	EB	WB	NB	SB
Opposing Approach	WB	EB	SB	NB
Opposing Lanes	3	3	2	2
Conflicting Approach Left	SB	NB	EB	WB
Conflicting Lanes Left	2	2	3	3
Conflicting Approach Right	NB	SB	WB	EB
Conflicting Lanes Right	2	2	3	3
HCM Control Delay	11.1	10	9.4	9.7
HCM LOS	B	A	A	A

Lane	NBLn1	NBLn2	EBLn1	EBLn2	EBLn3	WBLn1	WBLn2	WBLn3	SBLn1	SBLn2
Vol Left, %	13%	0%	58%	0%	0%	26%	0%	0%	31%	0%
Vol Thru, %	87%	0%	42%	100%	0%	74%	100%	0%	69%	0%
Vol Right, %	0%	100%	0%	0%	100%	0%	0%	100%	0%	100%
Sign Control	Stop	Stop	Stop	Stop	Stop	Stop	Stop	Stop	Stop	Stop
Traffic Vol by Lane	30	18	178	151	4	83	123	29	64	73
LT Vol	4	0	103	0	0	22	0	0	20	0
Through Vol	26	0	75	151	0	61	123	0	44	0
RT Vol	0	18	0	0	4	0	0	29	0	73
Lane Flow Rate	32	19	190	160	4	89	130	31	68	78
Geometry Grp	8	8	8	8	8	8	8	8	8	8
Degree of Util (X)	0.059	0.031	0.32	0.258	0.006	0.151	0.218	0.045	0.124	0.122
Departure Headway (Hd)	6.675	5.907	6.078	5.787	5.082	6.145	6.012	5.306	6.533	5.676
Convergence, Y/N	Yes	Yes	Yes	Yes	Yes	Yes	Yes	Yes	Yes	Yes
Cap	536	605	592	622	705	584	598	675	549	631
Service Time	4.417	3.648	3.804	3.513	2.808	3.874	3.741	3.035	4.267	3.41
HCM Lane V/C Ratio	0.06	0.031	0.321	0.257	0.006	0.152	0.217	0.046	0.124	0.124
HCM Control Delay	9.8	8.8	11.7	10.5	7.8	10	10.4	8.3	10.2	9.2
HCM Lane LOS	A	A	B	B	A	A	B	A	B	A
HCM 95th-tile Q	0.2	0.1	1.4	1	0	0.5	0.8	0.1	0.4	0.4

Lanes, Volumes, Timings  
3: Mt. Vernon Ave. & Main St.

EAPC (2022) Conditions  
PM PEAK HOUR

												
Lane Group	EBL	EBT	EBR	WBL	WBT	WBR	NBL	NBT	NBR	SBL	SBT	SBR
Lane Configurations												
Traffic Volume (vph)	56	63	12	4	43	26	9	416	19	42	398	48
Future Volume (vph)	56	63	12	4	43	26	9	416	19	42	398	48
Ideal Flow (vphpl)	1900	1900	1900	1900	1900	1900	1900	1900	1900	1900	1900	1900
Storage Length (ft)	0		50	0		0	0		50	0		50
Storage Lanes	0		1	0		0	0		1	0		1
Taper Length (ft)	90			90			90			90		
Link Speed (mph)		40			40			40			40	
Link Distance (ft)		1252			1253			777			936	
Travel Time (s)		21.3			21.4			13.2			16.0	
Peak Hour Factor	0.84	0.84	0.84	0.84	0.84	0.84	0.84	0.84	0.84	0.84	0.84	0.84
Shared Lane Traffic (%)												
Sign Control		Stop			Stop			Stop			Stop	
<b>Intersection Summary</b>												
Area Type:	Other											
Control Type:	Unsignalized											

Intersection	
Intersection Delay, s/veh	38.1
Intersection LOS	E



















Movement	EBL	EBT	EBR	WBL	WBT	WBR	NBL	NBT	NBR	SBL	SBT	SBR
Lane Configurations		↕	↕		↕			↕	↕		↕↕	↕
Traffic Vol, veh/h	56	63	12	4	43	26	9	416	19	42	398	48
Future Vol, veh/h	56	63	12	4	43	26	9	416	19	42	398	48
Peak Hour Factor	0.84	0.84	0.84	0.84	0.84	0.84	0.84	0.84	0.84	0.84	0.84	0.84
Heavy Vehicles, %	2	2	2	2	2	2	2	2	2	2	2	2
Mvmt Flow	67	75	14	5	51	31	11	495	23	50	474	57
Number of Lanes	0	1	1	0	1	0	0	1	1	0	2	1

Approach	EB	WB	NB	SB
Opposing Approach	WB	EB	SB	NB
Opposing Lanes	1	2	3	2
Conflicting Approach Left	SB	NB	EB	WB
Conflicting Lanes Left	3	2	2	1
Conflicting Approach Right	NB	SB	WB	EB
Conflicting Lanes Right	2	3	1	2
HCM Control Delay	15.7	13.7	69.9	18.8
HCM LOS	C	B	F	C

Lane	NBLn1	NBLn2	EBLn1	EBLn2	WBLn1	SBLn1	SBLn2	SBLn3
Vol Left, %	2%	0%	47%	0%	5%	24%	0%	0%
Vol Thru, %	98%	0%	53%	0%	59%	76%	100%	0%
Vol Right, %	0%	100%	0%	100%	36%	0%	0%	100%
Sign Control	Stop	Stop	Stop	Stop	Stop	Stop	Stop	Stop
Traffic Vol by Lane	425	19	119	12	73	175	265	48
LT Vol	9	0	56	0	4	42	0	0
Through Vol	416	0	63	0	43	133	265	0
RT Vol	0	19	0	12	26	0	0	48
Lane Flow Rate	506	23	142	14	87	208	316	57
Geometry Grp	8	8	8	8	8	8	8	8
Degree of Util (X)	1.02	0.041	0.343	0.031	0.206	0.43	0.643	0.105
Departure Headway (Hd)	7.259	6.534	8.901	7.866	8.735	7.453	7.33	6.615
Convergence, Y/N	Yes	Yes	Yes	Yes	Yes	Yes	Yes	Yes
Cap	501	548	407	454	414	482	493	541
Service Time	5.004	4.279	6.601	5.639	6.435	5.203	5.08	4.365
HCM Lane V/C Ratio	1.01	0.042	0.349	0.031	0.21	0.432	0.641	0.105
HCM Control Delay	72.6	9.6	16.2	10.9	13.7	15.7	22.4	10.1
HCM Lane LOS	F	A	C	B	B	C	C	B
HCM 95th-tile Q	14.4	0.1	1.5	0.1	0.8	2.1	4.5	0.3

Lanes, Volumes, Timings  
3: Mt. Vernon Ave. & Main St.

EAPC (2022) Conditions With Improvements  
PM PEAK HOUR

												
Lane Group	EBL	EBT	EBR	WBL	WBT	WBR	NBL	NBT	NBR	SBL	SBT	SBR
Lane Configurations												
Traffic Volume (vph)	56	63	12	4	43	26	9	416	19	42	398	48
Future Volume (vph)	56	63	12	4	43	26	9	416	19	42	398	48
Ideal Flow (vphpl)	1900	1900	1900	1900	1900	1900	1900	1900	1900	1900	1900	1900
Storage Length (ft)	0		50	0		0	0		50	0		50
Storage Lanes	0		1	0		0	0		0	0		1
Taper Length (ft)	90			90			90			90		
Link Speed (mph)		40			40			40			40	
Link Distance (ft)		1252			1253			777			936	
Travel Time (s)		21.3			21.4			13.2			16.0	
Peak Hour Factor	0.84	0.84	0.84	0.84	0.84	0.84	0.84	0.84	0.84	0.84	0.84	0.84
Shared Lane Traffic (%)												
Sign Control		Stop			Stop			Stop			Stop	
<b>Intersection Summary</b>												
Area Type:	Other											
Control Type:	Unsignalized											

Intersection	
Intersection Delay, s/veh	17.1
Intersection LOS	C

Movement	EBL	EBT	EBR	WBL	WBT	WBR	NBL	NBT	NBR	SBL	SBT	SBR
Lane Configurations		↕	↕		↕			↕			↕	↕
Traffic Vol, veh/h	56	63	12	4	43	26	9	416	19	42	398	48
Future Vol, veh/h	56	63	12	4	43	26	9	416	19	42	398	48
Peak Hour Factor	0.84	0.84	0.84	0.84	0.84	0.84	0.84	0.84	0.84	0.84	0.84	0.84
Heavy Vehicles, %	2	2	2	2	2	2	2	2	2	2	2	2
Mvmt Flow	67	75	14	5	51	31	11	495	23	50	474	57
Number of Lanes	0	1	1	0	1	0	0	2	0	0	2	1

Approach	EB	WB	NB	SB
Opposing Approach	WB	EB	SB	NB
Opposing Lanes	1	2	3	2
Conflicting Approach Left	SB	NB	EB	WB
Conflicting Lanes Left	3	2	2	1
Conflicting Approach Right	NB	SB	WB	EB
Conflicting Lanes Right	2	3	1	2
HCM Control Delay	15.1	13.2	17.6	17.7
HCM LOS	C	B	C	C

Lane	NBLn1	NBLn2	EBLn1	EBLn2	WBLn1	SBLn1	SBLn2	SBLn3
Vol Left, %	4%	0%	47%	0%	5%	24%	0%	0%
Vol Thru, %	96%	92%	53%	0%	59%	76%	100%	0%
Vol Right, %	0%	8%	0%	100%	36%	0%	0%	100%
Sign Control	Stop	Stop	Stop	Stop	Stop	Stop	Stop	Stop
Traffic Vol by Lane	217	227	119	12	73	175	265	48
LT Vol	9	0	56	0	4	42	0	0
Through Vol	208	208	63	0	43	133	265	0
RT Vol	0	19	0	12	26	0	0	48
Lane Flow Rate	258	270	142	14	87	208	316	57
Geometry Grp	8	8	8	8	8	8	8	8
Degree of Util (X)	0.517	0.534	0.336	0.03	0.201	0.417	0.622	0.101
Departure Headway (Hd)	7.198	7.117	8.527	7.571	8.34	7.214	7.091	6.378
Convergence, Y/N	Yes	Yes	Yes	Yes	Yes	Yes	Yes	Yes
Cap	501	505	422	472	429	499	509	561
Service Time	4.946	4.865	6.283	5.327	6.104	4.96	4.838	4.125
HCM Lane V/C Ratio	0.515	0.535	0.336	0.03	0.203	0.417	0.621	0.102
HCM Control Delay	17.4	17.8	15.6	10.6	13.2	15.1	20.9	9.8
HCM Lane LOS	C	C	C	B	B	C	C	A
HCM 95th-tile Q	2.9	3.1	1.5	0.1	0.7	2	4.2	0.3

Lanes, Volumes, Timings  
4: Mt. Vernon Ave. & Spring St.

EAPC (2022) Conditions  
PM PEAK HOUR

Lane Group	EBL	EBT	EBR	WBL	WBT	WBR	NBL	NBT	NBR	SBL	SBT	SBR
Lane Configurations												
Traffic Volume (vph)	14	21	5	26	15	60	11	273	33	88	210	8
Future Volume (vph)	14	21	5	26	15	60	11	273	33	88	210	8
Ideal Flow (vphpl)	1900	1900	1900	1900	1900	1900	1900	1900	1900	1900	1900	1900
Storage Length (ft)	140		0	165		0	200		0	205		205
Storage Lanes	1		0	1		0	1		0	1		1
Taper Length (ft)	90			60			90			90		
Right Turn on Red			Yes			Yes			Yes			Yes
Link Speed (mph)		30			30			40			40	
Link Distance (ft)		549			688			569			394	
Travel Time (s)		12.5			15.6			9.7			6.7	
Peak Hour Factor	0.91	0.91	0.91	0.91	0.91	0.91	0.91	0.91	0.91	0.91	0.91	0.91
Shared Lane Traffic (%)												
Turn Type	Prot	NA		Prot	NA		Prot	NA		Prot	NA	Perm
Protected Phases	7	4		3	8		5	2		1	6	
Permitted Phases												6
Detector Phase	7	4		3	8		5	2		1	6	6
Switch Phase												
Minimum Initial (s)	4.0	4.0		4.0	4.0		4.0	4.0		4.0	4.0	4.0
Minimum Split (s)	8.0	22.0		8.0	22.0		8.0	22.0		8.0	22.0	22.0
Total Split (s)	8.0	22.0		8.0	22.0		8.0	22.0		8.0	22.0	22.0
Total Split (%)	13.3%	36.7%		13.3%	36.7%		13.3%	36.7%		13.3%	36.7%	36.7%
Yellow Time (s)	3.5	3.5		3.5	3.5		3.5	3.5		3.5	3.5	3.5
All-Red Time (s)	0.5	0.5		0.5	0.5		0.5	0.5		0.5	0.5	0.5
Lost Time Adjust (s)	0.0	0.0		0.0	0.0		0.0	0.0		0.0	0.0	0.0
Total Lost Time (s)	4.0	4.0		4.0	4.0		4.0	4.0		4.0	4.0	4.0
Lead/Lag	Lead	Lag		Lead	Lag		Lag	Lead		Lag	Lead	Lead
Lead-Lag Optimize?	Yes	Yes		Yes	Yes		Yes	Yes		Yes	Yes	Yes
Recall Mode	None	None		None	None		None	C-Max		None	C-Max	C-Max

Intersection Summary





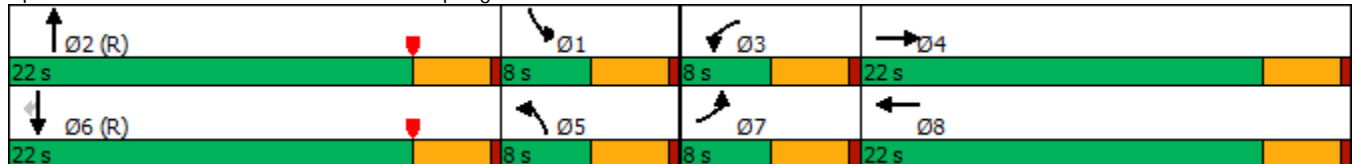

















Area Type: Other  
 Cycle Length: 60  
 Actuated Cycle Length: 60  
 Offset: 16 (27%), Referenced to phase 2:NBT and 6:SBT, Start of Yellow  
 Natural Cycle: 60  
 Control Type: Actuated-Coordinated

Splits and Phases: 4: Mt. Vernon Ave. & Spring St.



HCM 6th Signalized Intersection Summary  
4: Mt. Vernon Ave. & Spring St.

EAPC (2022) Conditions  
PM PEAK HOUR

												
Movement	EBL	EBT	EBR	WBL	WBT	WBR	NBL	NBT	NBR	SBL	SBT	SBR
Lane Configurations												
Traffic Volume (veh/h)	14	21	5	26	15	60	11	273	33	88	210	8
Future Volume (veh/h)	14	21	5	26	15	60	11	273	33	88	210	8
Initial Q (Qb), veh	0	0	0	0	0	0	0	0	0	0	0	0
Ped-Bike Adj(A_pbT)	1.00		1.00	1.00		1.00	1.00		1.00	1.00		1.00
Parking Bus, Adj	1.00	1.00	1.00	1.00	1.00	1.00	1.00	1.00	1.00	1.00	1.00	1.00
Work Zone On Approach		No			No			No			No	
Adj Sat Flow, veh/h/ln	1870	1870	1870	1870	1870	1870	1870	1870	1870	1870	1870	1870
Adj Flow Rate, veh/h	15	23	5	29	16	66	12	300	36	97	231	9
Peak Hour Factor	0.91	0.91	0.91	0.91	0.91	0.91	0.91	0.91	0.91	0.91	0.91	0.91
Percent Heavy Veh, %	2	2	2	2	2	2	2	2	2	2	2	2
Cap, veh/h	26	100	22	46	25	103	607	959	114	607	561	476
Arrive On Green	0.01	0.07	0.07	0.03	0.08	0.08	0.34	0.30	0.30	0.34	0.30	0.30
Sat Flow, veh/h	1781	1489	324	1781	319	1315	1781	3198	380	1781	1870	1585
Grp Volume(v), veh/h	15	0	28	29	0	82	12	165	171	97	231	9
Grp Sat Flow(s),veh/h/ln	1781	0	1812	1781	0	1634	1781	1777	1802	1781	1870	1585
Q Serve(g_s), s	0.5	0.0	0.9	1.0	0.0	2.9	0.3	4.3	4.4	2.3	5.9	0.2
Cycle Q Clear(g_c), s	0.5	0.0	0.9	1.0	0.0	2.9	0.3	4.3	4.4	2.3	5.9	0.2
Prop In Lane	1.00		0.18	1.00		0.80	1.00		0.21	1.00		1.00
Lane Grp Cap(c), veh/h	26	0	122	46	0	128	607	533	541	607	561	476
V/C Ratio(X)	0.57	0.00	0.23	0.64	0.00	0.64	0.02	0.31	0.32	0.16	0.41	0.02
Avail Cap(c_a), veh/h	119	0	544	119	0	490	607	533	541	607	561	476
HCM Platoon Ratio	1.00	1.00	1.00	1.00	1.00	1.00	1.00	1.00	1.00	1.00	1.00	1.00
Upstream Filter(I)	1.00	0.00	1.00	1.00	0.00	1.00	1.00	1.00	1.00	1.00	1.00	1.00
Uniform Delay (d), s/veh	29.4	0.0	26.5	29.0	0.0	26.8	13.1	16.2	16.2	13.8	16.8	9.2
Incr Delay (d2), s/veh	18.0	0.0	0.9	13.8	0.0	5.3	0.0	1.5	1.5	0.1	2.2	0.1
Initial Q Delay(d3),s/veh	0.0	0.0	0.0	0.0	0.0	0.0	0.0	0.0	0.0	0.0	0.0	0.0
%ile BackOfQ(50%),veh/ln	0.3	0.0	0.4	0.6	0.0	1.3	0.1	1.7	1.8	0.8	2.5	0.1
Unsig. Movement Delay, s/veh												
LnGrp Delay(d),s/veh	47.4	0.0	27.5	42.8	0.0	32.2	13.1	17.7	17.8	13.9	19.0	9.3
LnGrp LOS	D	A	C	D	A	C	B	B	B	B	B	A
Approach Vol, veh/h		43			111			348			337	
Approach Delay, s/veh		34.4			34.9			17.6			17.3	
Approach LOS		C			C			B			B	
Timer - Assigned Phs	1	2	3	4	5	6	7	8				
Phs Duration (G+Y+Rc), s	24.4	22.0	5.5	8.0	24.4	22.0	4.9	8.7				
Change Period (Y+Rc), s	4.0	4.0	4.0	4.0	4.0	4.0	4.0	4.0				
Max Green Setting (Gmax), s	4.0	18.0	4.0	18.0	4.0	18.0	4.0	18.0				
Max Q Clear Time (g_c+I1), s	4.3	6.4	3.0	2.9	2.3	7.9	2.5	4.9				
Green Ext Time (p_c), s	0.0	1.3	0.0	0.1	0.0	0.8	0.0	0.3				

Intersection Summary												
HCM 6th Ctrl Delay			20.6									
HCM 6th LOS			C									

Notes

User approved pedestrian interval to be less than phase max green.

Lanes, Volumes, Timings  
 5: Mt. Vernon Ave. & Project Dwy. 1

EAPC (2022) Conditions  
 PM PEAK HOUR



Lane Group	WBL	WBR	NBT	NBR	SBL	SBT
Lane Configurations						
Traffic Volume (vph)	54	47	387	61	39	366
Future Volume (vph)	54	47	387	61	39	366
Ideal Flow (vphpl)	1900	1900	1900	1900	1900	1900
Link Speed (mph)	30		40			40
Link Distance (ft)	206		287			777
Travel Time (s)	4.7		4.9			13.2
Peak Hour Factor	0.92	0.92	0.92	0.92	0.92	0.92
Shared Lane Traffic (%)						
Sign Control	Stop		Free			Free

Intersection Summary

Area Type: Other  
 Control Type: Unsignalized

Intersection						
Int Delay, s/veh	2					
Movement	WBL	WBR	NBT	NBR	SBL	SBT
Lane Configurations	Y		B			↑↑
Traffic Vol, veh/h	54	47	387	61	39	366
Future Vol, veh/h	54	47	387	61	39	366
Conflicting Peds, #/hr	0	0	0	0	0	0
Sign Control	Stop	Stop	Free	Free	Free	Free
RT Channelized	-	None	-	None	-	None
Storage Length	0	-	-	-	-	-
Veh in Median Storage, #	0	-	0	-	-	0
Grade, %	0	-	0	-	-	0
Peak Hour Factor	92	92	92	92	92	92
Heavy Vehicles, %	2	2	2	2	2	2
Mvmt Flow	59	51	421	66	42	398

Major/Minor	Minor1	Major1	Major2			
Conflicting Flow All	737	454	0	0	487	0
Stage 1	454	-	-	-	-	-
Stage 2	283	-	-	-	-	-
Critical Hdwy	6.63	6.23	-	-	4.13	-
Critical Hdwy Stg 1	5.43	-	-	-	-	-
Critical Hdwy Stg 2	5.83	-	-	-	-	-
Follow-up Hdwy	3.519	3.319	-	-	2.219	-
Pot Cap-1 Maneuver	369	605	-	-	1074	-
Stage 1	639	-	-	-	-	-
Stage 2	741	-	-	-	-	-
Platoon blocked, %			-	-	-	-
Mov Cap-1 Maneuver	351	605	-	-	1074	-
Mov Cap-2 Maneuver	351	-	-	-	-	-
Stage 1	607	-	-	-	-	-
Stage 2	741	-	-	-	-	-

Approach	WB	NB	SB
HCM Control Delay, s	16	0	0.8
HCM LOS	C		

Minor Lane/Major Mvmt	NBT	NBRWBLn1	SBL	SBT
Capacity (veh/h)	-	-	436	1074
HCM Lane V/C Ratio	-	-	0.252	0.039
HCM Control Delay (s)	-	-	16	8.5
HCM Lane LOS	-	-	C	A
HCM 95th %tile Q(veh)	-	-	1	0.1

Lanes, Volumes, Timings  
 6: Mt. Vernon Ave. & Project Dwy. 2

EAPC (2022) Conditions  
 PM PEAK HOUR



Lane Group	WBL	WBR	NBT	NBR	SBL	SBT
Lane Configurations						
Traffic Volume (vph)	0	35	413	46	0	420
Future Volume (vph)	0	35	413	46	0	420
Ideal Flow (vphpl)	1900	1900	1900	1900	1900	1900
Link Speed (mph)	30		40			40
Link Distance (ft)	217		254			287
Travel Time (s)	4.9		4.3			4.9
Peak Hour Factor	0.92	0.92	0.92	0.92	0.92	0.92
Shared Lane Traffic (%)						
Sign Control	Stop		Free			Free

Intersection Summary

Area Type: Other  
 Control Type: Unsignalized

Intersection						
Int Delay, s/veh	0.4					
Movement	WBL	WBR	NBT	NBR	SBL	SBT
Lane Configurations		↗	↘			↕↕
Traffic Vol, veh/h	0	35	413	46	0	420
Future Vol, veh/h	0	35	413	46	0	420
Conflicting Peds, #/hr	0	0	0	0	0	0
Sign Control	Stop	Stop	Free	Free	Free	Free
RT Channelized	-	None	-	None	-	None
Storage Length	-	0	-	-	-	-
Veh in Median Storage, #	0	-	0	-	-	0
Grade, %	0	-	0	-	-	0
Peak Hour Factor	92	92	92	92	92	92
Heavy Vehicles, %	2	2	2	2	2	2
Mvmt Flow	0	38	449	50	0	457

Major/Minor	Minor1	Major1	Major2		
Conflicting Flow All	-	474	0	0	-
Stage 1	-	-	-	-	-
Stage 2	-	-	-	-	-
Critical Hdwy	-	6.23	-	-	-
Critical Hdwy Stg 1	-	-	-	-	-
Critical Hdwy Stg 2	-	-	-	-	-
Follow-up Hdwy	-	3.319	-	-	-
Pot Cap-1 Maneuver	0	590	-	-	0
Stage 1	0	-	-	-	0
Stage 2	0	-	-	-	0
Platoon blocked, %			-	-	-
Mov Cap-1 Maneuver	-	590	-	-	-
Mov Cap-2 Maneuver	-	-	-	-	-
Stage 1	-	-	-	-	-
Stage 2	-	-	-	-	-

Approach	WB	NB	SB
HCM Control Delay, s	11.5	0	0
HCM LOS	B		

Minor Lane/Major Mvmt	NBT	NBRWBLn1	SBT
Capacity (veh/h)	-	-	590
HCM Lane V/C Ratio	-	-	0.064
HCM Control Delay (s)	-	-	11.5
HCM Lane LOS	-	-	B
HCM 95th %tile Q(veh)	-	-	0.2

Lanes, Volumes, Timings  
 7: Center St. & Project Dwy. 3

EAPC (2022) Conditions  
 PM PEAK HOUR

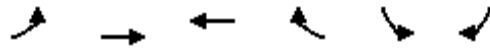

Lane Group	EBL	EBT	WBT	WBR	SBL	SBR
Lane Configurations		↑	↵			↶
Traffic Volume (vph)	0	153	117	8	0	20
Future Volume (vph)	0	153	117	8	0	20
Ideal Flow (vphpl)	1900	1900	1900	1900	1900	1900
Link Speed (mph)		40	40		30	
Link Distance (ft)		105	264		189	
Travel Time (s)		1.8	4.5		4.3	
Peak Hour Factor	0.92	0.92	0.92	0.92	0.92	0.92
Shared Lane Traffic (%)						
Sign Control		Free	Free		Stop	

Intersection Summary

Area Type: Other  
 Control Type: Unsignalized

Intersection						
Int Delay, s/veh	0.6					
Movement	EBL	EBT	WBT	WBR	SBL	SBR
Lane Configurations		↑	↑			↑
Traffic Vol, veh/h	0	153	117	8	0	20
Future Vol, veh/h	0	153	117	8	0	20
Conflicting Peds, #/hr	0	0	0	0	0	0
Sign Control	Free	Free	Free	Free	Stop	Stop
RT Channelized	-	None	-	None	-	None
Storage Length	-	-	-	-	-	0
Veh in Median Storage, #	-	0	0	-	0	-
Grade, %	-	0	0	-	0	-
Peak Hour Factor	92	92	92	92	92	92
Heavy Vehicles, %	2	2	2	2	2	2
Mvmt Flow	0	166	127	9	0	22

Major/Minor	Major1	Major2	Minor2
Conflicting Flow All	-	0	-
Stage 1	-	-	-
Stage 2	-	-	-
Critical Hdwy	-	-	-
Critical Hdwy Stg 1	-	-	-
Critical Hdwy Stg 2	-	-	-
Follow-up Hdwy	-	-	-
Pot Cap-1 Maneuver	0	-	-
Stage 1	0	-	-
Stage 2	0	-	-
Platoon blocked, %	-	-	-
Mov Cap-1 Maneuver	-	-	-
Mov Cap-2 Maneuver	-	-	-
Stage 1	-	-	-
Stage 2	-	-	-

Approach	EB	WB	SB
HCM Control Delay, s	0	0	9
HCM LOS			A

Minor Lane/Major Mvmt	EBT	WBT	WBR	SBLn1
Capacity (veh/h)	-	-	-	917
HCM Lane V/C Ratio	-	-	-	0.024
HCM Control Delay (s)	-	-	-	9
HCM Lane LOS	-	-	-	A
HCM 95th %tile Q(veh)	-	-	-	0.1

Lanes, Volumes, Timings  
 8: Center St. & Project Dwy. 4

EAPC (2022) Conditions  
 PM PEAK HOUR

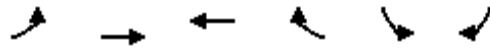

Lane Group	EBL	EBT	WBT	WBR	SBL	SBR
Lane Configurations		↑	↑		↑	
Traffic Volume (vph)	30	123	107	2	1	18
Future Volume (vph)	30	123	107	2	1	18
Ideal Flow (vphpl)	1900	1900	1900	1900	1900	1900
Link Speed (mph)		40	40		30	
Link Distance (ft)		264	515		187	
Travel Time (s)		4.5	8.8		4.3	
Peak Hour Factor	0.92	0.92	0.92	0.92	0.92	0.92
Shared Lane Traffic (%)						
Sign Control		Free	Free		Stop	

Intersection Summary

Area Type: Other  
 Control Type: Unsignalized

Intersection						
Int Delay, s/veh	1.4					
Movement	EBL	EBT	WBT	WBR	SBL	SBR
Lane Configurations		↑	↑		↑	
Traffic Vol, veh/h	30	123	107	2	1	18
Future Vol, veh/h	30	123	107	2	1	18
Conflicting Peds, #/hr	0	0	0	0	0	0
Sign Control	Free	Free	Free	Free	Stop	Stop
RT Channelized	-	None	-	None	-	None
Storage Length	-	-	-	-	0	-
Veh in Median Storage, #	-	0	0	-	0	-
Grade, %	-	0	0	-	0	-
Peak Hour Factor	92	92	92	92	92	92
Heavy Vehicles, %	2	2	2	2	2	2
Mvmt Flow	33	134	116	2	1	20

Major/Minor	Major1	Major2	Minor2		
Conflicting Flow All	118	0	-	0	317 117
Stage 1	-	-	-	-	117 -
Stage 2	-	-	-	-	200 -
Critical Hdwy	4.12	-	-	-	6.42 6.22
Critical Hdwy Stg 1	-	-	-	-	5.42 -
Critical Hdwy Stg 2	-	-	-	-	5.42 -
Follow-up Hdwy	2.218	-	-	-	3.518 3.318
Pot Cap-1 Maneuver	1470	-	-	-	676 935
Stage 1	-	-	-	-	908 -
Stage 2	-	-	-	-	834 -
Platoon blocked, %		-	-	-	
Mov Cap-1 Maneuver	1470	-	-	-	660 935
Mov Cap-2 Maneuver	-	-	-	-	660 -
Stage 1	-	-	-	-	886 -
Stage 2	-	-	-	-	834 -

Approach	EB	WB	SB
HCM Control Delay, s	1.5	0	9
HCM LOS			A

Minor Lane/Major Mvmt	EBL	EBT	WBT	WBR	SBLn1
Capacity (veh/h)	1470	-	-	-	915
HCM Lane V/C Ratio	0.022	-	-	-	0.023
HCM Control Delay (s)	7.5	-	-	-	9
HCM Lane LOS	A	-	-	-	A
HCM 95th %tile Q(veh)	0.1	-	-	-	0.1